

ASSEMBLY INSTRUCTION

Model : CF 1102 (6')

A	Headboard	1 pc
B	Side Wing (L/R)	1 pc
C	JCBC M6 X 50mm	4 pcs
D	M6 Flat Washer	4 pcs
E	M6 Spring Washer	4 pcs
F	M4 x 65mm	1 pc

Step 1 : Tighten the side wing (B) to headboard (A) as shown.

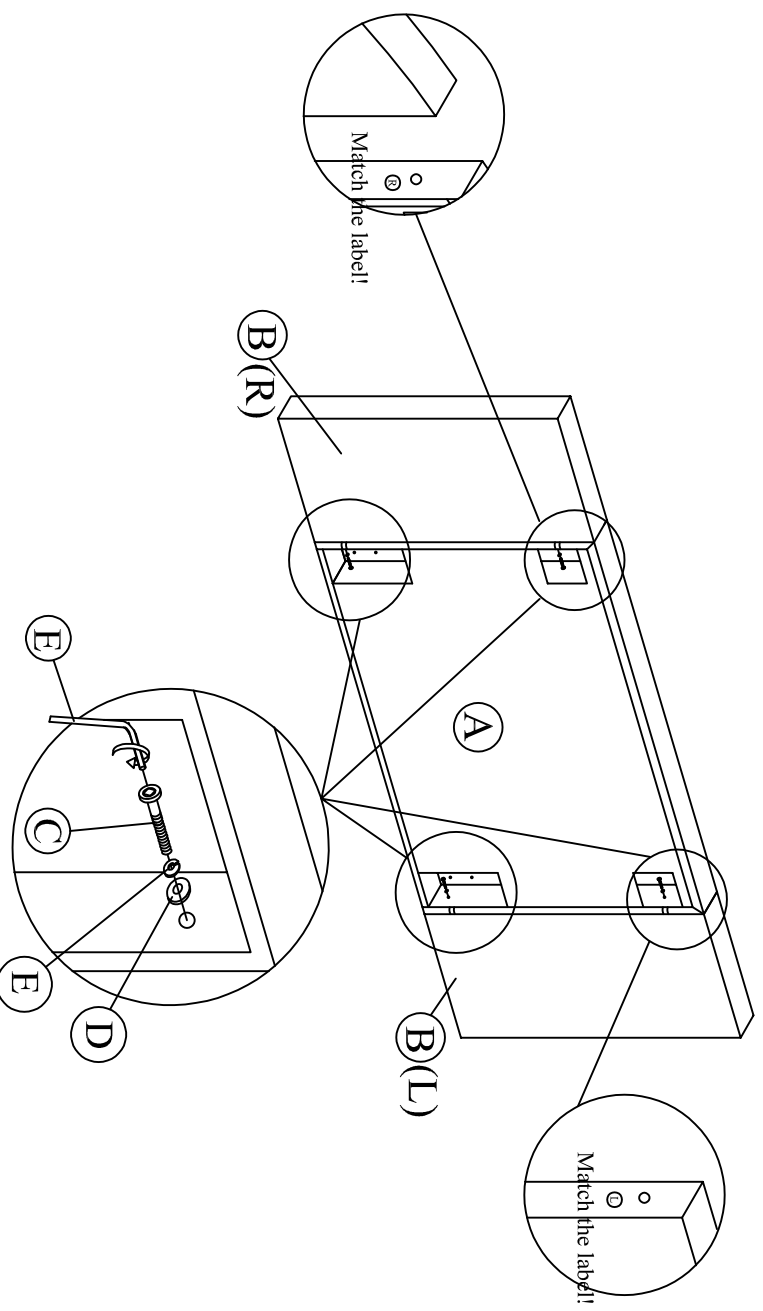

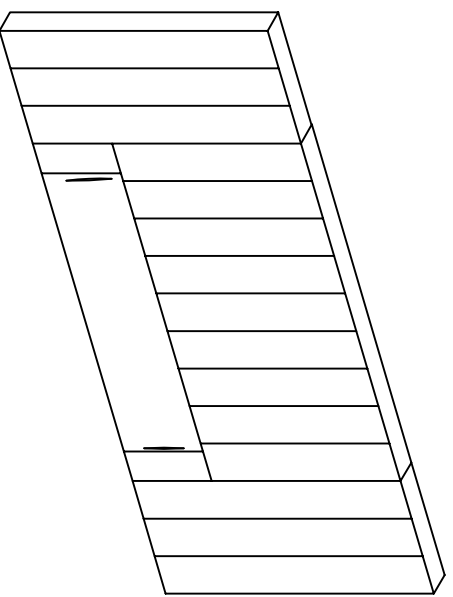

Step 2 : Assembly Complete.

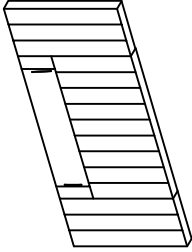
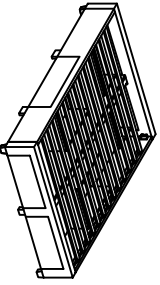
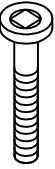

OPTION : HEADBOARD ATTACHED WITH BED BASE

Model : CF 1102 HEADBOARD , BASE

A	 Headboard	1 pc
B	 Bed Base	1 pc
C	 JCBC M6 X 50mm	4 pcs
D	 Flat Washer	4 pcs
E	 M4 x 65mm	1 pc

