

ITEM NO.NSJY0539

NOTE:

This brochure contains IMPORTANT safety info. Please read and keep for future reference.

MAINTAINANCE AND WARNING

- 1.Keep furniture away from heat sources.
- 2.Do not clean furniture with harsh cleaner or polishes.Do not use detergents,solvents,abrasives,spray packs or leather cleaner. Use non-color mild soa with warm water to clean spills(Mix 1:10 soap to water).
- 3.Do not place furniture under direct sunlight,material will possibly fade over time.
- 4.Do not use on site dry cleaning machine.Children should not climb or jump on the furniture.
- 5.Do not write on furniture that is not protectedby a padded barrier.
- 6.Not for commercial use,only for residential use.



Weight Limitation

LB 80 LBS

EXPLOSIVE VIEW

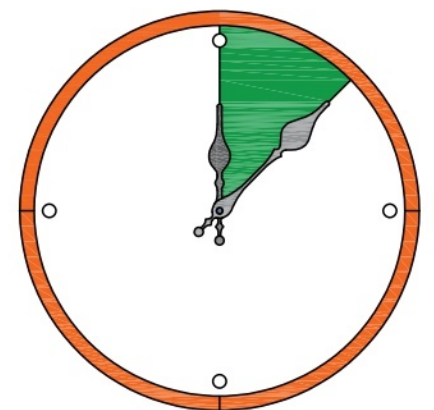
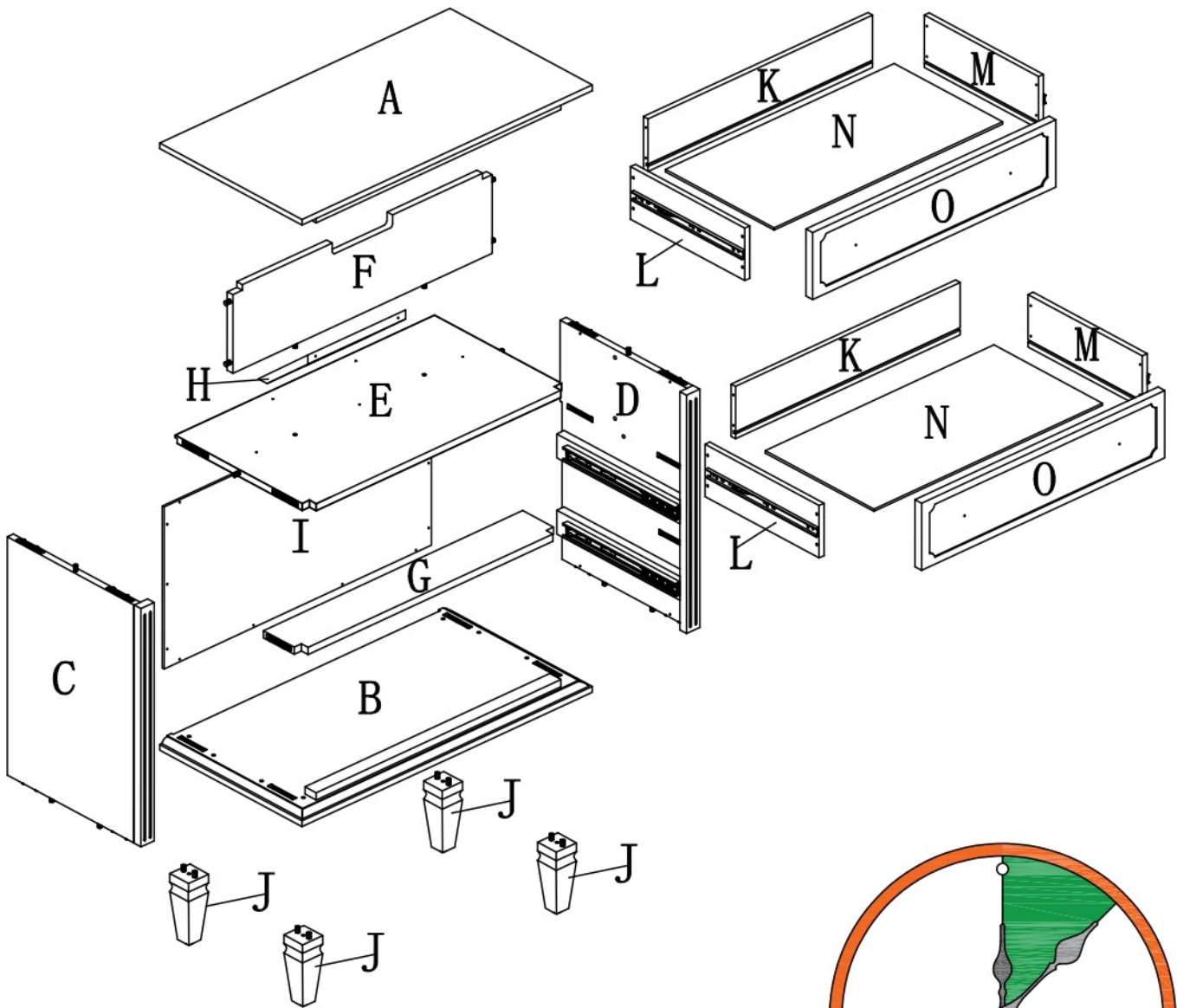





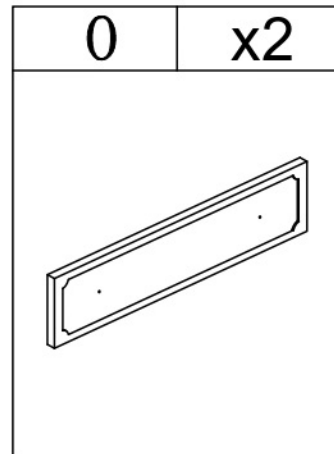
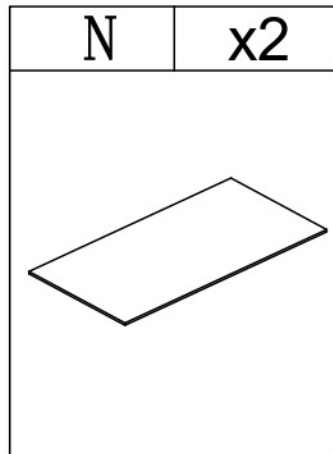
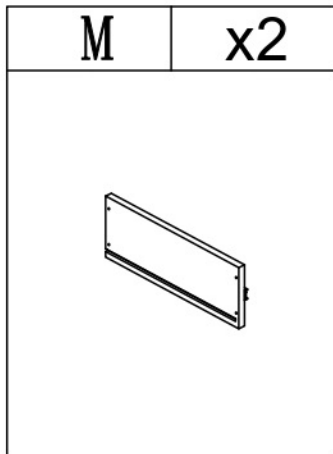
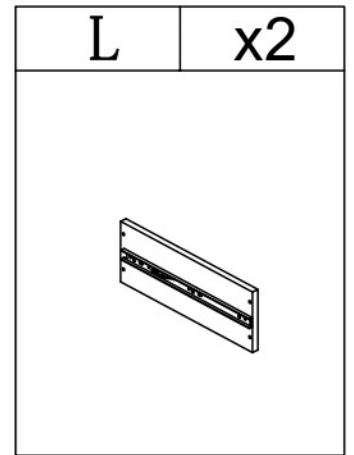
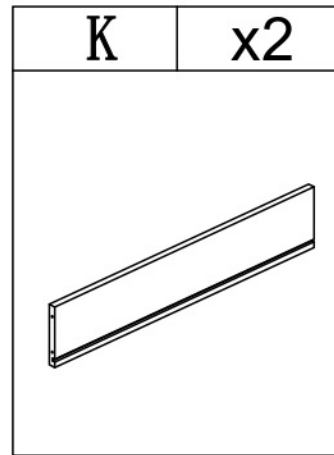
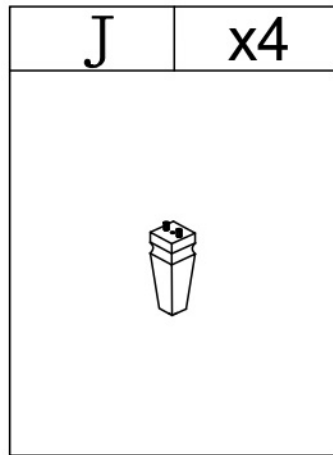
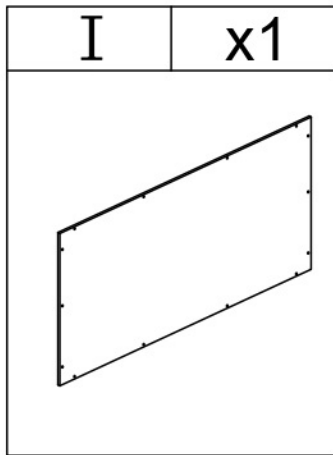
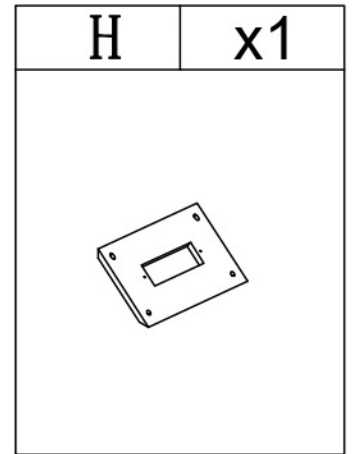
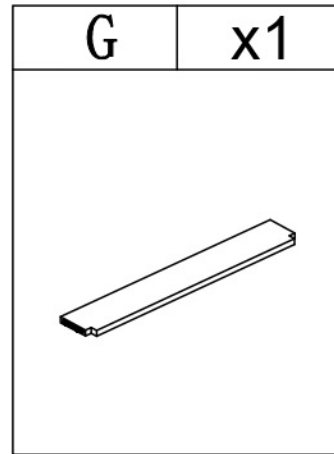
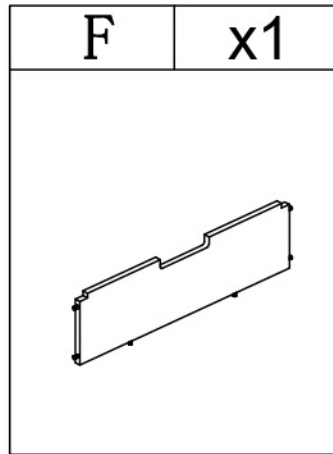
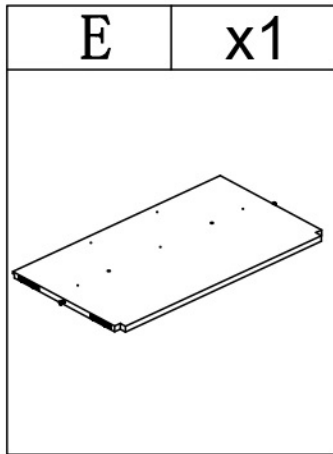
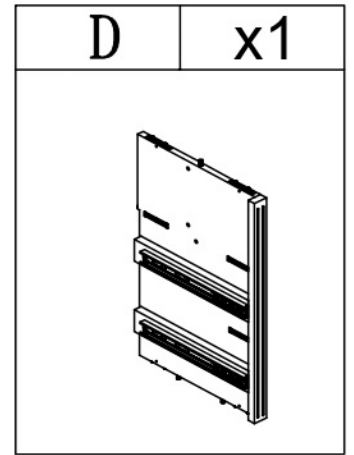
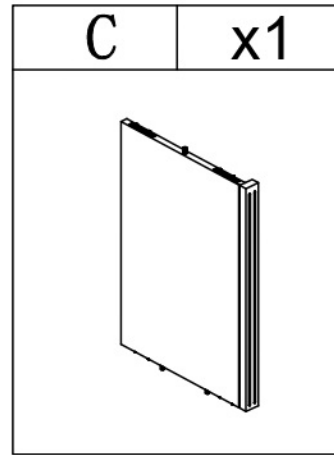
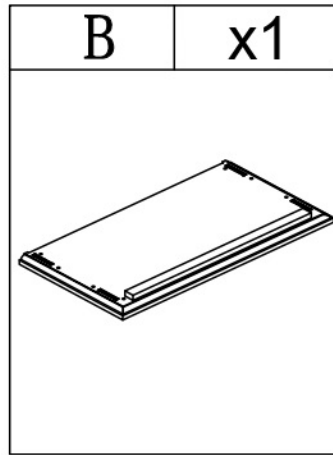
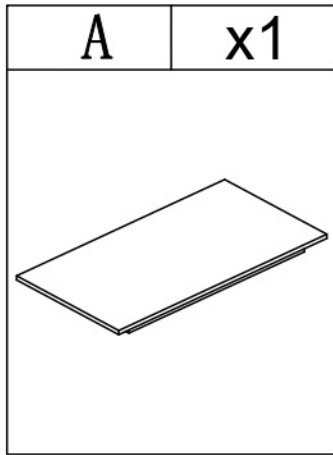



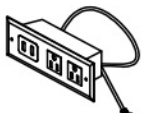

Around 40 min

PARTS LIST 1



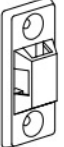

HARDWARE LIST

#1	x4	#2	x2	#3	x4	#4	x23	#5	x1	#6	x14
											
Ø4*22MM		Ø3*12MM				Ø4*25MM				Ø3*15MM	
#7	x4	#8	x2	#10	x1	#11	x2	#12	x2	#15	x2
											
Ø6*40MM						Ø4*39MM		Ø3*20MM			

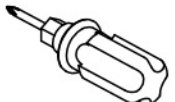
TOOL LIST

#13	x1	#14	x1
			
M6			

HARDWARE SPARE LIST



#7	x1	#4	x2	#6	x1
					
Ø6*40MM		Ø4*25MM		Ø3*15MM	

ASSEMBLY INSTRUCTIONS

STEP-1

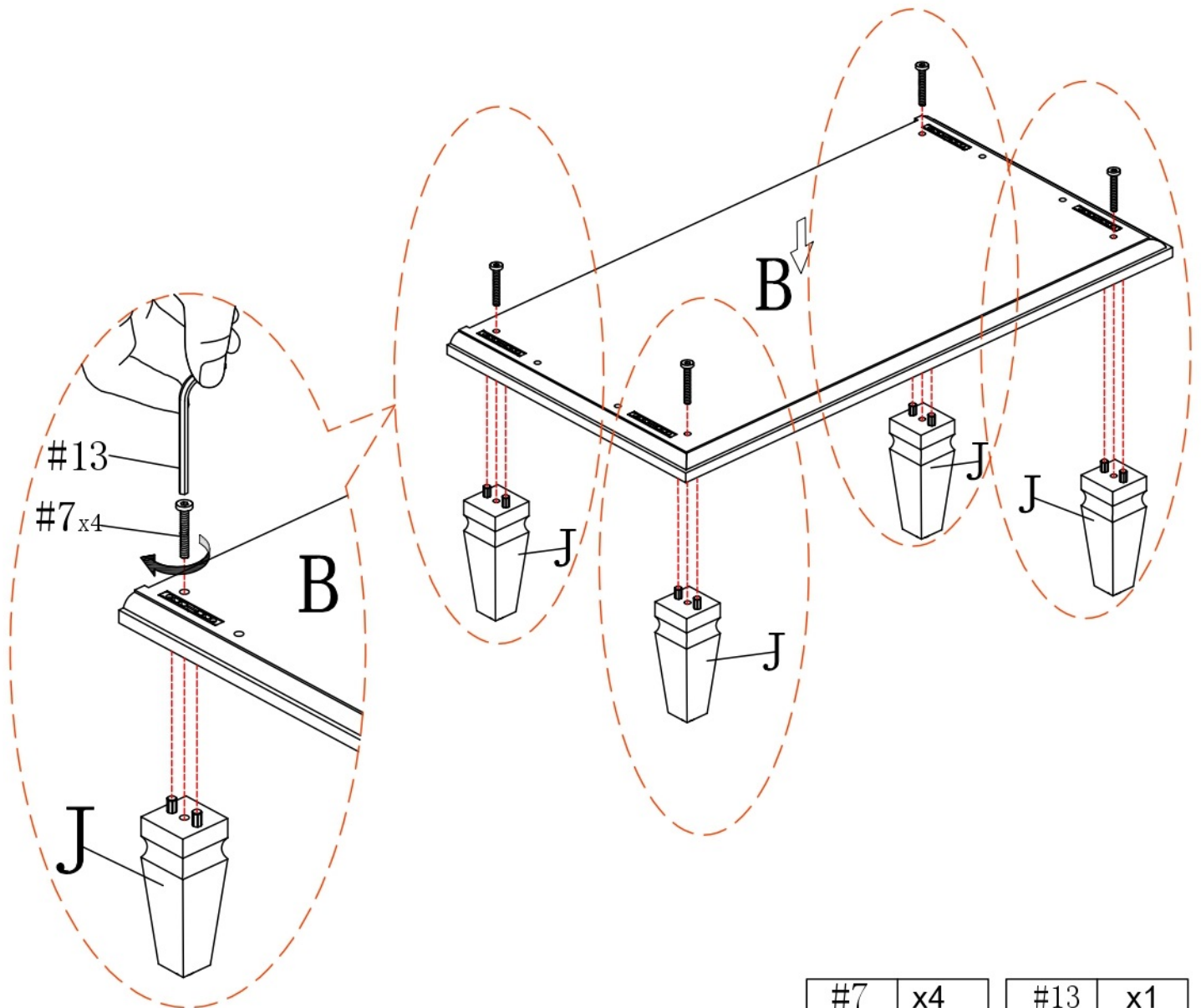
1. install leg (J) on of bottom panel B, ensure the corresponding holes are aligned and fix with bolt #7, then tighten the bolt with an Allen key #13.



#7	x4	#13	x1
			
Ø6*40MM		M6	

ASSEMBLY INSTRUCTIONS

STEP-2

1. Insert part (F) into part (E), make sure all holes aligned and fix with screw #4 then tighten the screw with screwdriver #14.

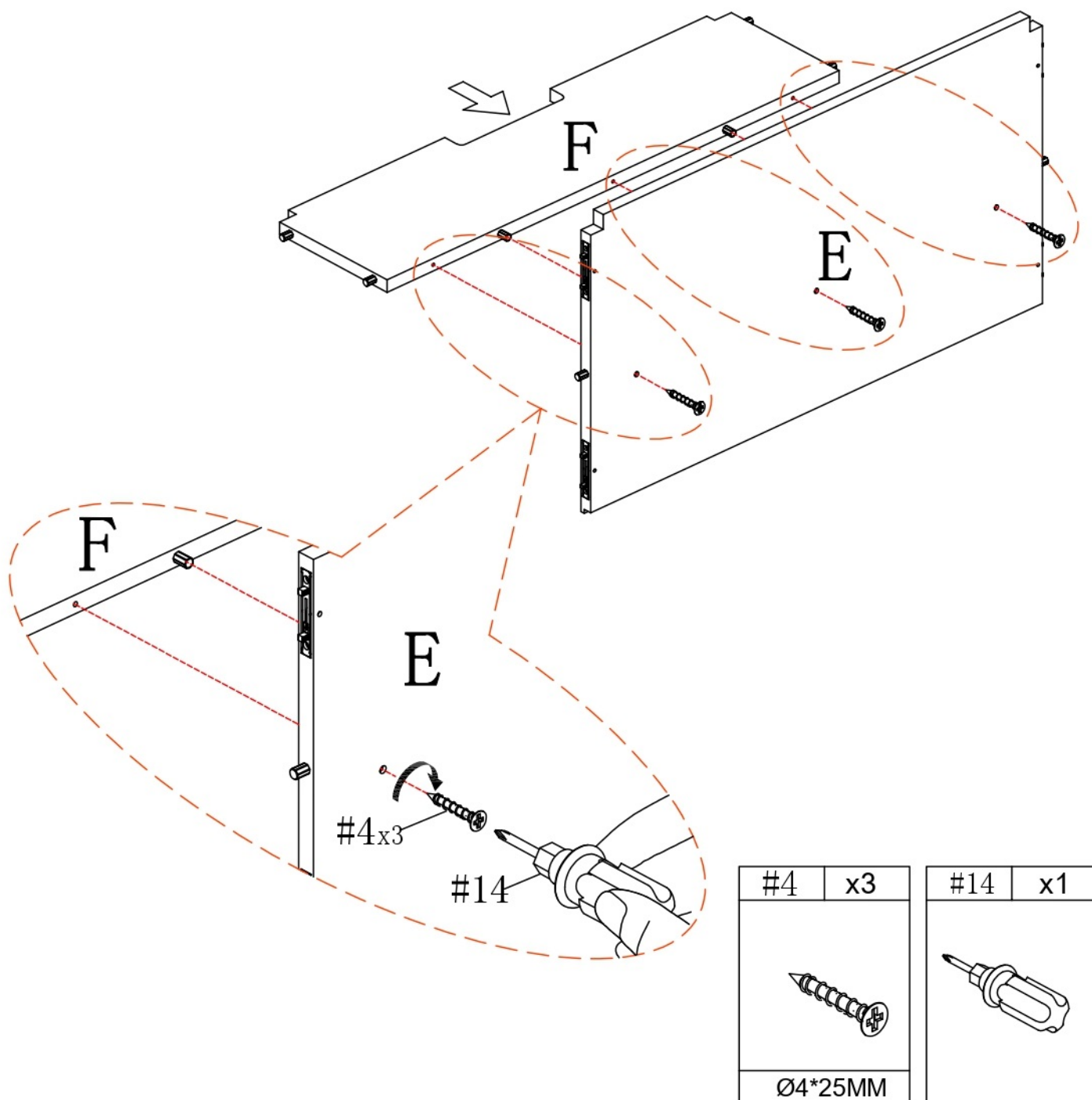

ASSEMBLY INSTRUCTIONS

STEP-3

1. Insert panel (E/F/G) into panel (C/D), make sure all holes aligned and then tighten it with allen key #13 as picture show.

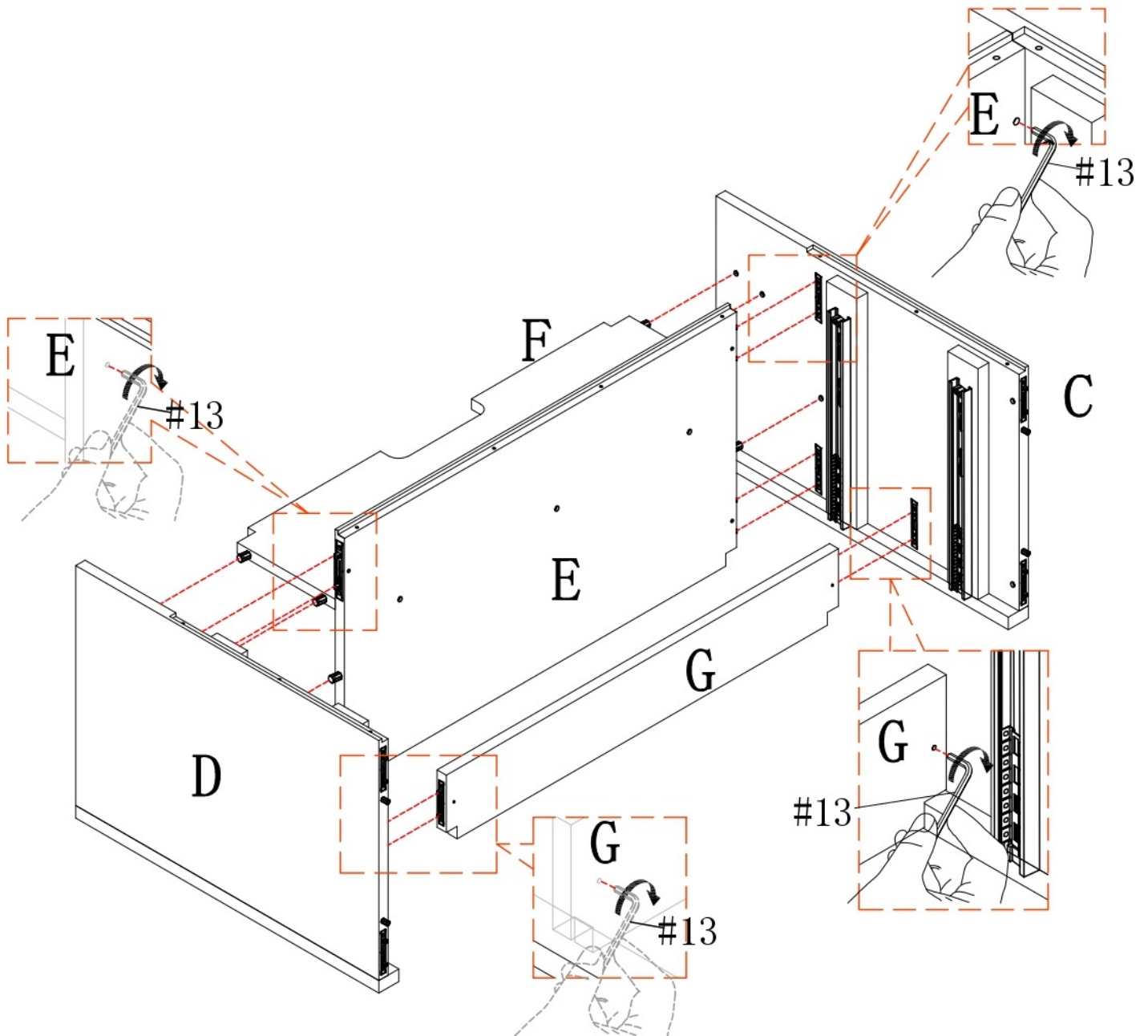

#13	x1
	
M6	

ASSEMBLY INSTRUCTIONS

STEP-4

1. Insert preassembled step 4 into the corresponding hole of bottom panel (B), make sure all holes aligned and use allen key #13 to tighten it as picture show.

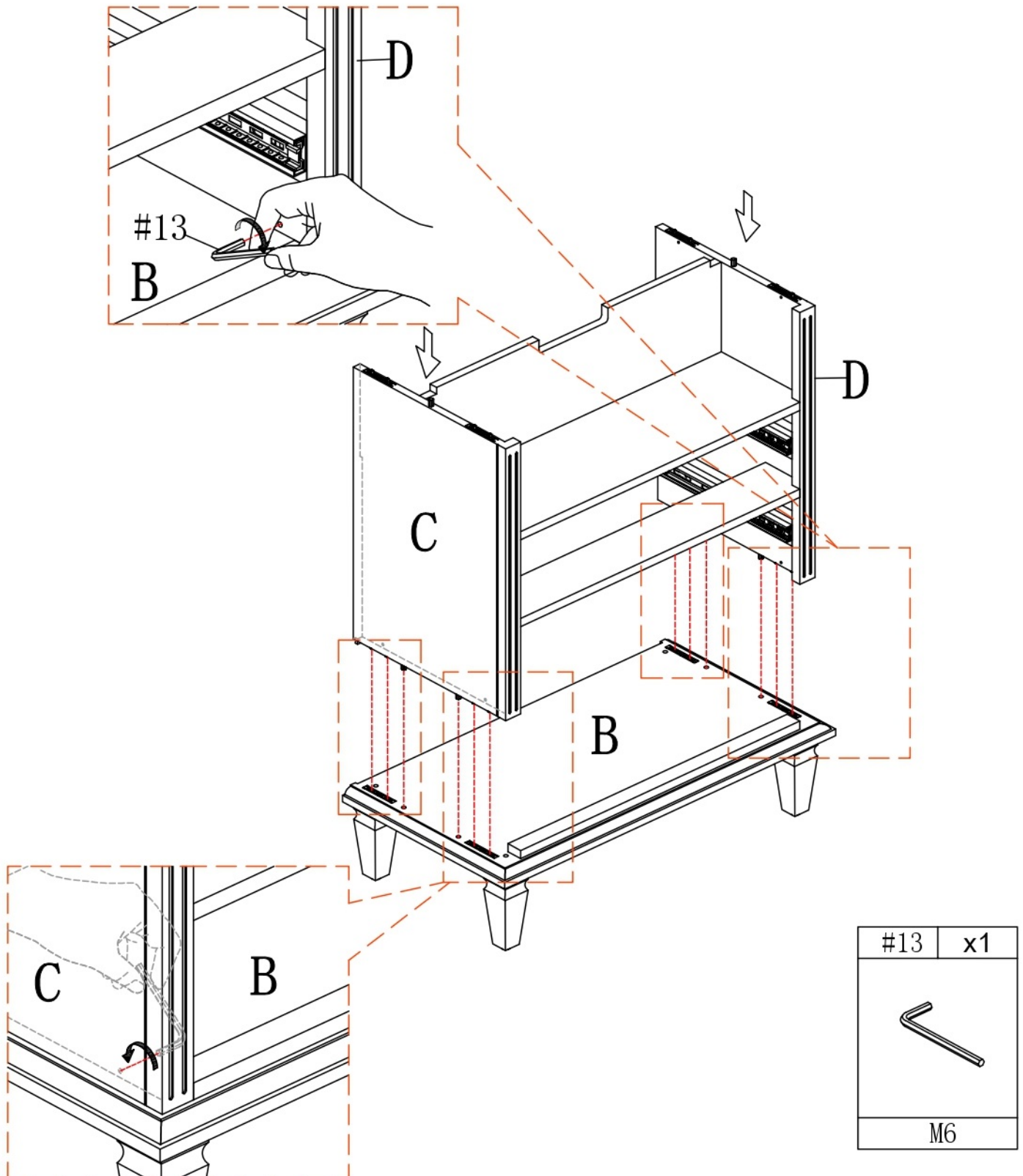

ASSEMBLY INSTRUCTIONS

STEP-5

1.insert back panel(I) into the groove of preassembled step 4 ,make sure all holes aligned and use screw#6 to attach them , tighten screw #6 with screwdriver#14.

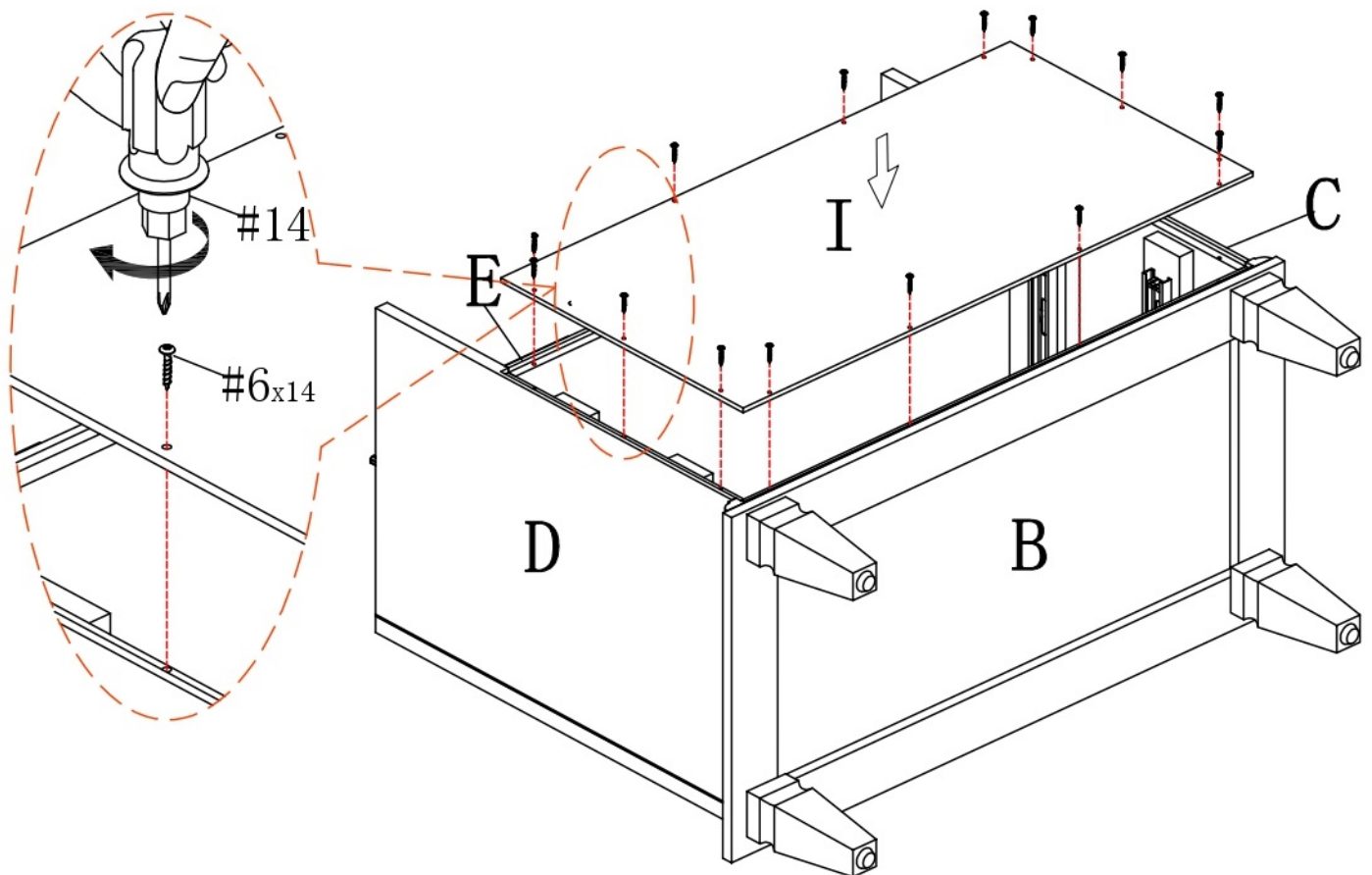

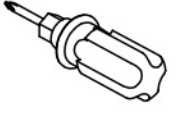

#6	x14	#14	x1
			
Ø3*15MM			

ASSEMBLY INSTRUCTIONS

STEP-6

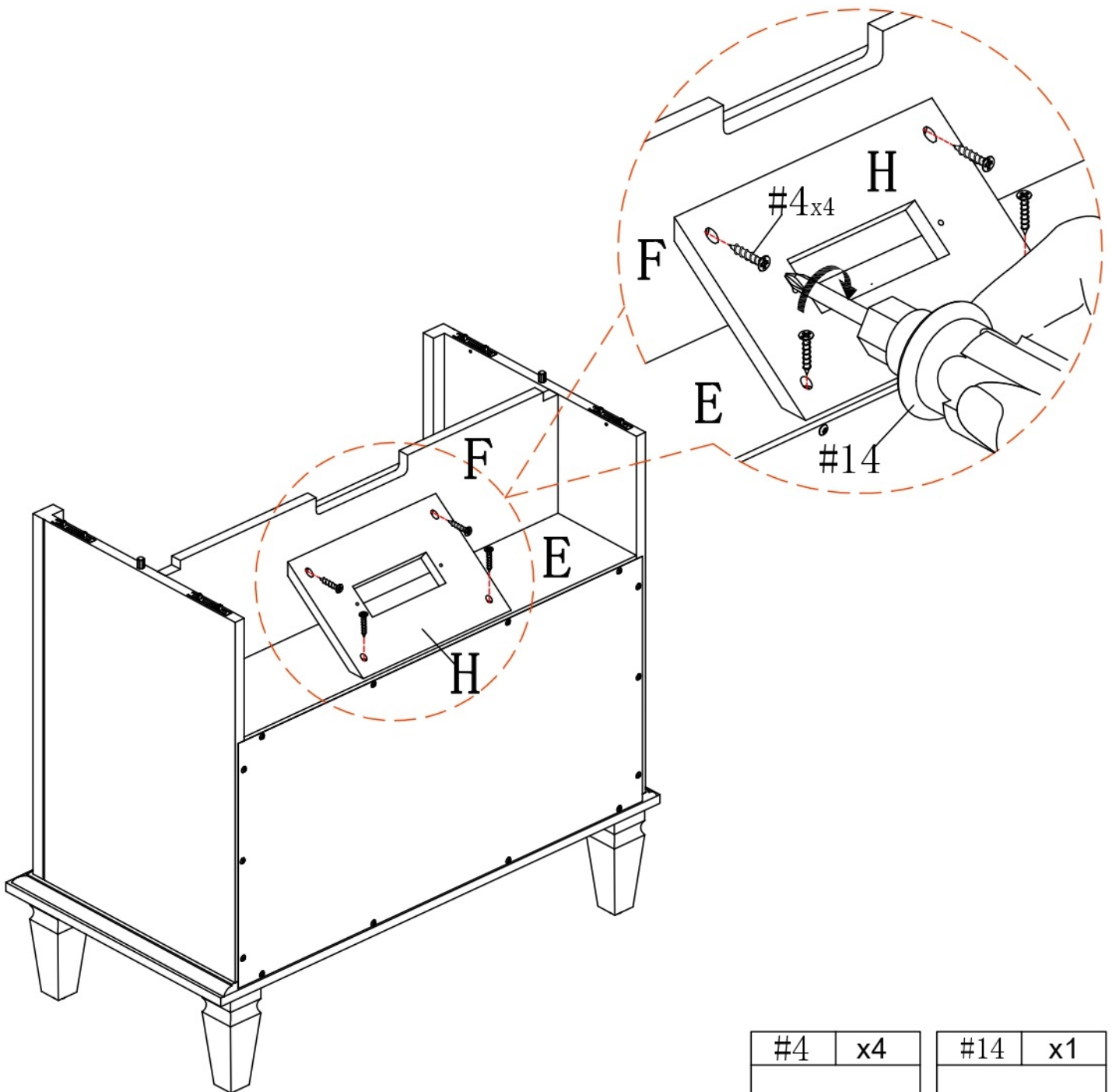
1.insert part (H) into the preassembled step 5,make sure all holes aligned and use screw#4 to attach them , tighten screw #4 with screwdriver#14.

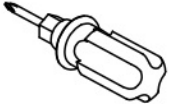

#4	x4	#14	x1
			
Ø4*25MM			

ASSEMBLY INSTRUCTIONS

STEP-7

1.insert part #5 into the preassembled step 6,make sure all holes aligned and use screw #2 to attach them , tighten screw #2with screwdriver#14.

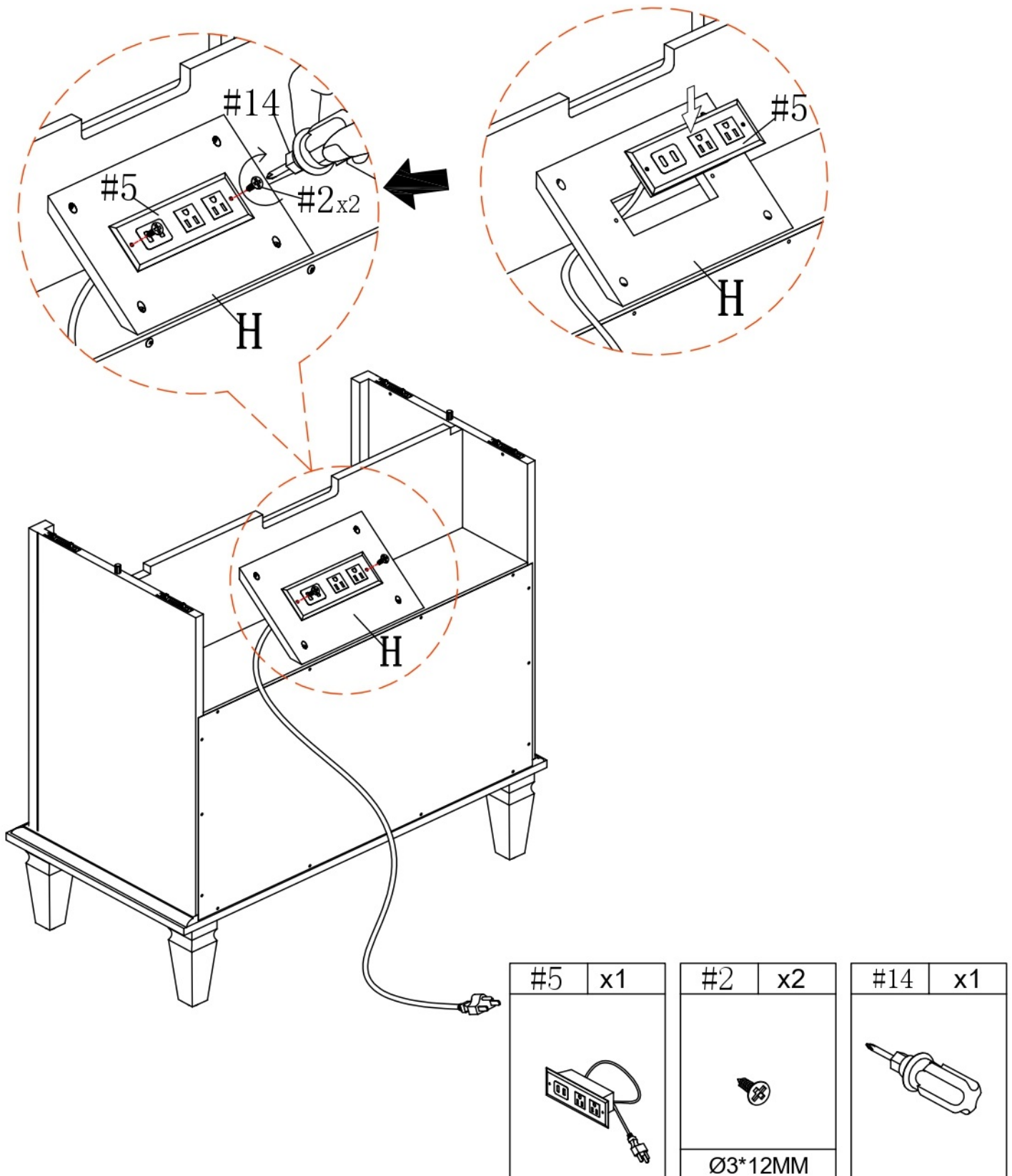

ASSEMBLY INSTRUCTIONS

STEP-8

1. Insert the top panel (A) into the corresponding holes in the pre-assembly step 7, make sure all the holes line up and tighten it with #13 Allen key as shown in the picture.

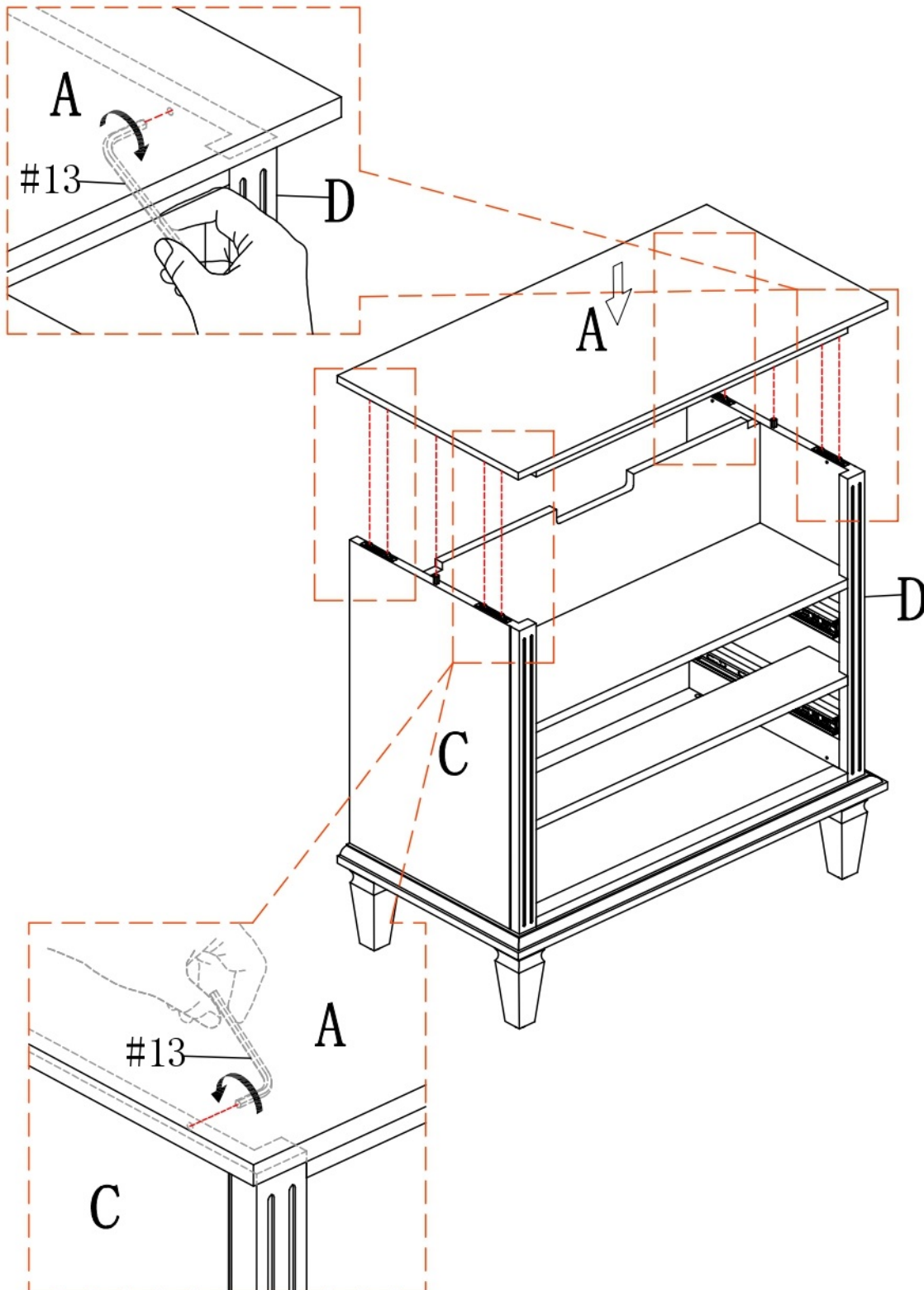

#13	x1
	
M6	

ASSEMBLY INSTRUCTIONS

STEP-9

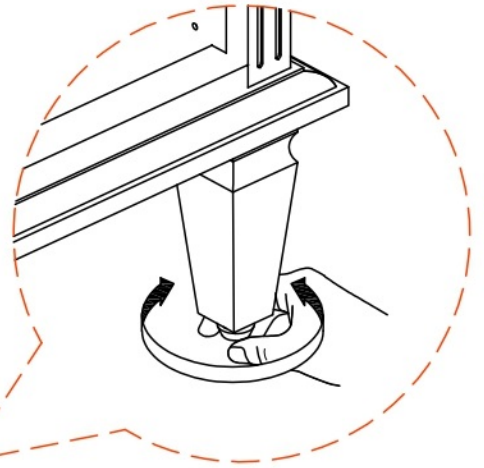
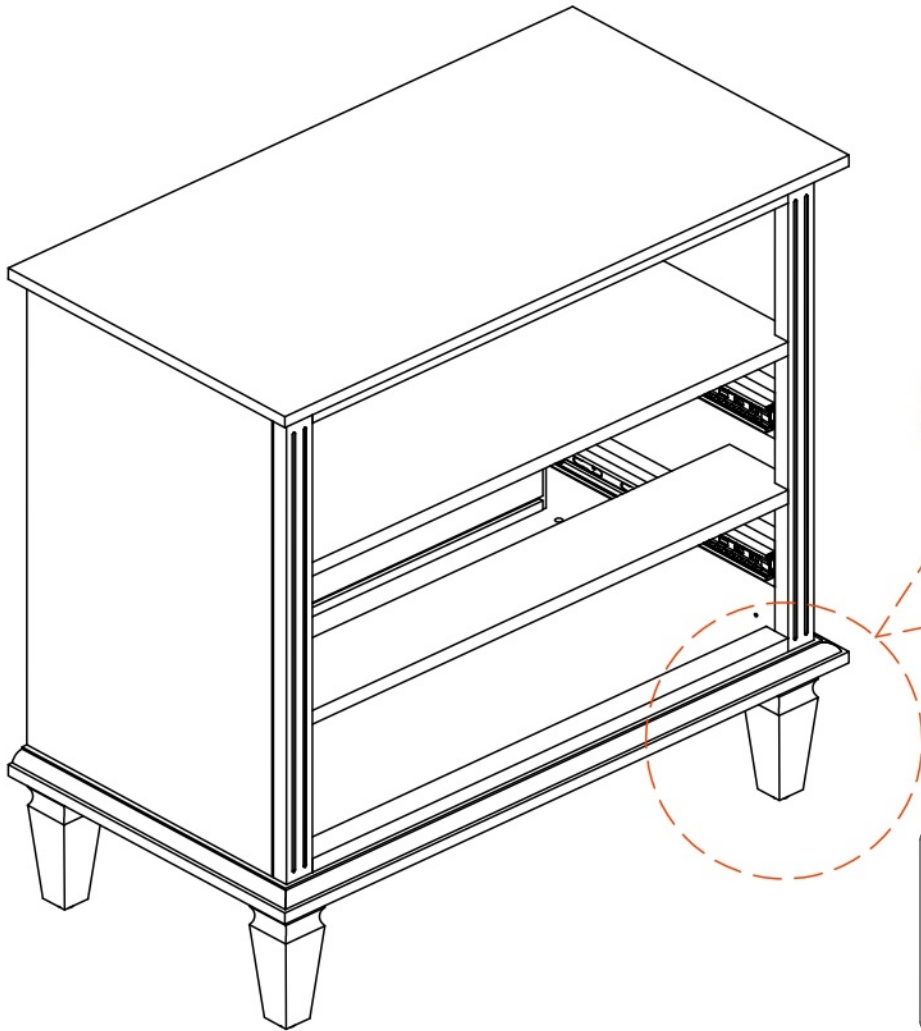

Attention:
Before the next step, adjust the feet of the locker to keep it level.

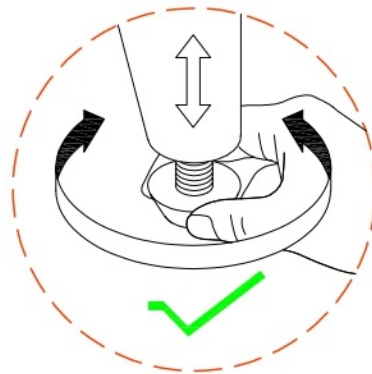
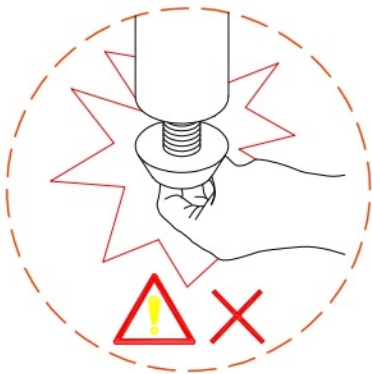

ASSEMBLY INSTRUCTIONS

STEP-10

1. Connect part (L&M) to part (O) using screw #4 and tighten it with screwdriver #14.

2. slide in the part (N) into the groove in part (L&M). make sure they are also in groove in part (O).

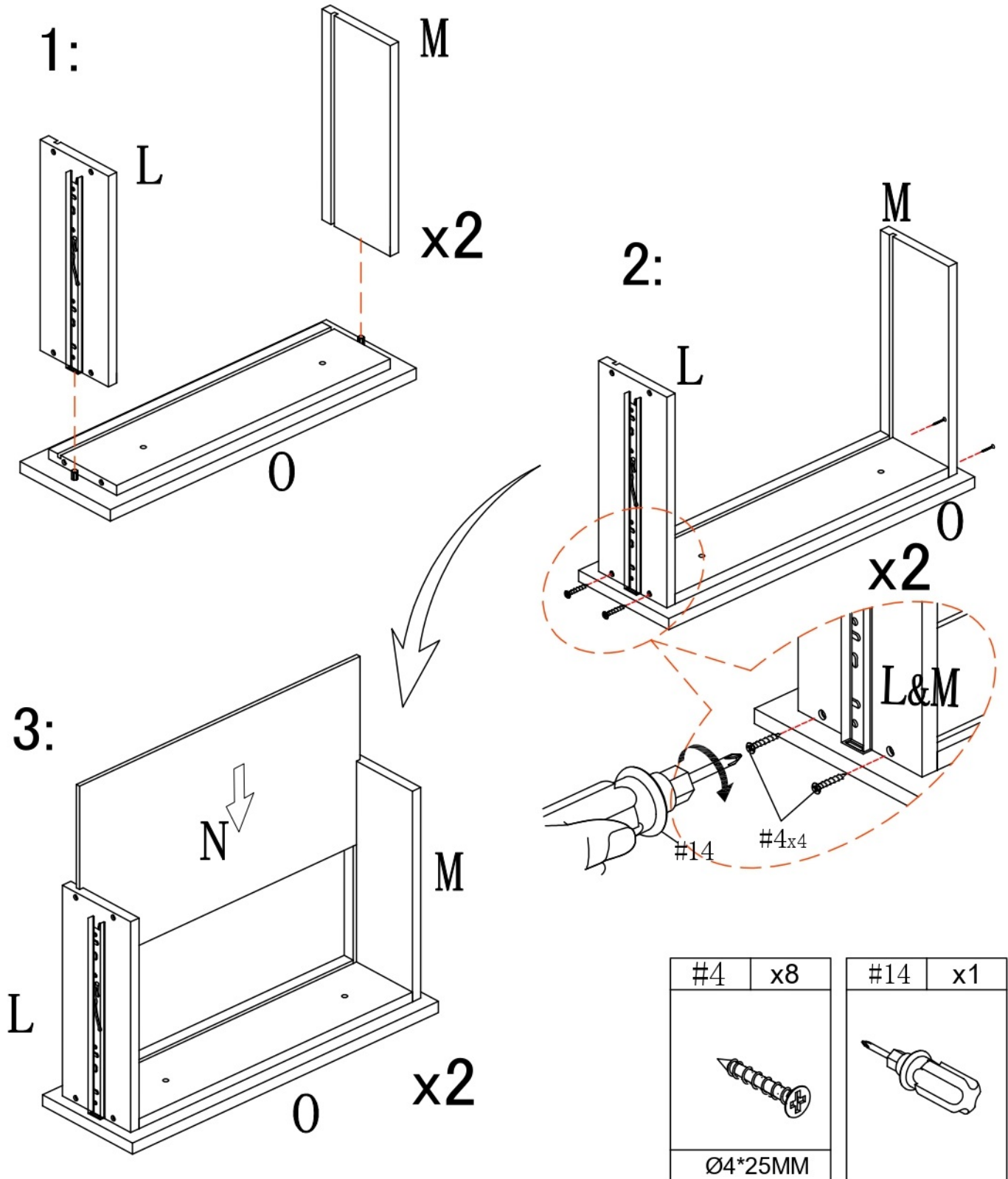

ASSEMBLY INSTRUCTIONS

STEP-11

1. Connect the (O) and (L&M) using screw #4 , and tighten it with screwdriver #14.
2. Install handle #3 to panel (O) using bolt #1 and tighten it with screwdriver #14.

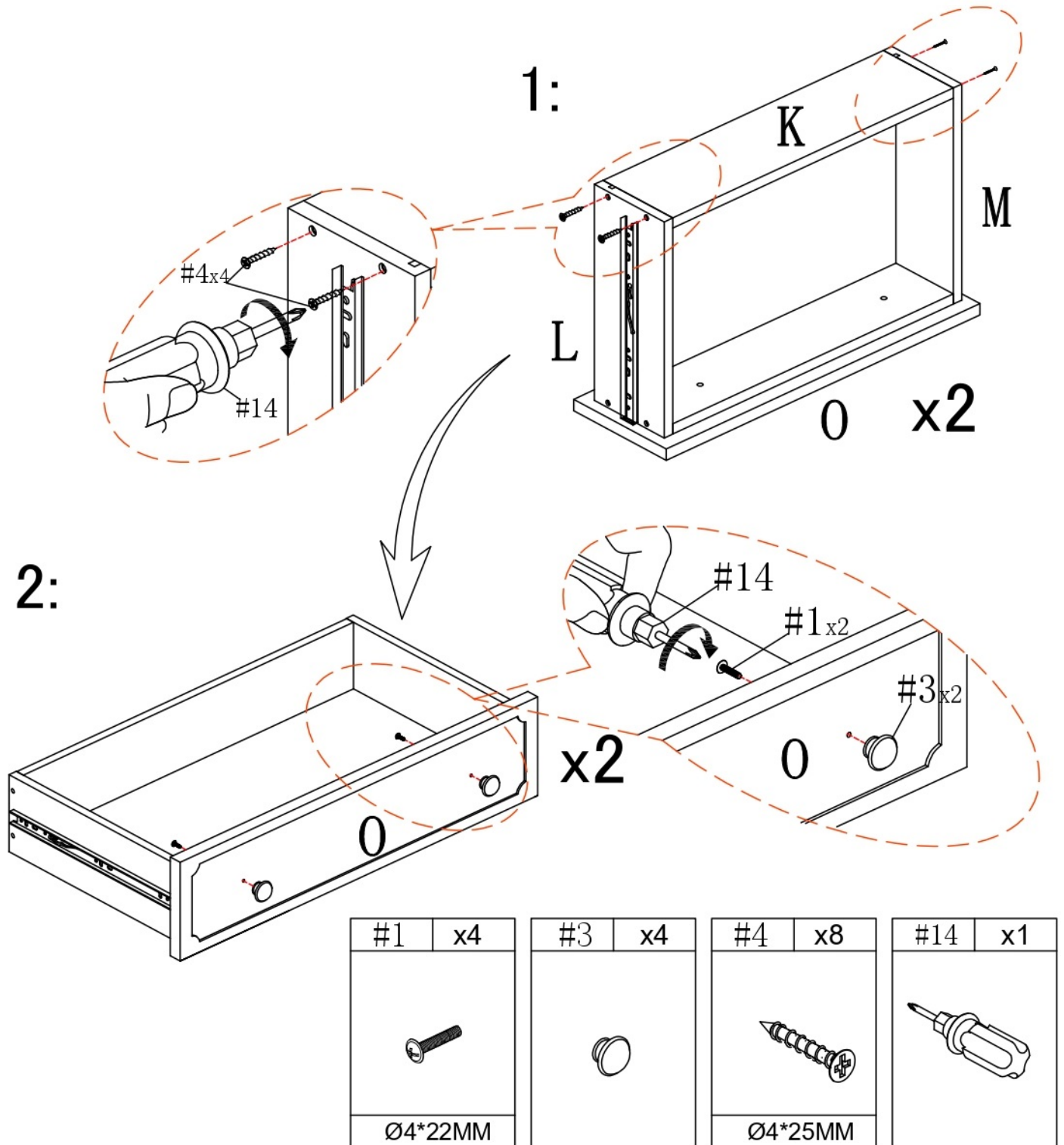

ASSEMBLY INSTRUCTIONS

STEP-12



Attention: When installing the drawer, slide the steel ball slide rail of side panel to the most front as picture show.

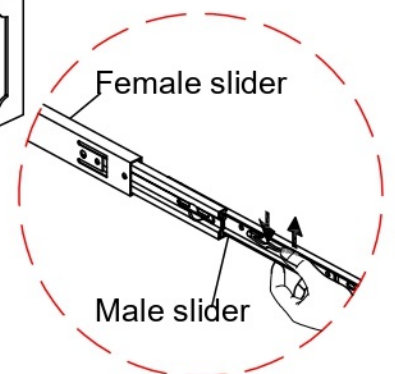
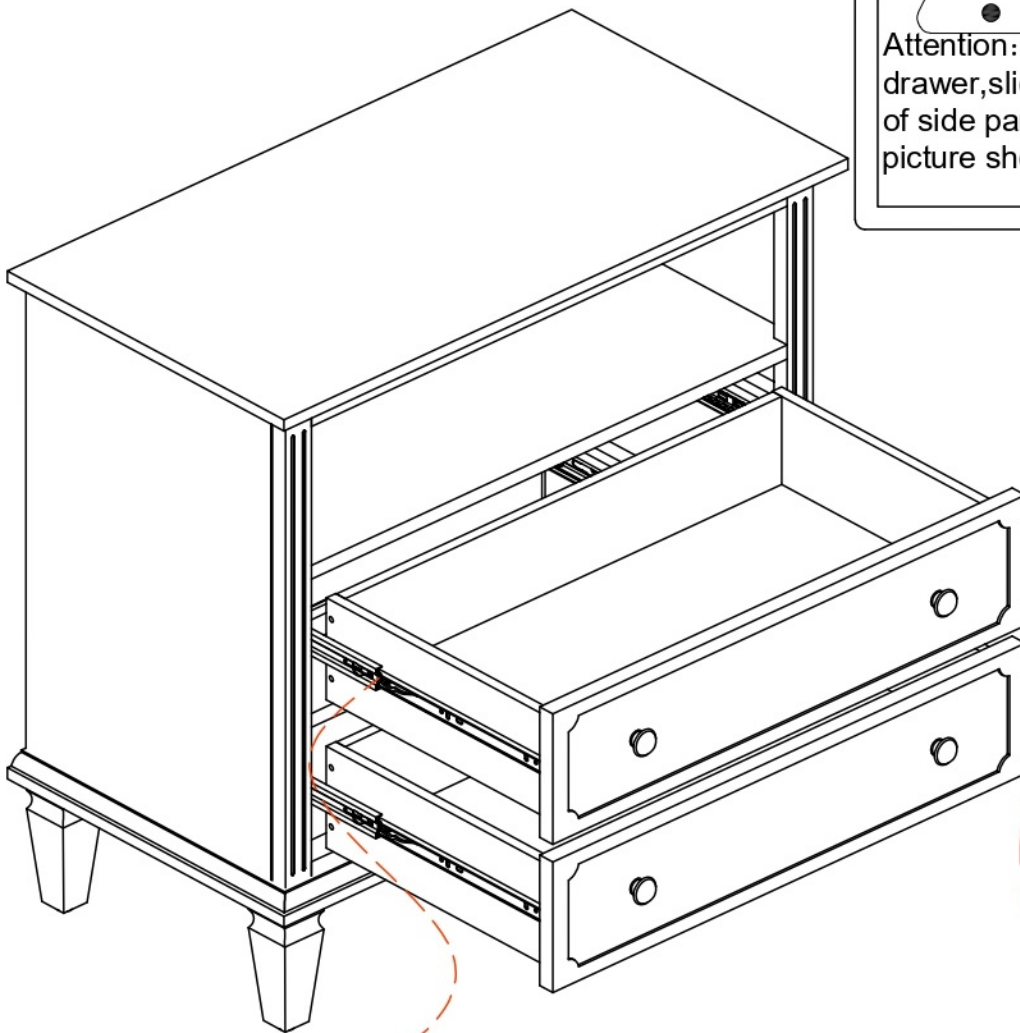

Schematic diagram of slide rail disassembly

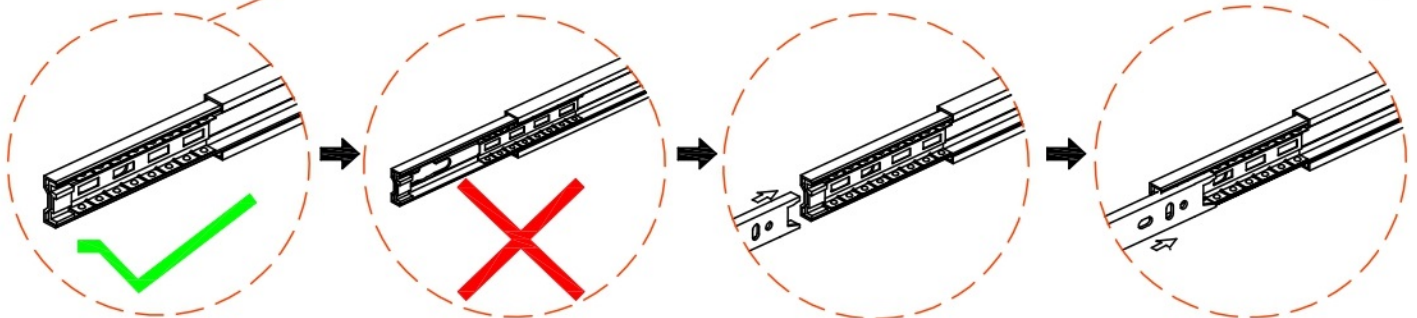



ASSEMBLY INSTRUCTIONS

STEP-13

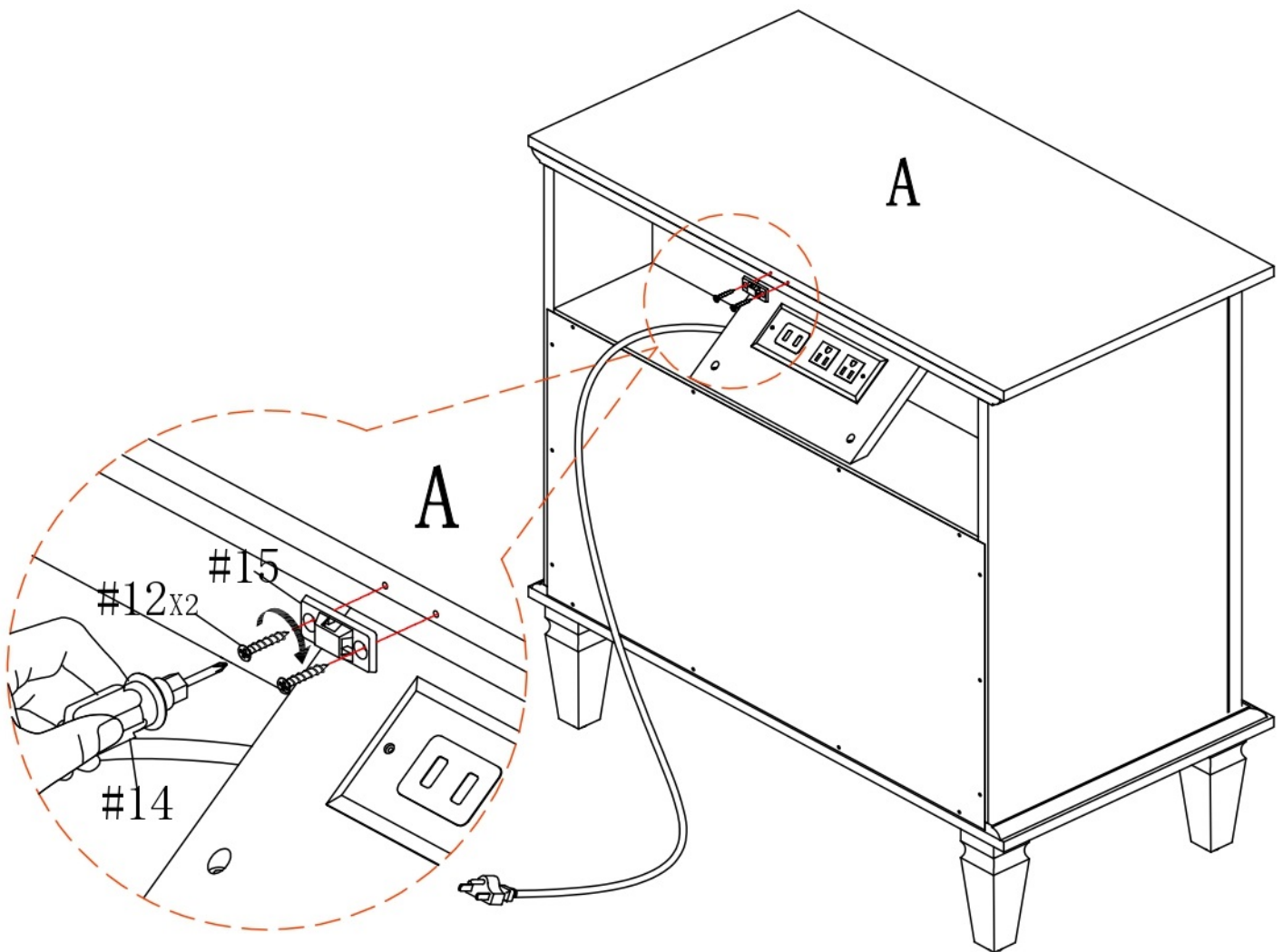

Use screw #12 to attach plastic bracket #15 to panel (A), make sure all holes aligned and tighten screw #12 with screwdriver #14

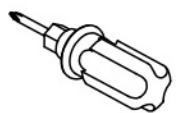

#15	x1	#12	x2	#14	x1
					
		Ø3*20MM			

ASSEMBLY INSTRUCTIONS

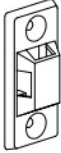
STEP-14

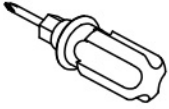
#15	x1	#8	x2	#11	x2	#14	x1
				 Ø4*39MM			

1. Mark the position on the wall, that corresponds to the location of bracket #15 on the panel (A); Drill and insert the expandable screw #8 by hammer.
2. Assemble the bracket #15 to the wall. Align the hole in the bracket #15 with the expandable screw #8, use screw #11 to attach it, tighten screw #11 with screwdriver #14.

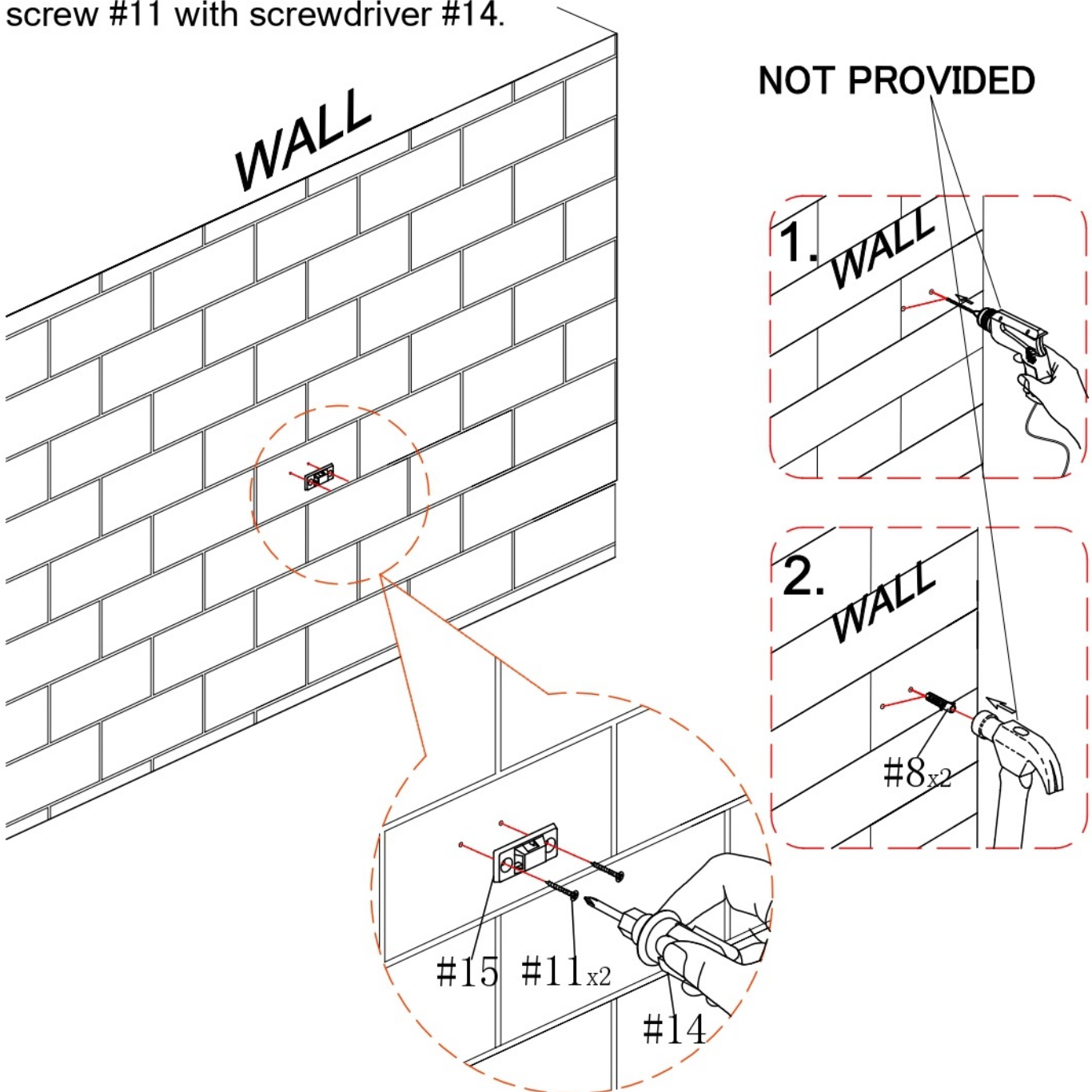

ASSEMBLY INSTRUCTIONS

STEP-15

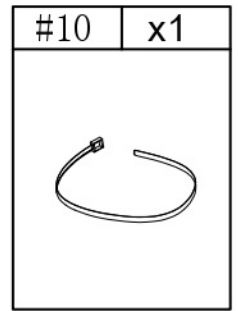

3. Let the plastic belt #10 pass through bracket #9 and pull tightly.

