

Assembly Manual

Right Arm Seat

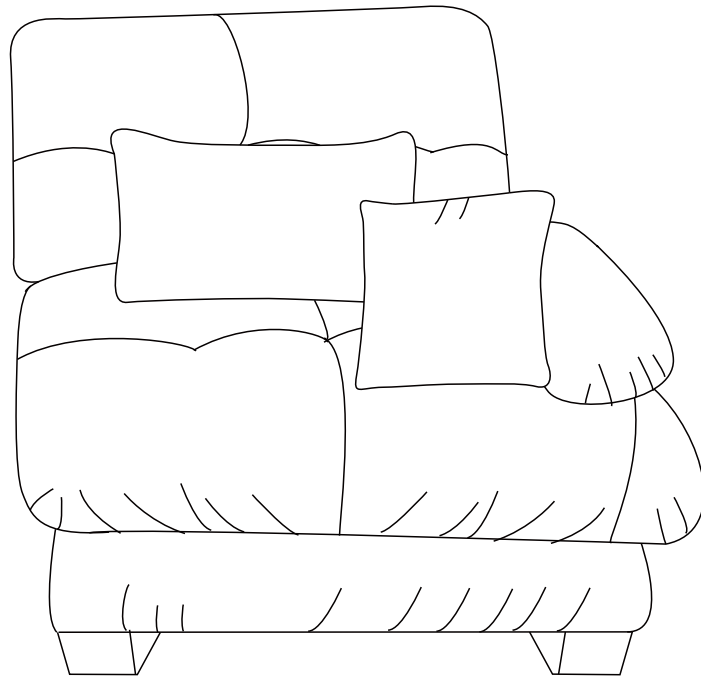







Components List-Right Arm Seat

Before Assembly

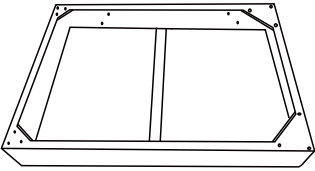
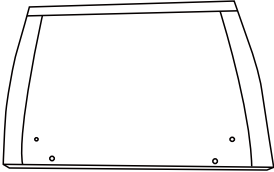
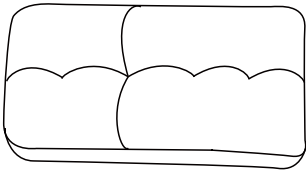
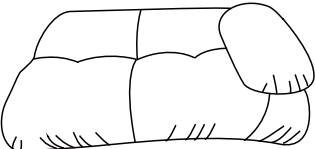
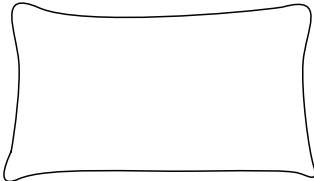
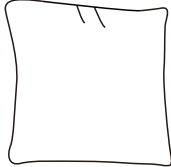
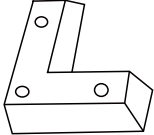
IMPORTANT NOTE:

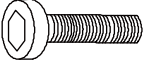
1. Make sure all parts and hardware are included and free of obvious defect before disposing of any packaging.
2. Place all wooden parts on a clean and smooth surface such as a rug or carpet to avoid the parts from being scratched.
3. Do not tighten all screws and bolts until completely assembled.
4. Assembly will require two people.

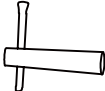
Part List

B  Right seat frame*1	C  Backrest*1	E  Right back cushion*1
G  Right seat cushion*1	H  Waist pillow*1	I  Pillow* 1
J  Leg*4	K  Bolt*4 M8*80mm	L  M6*50mm Bolt*12
M.  Washer*4	N  Allen key*1	O  Allen key*1

Assembly Instruction-Right Arm Seat

Step 1

Assemble the leg (J) to the right seat frame (B) with Bolts (L).

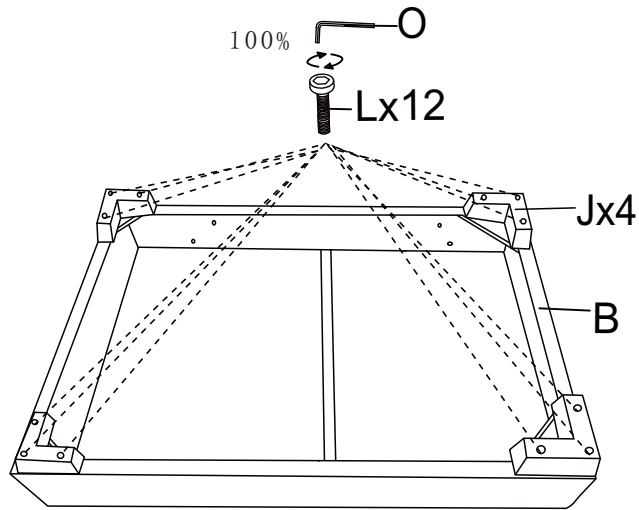

Step 2

Assemble the big backrest (C) with Bolts (K)

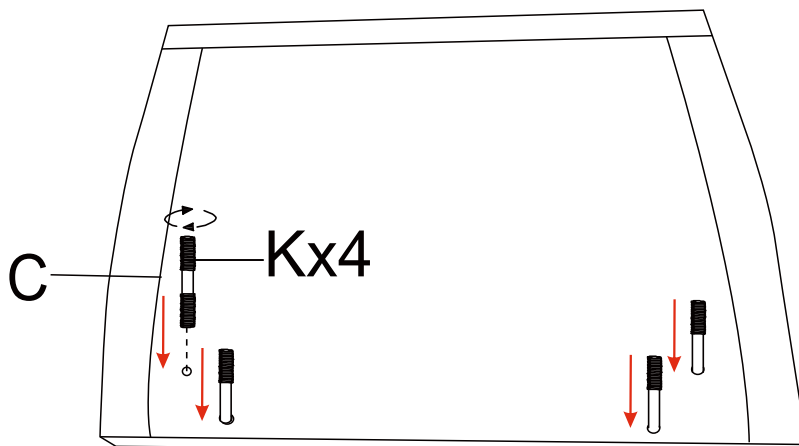

Step 3

Assemble the big backrest(C) to the right seat frame(B) with washer(M).

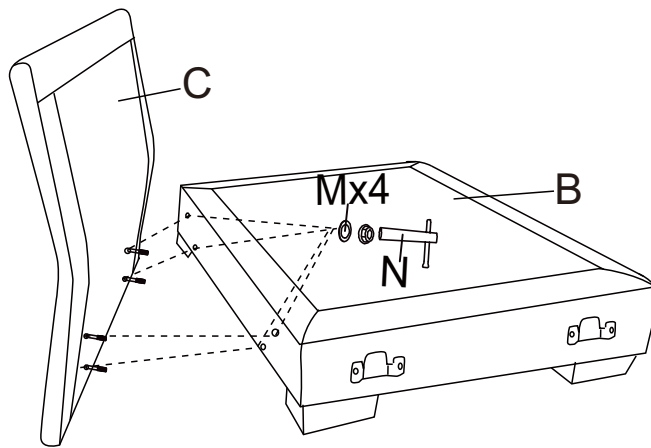

Step 4

Put right back cushion(E) and right seat cushion (G) to the sofa.

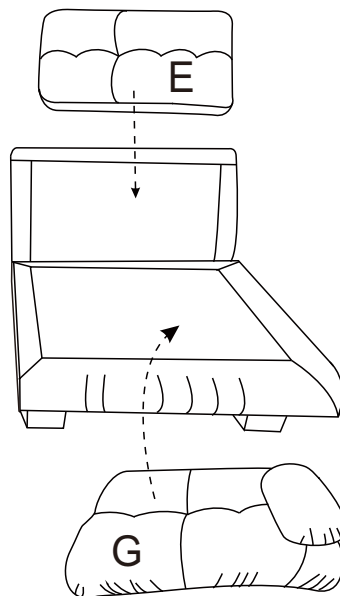

Assembly Instruction

Step 5

Put waist pillow(H) and pillow(I) to the sofa.

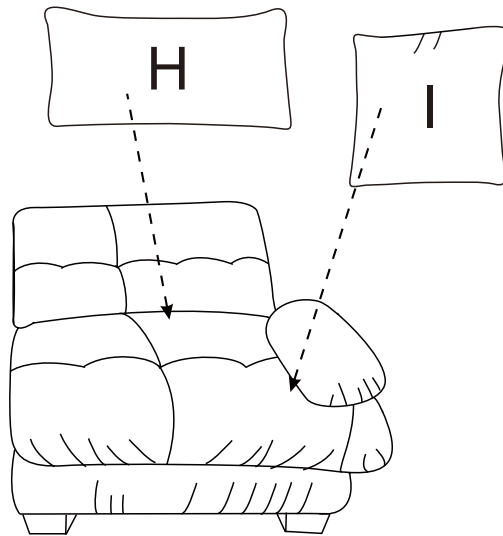

Step 6

Completed .

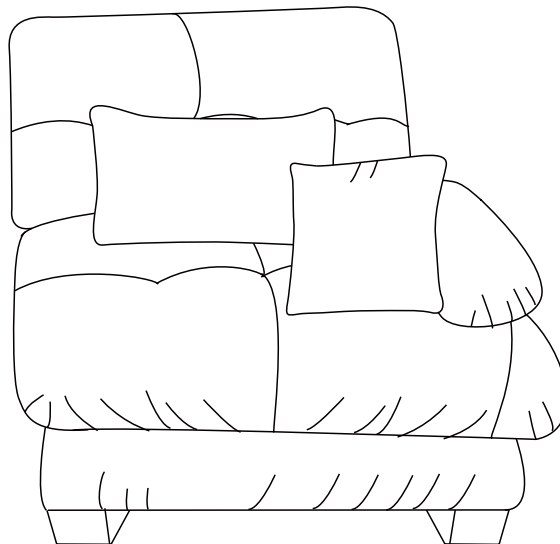

Please install according to the combination method purchased

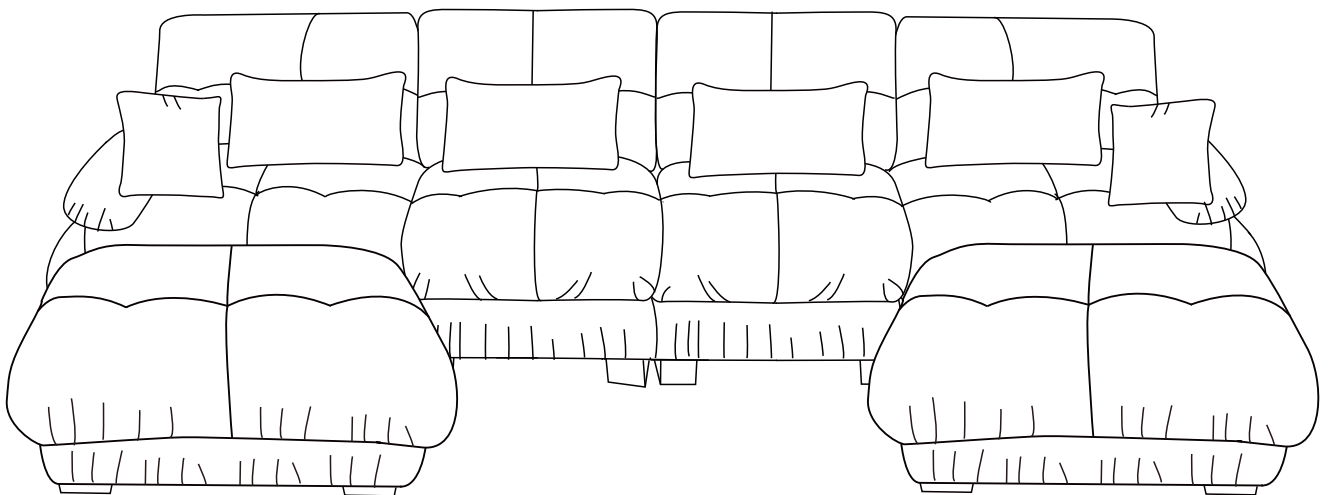
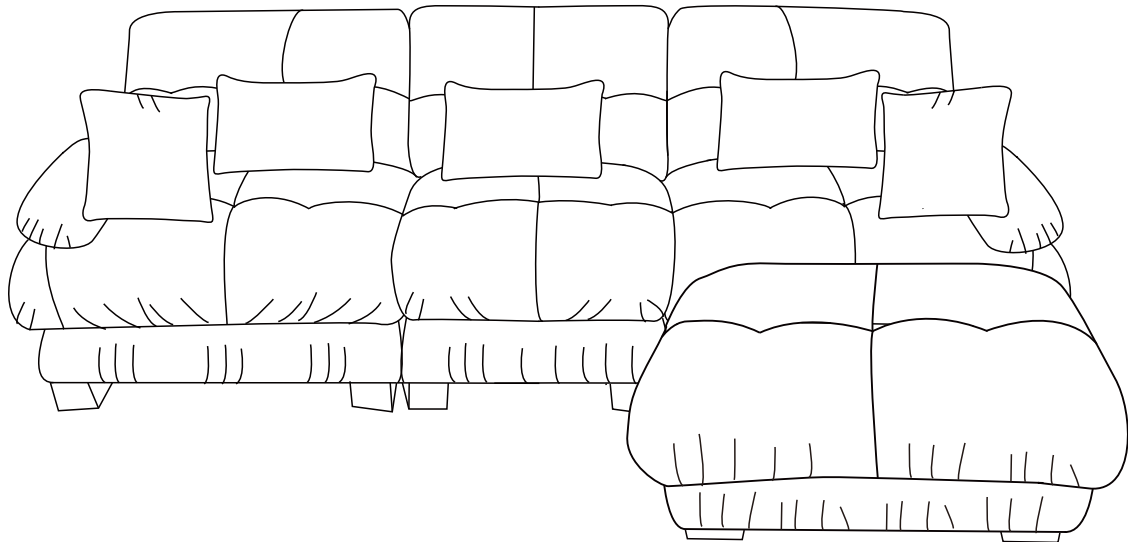

Note: Cushions are vacuum-packed & it may take approximately 72 hours to fully expand to their intended size & shape