

# Assembly Manual

## Right Arm Seat

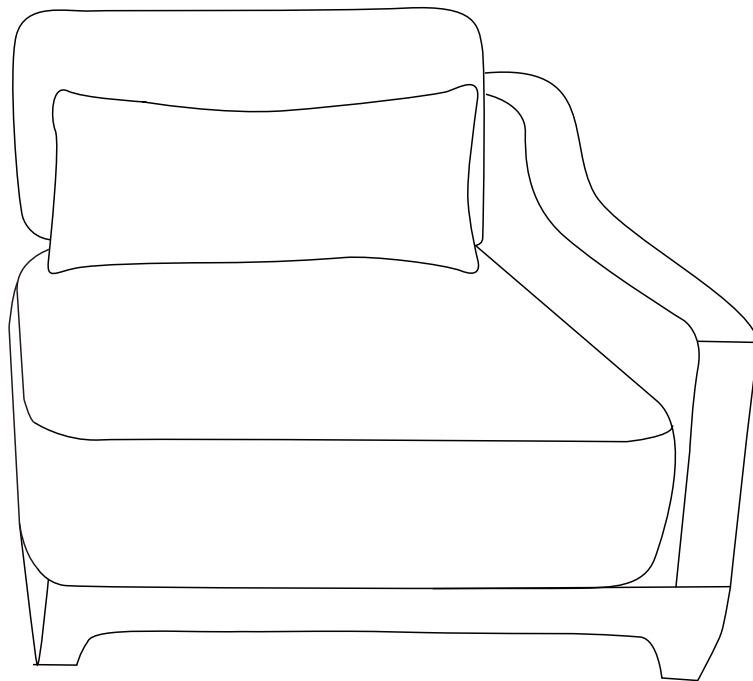

### **Customer Service Before Return:**

If part is missing or damaged, or you need help with assembly please do not hesitate to contact us.

### **SELLER CONTACT INFORMATION:**

[cpcontacts@163.com](mailto:cpcontacts@163.com)





# Components List-Right Arm Seat

## Before Assembly

### IMPORTANT NOTE:

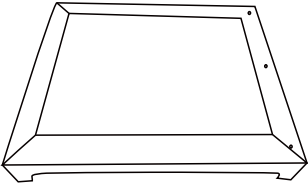
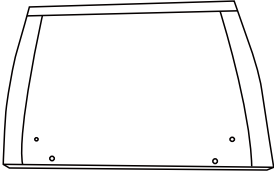
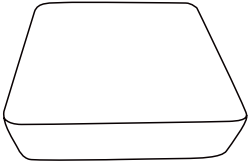
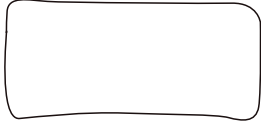
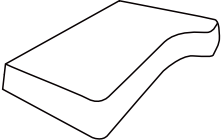
1. Make sure all parts and hardware are included and free of obvious defect before disposing of any packaging.
2. Place all wooden parts on a clean and smooth surface such as a rug or carpet to avoid the parts from being scratched.
3. Do not tighten all screws and bolts until completely assembled.
4. Assembly will require two people.

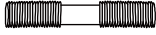
## Part List

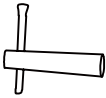
<p><b>B</b></p>  <p>Right seat frame*1</p>	<p><b>C</b></p>  <p>Backrest*1</p>	<p><b>D</b></p>  <p>Seat cushion*1</p>
<p><b>E</b></p>  <p>Back cushion*1</p>	<p><b>F</b></p>  <p>Arm*1</p>	<p><b>G</b></p>  <p>Pillow*1</p>
<p><b>H</b></p>  <p>Leg*4</p>	<p><b>I</b></p>  <p>Bolt*7 M8*80mm</p>	<p><b>J</b></p>  <p>Washer*7</p>
<p><b>K</b></p>  <p>Allen key*1</p>		

# Assembly Instruction-Right Arm Seat

Step 1

Assemble the leg (H) to the left seat frame (B).

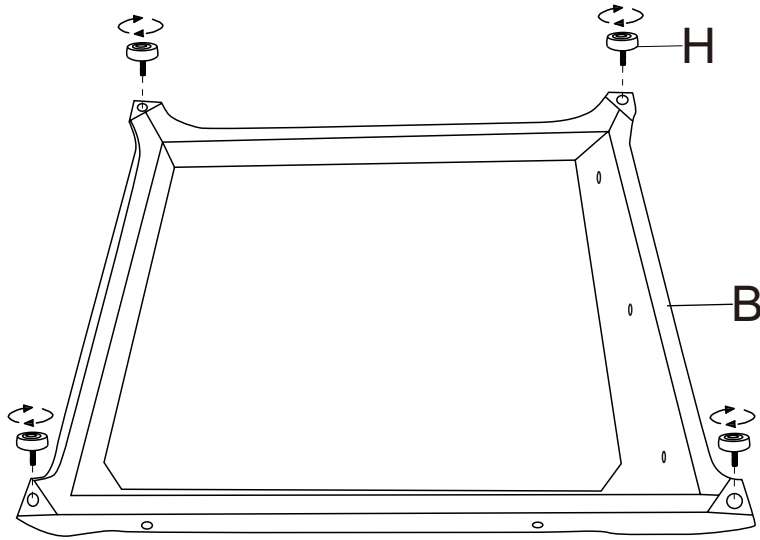

Step 2

Pre-assemble the arm (F) with Bolts (I).

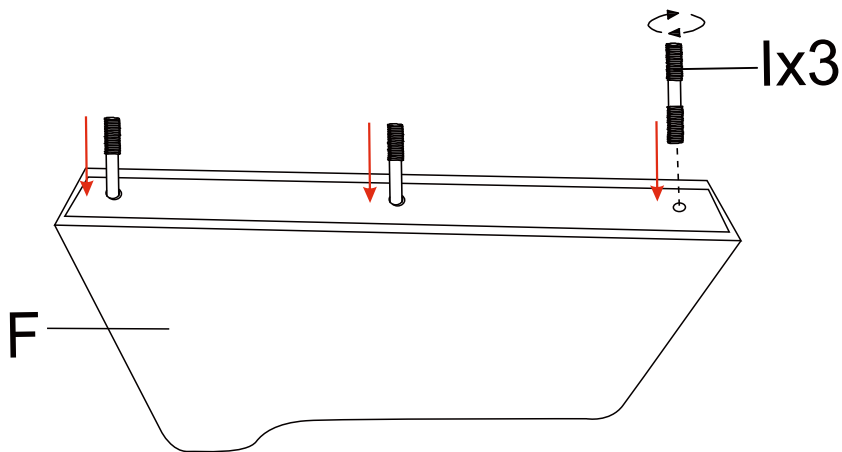

## Step 3

Pre-assemble the backrest ( C ) with Bolts ( I ).

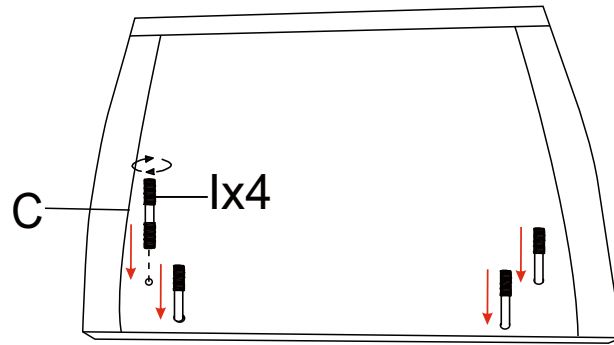

## Step 4

Assemble the arm ( F ) to the left seatframe ( B ) with washer ( J ).

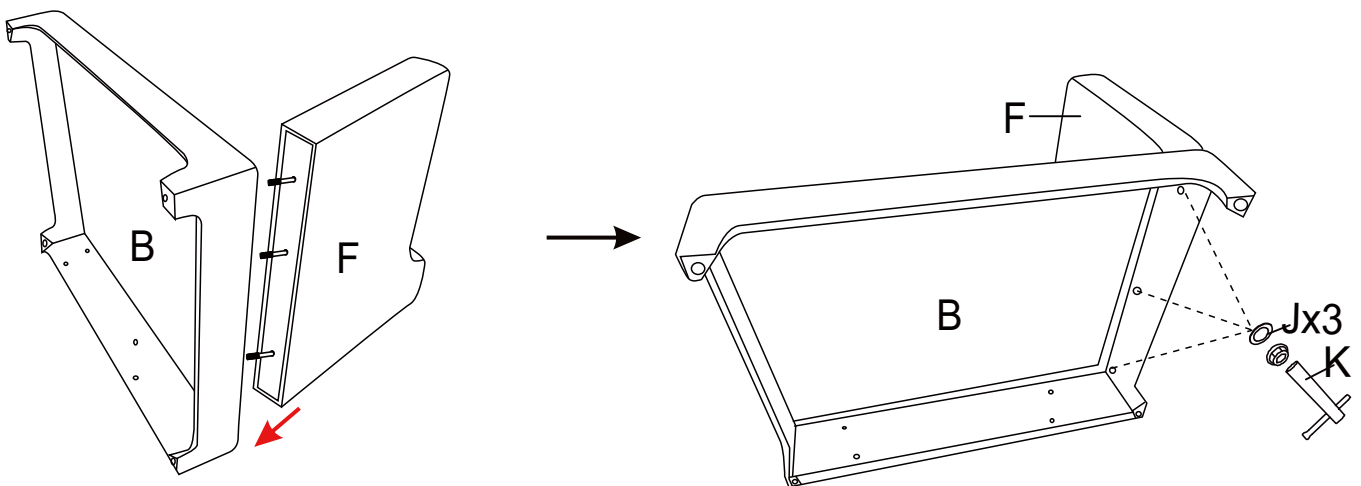

## Step 5

Assemble the backrest(C) to the left seat frame(B) with washer(J).

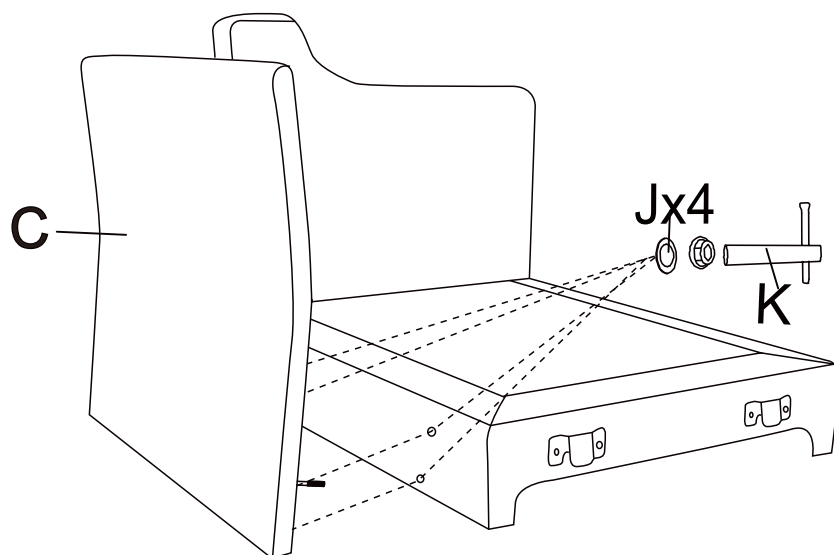

## Step 6

Put back cushion(E) and seat cushion (D) to the sofa.

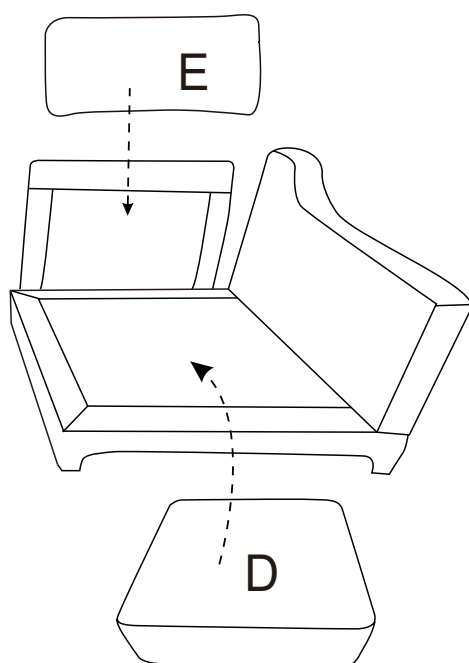

Step 7

Put pillow (G) to the sofa.

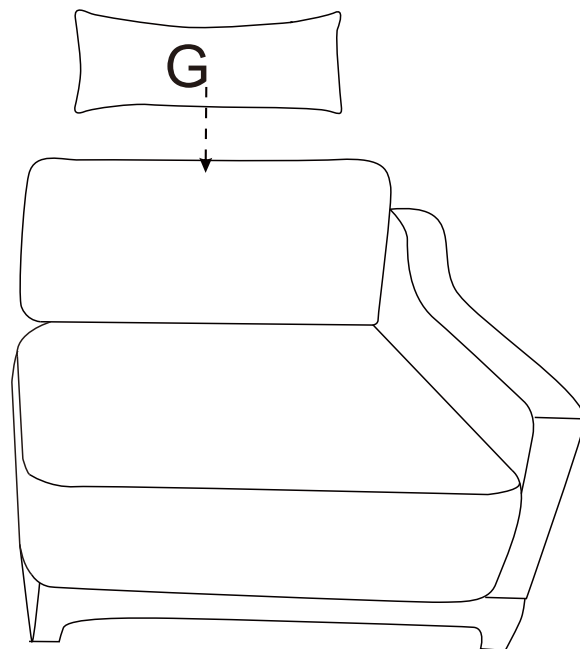

Step 8

Completed .

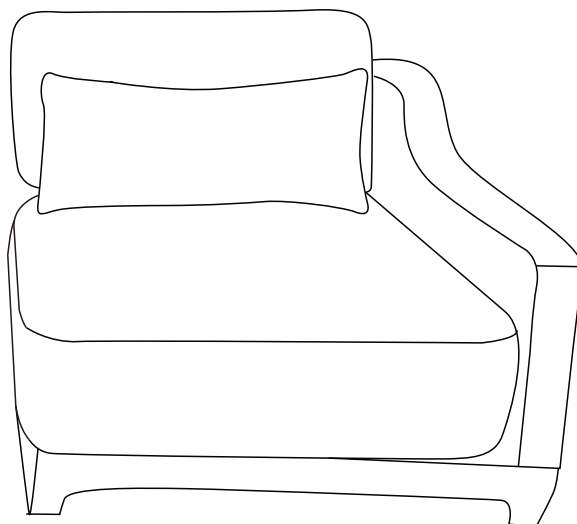

## Assembly Instruction

Please install according to the combination method purchased

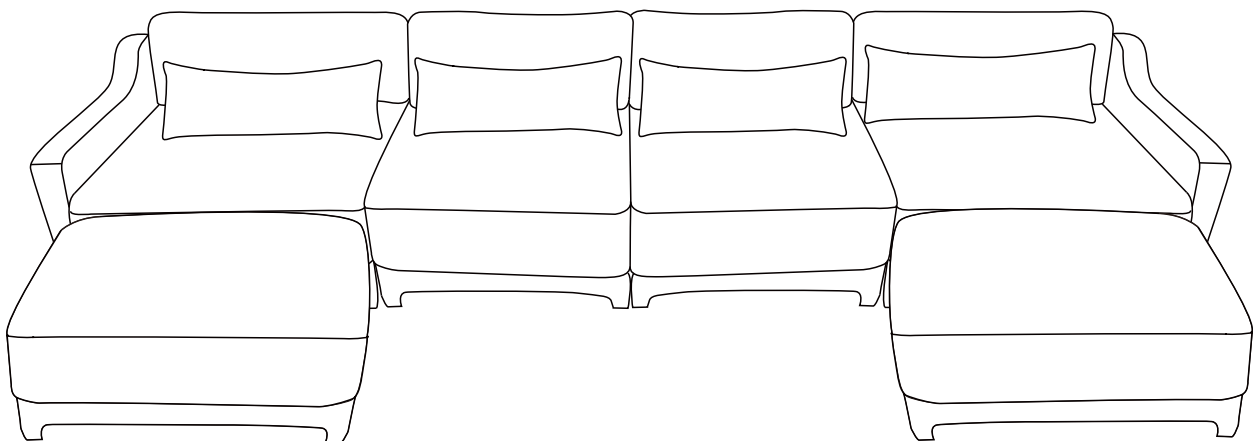
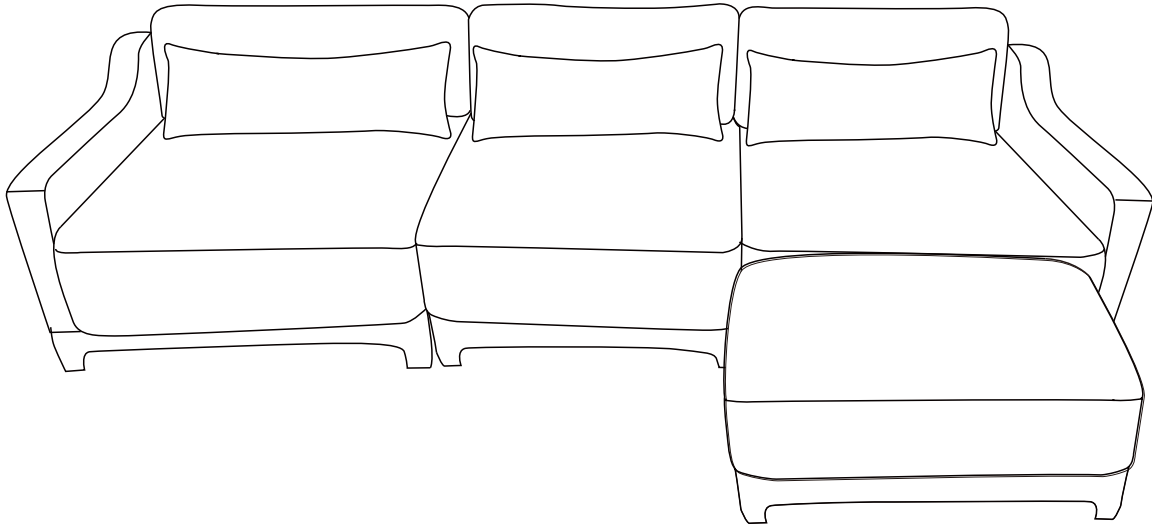

Note: Cushions are vacuum-packed & it may take approximately 72 hours to fully expand to their intended size & shape