

Coffee Table

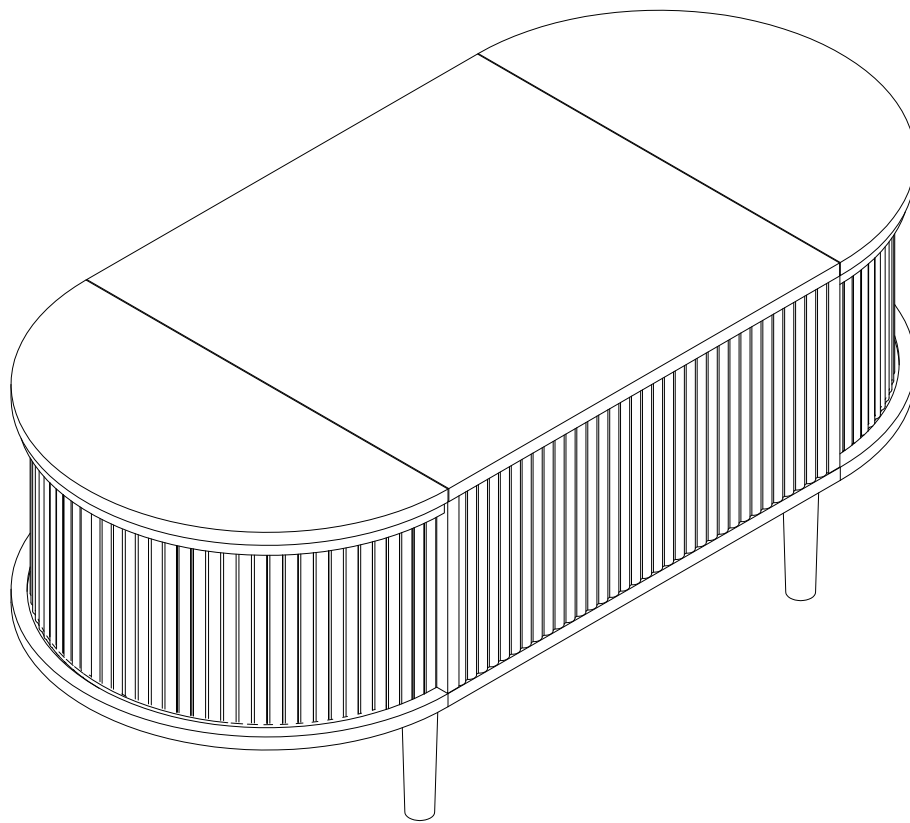

Customer Service Before Return:

If part is missing or damaged, or you need help with assembly please do not hesitate to contact us.

SELLER CONTACT INFORMATION:





cpcontacts@163.com

Before Assembly



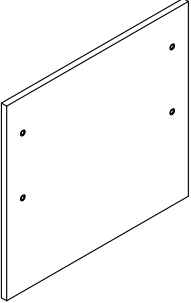
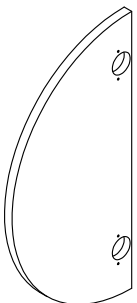
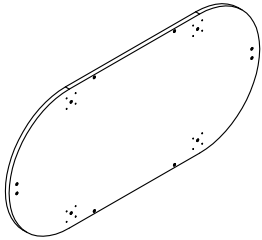
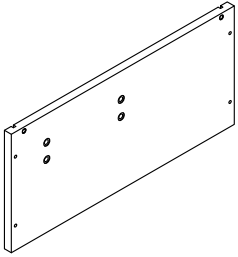
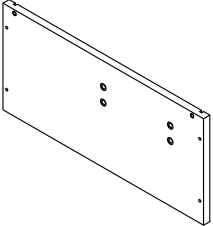
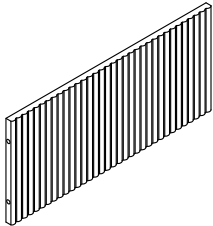

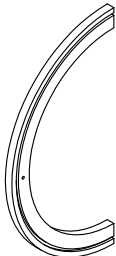
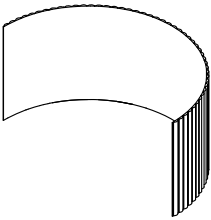

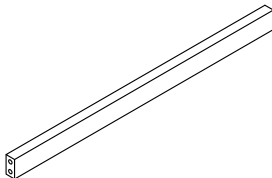



IMPORTANT NOTE :

1. Make sure all parts and hardware are included and free of obvious defect before disposing of any packaging.
2. Place all wooden parts on a clean and smooth surface such as a rug or carpet to avoid the parts from being scratched.
3. Do not tighten all screws and bolts until completely assembled.
4. Assembly will require two people.

Parts List

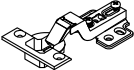
<p>①</p>  <p>1PC</p>	<p>②</p>  <p>2PCS</p>	<p>③</p>  <p>1PC</p>	<p>④</p>  <p>1PC</p>
<p>⑤</p>  <p>1PC</p>	<p>⑥</p>  <p>2PCS</p>	<p>⑦</p>  <p>2PCS</p>	<p>⑧</p>  <p>2PCS</p>
<p>⑨</p>  <p>2PCS</p>	<p>⑩</p>  <p>4PCS</p>	<p>⑪</p>  <p>1PC</p>	

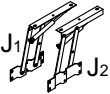
Hardware

<p>A</p> <p>X10</p>  <p>M6x35mm</p>	<p>B</p> <p>X10</p> 	<p>C</p> <p>X1</p>  <p>4mm</p>	<p>D</p> <p>X40</p>  <p>M3.5x14</p>	<p>E</p> <p>X16</p>  <p>M5x40mm</p>	<p>F</p> <p>X4</p> 
<p>G</p> <p>X12</p>  <p>M6x12mm</p>	<p>H</p> <p>X4</p> 	<p>I</p> <p>X4</p> 	<p>J</p> <p>X2</p>  <p>J₁ J₂</p>	<p>K</p> <p>X4</p>  <p>M6x22mm</p>	

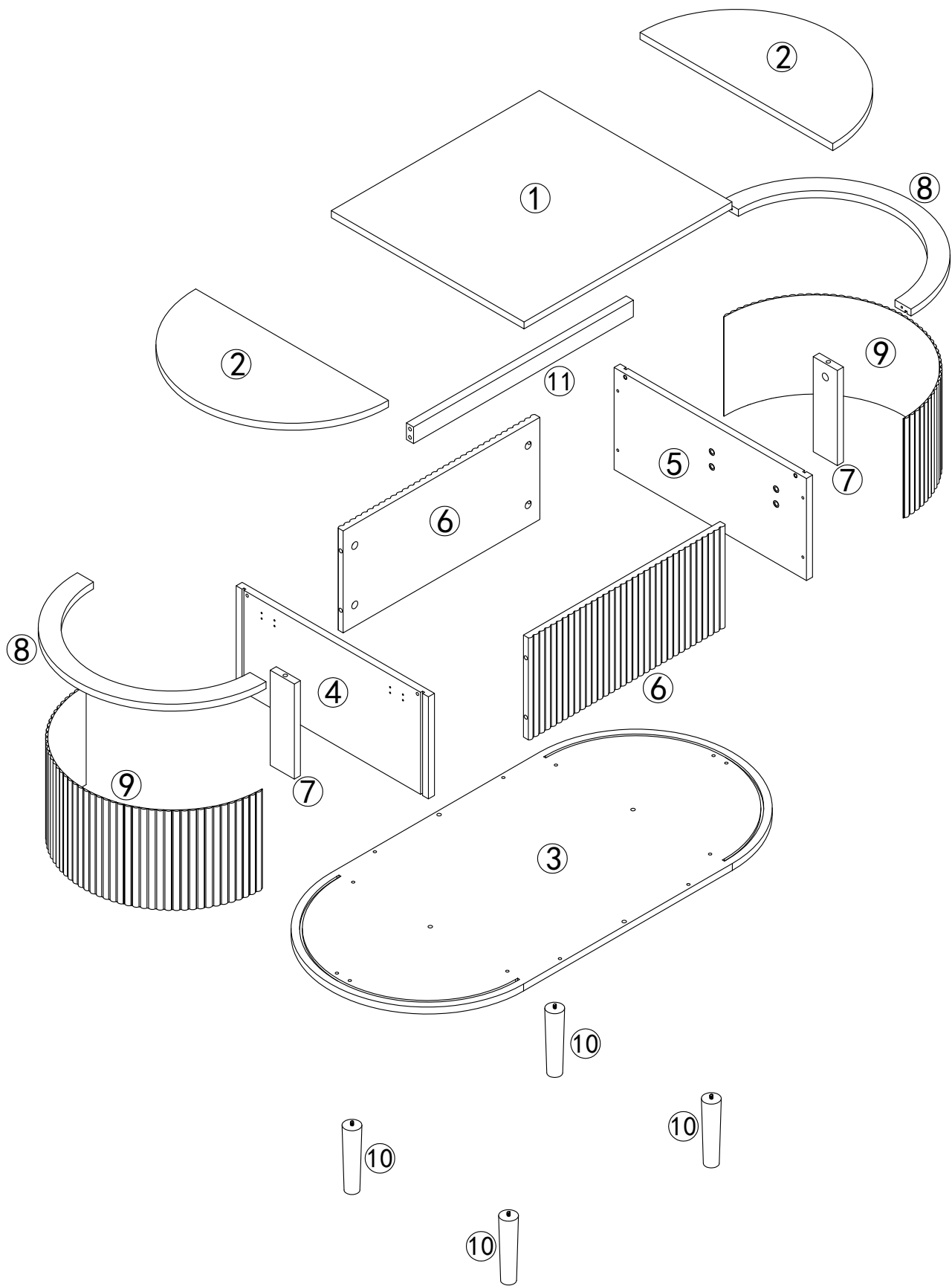

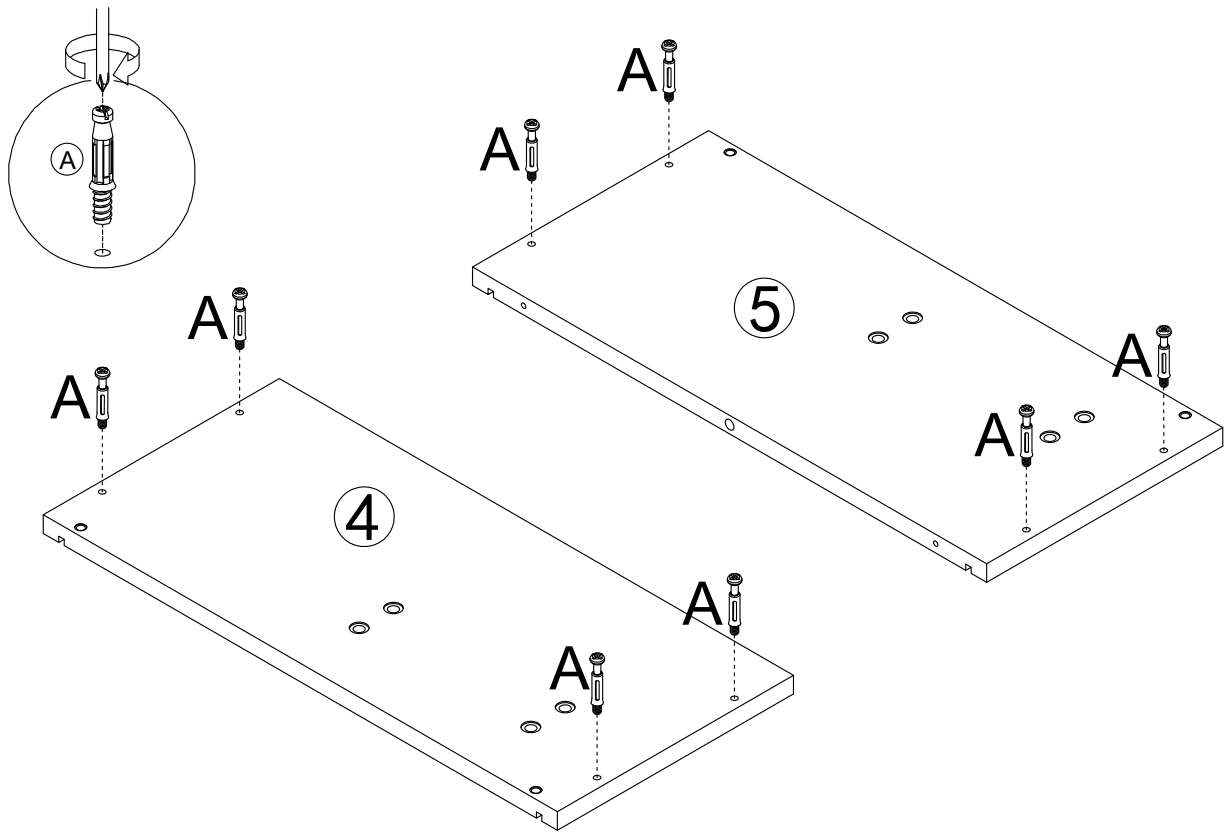

1



A	X8
	
M6x35mm	

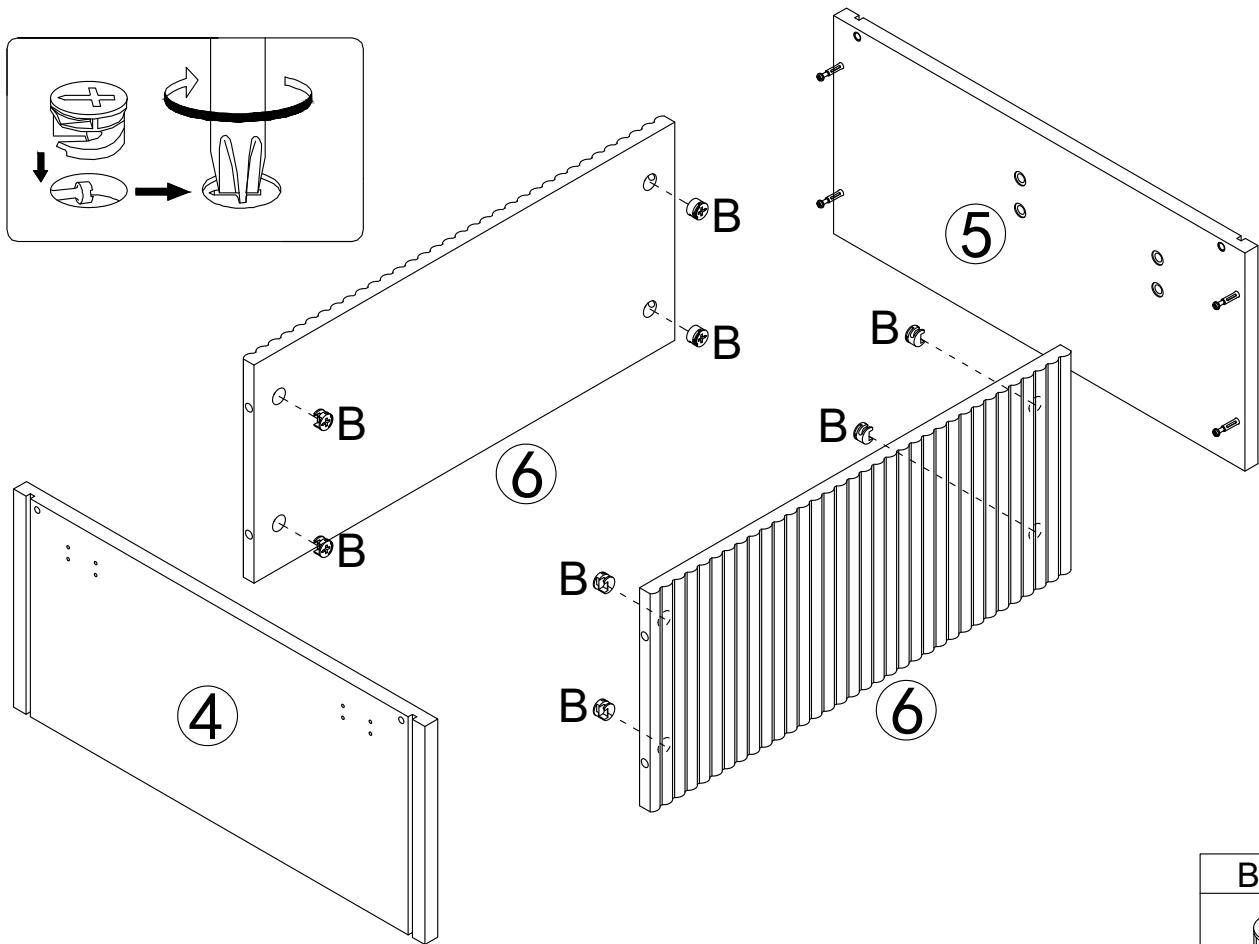

2

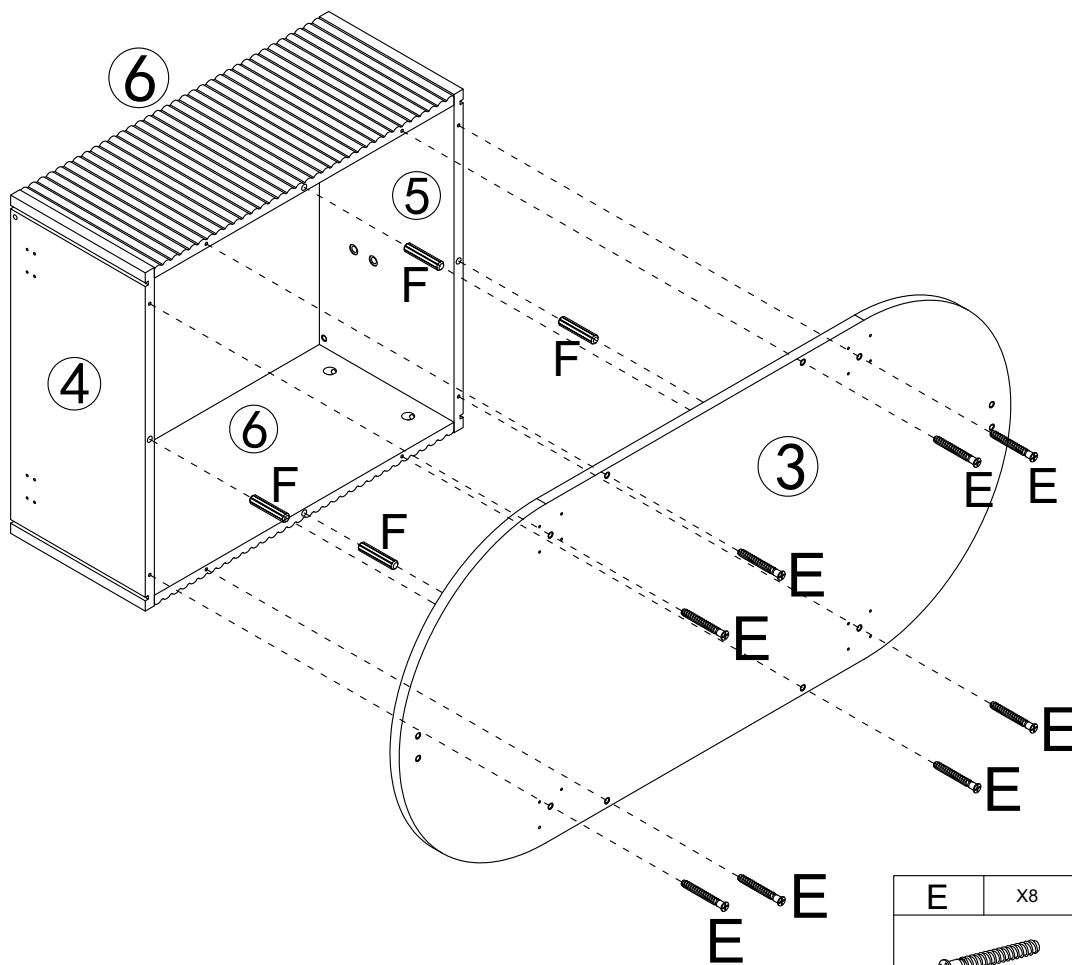

B	X8
	

3



E	X8	F	X4
			
M5x40mm			

4

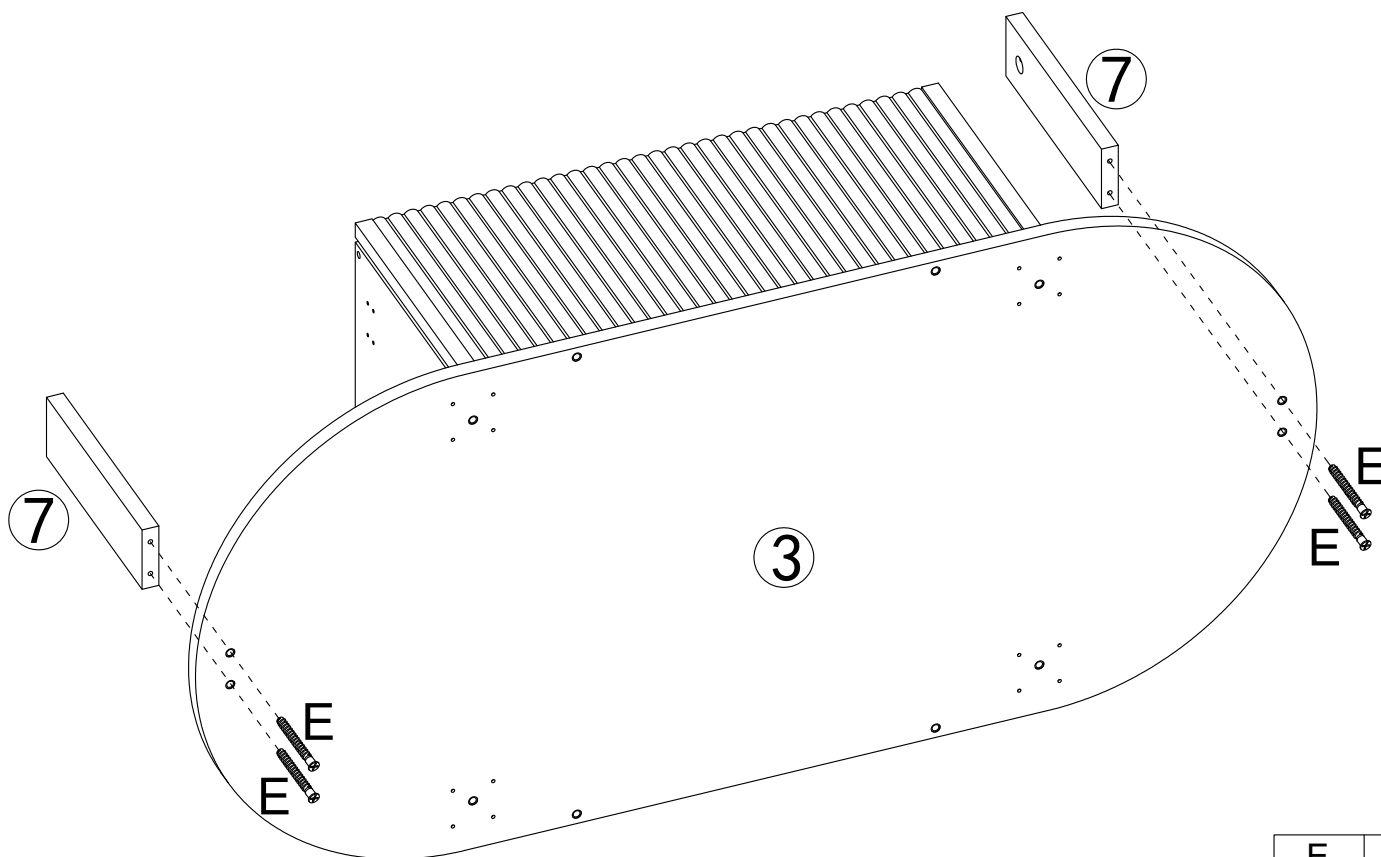

E	X4
	
M5x40mm	

5

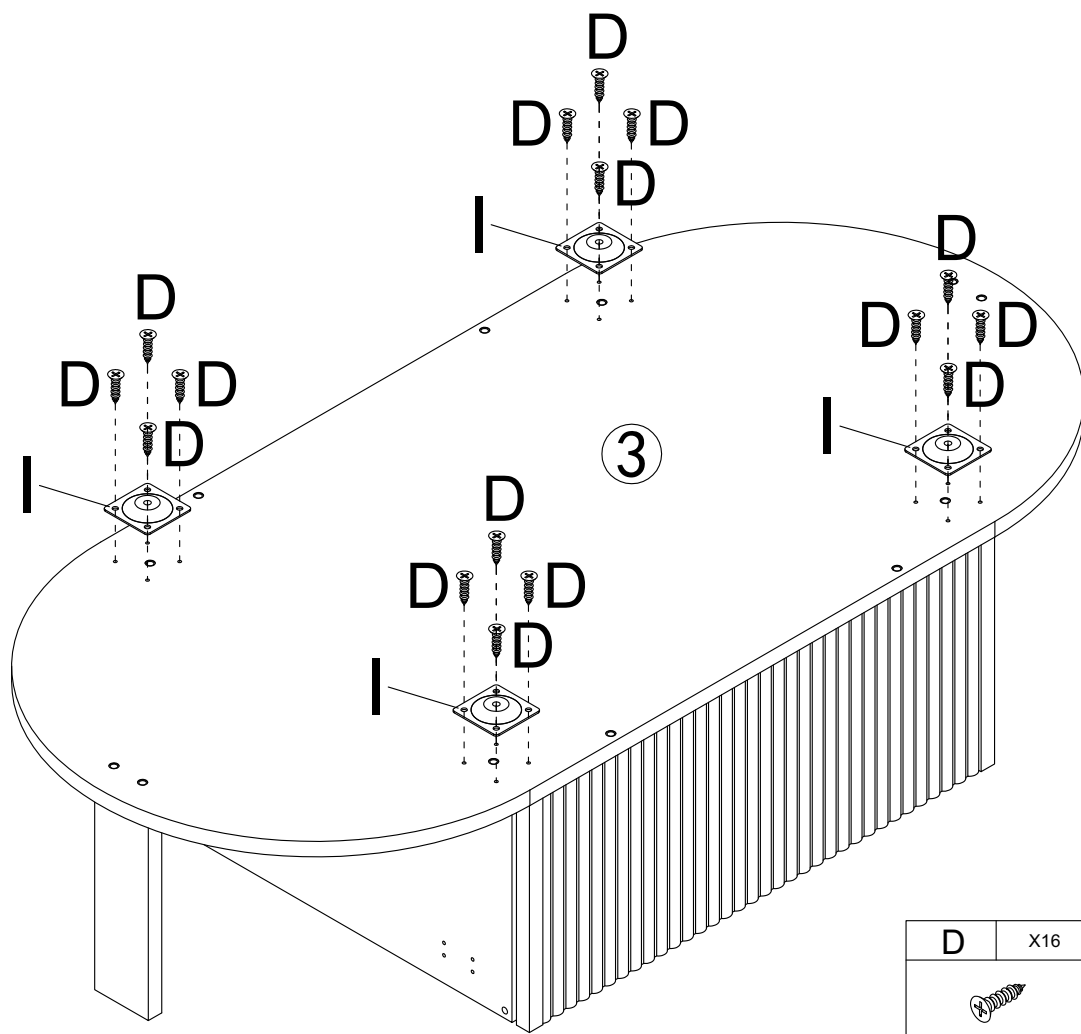

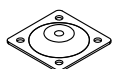

D	X16	I	X4
			
M3.5x14			

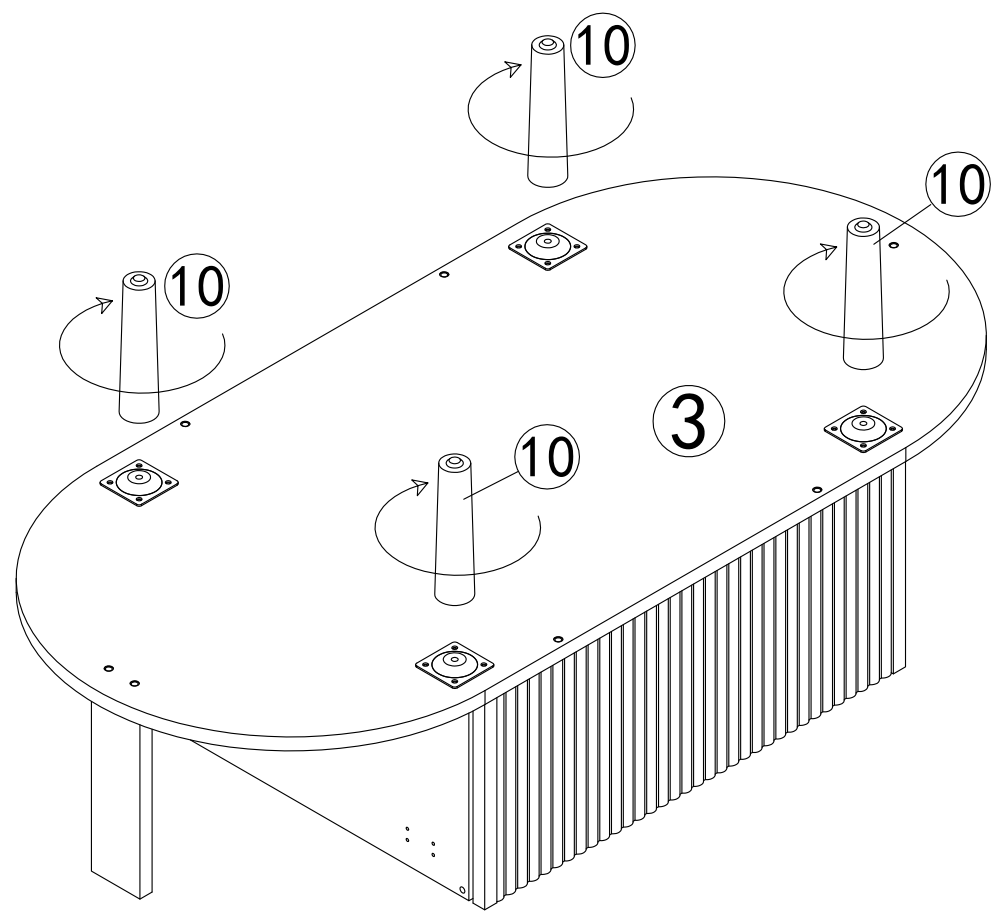
6



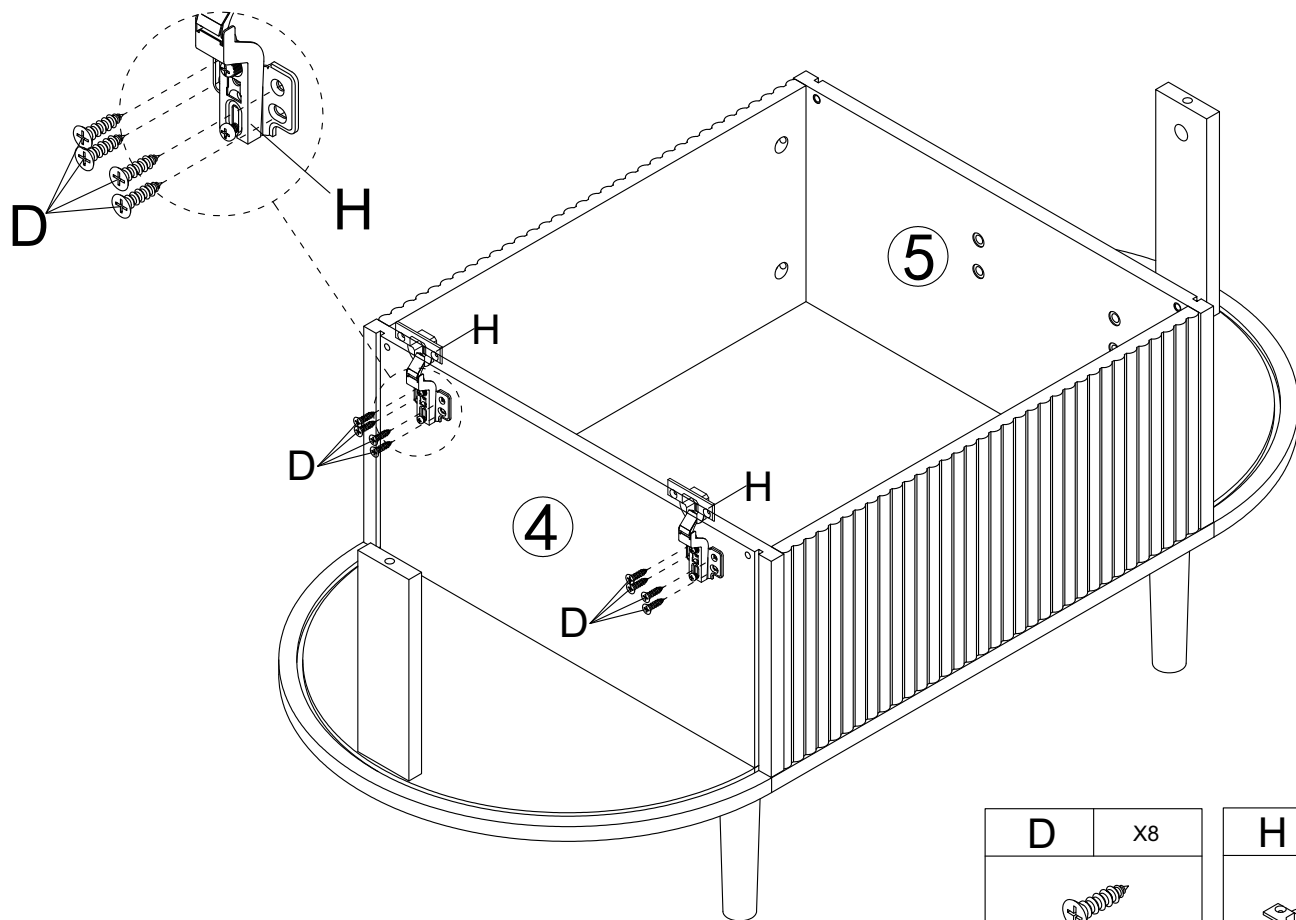

7

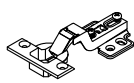

D	X8	H	X2
			
M3.5x14			

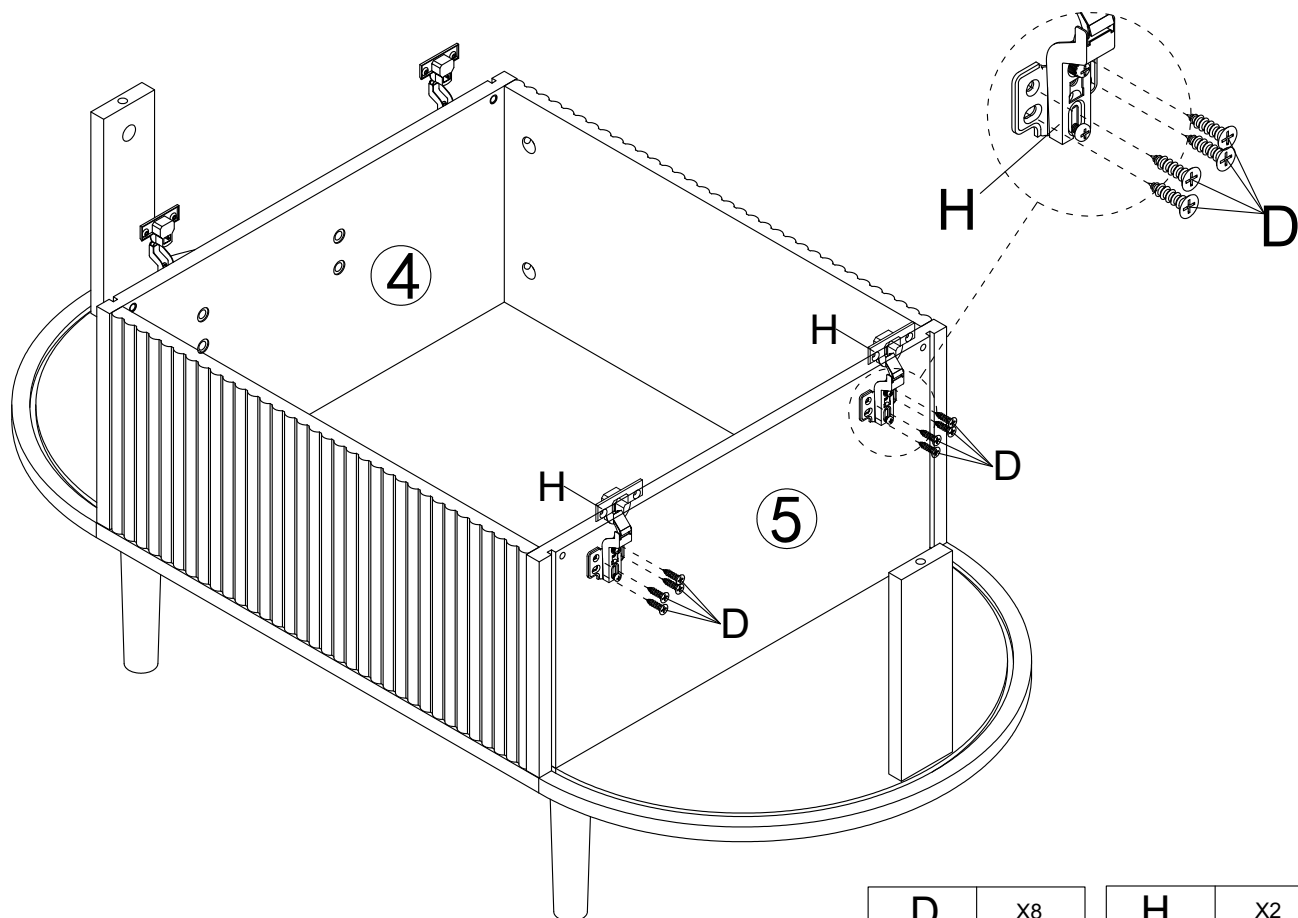
8

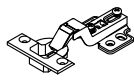

D	X8	H	X2
			
M3.5x14			

9

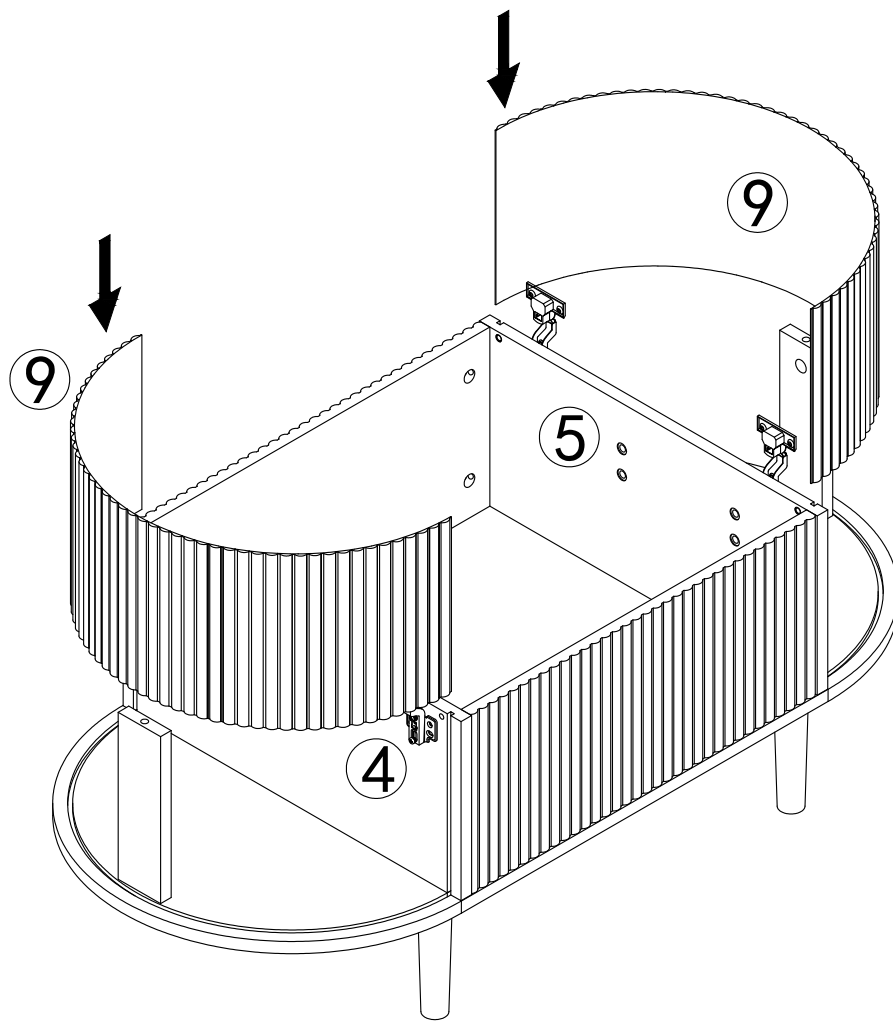

10

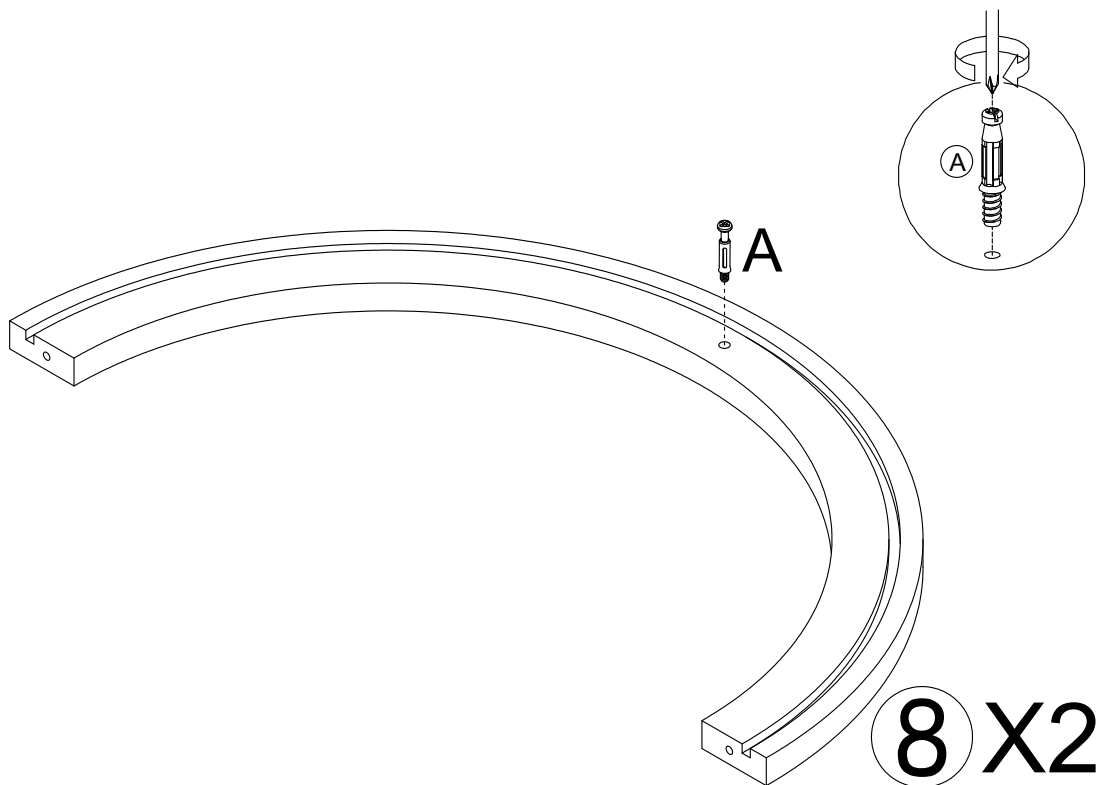

8 X2

A	x2
M6x35mm	

11

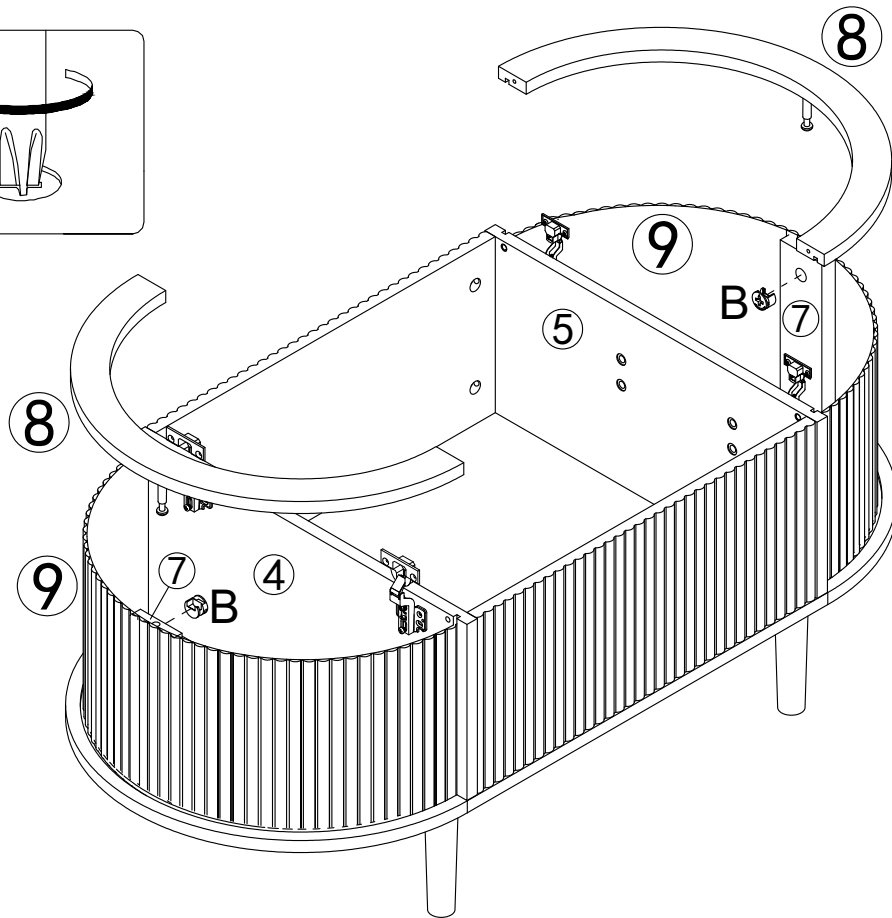
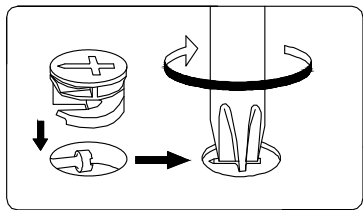

B	x2

12

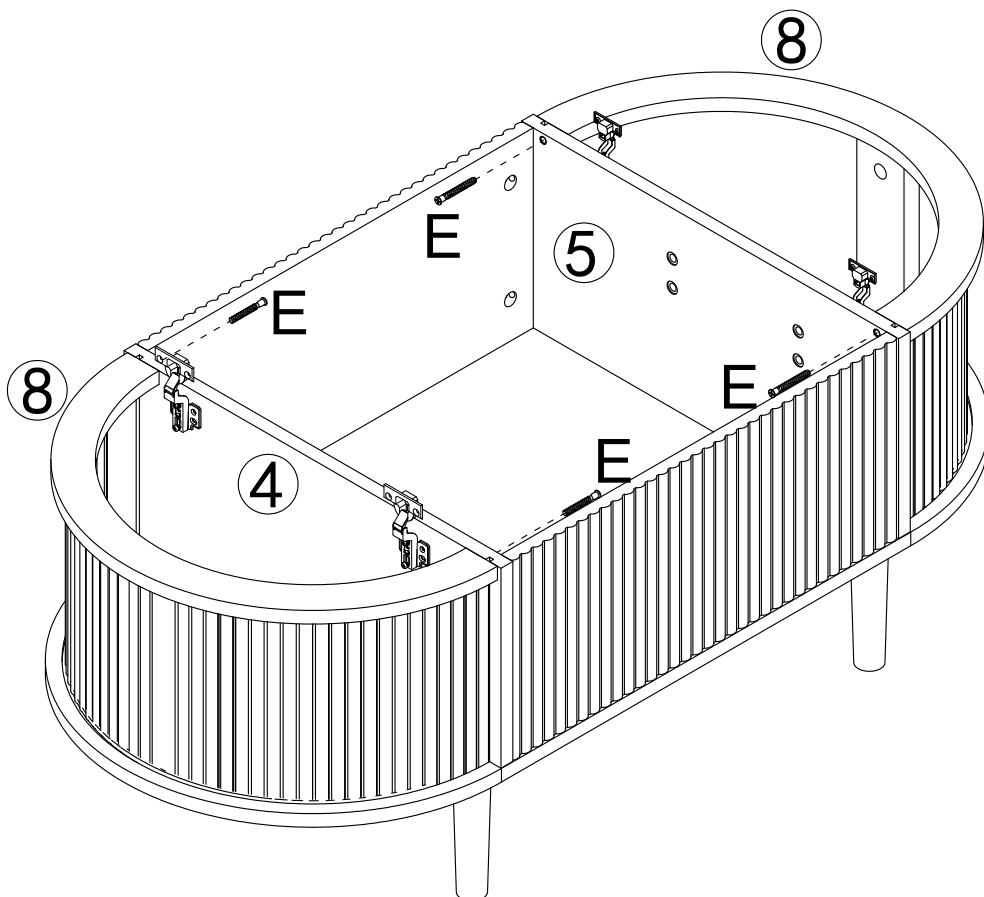

E	x4
M5x40mm	

13

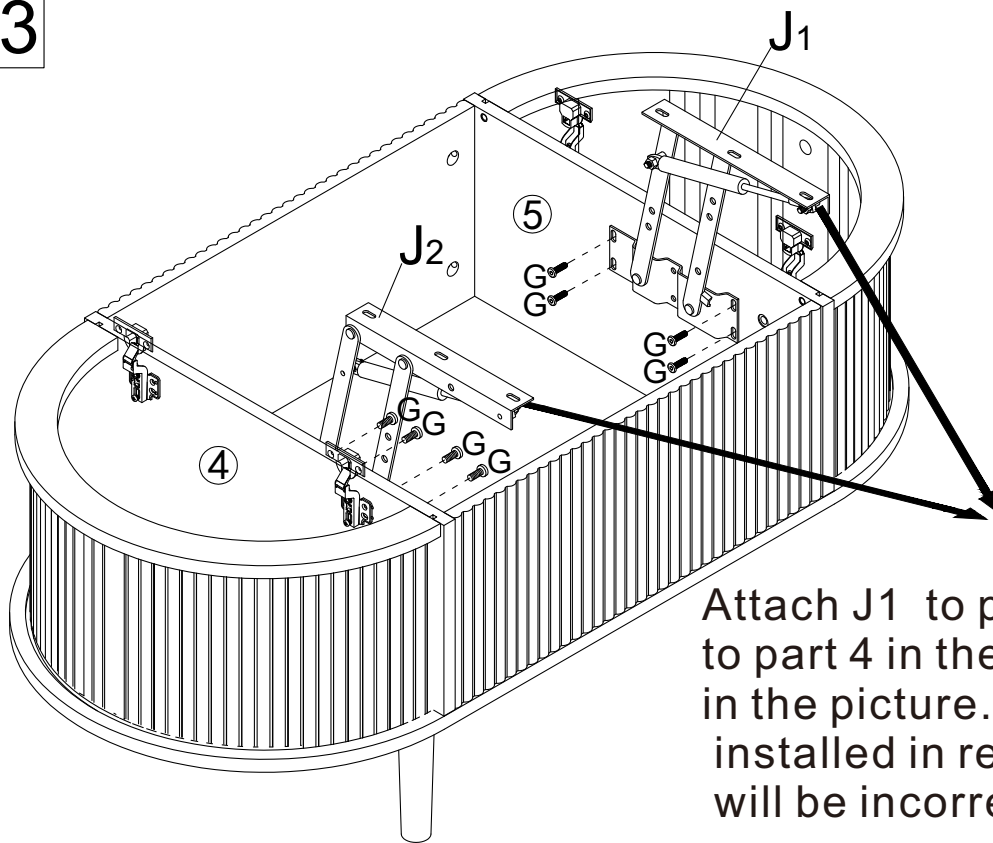

Attach J1 to part 5 and attach J2 to part 4 in the orientation shown in the picture. If this end is installed in reverse, the assembly will be incorrect.

G	x8
M6x12mm	

J	x2

14

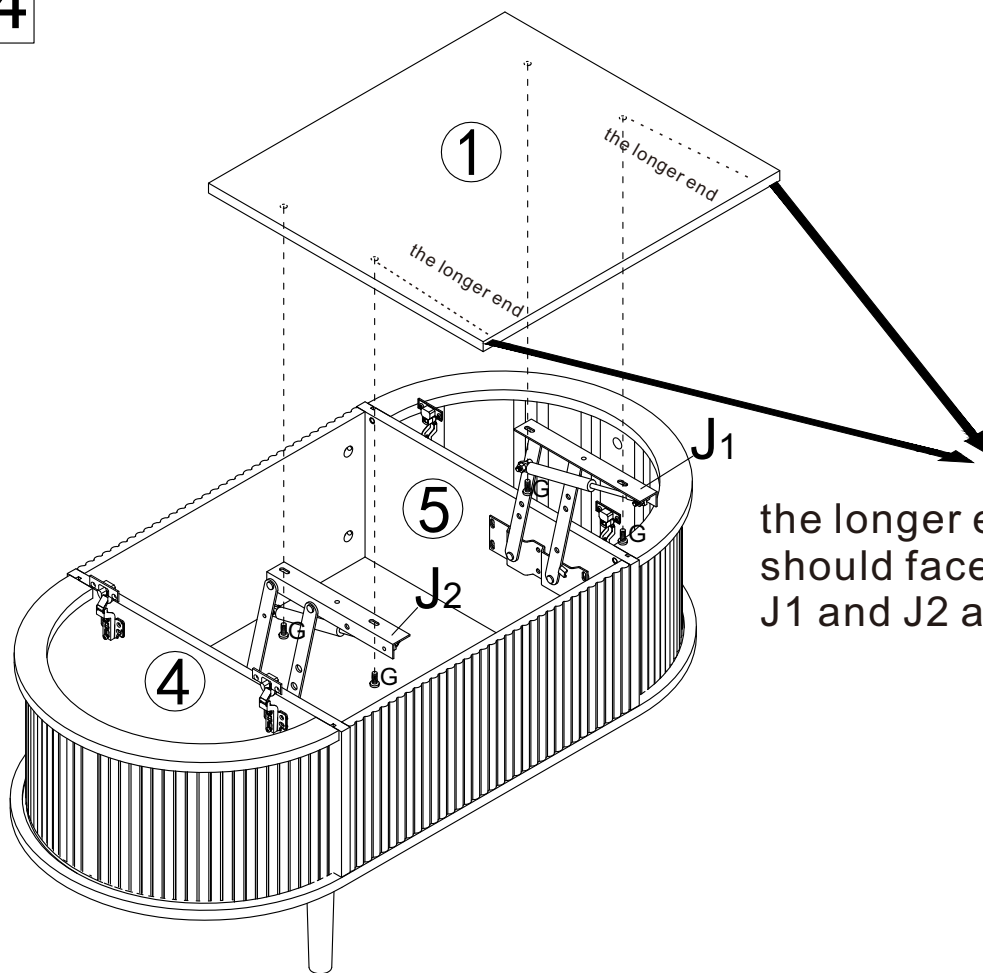

the longer end of table top(part 1) should face the same direction of J1 and J2 as shown in the picture.

G	x4
M6x12mm	

15

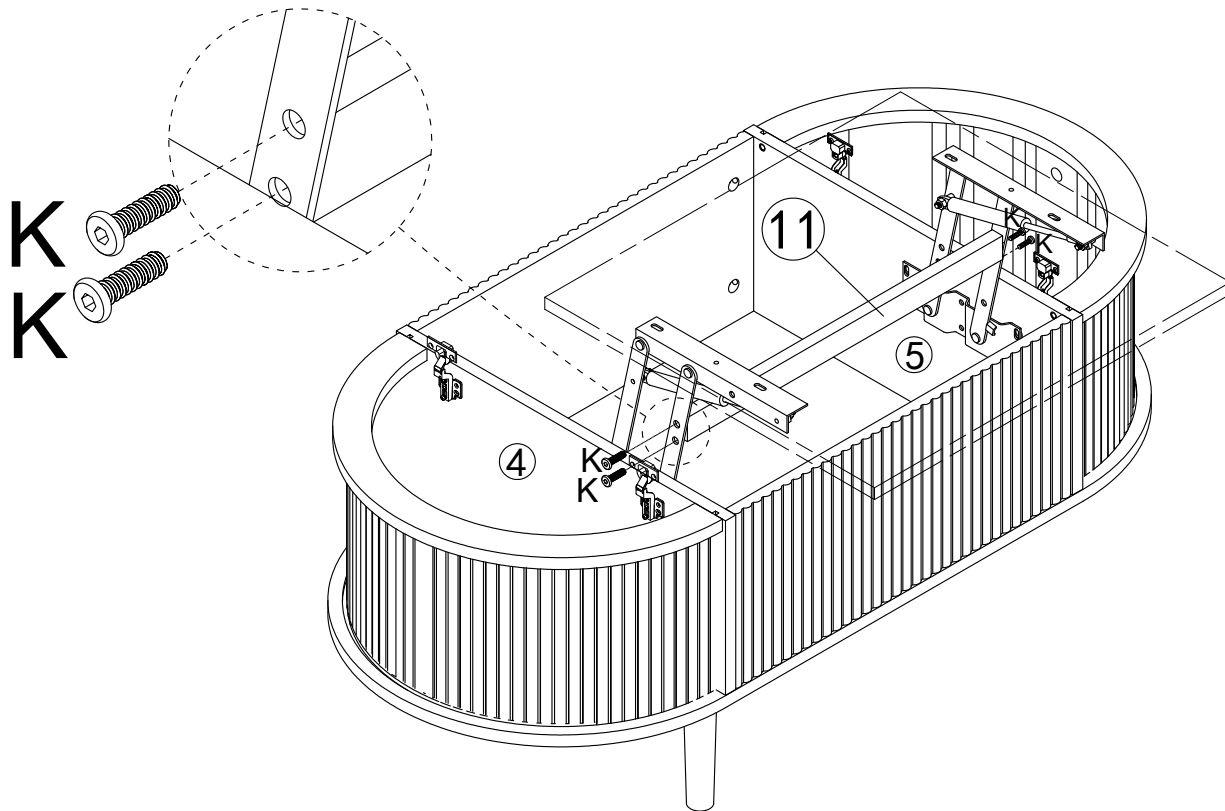

K	x4
	
M6x22mm	

16

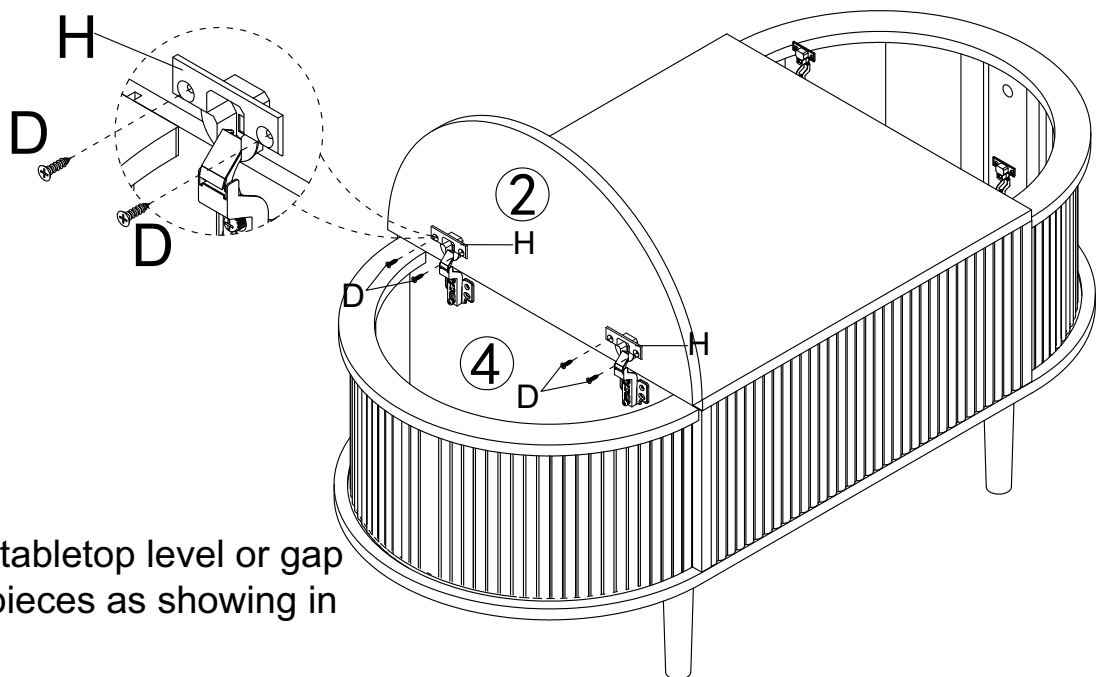

Please adjust tabletop level or gap between two pieces as showing in the picture

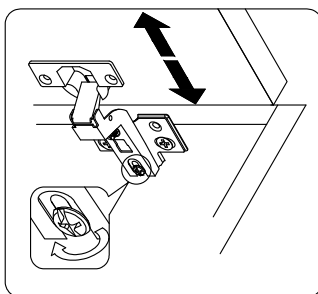

Adjust the height by this

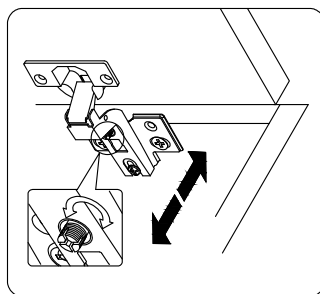

Adjust the gap by this

D	x4
	
M3.5x14	

17

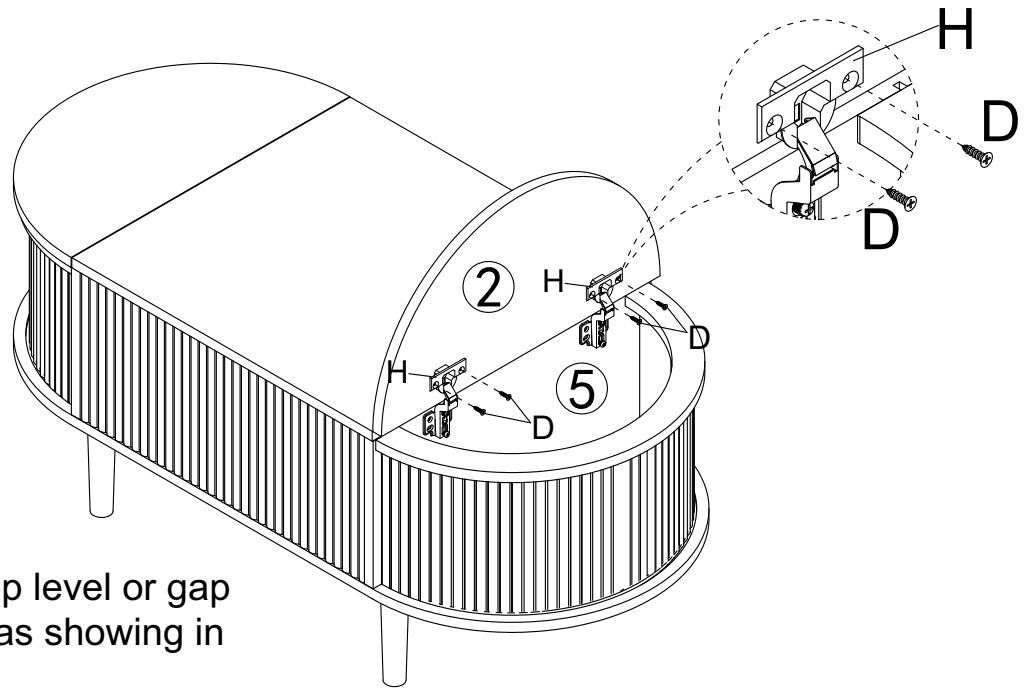

Please adjust tabletop level or gap between two pieces as showing in the picture

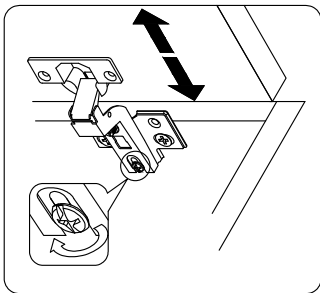

Adjust the height by this

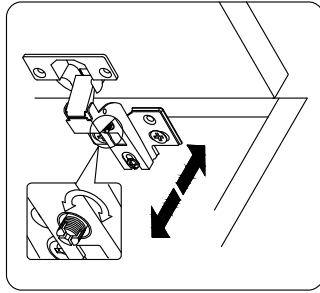

Adjust the gap by this

D	X4
	
M3.5x14	

18

