



Washplane
Geo / Sensi / Linea / Onda

Installation
Care & Maintenance
Warranty

Plumbers - Please leave this booklet with the homeowner



Pre-Installation Checks

Please take time to read and perform these checks before proceeding to installation instructions.

This product must be installed by a qualified trade's person in a professional manner.

Caution: When lifting or installing heavy items always seek assistance, never attempt to lift or maneuver alone. Always follow safe practices and use personal protective equipment (PPE).

1. Inspect all items upon delivery.

If you believe there is a fault, damage or the item is incorrect, contact the place of purchase immediately. Proceeding with installation will immediately void warranty. The manufacture will not be liable for installation or removal costs.

Omvivo allow 7 days from receipt of goods for notification of any discrepancies in goods received.

2. Read instructions carefully before beginning installation.

3. See specification details for spout / faucet details.

Incorrect spout / faucet selection may result in too much pressure, excess water or splashing.

FAILURE TO ADHERE TO THE ABOVE PREPARATION OR INSTALLATION INSTRUCTION WILL VOID YOUR WARRANTY

Please inspect items upon delivery.

If you believe there is a fault, damage or the item is incorrect contact the place of purchase immediately.
DO NOT PROCEED WITH INSTALLATION.

ONCE INSTALLED NO CLAIMS OF DAMAGE WILL BE ACCEPTED

Omvivo allow 7 days from receipt of goods for notification of any discrepancies in goods received.

SINGLE 800 OR 1200 WASHPLANE ASSEMBLY LIST

Figure 1.

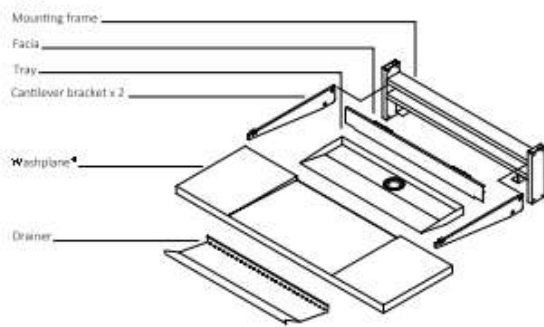

DOUBLE 1600 OR 1200 WASHPLANE ASSEMBLY LIST

Figure 2.

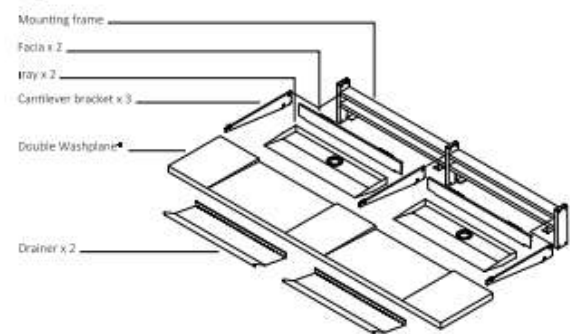

TRIPLE 2250 WASHPLANE ASSEMBLY LIST

Figure 3.

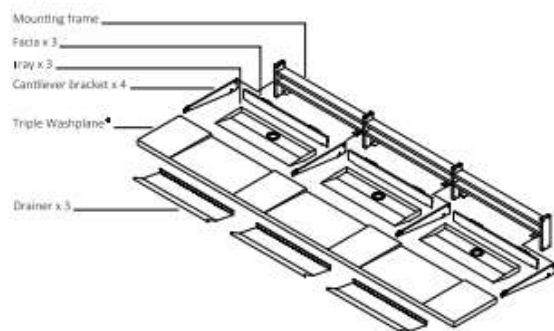

SINGLE WASHPLANE PRE-INSTALLATION

Stud wall set-out:

Figure 4.
SINGLE 800 (500mm SLUMP)

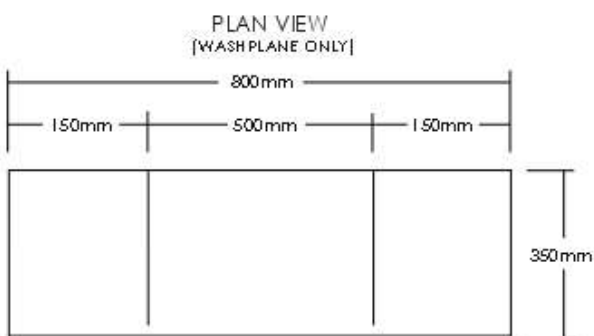
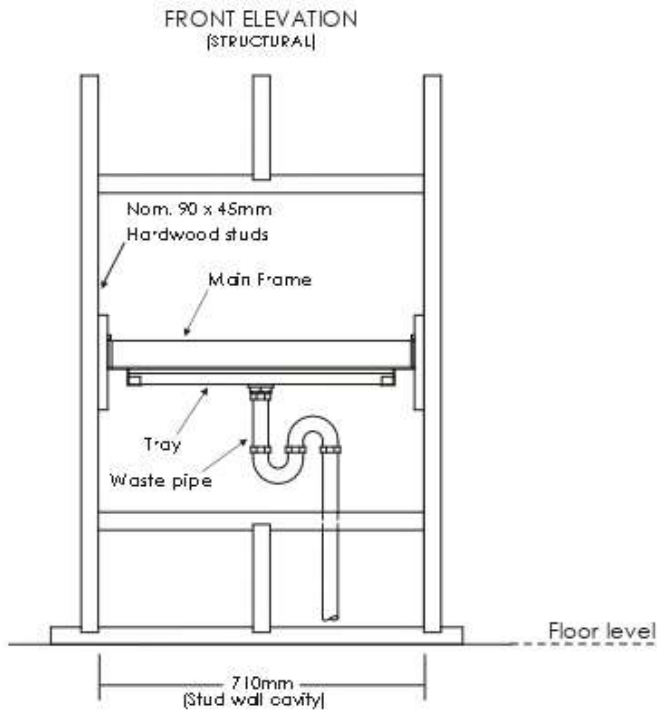
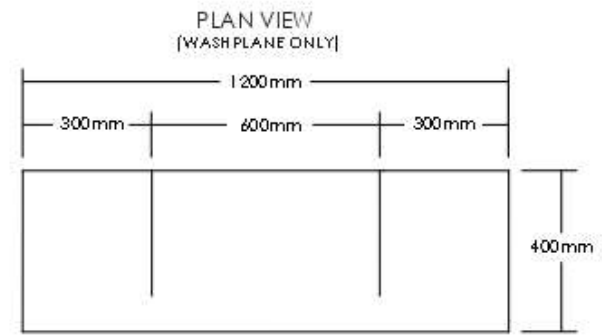
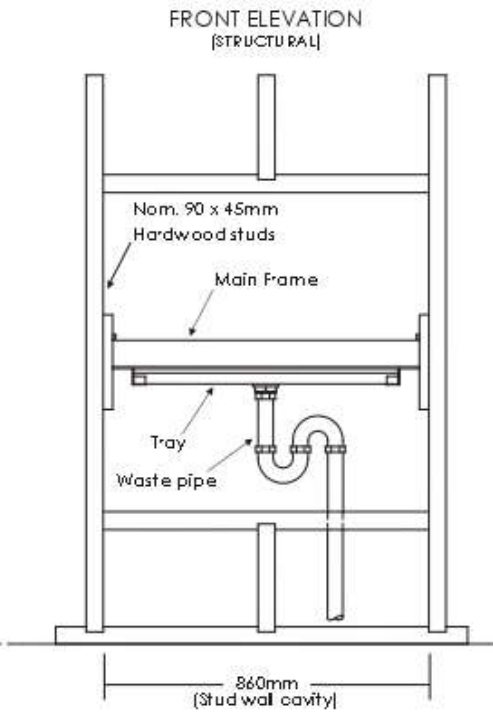

Figure 5.
SINGLE 1200 (600mm SLUMP)



* Note: Please provide this information to the project manager for consultation prior to beginning of works.

(structural or load bearing walls may require additional overhead support)

DOUBLE WASHPLANE PRE-INSTALLATION

Stud wall set-out:

Figure 6.

DOUBLE 1600 (500mm SLUMP)

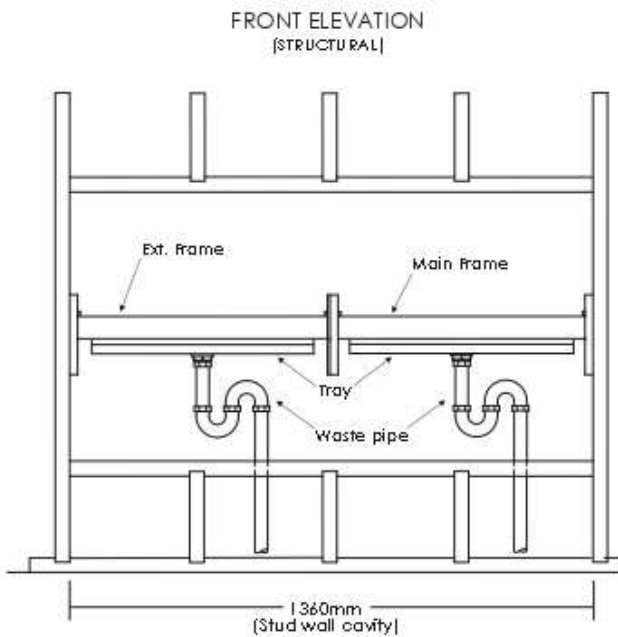
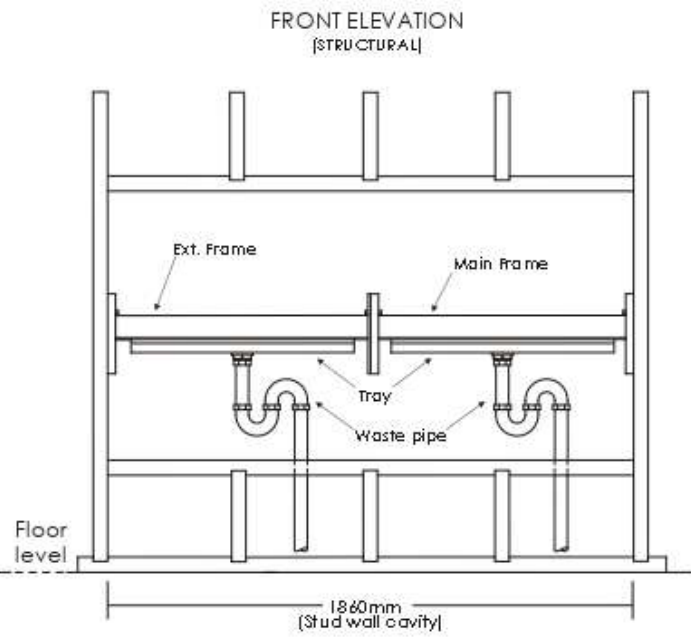
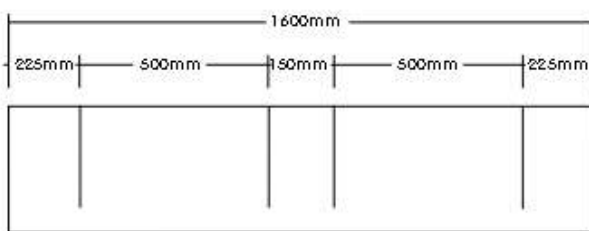

Figure 7.

DOUBLE 2100 (600mm SLUMP)



PLAN VIEW
(WASHPLANE ONLY)



PLAN VIEW
(WASHPLANE ONLY)

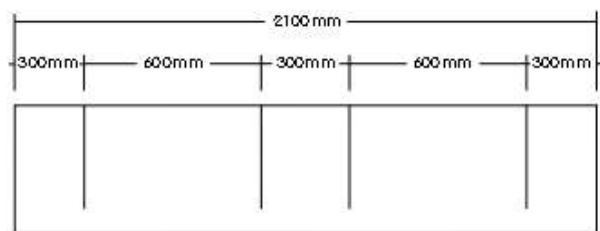

* Note: Please provide this information to the project manager for consultation prior to beginning of works.

(structural or load bearing walls may require additional overhead support)

TRIPLE WASHPLANE PRE-INSTALLATION

Stud wall set-out:

Figure 8.

Triple 2250 (500mm SLUMP)

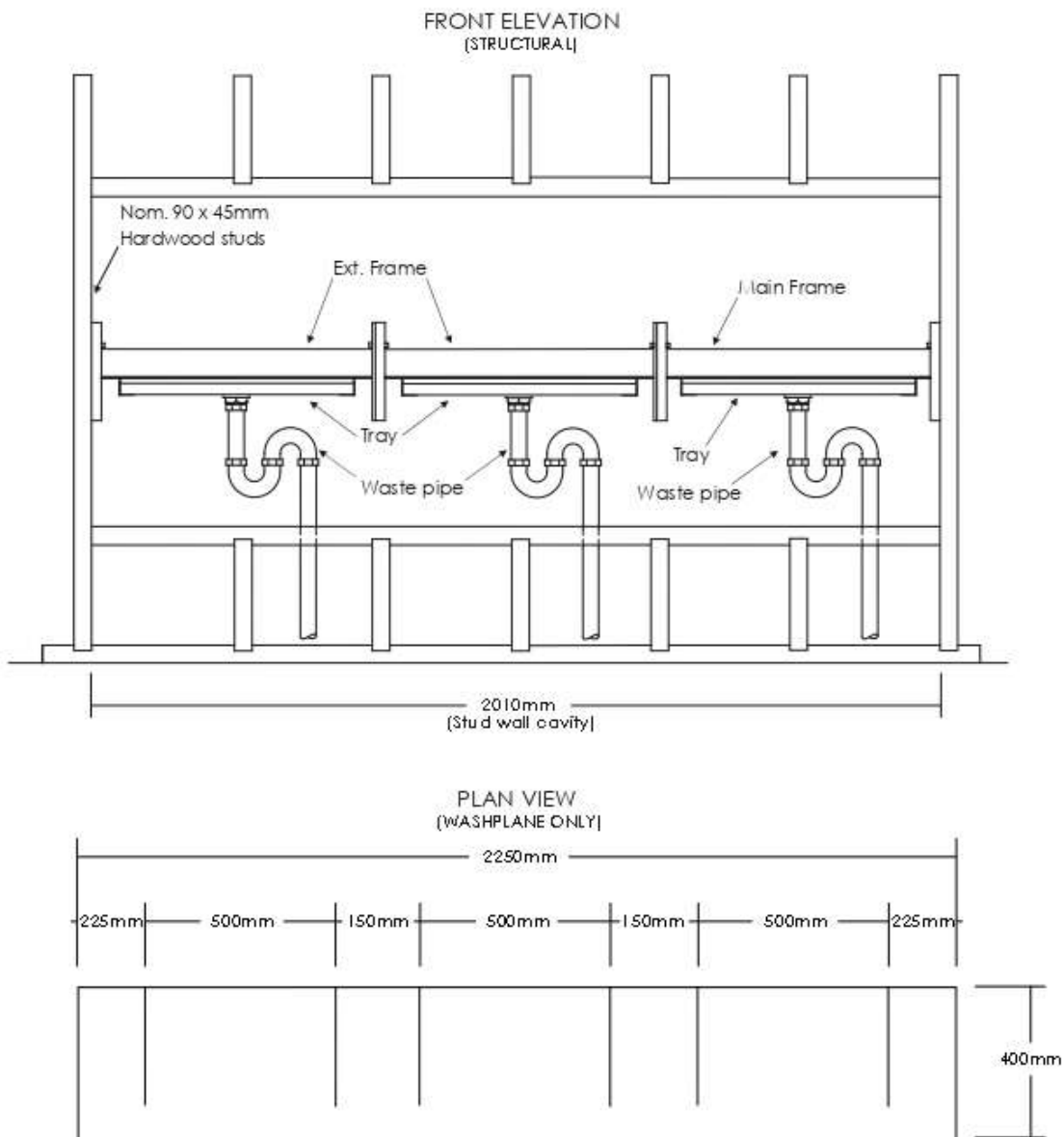

* Note: Please provide this information to the project manager for consultation prior to beginning of works.

(structural or load bearing walls may require additional overhead support)

WASHPLANE FINISHING HEIGHTS

Figure 9.

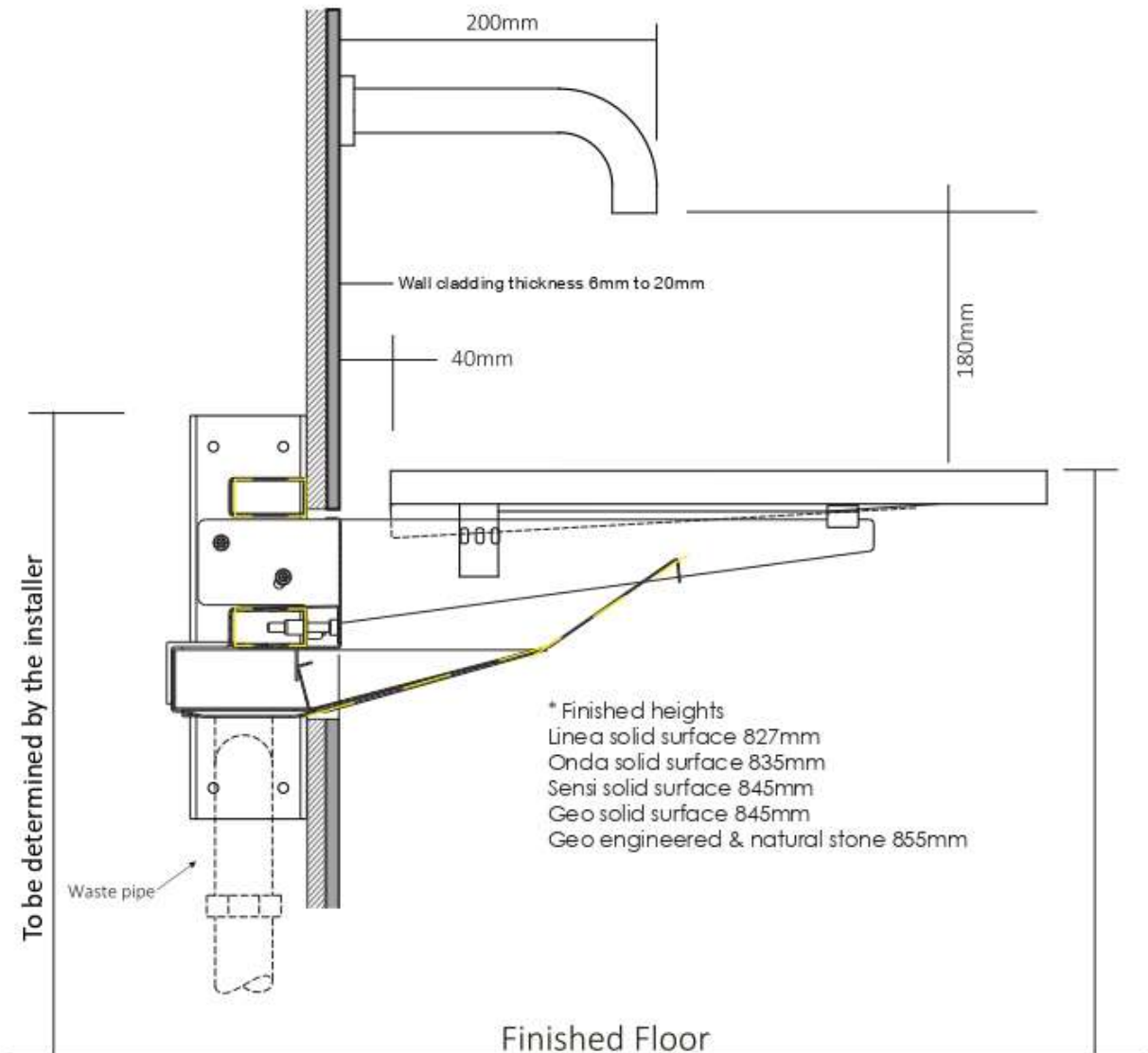

* For disabled bathrooms 770-800mm as per AS 1428.01-2001
 Refer to figure 9 for finishing height

* Note: The mounting frame is designed to fit into a standard 90mm wall cavity. It is to be fixed between nominal 90 x 45mm hardwood studs or equivalent. Do not scale drawing. The washplane has been designed to be installed without the use of excessive silicon. Please refrain from using silicon to assemble any components. Do not silicone around hardware and finished wall tiles.

WASHPLANE MOUNTING FRAME ASSEMBLY

Assemble cantilever brackets using fixings supplied.

For double and triple, add the extension frame to the main frame using the fixing supplied.

Figure 10.

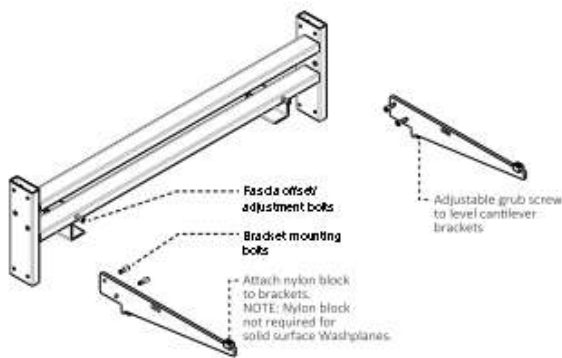

Figure 11.

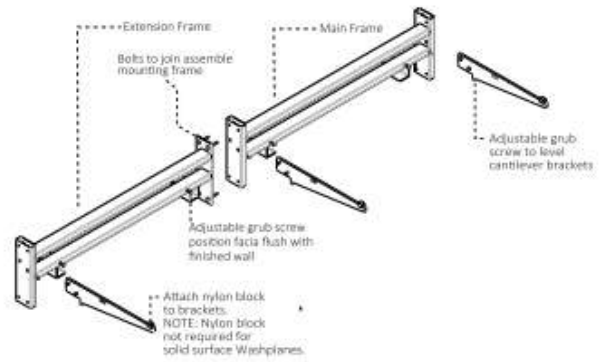
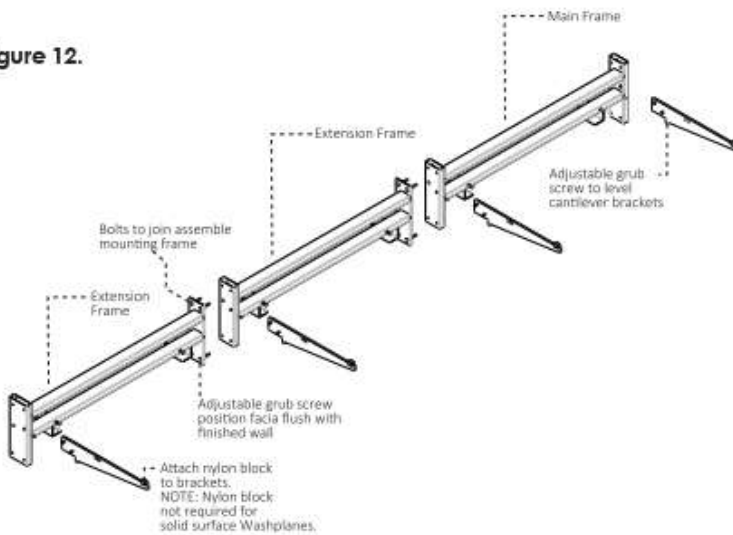
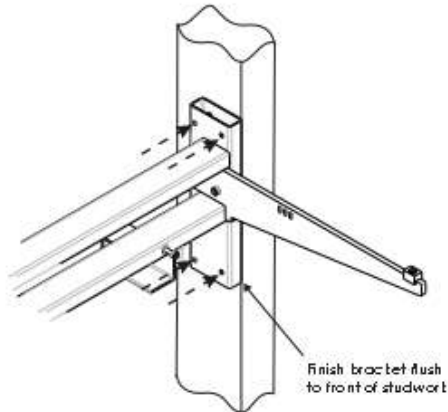

Figure 12.



MOUNTING FRAME HEIGHT

Figure 13.



1. A 90mm wall cavity will need to be created to enclose plumbing and mounting frame. See figure __ for per-installation set out.

2. Fix mounting frame to timber studs with 12 gauge x 2 1/2" coarse thread screws, or similar. Ensure cantilever brackets are plumb and level. See figure 13

WASTE PLUMBING

Figure 14.

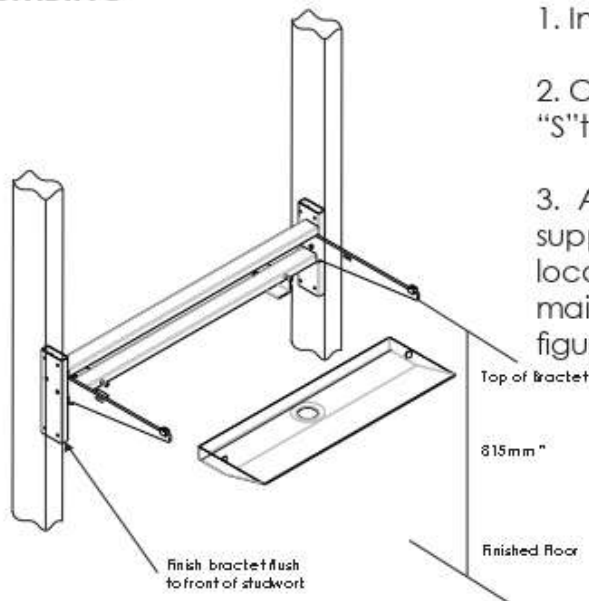

1. Insert tray into mounting frame

2. Connect plug and waste to "P" or "S" trap. Tray should be secure.

3. All plumbing, including water supply and stop taps, should be located under the tray for ease of maintenance and adjustment. See figure 14

* For disable bathrooms this bracket top dimension is to be determined by subtracting selected Washplane thickness. See figure 9 from required finished height.

DRAINER ASSEMBLY

Figure 15.

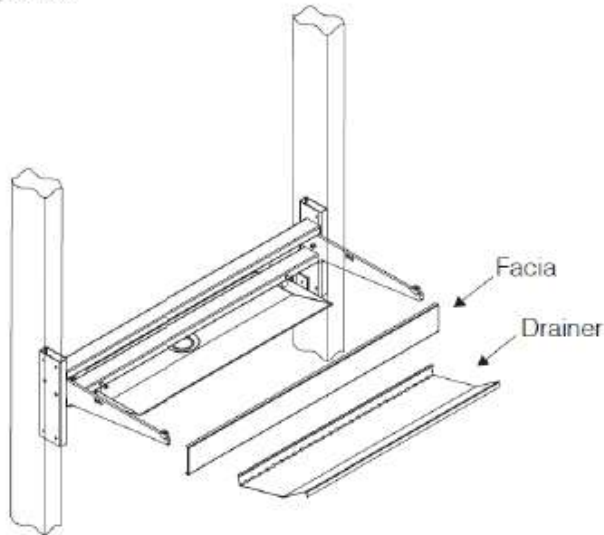

1. Slide drainer into tray. The locating tabs are at the back of the tray which the drainer rests against.

2. The drainer is designed to be removed for cleaning purposes. See Figure 15

* IMPORTANT - Check drainer slides in and out easily before installing Washplane top.

WALL CLOSING AND FINISHING

Figure 16.

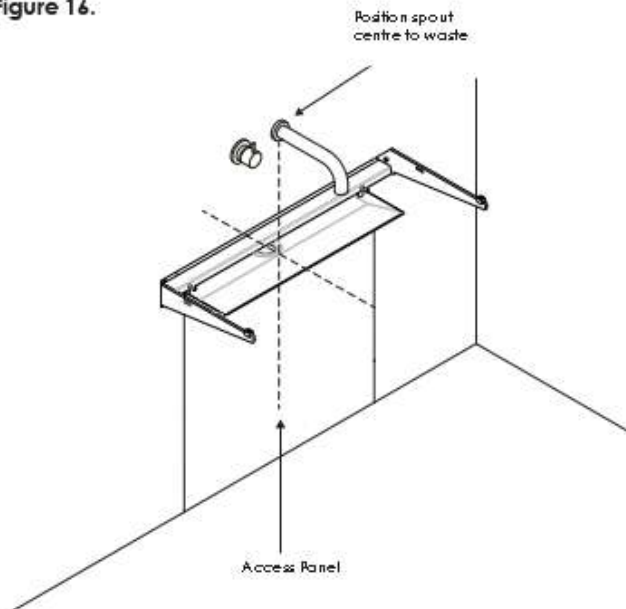

1. Close and finish wall

2. It is recommended to consider access to the plumbing behind your finished wall. This can be achieved by incorporating a removable panel between the bracket arms, or under the tray. Depending on your wall finish, consider utilising split lines between tiles to conceal the panel. See figure 16

WALL CLOSING AND FINISHING

1. Adjust screw head to finish inline with the finished wall. See figure 17
2. Use a drop of silicone to attach screw head to inside he fascia, which slides over the horizontal bars or mounting frame. See figure 18

Figure 17.

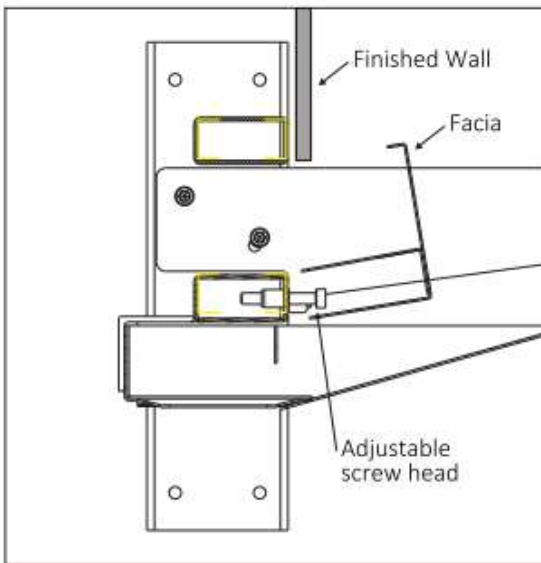
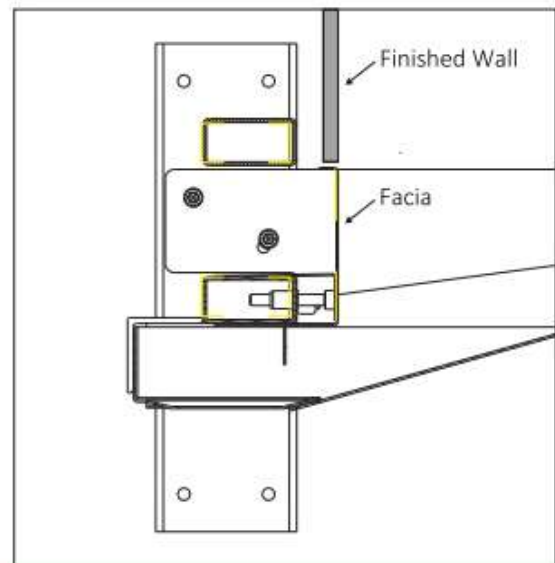

Figure 18.



FINISHED WALL TOP

It is imperative that the wall finish around the hardware (tile, stone, glass etc) is neat, leaving a minimal gap.

See figure 19

Figure 19.

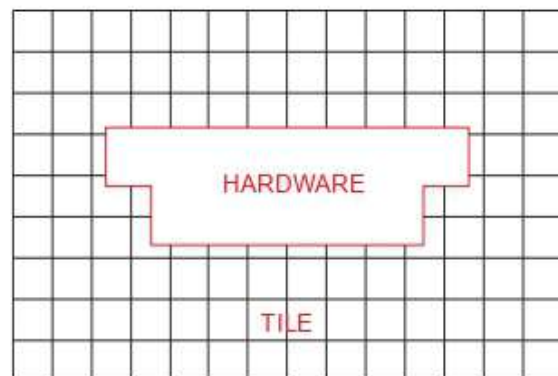



WASHPLANE CARE & MAINTENANCE

Regularly slide out the drainer to access the tray and waste area for cleaning and to ensure they are free of build up or blockages. A general not abrasive household cleaner can be used on stainless steel components.

Always start your cleaning routine with the basic clean and move to a deep clean if necessary.

Solid Surface Basin Basic Clean: Spills should be cleaned promptly. Clean with a mild detergent or soapy water and a soft, sponge or non-scratch scourer*1.

Solid Surface Deep Clean: For a deep clean and to remove cosmetics, ink and other colour agents that may leave marks on the surface use a diluted very mild abrasive cleaner* with a soft cloth in light circular motions. For stubborn marks or staining a light buff in circular motions using diluted very mild abrasive* cleaner with non-scratch scourer *1 will generally restore the finish.

Solid Surface Intense Clean/Repair: For extreme marks and light scratches a very light buff in circular motions using the fine grade sand/glass paper¹ will restore the surface. A heavier grade of sandpaper will scratch the surface, which can be removed by then using a light sand paper.

Natural Stone Clean: Natural stone is porous. It is important to clean any spills promptly. Clean with warm soapy water, or a mild non-abrasive, non-acidic, neutral PH7 cleaner with a soft cloth. Finish by cleaning off detergents with a sold wet cloth and towel dry.

As natural stone is a porous material and due to the abrasive nature of water and general use, your stone needs to be protected. You can care for your natural stone by applying GEAL sealant or another complimentary type approximately every 6 months or when required. Follow the instructions supplied with the sealant. All Omvivo productys manufactured in natural stone are supplied sealed with GEAL sealant.

Caesarstone® Clean: Caesarstone® is no porous, scratch and stain resistant. No sealants/waxes required therefore no ongoing maintenance needed. Always start your cleaning routine with the basin clean. Move to a deep clean if necessary.

Basic Clean: Wipe the surface with warm soapy water and a damp cloth or alternatively use a quality spray and wipe type cleaner.

Deep Clean: For stubborn stains or to give the surface a thorough clean, Caesarstone® recommend using Caesarstone® brand cream cleanser and a 3MTM Scotchbrite™ Never Scratch all-purpose non-scratch scourer which can be used without damaging the stone, or alternatively applied to a soft damp cloth. To remove adhered materials like food or nail polish, first scrape away the excess with a sharp blade. If there are any grey metal marks on the surface, a mild detergent will remove it.

Important notes:

For best results finish by wiping surface clean of all detergents and dry with a soft clean cloth.

Regular cleaning will assist to keep your solid surface and cabinetry looking fantastic and reduce wear and dirt build up.

For consistent appearance with your solid surface, it is best to give the entire surface of the product the same clean/sand. Avoid applying excessive pressure on clean/rub the same area for a prolonged period of time, unless repairing a scratch or damage.

Never use sharp products such as steel wool or aggressive, commercial grade / strong cleaners or chemicals (e.g. acetone, Trichloroethylene, acids and caustics soda) as these may damage and scratch the surface.

Only use your Washplane basin cleaning instructions on your Washplane as these cleaning methods may cause damage to other products, materials and finishes which will not be covered by your warranty.

* Always test "non-scratch" and "mild abrasive" products in a non-conspicuous area first to ensure suitability as brands can differ
1 Your basin has been supplied with a white non scratch scourer and a fine grade sanding pad.



WASHPLANE WARRANTY

Washplanes are covered by a

5 YEAR WARRANTY - DOMESTIC USE

This warranty covers faults in the product construction, material and assembly. Products which are within 5 years material or assembly, will be repaired or exchanged with an equivalent product free of charge.

LABOUR AND SPARE PARTS

A 12 month warranty over spare parts and labour will cover spare parts which are within 1 year from the date of assembly, will be replaced free of charge.

WARRANTY CONDITIONS

This warranty will apply only under all of the following conditions:

- The item has been installed by a licensed plumber.
- The item has been installed for and subjected to domestic residential use only.
- Failure is due to a fault in the manufacture of the product. Proof of purchase (including date of purchase) is provided.
- The installation of the product is in accordance with the instructions provided.

This warranty does not include faults caused by:

- Unsuitable or improper use.
- Water damage.
- Incorrect installation or installation that is not in accordance with the instructions provided.
- Installation or part installation by the purchaser or any person other than a LICENSED PLUMBER.
- Normal wear and tear.
- Inadequate or complete lack of maintenance.
- Chemical, electrochemical or electrical influences.
- Harsh detergents or abrasive cleaners used on product finishes.
- Failure of stone material. Stone is a natural material and as such Omvivo will not warrant against the failure of the natural stone.

PLEASE NOTE: The manufacturer will not be liable for the cost of installation or removal of any unit. The warranty will be voided if damage occurred during or after installation.

1 YEAR WARRANTY - COMMERCIAL USE

"Commercial" use is all use other than for normal domestic residential purposes, including use in non-business places as in public buildings, schools, sports centres and in establishments that contain private bathrooms with high frequency of use by many individuals such as hotels, motels, retirement villages and hospitals.

The commercial warranty covers this product against manufacturing faults in the construction, material and assembly of both the finished product and any spare parts for a period of 1 year from the date of purchase. Products and spare parts, which are found upon inspection by an authorized representative to be defective in construction, material or assembly will be repaired or exchanged free of charge. The warranty conditions and exclusions, which apply to the domestic use warranty, also apply to this commercial warranty.

EXCLUSIONS

To the fullest extent permitted by law, the manufacturer excludes all liability for damage or injury to any person, damage to any property and any indirect consequential or other loss or damage.

CLAIM PROCEDURE

For all warranty queries, customers are to contact the branch where the product was purchased. These details can be found on your purchase invoice.

Our goods come with guarantees that cannot be excluded under the Australian Consumer Law. You are entitled to a replacement or refund for a major failure and for compensation for any other reasonably foreseeable loss or damage. You are also entitled to have the goods repaired or replaced if the goods fail to be acceptable quality and the failure does not amount to a major failure.