

PARTS LIST

1. WALL BREACH 120MM
2. 35MM CARTRIDGE
3. DRESS PLATE
4. MIXER HANDLE
5. GRUB SCREW M5X6
6. O-RING
7. WALL SPOUT
8. MIXER DOME
9. WALL MIXER BODY
10. MIXER LOCKNUT
11. AERATOR
12. RUBBER PIN

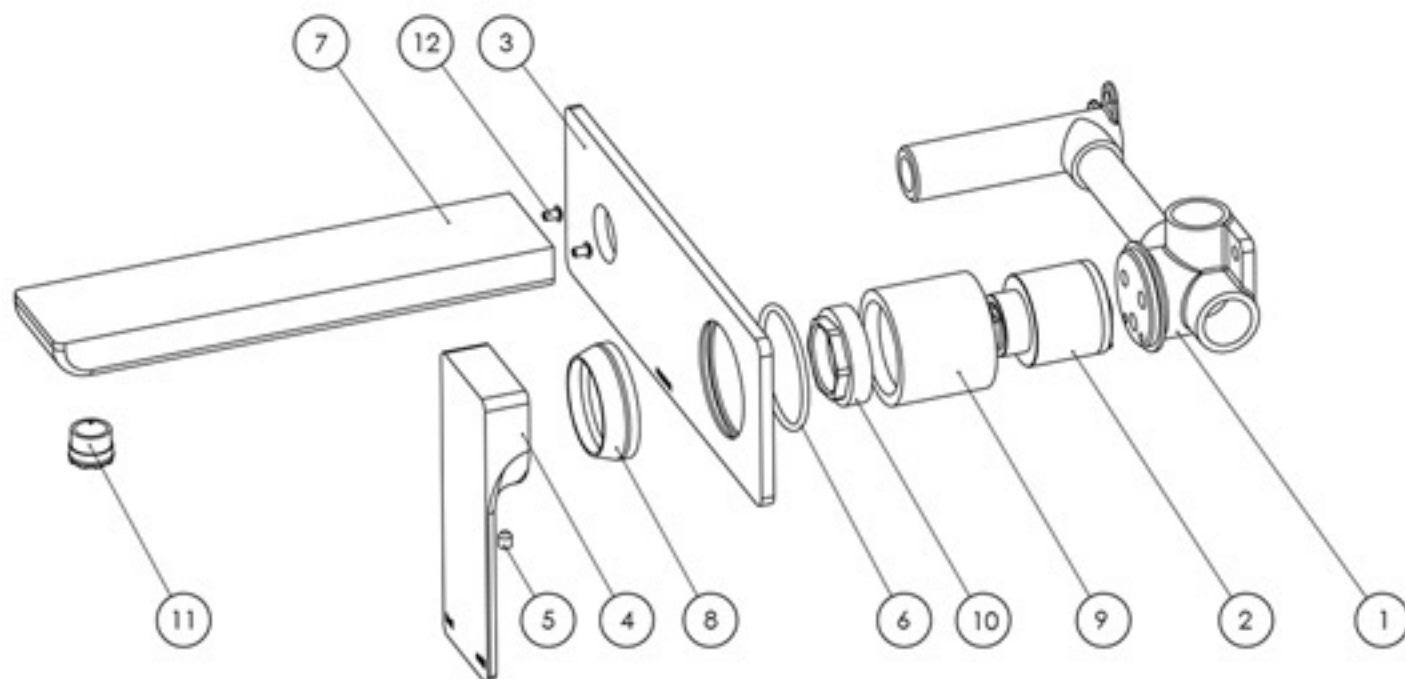

MAINTENANCE AND CARE:

- All surfaces should be cleaned with mild liquid detergent or soap and water.
- Do not use cream cleaners or citrus based cleaning products, as they are abrasive.
- Use of unsuitable cleaning agents may damage the surface. Any damage caused in this way will not be covered by warranty.