

PARTS LIST

1. GRUB SCREW M5X6
2. MIXER HANDLE
3. DRESS PLATE
4. O-RING 11X2.5MM
5. BREECH
6. 35MM CARTRIDGE
7. MIXER BODY
8. LOCKNUT
9. DOME
10. O-RING 6.6X1.0MM
11. O-RING 33X2.0MM
12. PIN LEVER

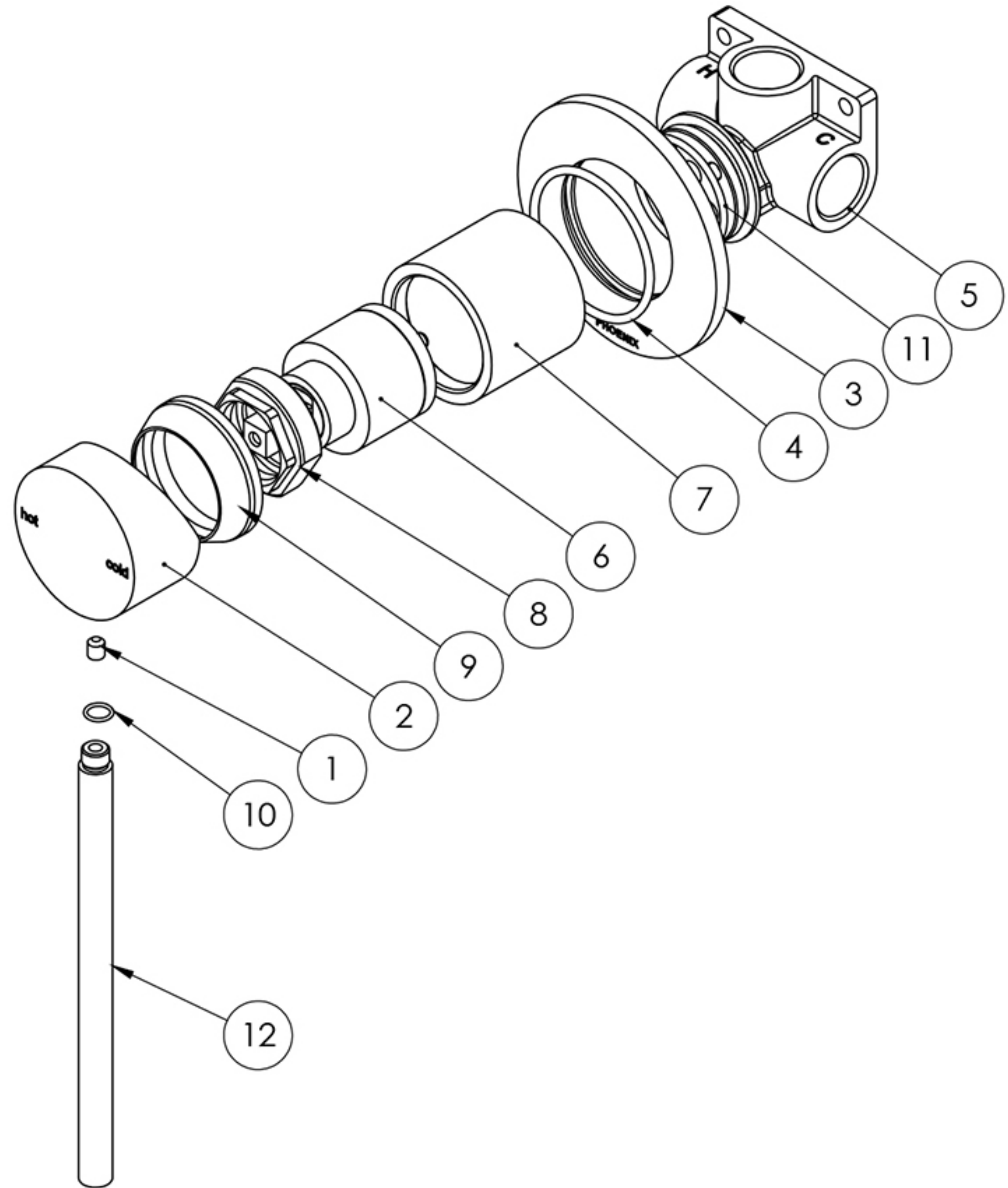

MAINTENANCE AND CARE:

- All surfaces should be cleaned with mild liquid detergent or soap and water.
- Do not use cream cleaners or citrus based cleaning products, as they are abrasive.
- Use of unsuitable cleaning agents may damage the surface. Any damage caused in this way will not be covered by warranty.