

BREACH SET-UP

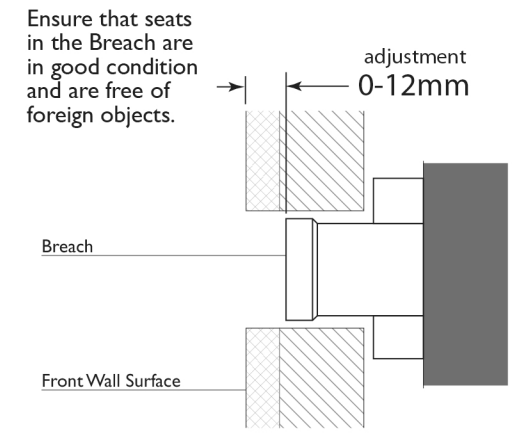

1

- Apply Teflon Tape to Threaded Elbow.
- Firmly screw the Swivel Flange onto Threaded Elbow.
- Seat the Small Bearing inside the Swivel Flange.
- Push Spout Tail into the Swivel Flange.
- Fasten Grub Screw until tight and then loosen a quarter turn.

NOTE
Ensure that the hole in the Large Bearing aligns with the grub screw hole:

2

Firmly screw Spindle into the Breach.

DO NOT OVERTIGHTEN

3

Fit Fibre Washer around the Spindle and then firmly fasten the Bonnet onto the Spindle using a spanner.

4

Fit O-Ring to the groove in the rear of the Flange.

Firmly fasten Flange onto the Spindle.

5

Fit Handle Hub to Spindle and fasten with the Grub Screw using the Allen Key provided.

Screw the Handle Pin into the Handle Hub

recommended working pressure
150-500 KPa

maximum hot water temperature
75 degrees