

NOTE
Check the rubber seal under each spindle:

HOT
← RED

COLD
← BLUE

BREACH SET-UP

- Ensure that seats in the Breach are in good condition and are free of foreign objects.
- The recommended installation range for the breach are as shown:
- Reseat if required.

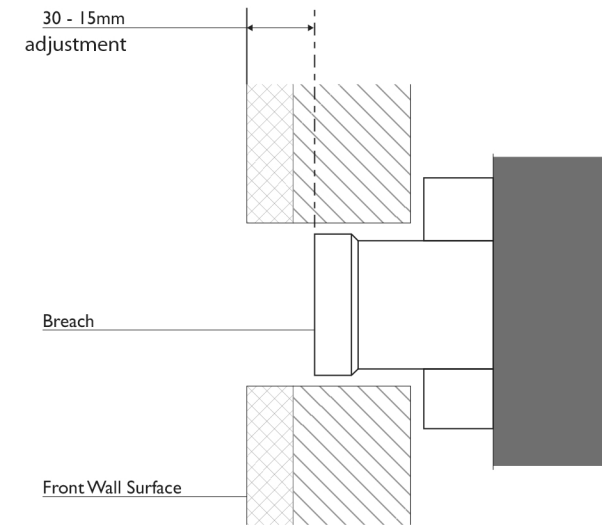

1

Firmly screw Spindle into the Breach.

DO NOT OVERTIGHTEN

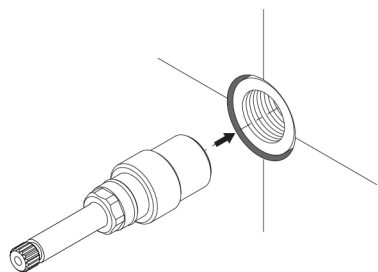

2

Fit Fibre Washer around the Spindle and then firmly fasten the Bonnet onto the Spindle using a spanner.

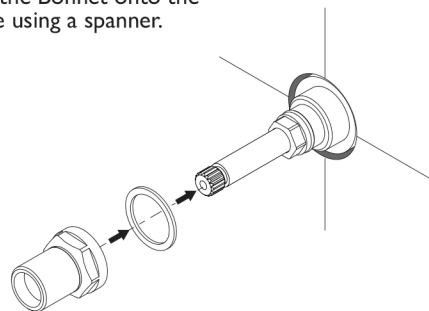

3

Fit O-Ring to the groove in the rear of the Flange.

Firmly fasten Flange onto the Spindle.

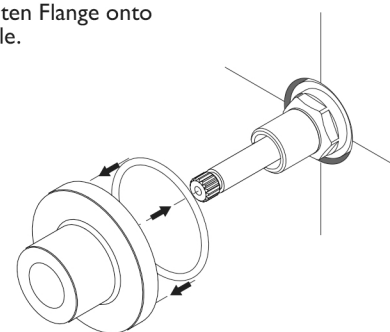

4

Fit Handle Hub to Spindle and fasten with the Grub Screw using the Allen Key provided.

Screw the Handle Pin into the Handle Hub

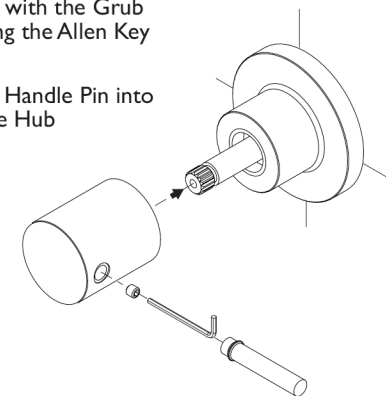

recommended working pressure
150-500 KPa

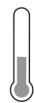

maximum hot water temperature
75 degrees