

## SPECIFICATIONS

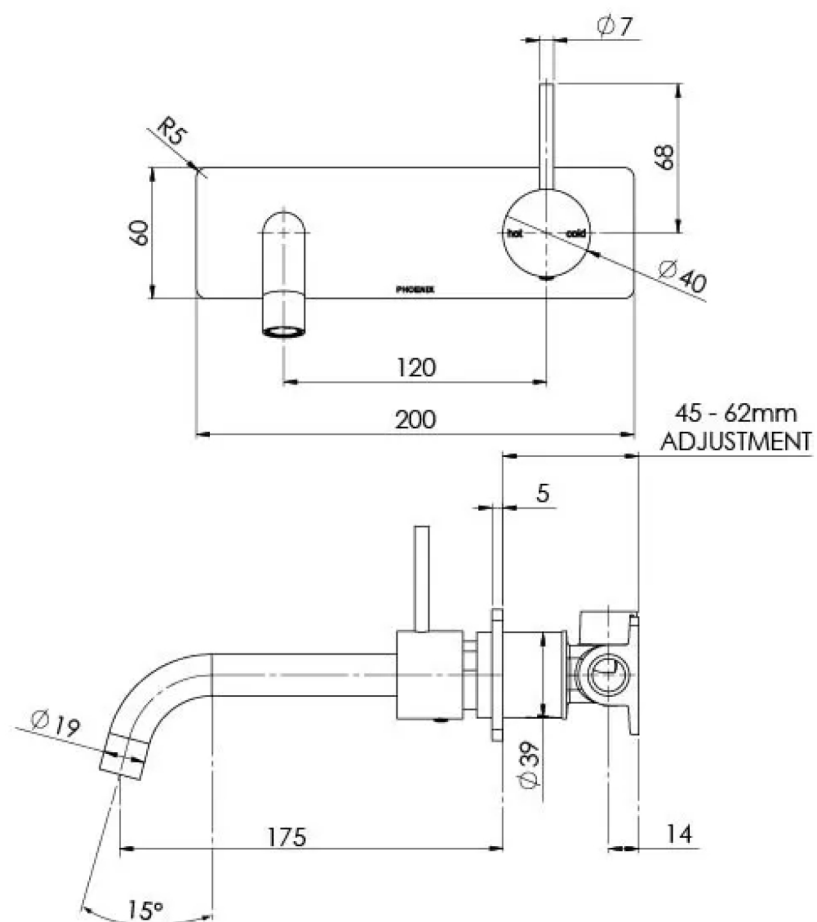

### AVAILABLE IN



112-7813-00  
Chrome



112-7813-40  
Brushed Nickel



112-7813-30  
Gun Metal



112-7813-31  
Brushed Carbon



112-7813-10  
Matte Black



112-7813-12  
Brushed Gold

### INFORMATION

Temperature Rating  
1 - 75°C

Pressure Rating  
150 - 500kPa

### MAINTENANCE AND CARE:

- All surfaces should be cleaned with mild liquid detergent or soap and water.
- Do not use cream cleaners or citrus based cleaning products, as they are abrasive.
- Use of unsuitable cleaning agents may damage the surface.
- Any damage caused in this way will not be covered by warranty.