

1

Screw the Mixer Breach onto Noggin.
Ensure that the Outlet and Mixer Body centres are level.

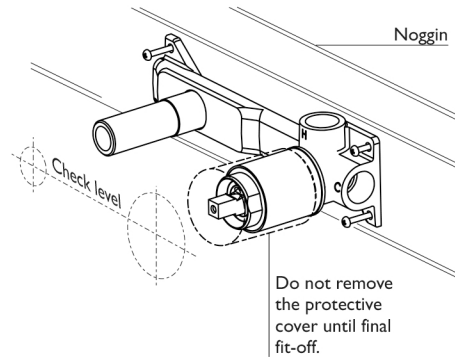

2

Connect hot and cold water supply, as shown.
Test and check for leaks.

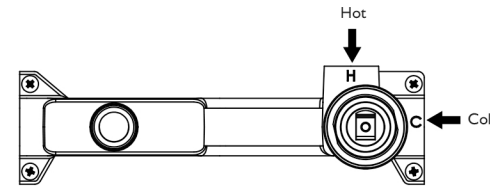

3

Check centre distance of the breach assembly for 120mm or 140mm size.
Mark centre line according to measured result.
Create a 25mm hole and a 45mm hole on the cement sheet and tiles, as shown.

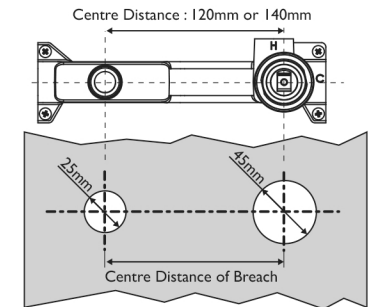

4

Remove the protective cover from the mixer.
Apply Teflon tape to Elbow Thread.
Gently push the dress plate into position.

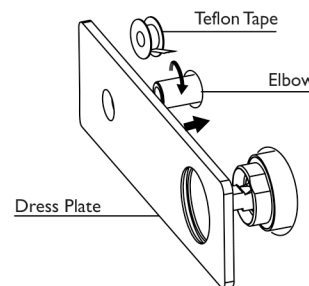

5

Screw Wall Outlet to the Elbow Thread until firmly tightened and the outlet hole is facing down.
Fit Mixer Handle into position and tighten Grub Screw to secure handle.
Fit Screw Cap into position.

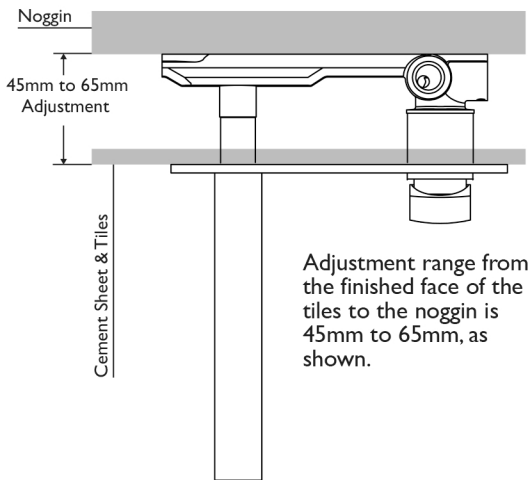
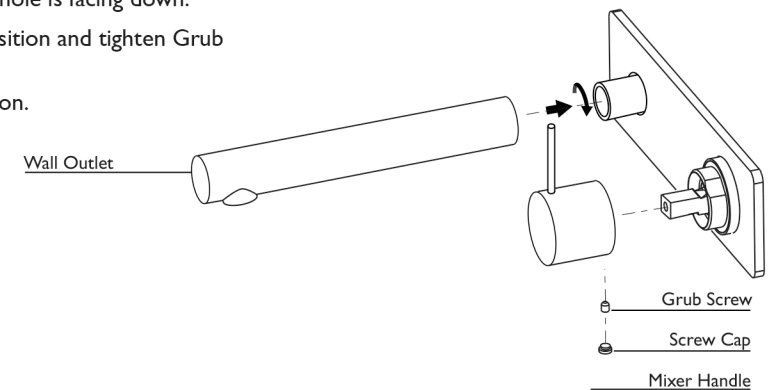

Adjustment range from the finished face of the tiles to the noggin is 45mm to 65mm, as shown.



recommended working pressure

150-500 KPa

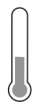

maximum hot water temperature

75 degrees