

NOTE

Before drilling through the bench surface, check that there is a clear area directly underneath for the sprayer hose to retract. Allow 750mm for normal operation.

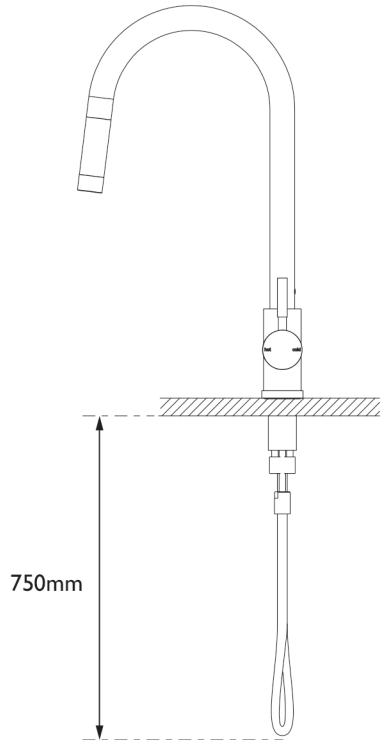

1

Using a 38mm hole saw, cut a neat hole through the bench top.

Remove the Lock Nut, Spacer, and the Sprayer Hose from the mixer Hose Outlet. Feed the Sprayer Hose through the hole and then position the mixer over the hole.

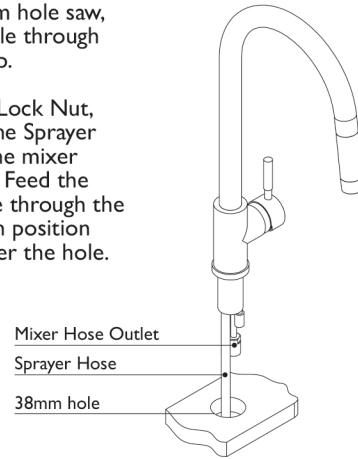

2

Slide the plastic Spacer and Lock Nut over the Sprayer Hose and then over the mixer threaded tail. Tighten the lock nut firmly against the spacer. For additional security, screw the jamming screws into the spacer firmly.

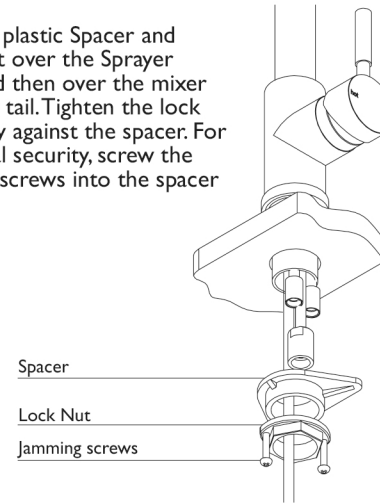

3

Attach the Counter Weight to the Sprayer Hose with the two screws supplied. Adjust the Counter Weight to approximately 200mm from the bottom of the Sprayer Hose.

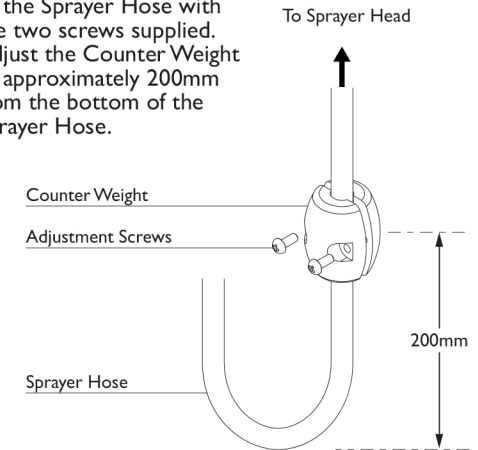

4

Apply Teflon Tape to Sprayer Hose Fitting.

Connect the Sprayer Hose fitting to the Mixer Hose Outlet

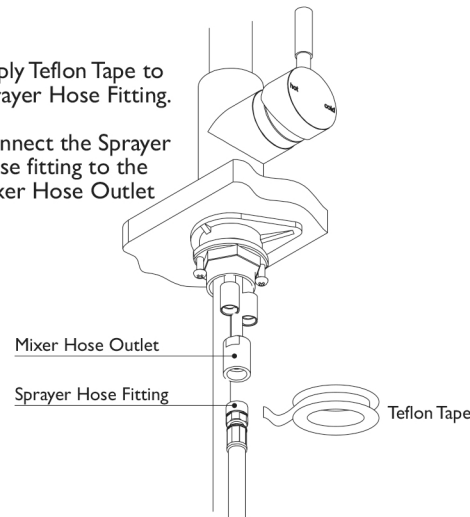

5

Connect Hoses to the Mixer Inlets. Ensure that the Red Marked Hot Water Hose is connected to the inlet that is marked with Red Indicator Tape.

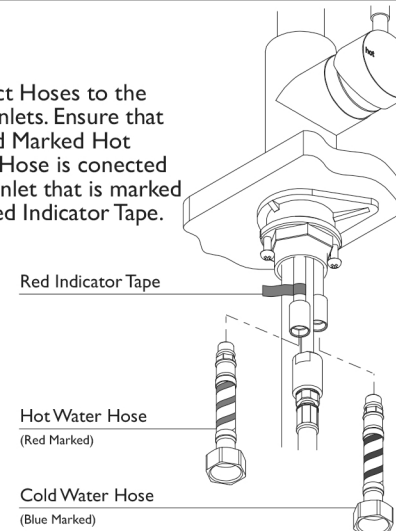

6

Connect Hoses to water supply.
CHECK AND TEST FOR LEAKS

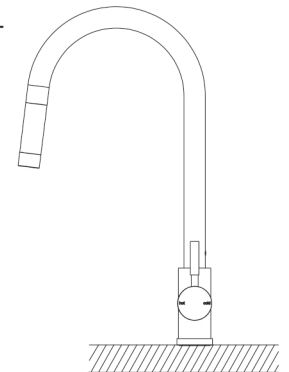

recommended working pressure
150-500 KPa

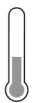

maximum hot water temperature
75 degrees