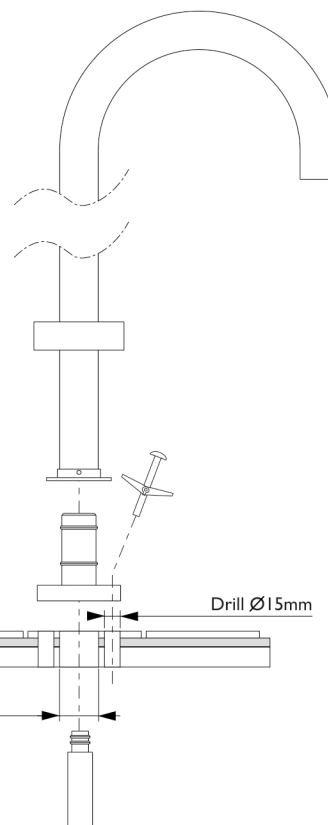
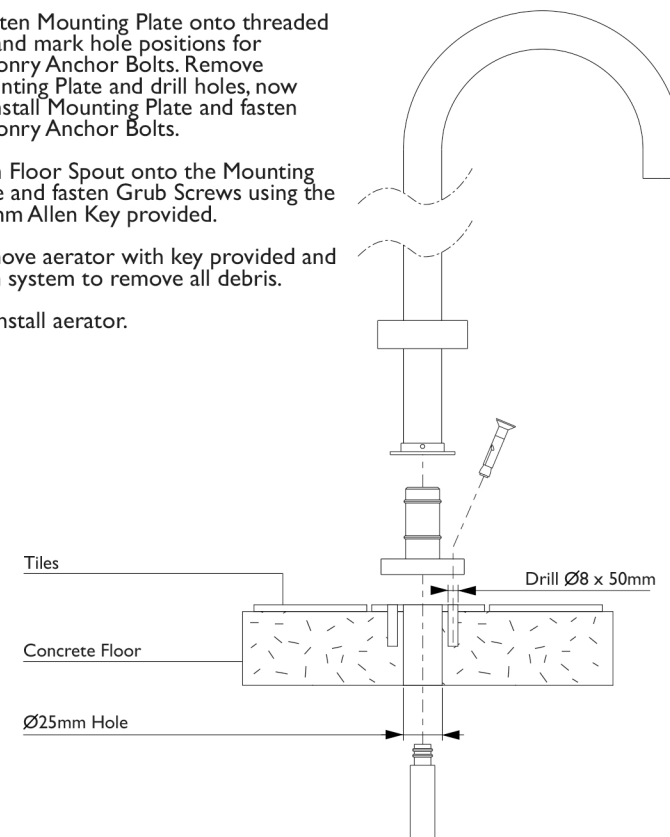
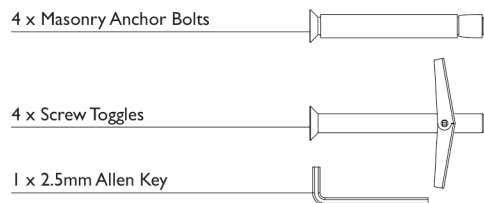

WOOD FLOOR INSTALLATION

1. Drill a 25mm hole in the required position through the floor.
2. Connect G 1/2" Threaded Tail to water supply and ensure tail protrudes above the floor between 21mm and 28mm.
3. Tighten Mounting Plate onto threaded tail and mark hole positions for Screw Toggles. Remove Mounting Plate and drill holes, now re-install Mounting Plate and fasten using the Screw Toggles provided.
4. Push Floor Spout onto the Mounting Plate and fasten Grub Screws using the 2.5mm Allen Key.
5. Remove aerator with key provided and flush system to remove all debris.
6. Re-install aerator.

CONCRETE FLOOR INSTALLATION

1. Drill a 25mm hole in the required position through the floor.
2. Connect G 1/2" Threaded Tail to water supply and ensure tail protrudes above the floor between 21mm and 28mm.
3. Tighten Mounting Plate onto threaded tail and mark hole positions for Masonry Anchor Bolts. Remove Mounting Plate and drill holes, now re-install Mounting Plate and fasten Masonry Anchor Bolts.
4. Push Floor Spout onto the Mounting Plate and fasten Grub Screws using the 2.5mm Allen Key.
5. Remove aerator with key provided and flush system to remove all debris.
6. Re-install aerator.

MOUNTING KIT

recommended working pressure

150-500 KPa

maximum hot water temperature

75 degrees
