

NOTE: This is a floating breach assembly. The breach will move forward when fully tightened against the Mounting Plate. This ensures the Dress Plate is parallel with the tiled surface.

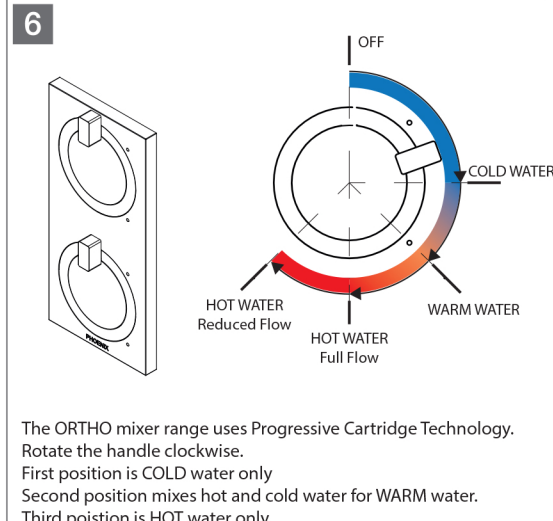
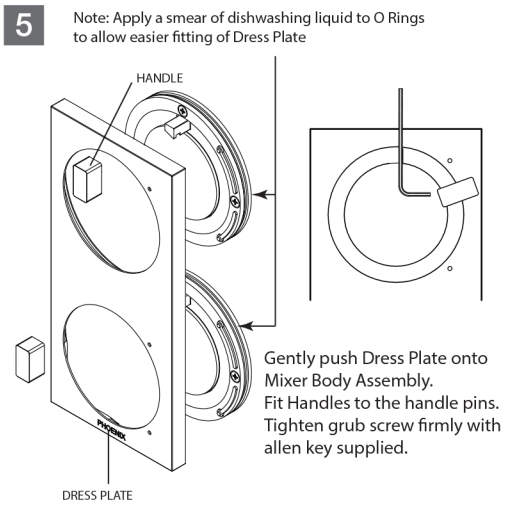
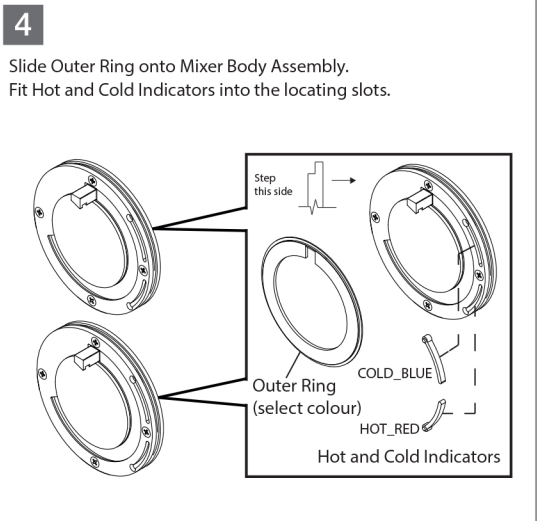
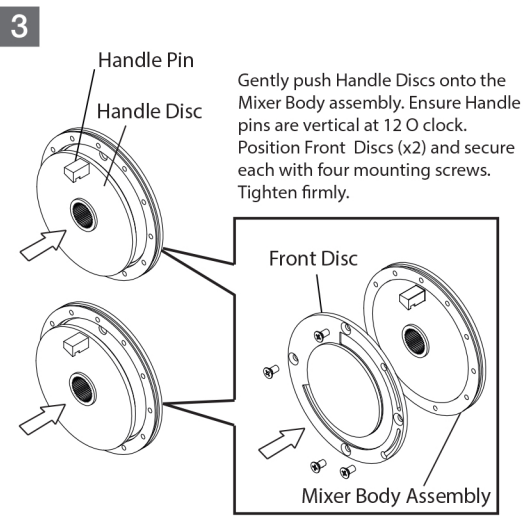
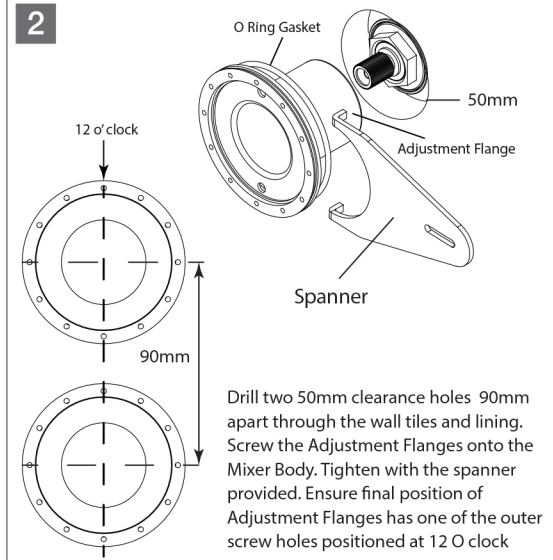
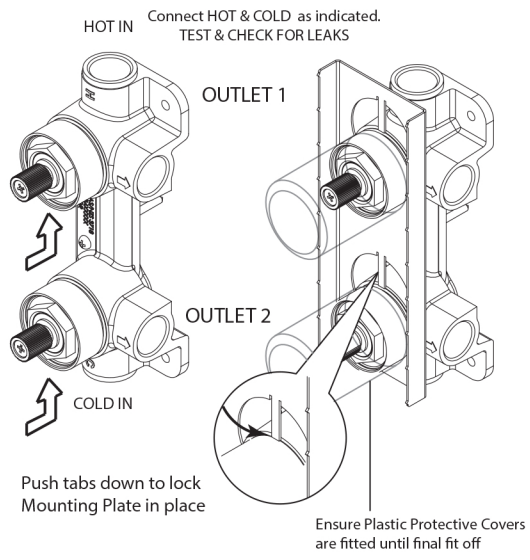
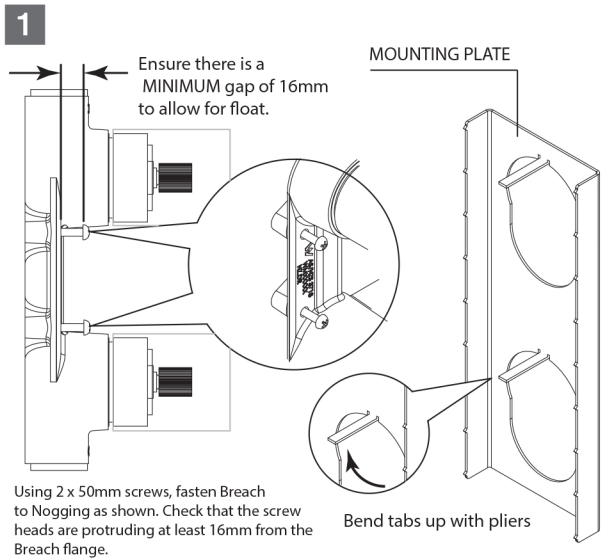
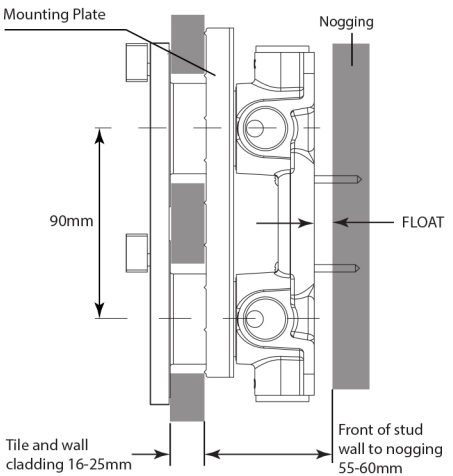

recommended working pressure

150-500 KPa

maximum hot water temperature

75 degrees

