

EXPLODED

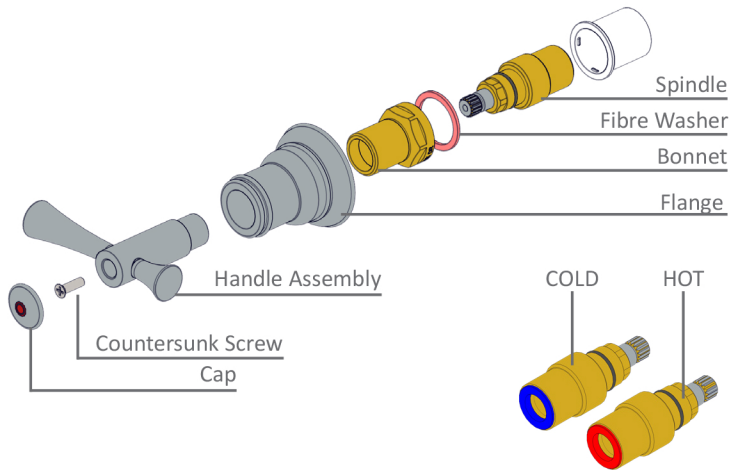

ADJUSTMENT RANGE

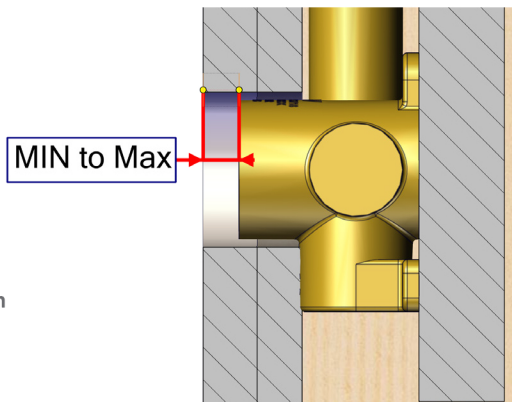

134-0600 - Wall Top Assembly:
Min: 0mm
Max: 15mm

134-0670 - Wall Top Assembly Ext'd 15mm:
Min: 15mm
Max: 30mm

1

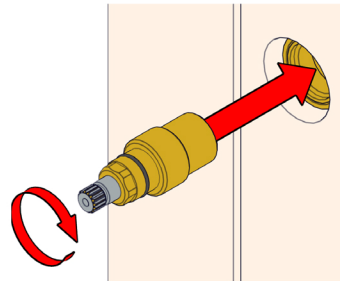

Screw Cartridge Body into recess till Cartridge Seat meets a physical stop.

Do not over tighten.

2

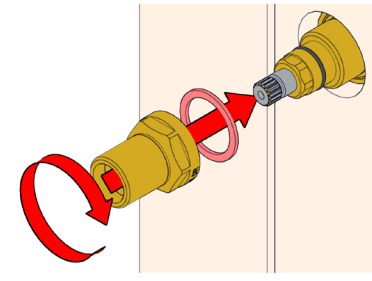

Fit Fibre Washer around the Spindle and then firmly fasten the Bonnet onto the Spindle using a spanner.

3

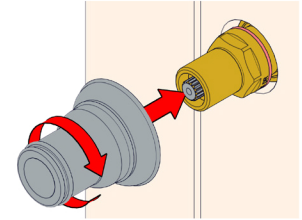

Screw Flange to the Bonnet until flush with wall.

4

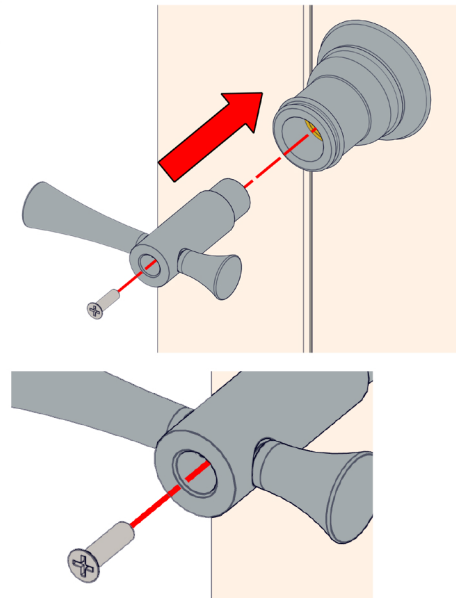

Fit Handle Assembly over spline. Ensuring Handles are level.

Fix to cartridge using supplied countersunk screws.

5

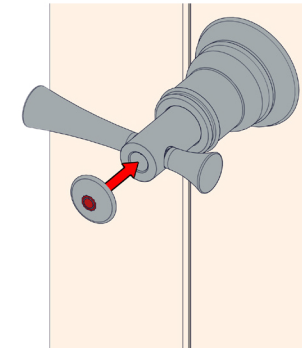

Push temperature indicator caps onto handles as shown.



recommended working pressure

150-500KPa

maximum hot water temperature

75 degrees