

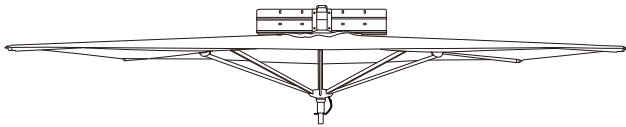

WALLMOUNT
1.5M X 3M
Cantilever
Assembly and Operation Guide



Please remove all contents from the package, inspect and review checklist.
CAUTION: To reduce personal injury and damage to your umbrella, read and follow this assembly and operation guide. We recommend a two-person team for assembly and disassembly. *Save information for future reference. We suggest consulting a licensed contractor for proper mounting.*

CHECKLIST

- | | |
|--|--------------------------------------|
| A - Mounting Track | G - Lock Block with (2) Set Screws |
| B - Screw Anchors and Washers (4) - 3/8" x 3" (not included) | H - Protective Cover |
| C - Lag Bolts and Washers (4) - 3/8" x 3" (not included) | I - Protective Cover Lock Blocks (2) |
| D - Umbrella | J - Tapping Screws (4) |
| E - Hinge | K - Allen Wrench - 4mm |
| F - Hinge Screw and Locknut | L - Allen Wrench - 6mm |

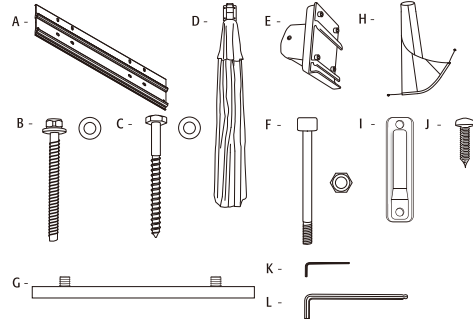

IMPORTANT:

- Prior to assembly it is important to decide on the location of the umbrella.
- Allow ample height to avoid damage to your umbrella during assembly and usage.
- Storage:
- Properly store umbrella when not in use. Close umbrella, tie string around canopy, cover umbrella with provided protective cover and tie cover handles to protective cover lock blocks. Or remove structure from mounting track and properly store structure.
- NOTE:** Some parts may be included in the styrofoam packaging. DO NOT discard any packaging or box until assembly is complete.

MOUNTING TRACK

Mounting on wood frame walls wood, vinyl, stucco or aluminum siding, proceed below.
Mounting on masonry, brick or concrete walls, proceed to page 4.

Mounting on wood frame walls with wood, vinyl, stucco or aluminum sliding:

STEP 1 Locate Studs

Locate studs in the area which the track will be installed.

STEP 2 Position Track

Position track level on wall at desired height and location. Allow ample height and width to avoid damage to your umbrella during assembly and operation. Place bolt holes at center of studs and mark. If holes in track do not line up with existing structural supports, new holes can be drilled into the track to accommodate lag bolts.

STEP 3 Drill Holes

Remove track and drill 1/4" holes into the wall about 75mm into the studs. This will prevent frame from splitting while installing the lag bolts. **NOTE:** Shims or spacers may need to be added on angled siding. Silicone cocking may be added to the holes before bolts are installed to prevent water from penetrating wall.

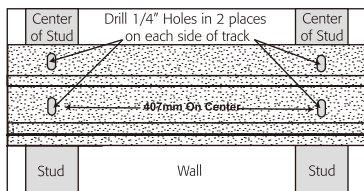

STEP 4 Install Track

Using a 9/16" socket, install the track with the four 3/8" x 75mm lag bolts and washers (not included). While tightening the lag bolts, keep the track level. Do not overtighten the lag bolts; doing so may split the wood frame or weaken the lag bolt. **Consult a licensed contractor for bolts that fit these types of applications.**

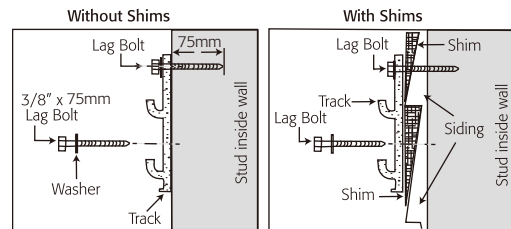

NOTE: For vinyl or aluminum siding, shimming beneath the siding under the track may provide a more solid surface for mounting.

CAUTION: It is critical that you fasten two lag bolts at each end of the track to studs, header or other major structural members in the wall. **Consult a licensed contractor for bolts that fit these types of applications.**

WARNING: Failure to properly fasten mounting track to wall could result the umbrella to collapse causing property damage and/or personal injury. **We suggest consulting a licensed contractor for proper mounting.**

Mounting on masonry, brick or concrete walls:

STEP 1 Position Track

Position track level on wall at desired height and location. Mark bolt holes on concrete or main body of brick. If holes in track do not line up with existing structural supports, new holes can be drilled into the track to accommodate screw anchors.

STEP 2 Drill Holes

Remove track and drill 1/4" holes into wall about 75mm deep and remove any loose concrete inside hole. Do not allow the holes to become tapered or oversized while drilling. Silicone cocking may be added to the holes before or after anchors are installed to prevent water from penetrating wall.

STEP 3 Install Track

Using a 9/16" socket, install the track with the (4) 3/8" x 3 screw anchors and washers (not included). While tightening the screw anchors, keep the track level. **Consult a licensed contractor for bolts that fit these types of applications.**

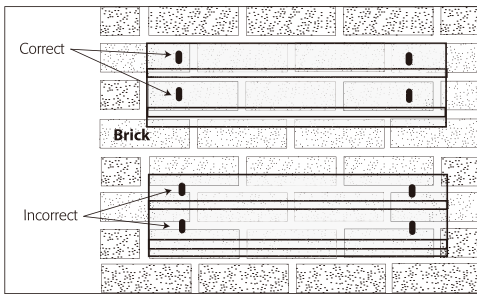

4

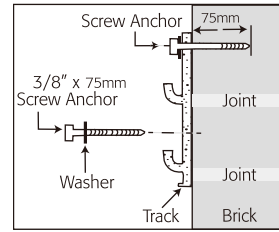

CAUTION: Screw anchors are not designed for use in the joints between two bricks. They are ONLY to be installed within main body of a brick and not within 50mm of an outer edge of the brick. The screw anchors are also not suited for hollow cinder block type construction or wall surfaces that have deteriorated. **Consult a licensed contractor for bolts that fit these types of applications.**

WARNING: Some brick walls may not be strong enough to safely support a Veranda umbrella. Screw Anchors are not designed to attach to veneer brick wall or soft bricks. We suggest consulting a licensed contractor for proper mounting.

WARNING: Failure to properly fasten mounting track to wall could result in the umbrella to collapse causing property damage and/or personal injury.

5

INSTALLING WALLMOUNT UMBRELLA

STEP 1 Attach Hinge to Wallmount Umbrella

Attach hinge to Wallmount Umbrella main frame with the track side facing outward. Secure together using supplied (1) hinge screw and (1) locknut. Note: Hinge screw only inserts one way. Tighten locknut with supplied 6r

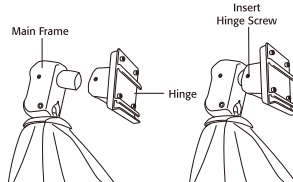

STEP 2 Attach Wallmount Umbrella to Mounted Track

Carefully lift and clip Wallmount Umbrella into mounted track on wall to your desired location. Note: Hinge will only clip onto track one way. Remove set screws from lock block. Slide lock block into bottom on hinge until flush. Insert set screws through bottom of hinge into lock block. Tighten set screws with supplied 4mm allen wrench to secure into place. NOTE: Do not over tighten set screws.

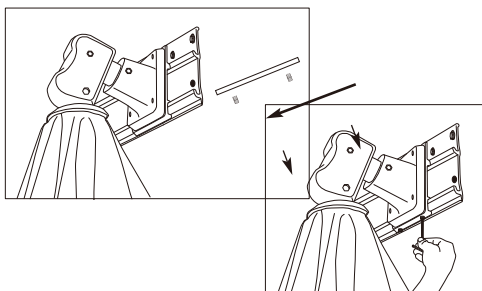
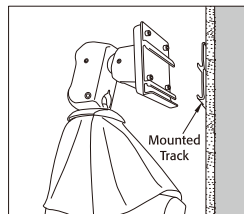

6

STEP 3 Open Wallmount Umbrella

Gently pull ribs slightly outward, while grabbing hub. Push hub upward, through center pole until hub locks into place. Slide pin into hub for extra support.

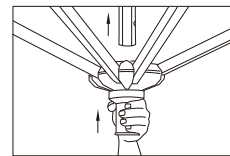

STEP 4 Close Wallmount Umbrella

Remove pin from hub. Pull on hub to unlock from center pole and guide hub down until umbrella is fully closed. Tie canopy with supplied string to secure.

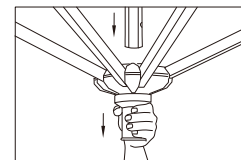

STEP 5 Adjust Position

While in closed position, loosen hexagon set screws on hinge and adjust frame position by sliding hinge left or right on mounting track to desired location. To secure, tighten set screws.

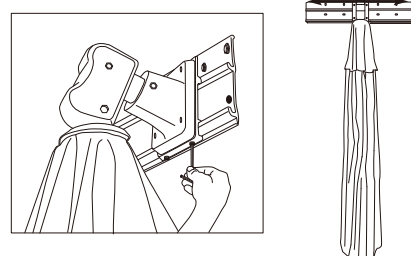

7

STEP 6 Protective Cover and Lock Block Assembly

Install (2) protective cover lock blocks with (4) supplied tapping screws onto wall. Tie canopy string around canopy to secure canopy. Slide protective cover over canopy using inserted rod as a guide. Pull down on zipper pole to close protective cover. Secure with (2) protective cover handles to lock blocks installed on wall.

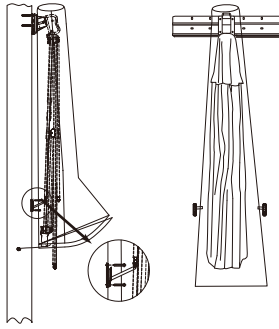

Features

To Attach Umbrella Light: (sold separately)

Open the umbrella light by holding firmly with one hand and then depress the clamp release button with the other hand to release the clamp lock. Open up the light and clasp around the light adapter post. Snap to close. **NOTE:** It is not necessary to remove light to close umbrella.

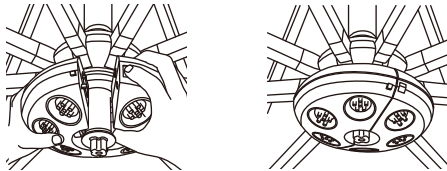

8

Safety Precautions :

- Close the umbrella in windy conditions or when a storm approaches. Never allow the umbrella to flap in the wind; this could damage the canopy.
- Properly store umbrella when not in use. Close umbrella, tie string around canopy and cover umbrella with provided protective cover.
- Do not leave open umbrella unattended. If damage occurs, this is not covered by the warranty.
- When adjusting the umbrella, make sure that no person(s) or item(s) are close to the umbrella. This is important to prevent injury or material damage.

Care And Maintenance :

- When not in use, close and cover umbrella with a protective cover.
- If necessary, clean the fabric with lukewarm water, mild detergent, and a sponge.
- Allow a wet canopy to dry slightly opened, but do not leave unattended.
- Wipe sliding marks on the aluminum poles with a damp cloth.

Winter Storage:

- Store in a dry place.
- Any visible defects must be repaired by a professional.

After the Winter:

- Areas subject to turning and sliding can be treated with a non-staining lubricant spray (silicone-based).
- Check the condition and function of the umbrella. Any defects must be repaired by a professional.

9

Warranty

Shelta warrants the frame of this product against manufacturer's faults for a period of 1 year from the date of purchase. Shelta repairs or replaces at our option.
Warranty does not cover:

- Damage caused by inadequate installation or inappropriate use
- Wind or other accidental damage
- Damage to fabric cover
- Normal wear and tear
- Commercial use
- Transport costs

Leaving the umbrella open in windy conditions voids the warranty.

Additional Information about this Warranty

In all cases the Shelta Warranty excludes normal wear and tear, wind damage, commercial use, use of unreasonable force, failure of reasonable care, failure of maintenance (as set out in detail below for each product), and incorrect assembly by the customer. The Shelta Warranty applies only to the original purchaser from the purchase date, and only covers (subject to the terms set out below) manufacturing faults or defects which occur in normal domestic use. Where a claim is made pursuant to the Shelta Warranty Shelta Australia will, at their discretion repair, refinish, replace, replace with a similar product or refund the product. Only the failed item will be replaced, not a complete setting. The Shelta Warranty period is not extended in the event of a replacement. In the event of a refund, it will be for wholesale price only. The balance of the retail price will be the responsibility of the retailer. In the event of a Shelta Warranty claim, please return the item to the store where purchased, with the original tax invoice. If the retailer cannot accept return of the product, please return to Shelta Australia at the address below. For residents outside Sydney, phone Shelta at the number below. Where the item is returned to Shelta Australia the purchaser must include the original tax invoice. The purchaser must also bear all costs associated with shipping the product to Shelta Australia and the return freight. The purchaser must also provide details of the problem with the product (such details must be sufficient for Shelta Australia to determine whether the Shelta Warranty applies).

Consumer Guarantees

Our goods come with guarantees that cannot be excluded under the Australian Consumer Law. You are entitled to a replacement or refund for a major failure and compensation for any other reasonably foreseeable loss or damage. You are also entitled to have the goods repaired or replaced if the goods fail to be of acceptable quality and the failure does not amount to a major failure. Such guarantees may include the right to a remedy from Shelta Australia if our products are not of an acceptable quality or do not match any demonstration model or sample (as those terms are defined in the Competition and Consumer Act 2010 (CCA)). Shelta Australia will not be liable for any act, default, omission or representation made by any person other than our employees, alterations made to the product not performed by us, damage or defects due to unusual or non-recommended use, or damage or loss caused by any factors beyond our control. Shelta Australia's total liability in respect of a claim by a consumer under the CCA for a minor problem (as defined in the CCA) with a product is limited, at our option to, providing the consumer with a refund, replacement product or repairing the product. Subject to the above paragraphs, all express or implied representations, conditions, statutory guarantees, warranties and provisions (whether based on statute, common law or otherwise), relating to this warranty, that are not contained in it, are excluded to the fullest extent permitted by law. Nothing in this warranty excludes, restricts or modifies any condition, warranty, statutory guarantee, right or remedy, implied or imposed by common law, statute or regulation, which cannot be lawfully excluded, restricted or modified.

Made in China