

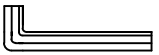





Model No : Lincoln Chair

ASSEMBLY INSTRUCTIONS

A	 M4 x 110mm ALLEN KEY.	1 pc
B	 M6 x 50mm JCBC BOLT	8 pcs
C	 M6 x 40mm JCBC BOLT	4 pcs
D	 Screw M4 x 32mm	10 pcs
E	 Wood Dowel 8 x 30mm	6 pcs
F	 Wood Button 15 x 9mm	12 pcs

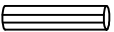

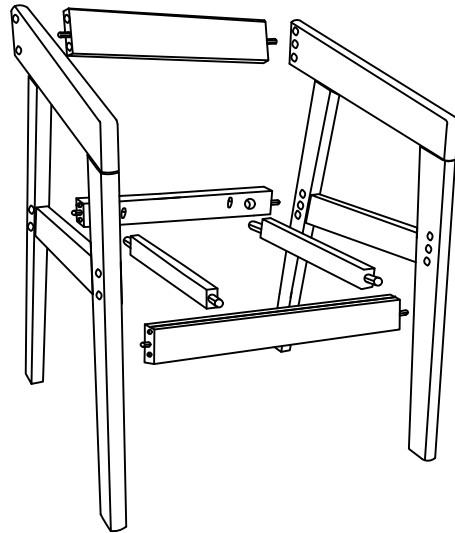
Step 1: Join the rails(shorter rail at back;longer rail at front)with two center supports.Screw with hardware D and turn it upside down for next step (screw side on bottom).

X 4

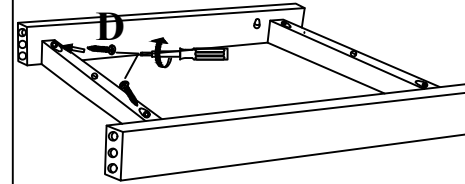

This is the bottom facing of the chair

Step 2

Chair Frame L

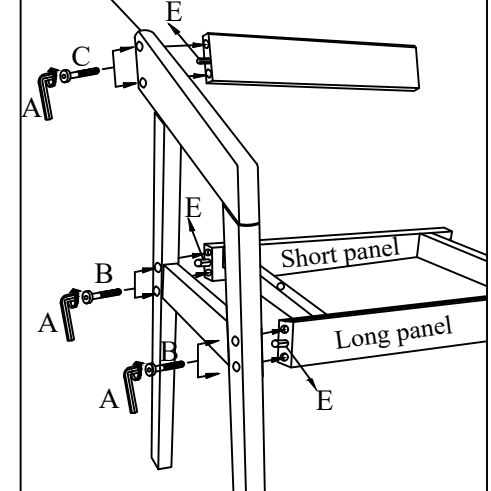

Step 3

Chair Frame R

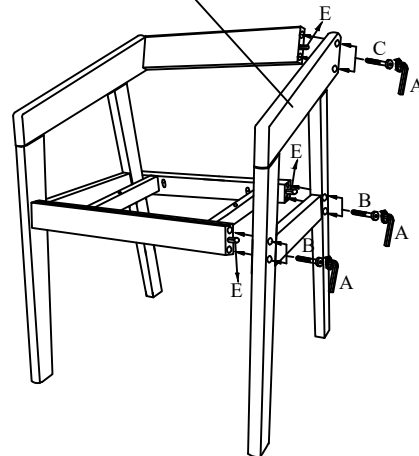

Step 4

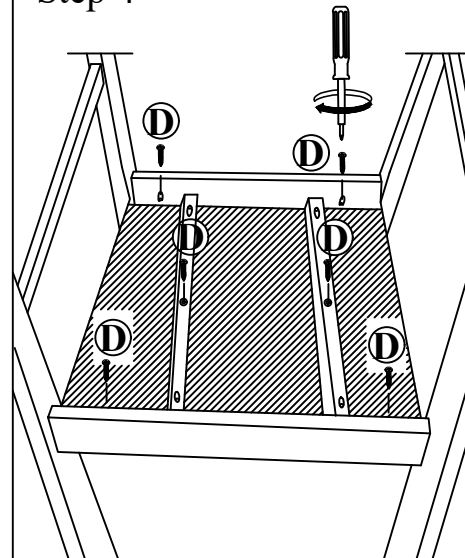

Step 5

