











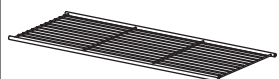
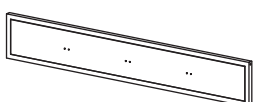
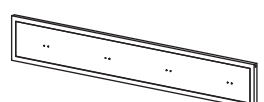
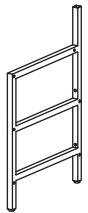
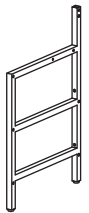

Assembly Instructions

HALL TREE











ATTENTION:

1. THE EXTRA SCREWS OF A/B/C/D/E/F HAVE BEEN PROVIDED IN CASE OF ANY SCREWS MISSING IN BOX.
2. MAKE SURE ALL PARTS ARE INCLUDED PRIOR TO ASSEMBLY.
3. TWO OR MORE PEOPLE HIGHLY RECOMMENDED FOR ASSEMBLY.

PART LIST

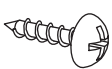
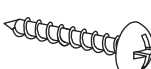
					
39.37"x15.16"	37.64"x15.75"				
① x 1PC	② x 1PC	③ x 1PC	④ x 1PC	⑤ x 1PC	
					
⑥ x 1PC	⑦ x 1PC	⑧ x 4PCS	⑨ x 1PC	⑩ x 1PC	
					
⑪ x 1PC	⑫ x 2PCS	⑬ x 2PCS	⑭ x 2PCS	⑮ x 2PCS	⑯ x 7PCS

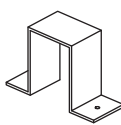
HARDWARE

					
M6x12mm	M6x15mm	M6x20mm	M6x30mm	M6x40mm	M6
Ax14PCS	Bx1PC	Cx1PC	Dx12PCS	Ex22PCS	Fx5PCS
					
4.0x14mm	4.0x35mm				ALLEN KEY
Gx14PCS	Hx4PCS	I x4PCS	Jx2PCS	Kx1PC	Lx1PC

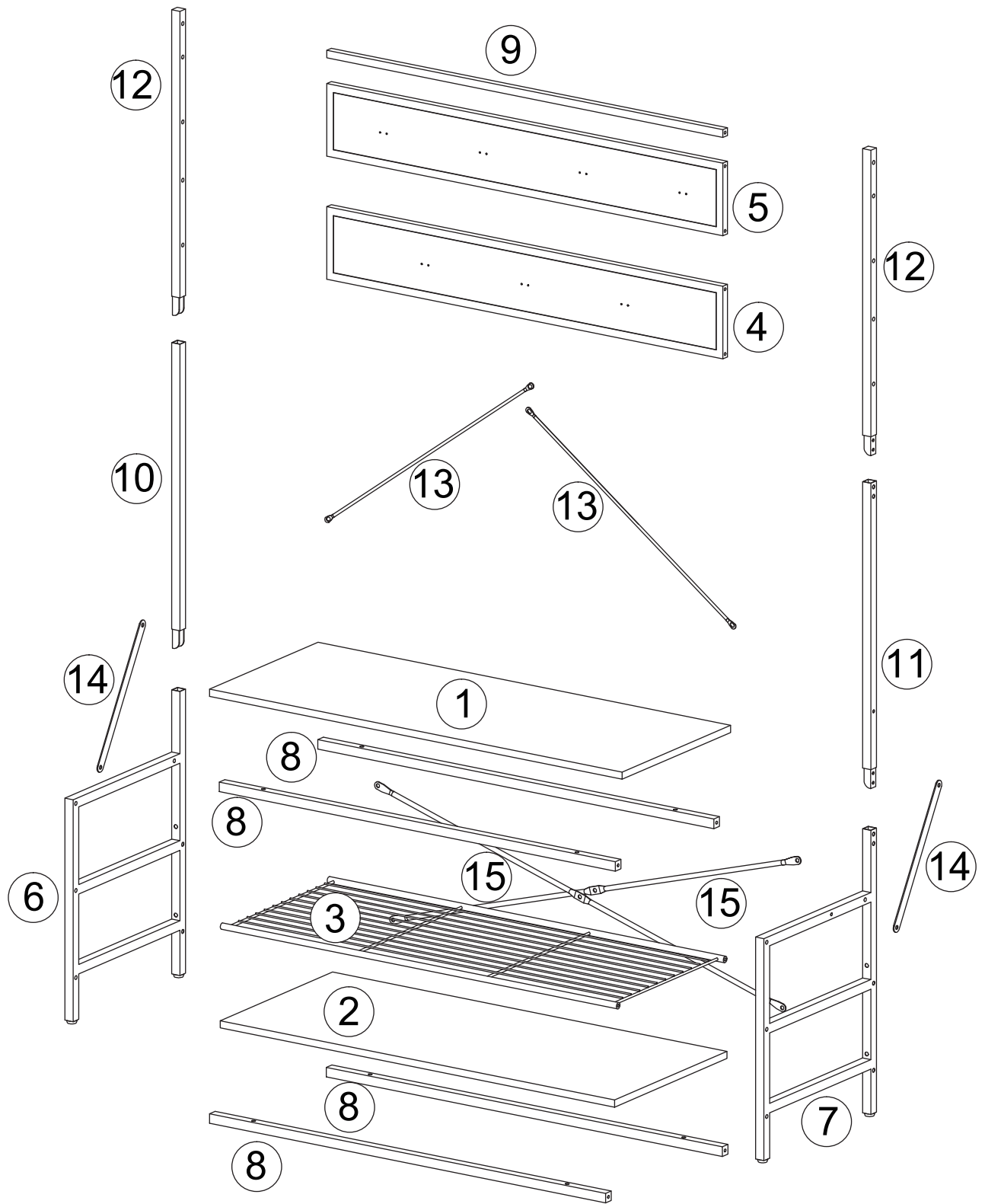

Before Assembly

① Classifying the screws base on the size.

! Don't Mix

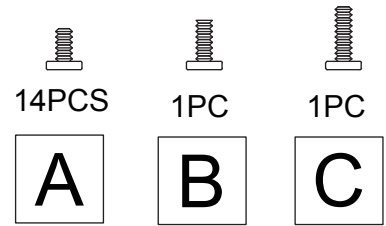
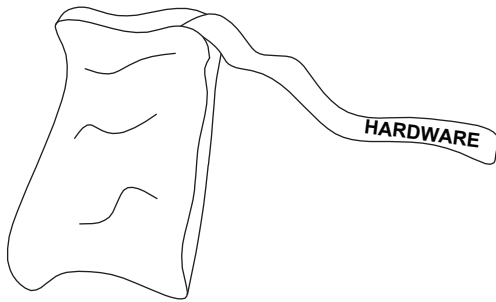

② Cut off the label and put it right here.

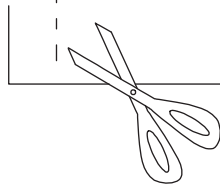
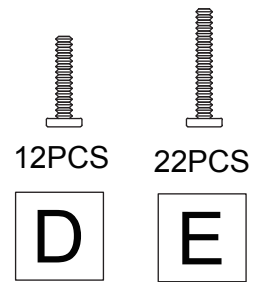
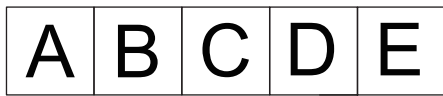

! If you fail to distinguish the screw size, you can measure them on the following size chart.

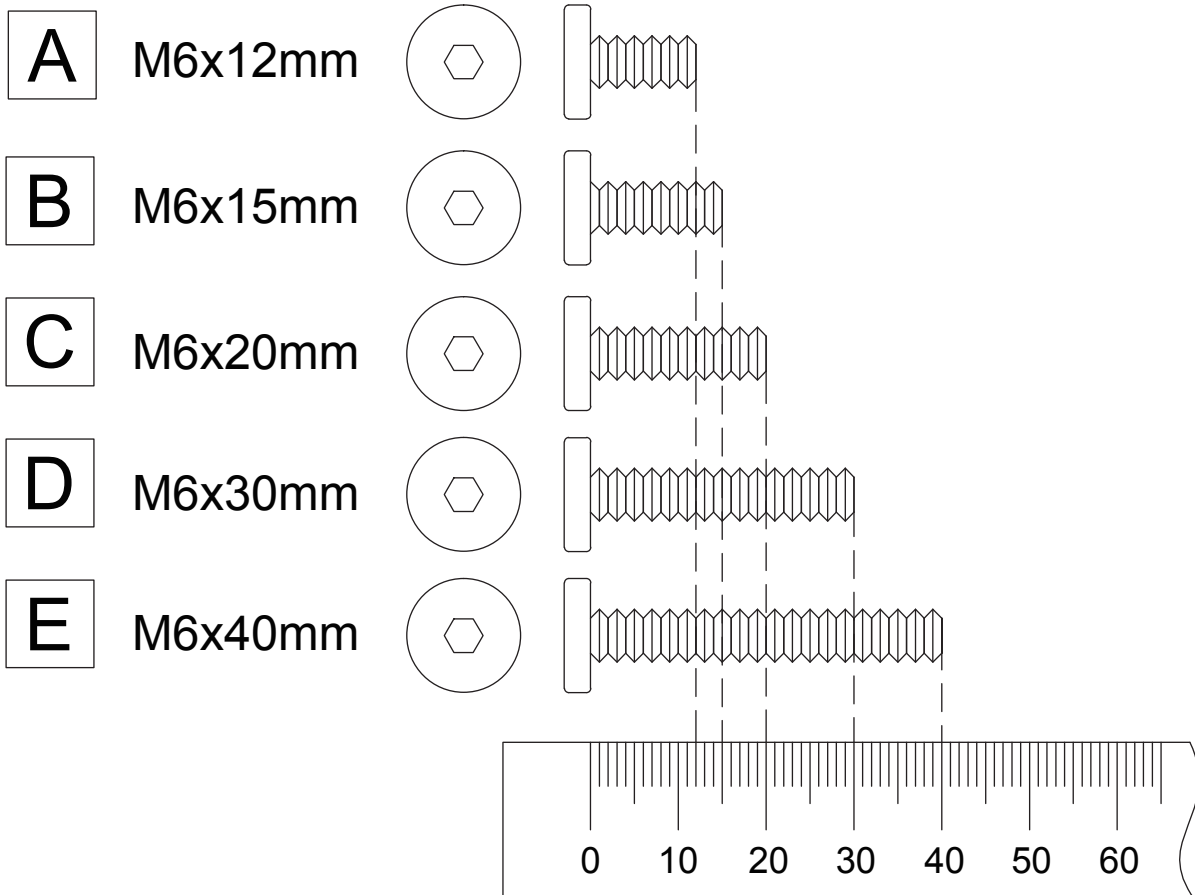

NOTED:

1. Do not fully tighten all bolts until all parts are in place.

Failure to follow these instructions may cause the bolt to misalign during assembly.

1

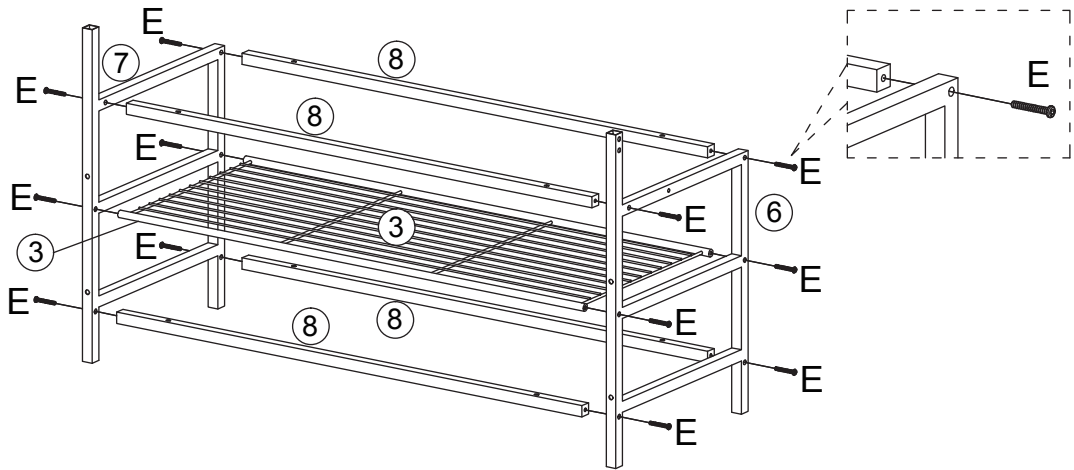

Ex12



M6x40mm

2

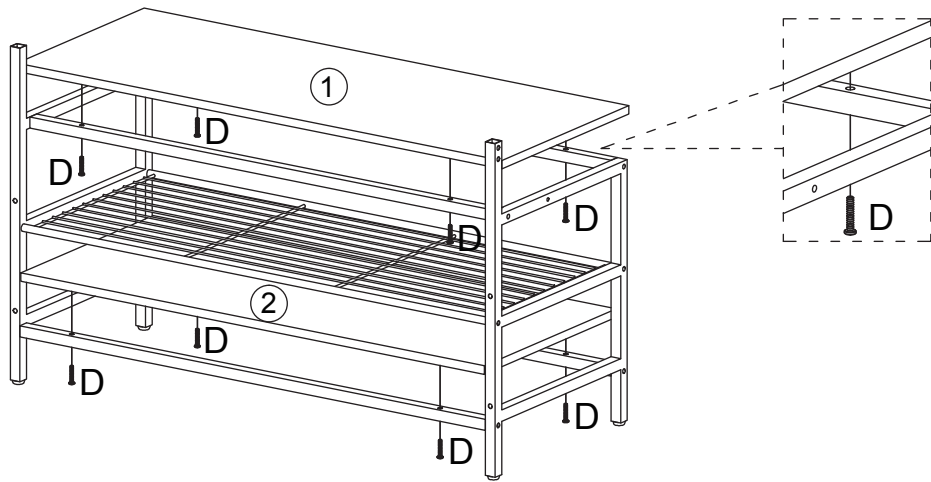

Dx8



M6x30mm

3

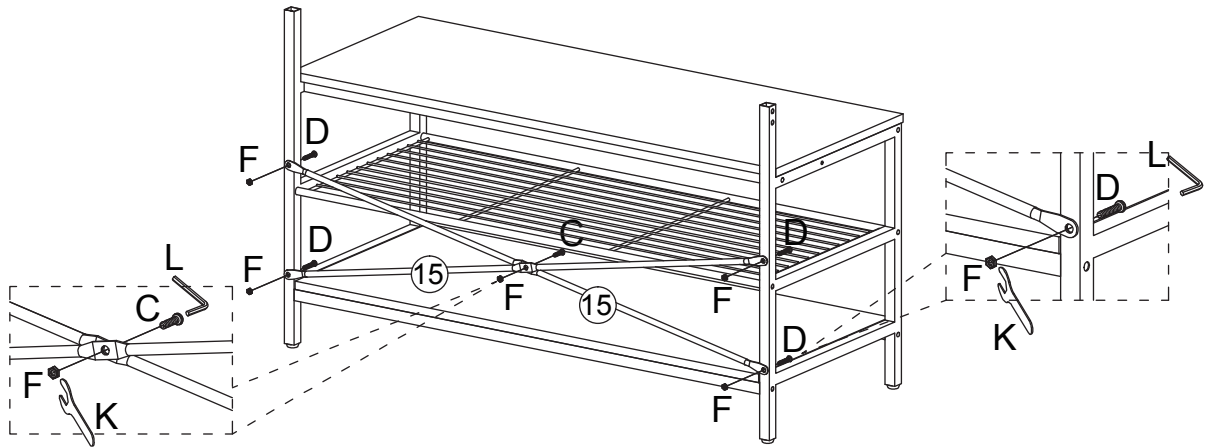

Cx1



M6x20mm

Dx4



M6x30mm

Fx5



M6

4

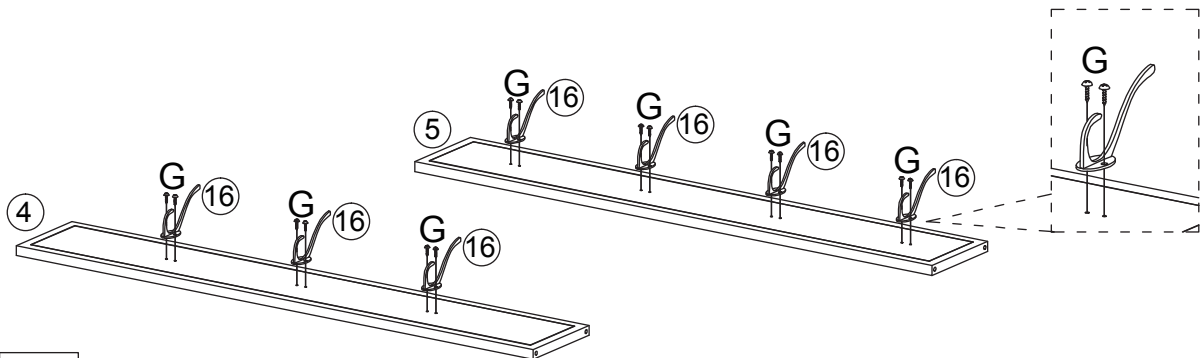

Gx14



4.0x14mm

5

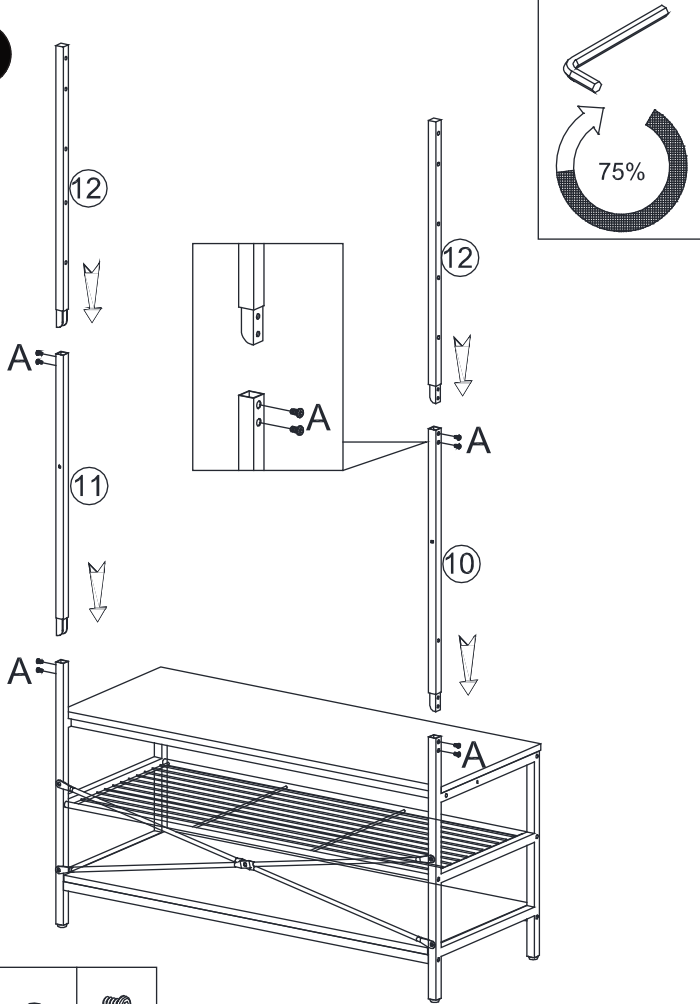

Ax8



M6x12mm

6

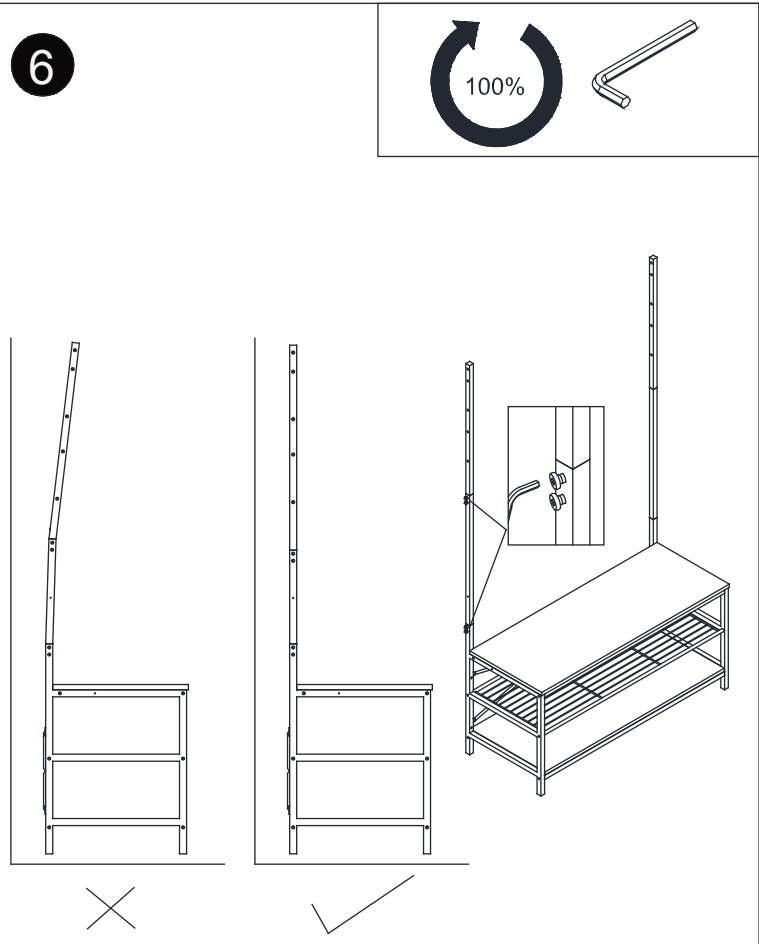

7

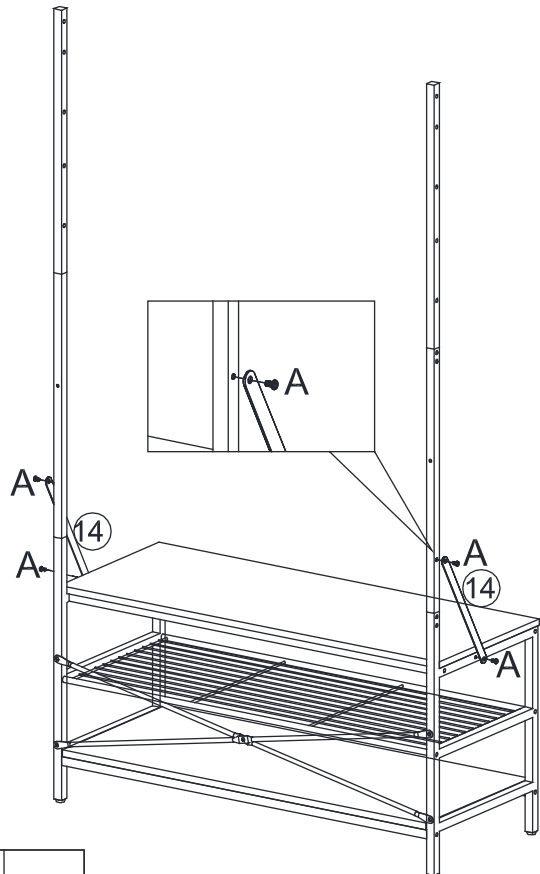

Ax4



M6x12mm

8

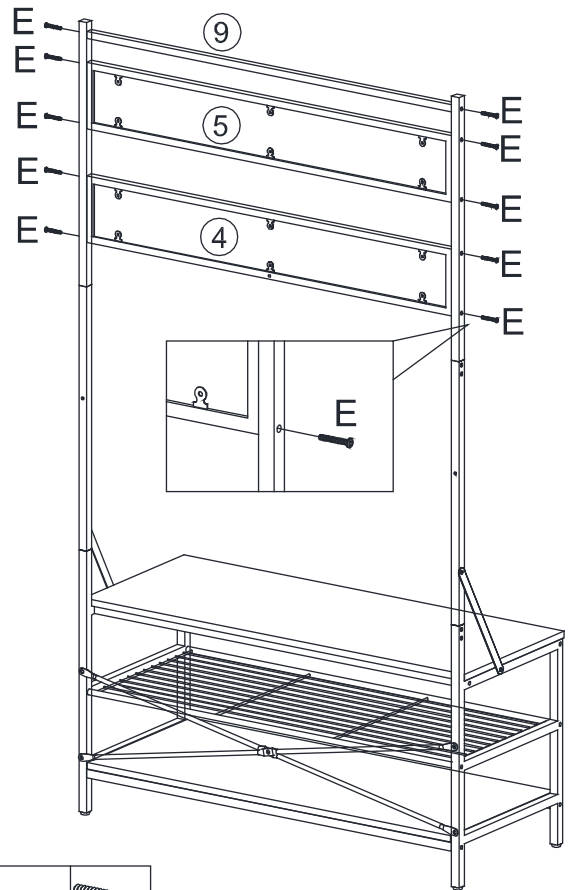

Ex10



M6x40mm

9

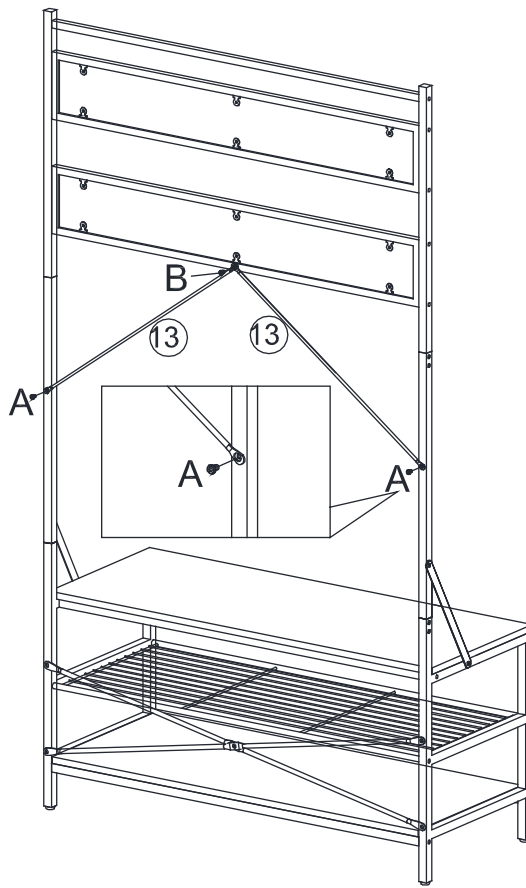

Ax2



Bx1



10

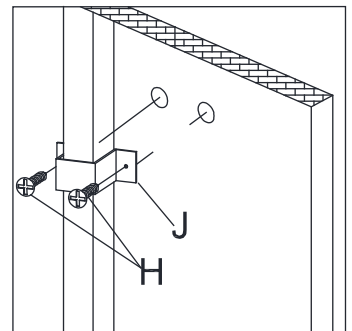
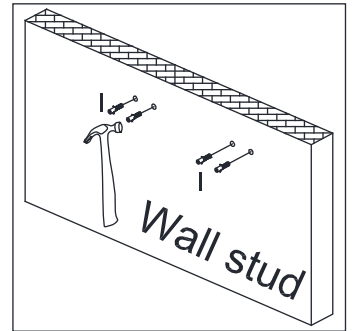
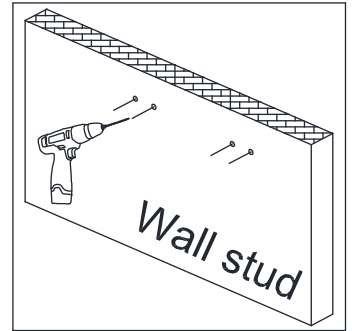
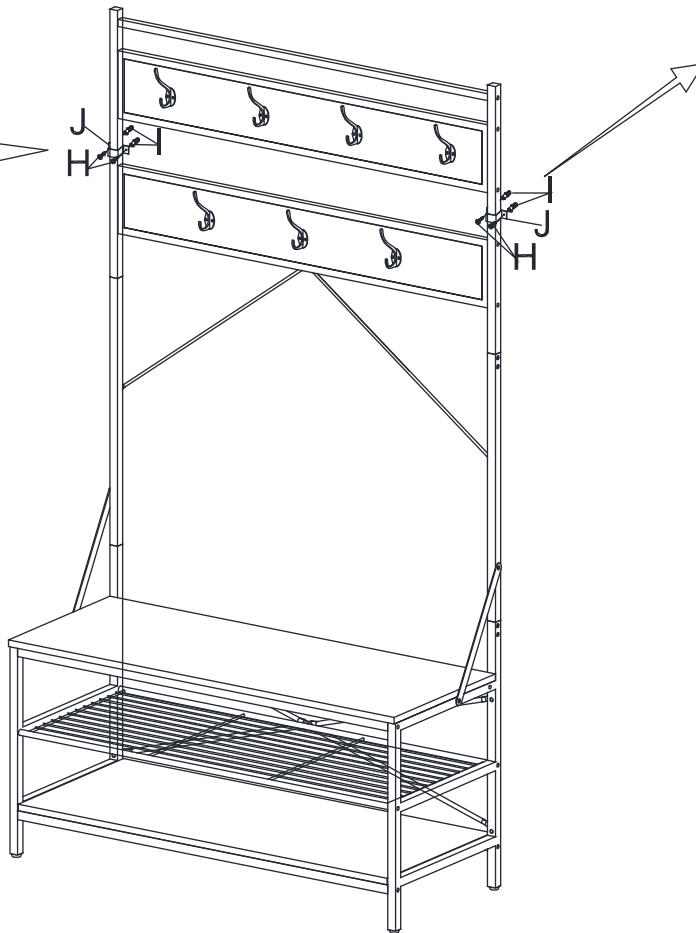
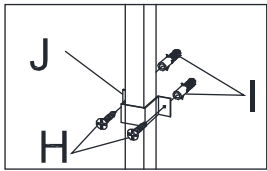

Hx4



I x4



J x2



ANY QUESTIONS, PLEASE FEEL FREE TO CONTACT US
 SELLER CONTACT INFORMATION: contacts@ihomdec.com