

# SIDEBORD

MODEL:SB-UNIQ-12075-WH

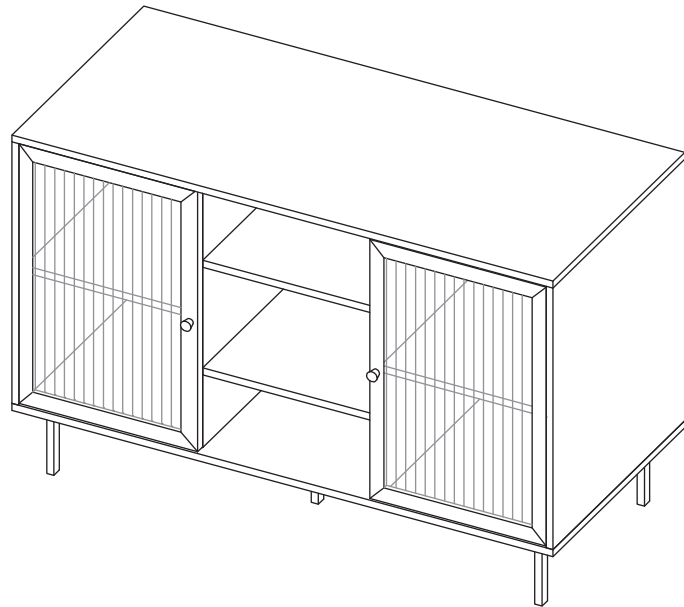

## ASSEMBLY INSTRUCTIONS

Please read instructions carefully before assembly.



Two persons and tools required for assembly

### HARDWARE

A	x8	B	x8	C	x32	D	x24	E	x16	F	x12
7x35mm	15x12mm	Ø6x30mm	M4x40mm			M3x14mm					
G	x2	H	x6	I	x2	J	x2	K	x2	LA	x2
	M3x14mm			M4x18mm	M3x12mm						
M	x22	N	x2	O	x2	P	x2	Q	x1	LB	x2
M4x14mm	M4x30mm									M3x12mm	

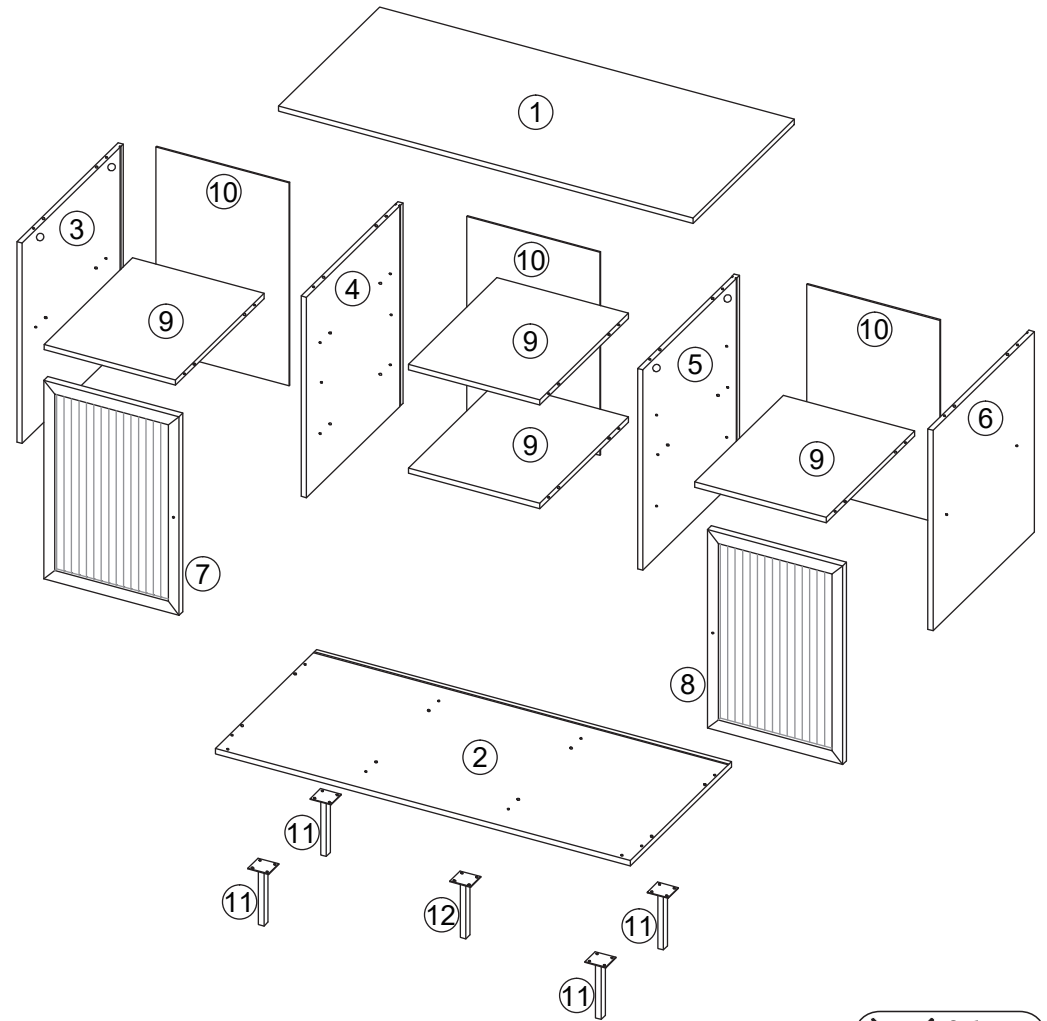

## PARTS

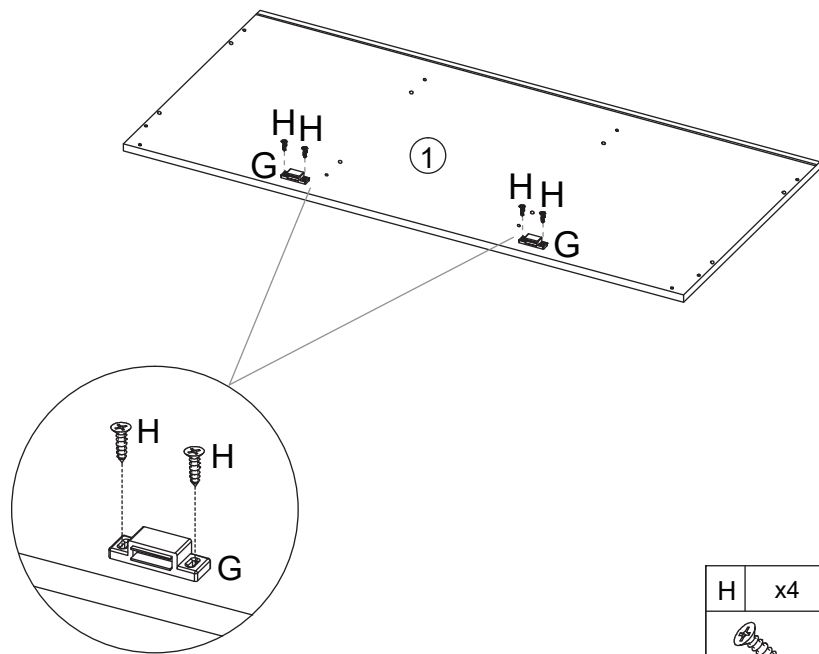

Wipe only with a dry cloths

1



H	x4	G	x2
			
M3x14mm			

3

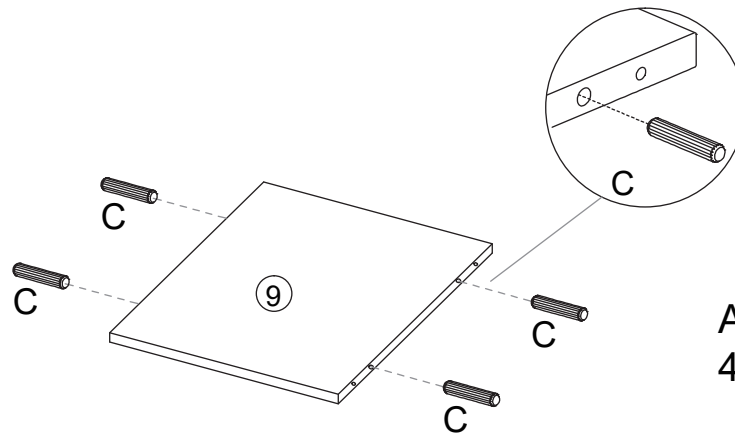

Assemble  
4 sets  
**x4**

C	x16
	
Ø6x30mm	

2

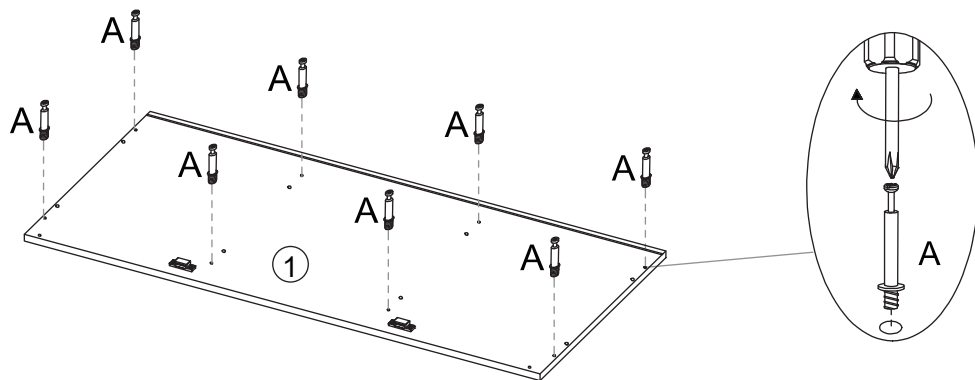

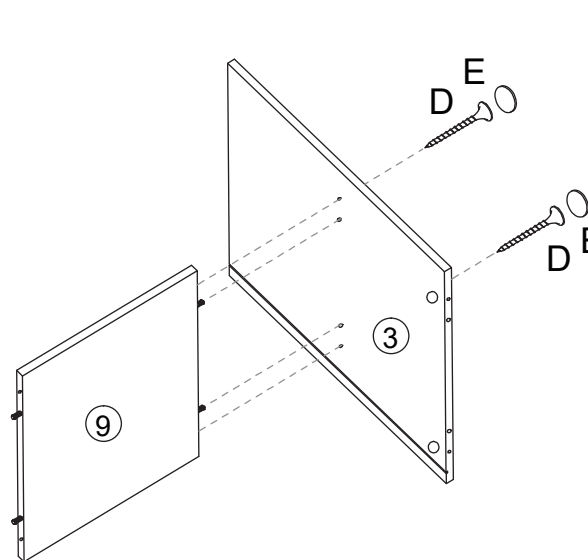

A	x8
	
7x35mm	

4





Peel off the  
cover from F  
and place it  
over D

D	x2	E	x2
			
M4x40mm			

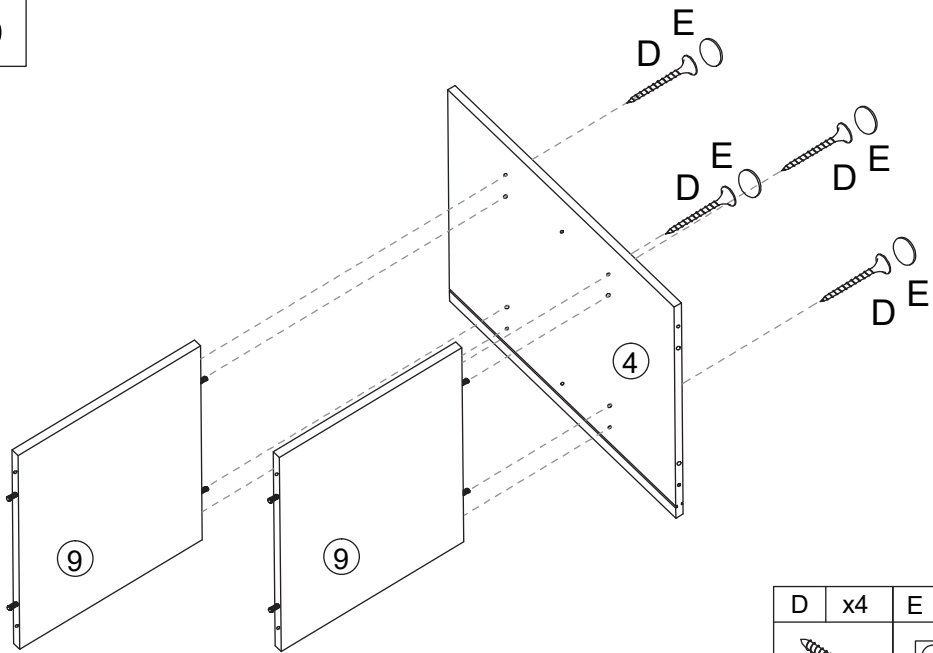

5

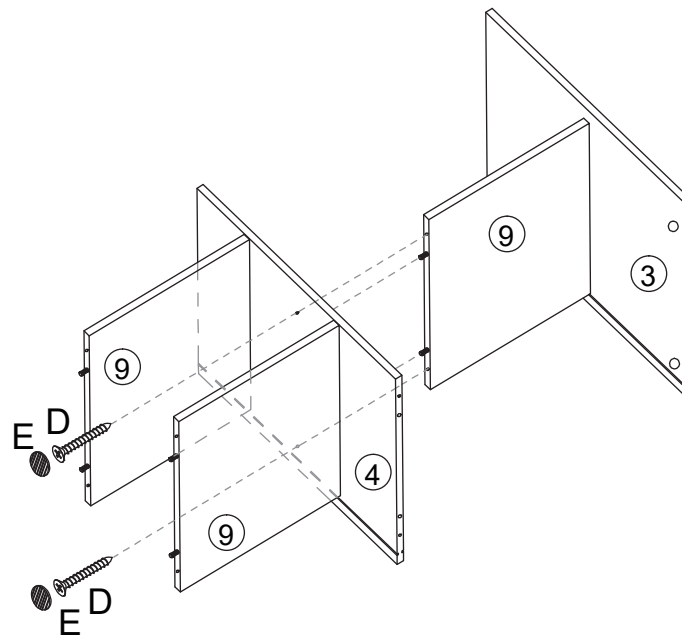

D	x4	E	x4
			
M4x40mm			

7



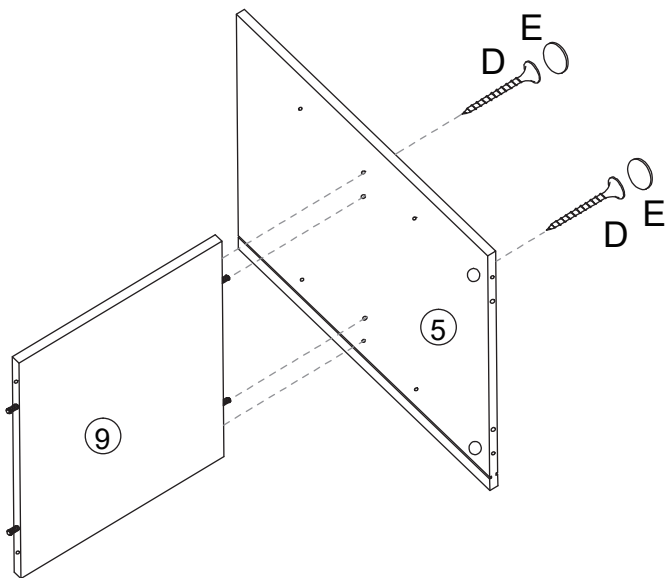

D	x2	E	x2
			
M4x40mm			

6





Peel off the cover from F and place it over D

D	x2	E	x2
			
M4x40mm			

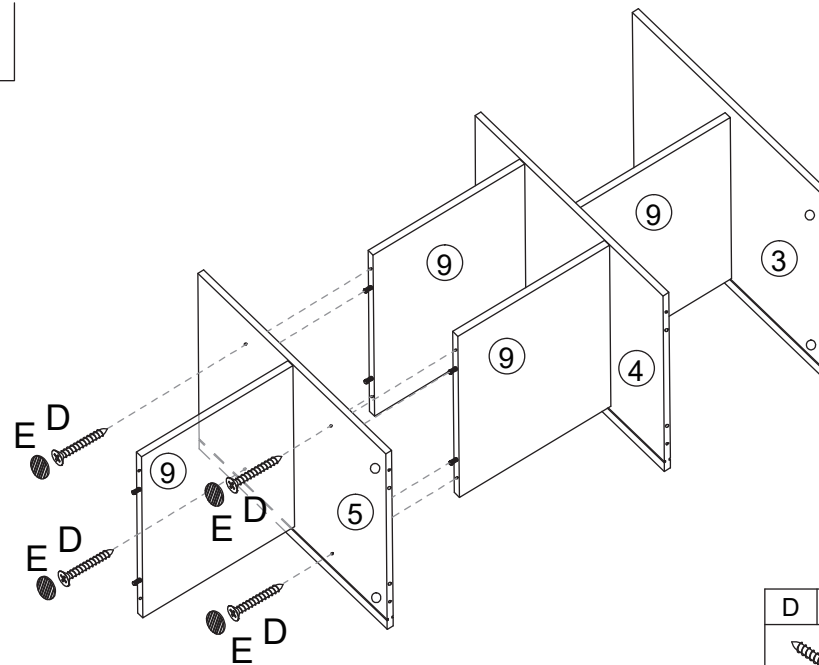

8

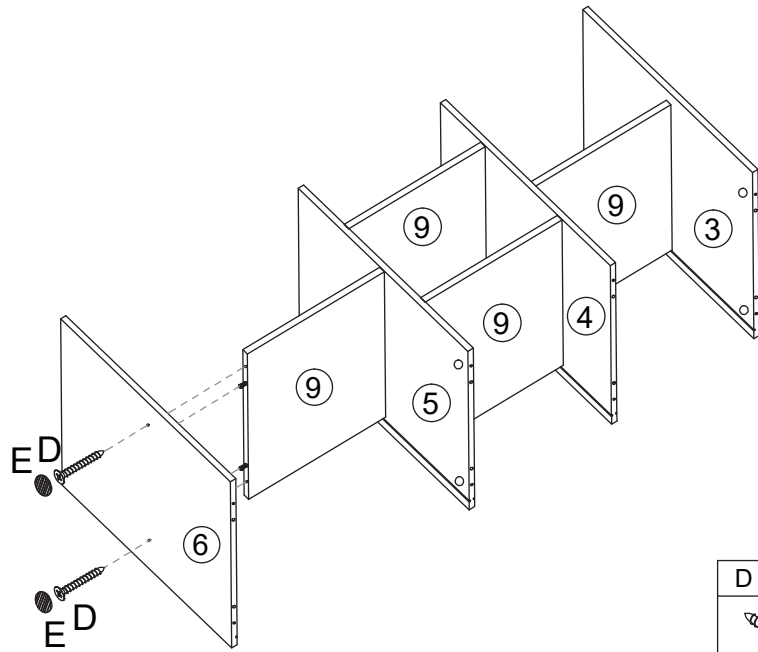

D	x4	E	x4
			
M4x40mm			

9



D	x2	E	x2
			
M4x40mm			

11

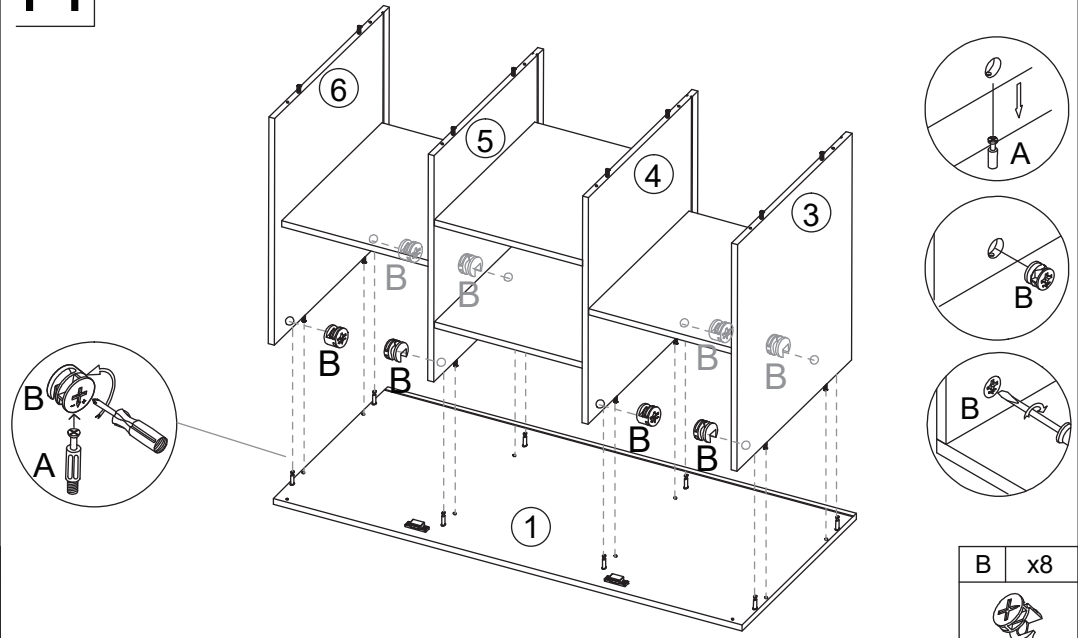

B	x8
	
15x12mm	

10

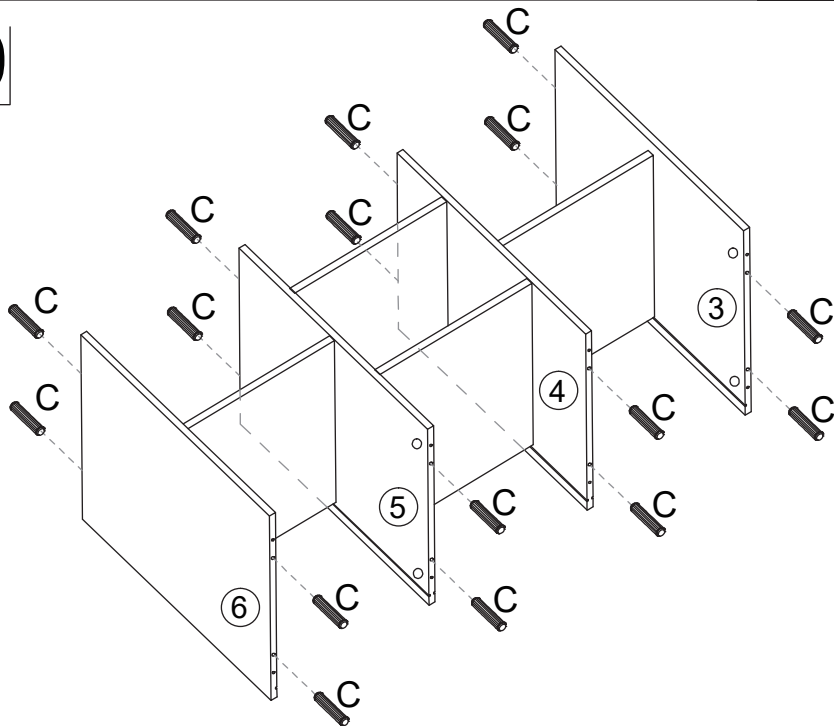

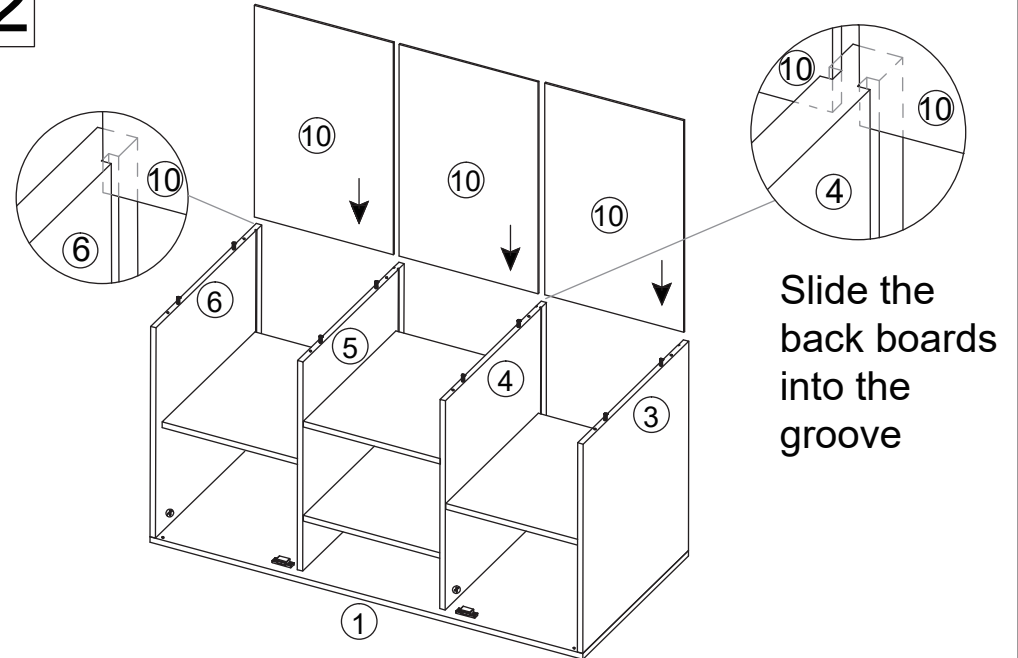

C	x16
	
Ø6x30mm	

12



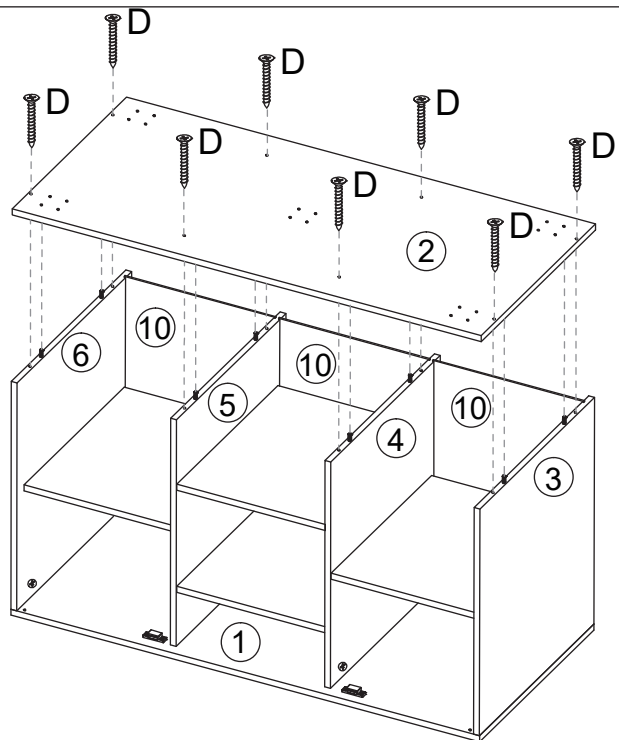

# 13



D	x8
	
M4x40mm	

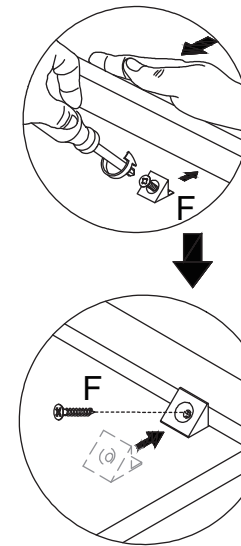
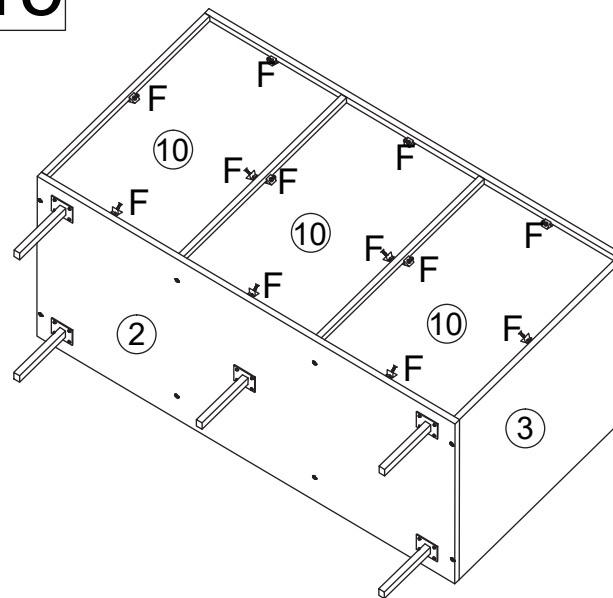

# 15



F	x12
	
M3x14mm	

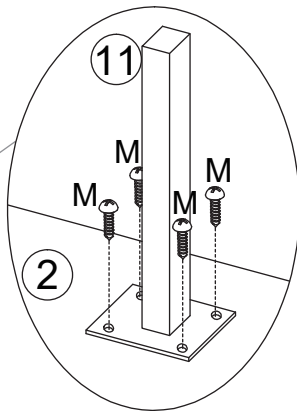
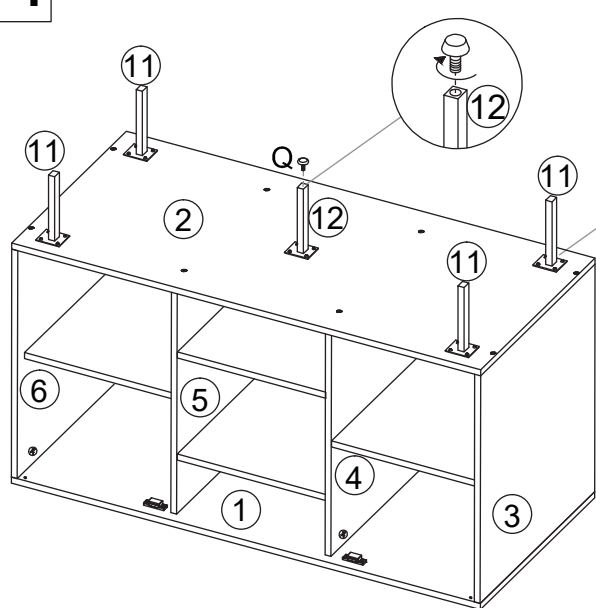



# 14

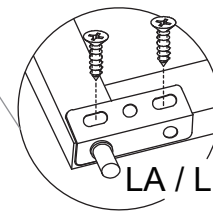
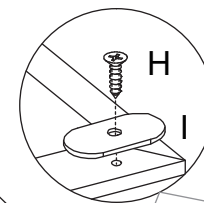
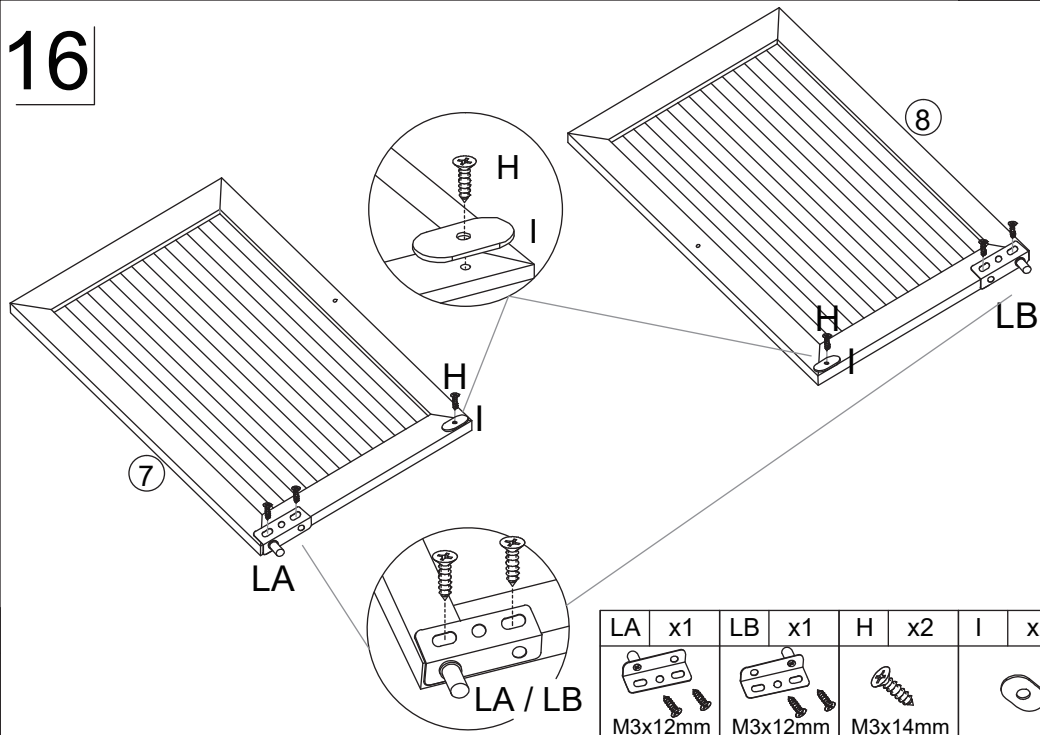

Q	x1	M	x20
			
M4x14mm			

# 16



LA	x1	LB	x1	H	x2	I	x2
							
M3x12mm		M3x12mm		M3x14mm			

# 17

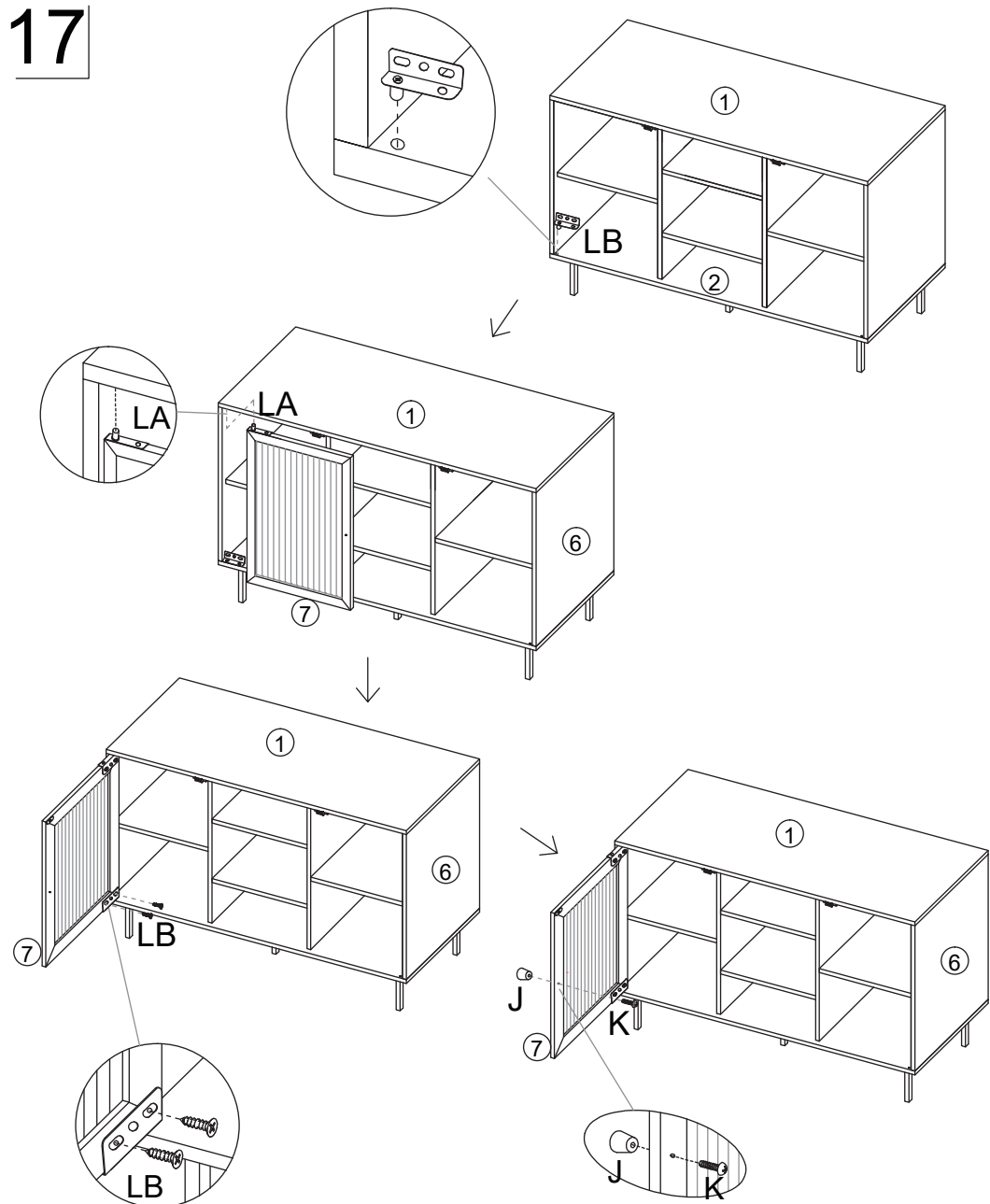

LB	x1	J	x1	K	x1
M3x12mm				M4x18mm	

# 18

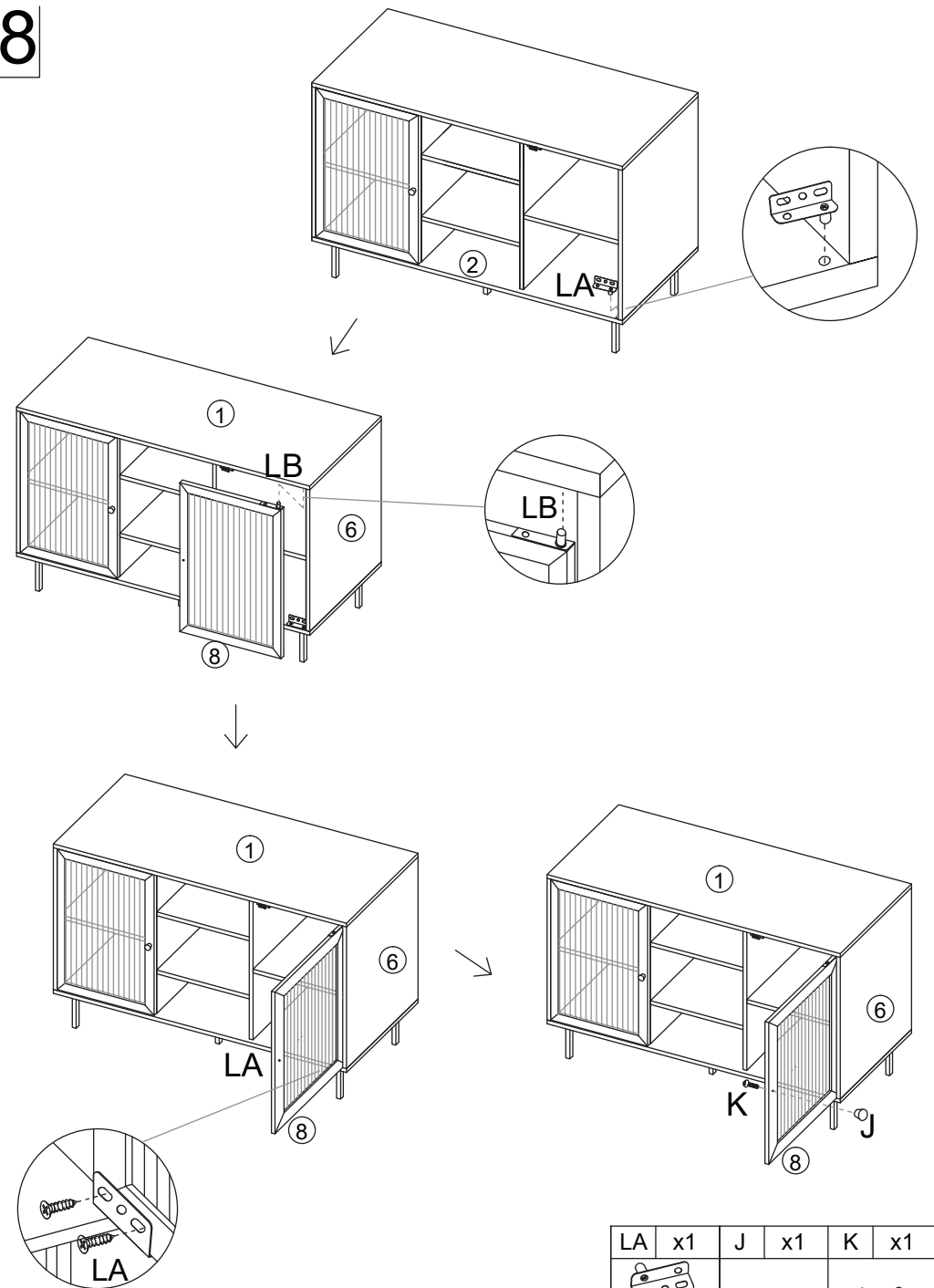

LA	x1	J	x1	K	x1
M3x12mm				M4x18mm	

# 19

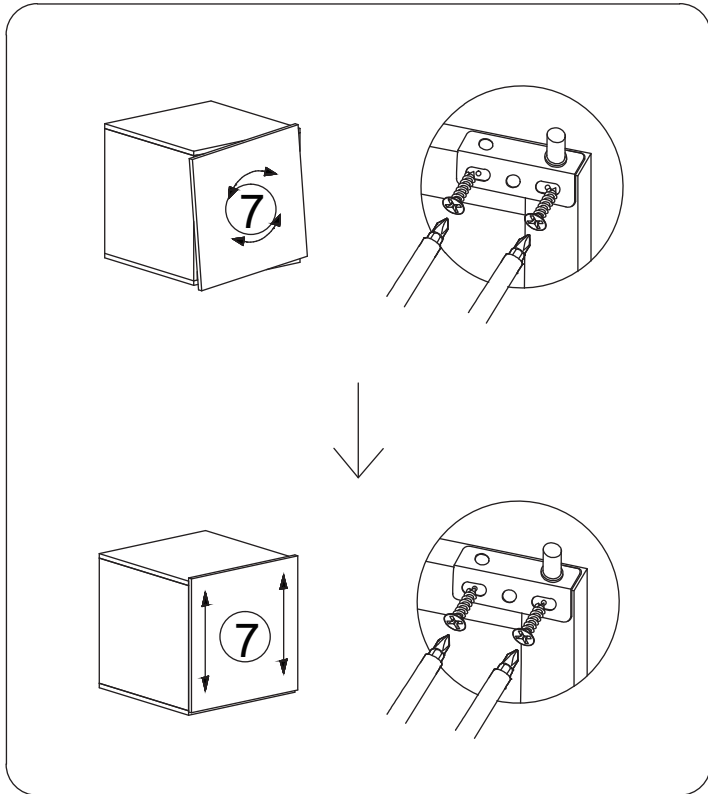
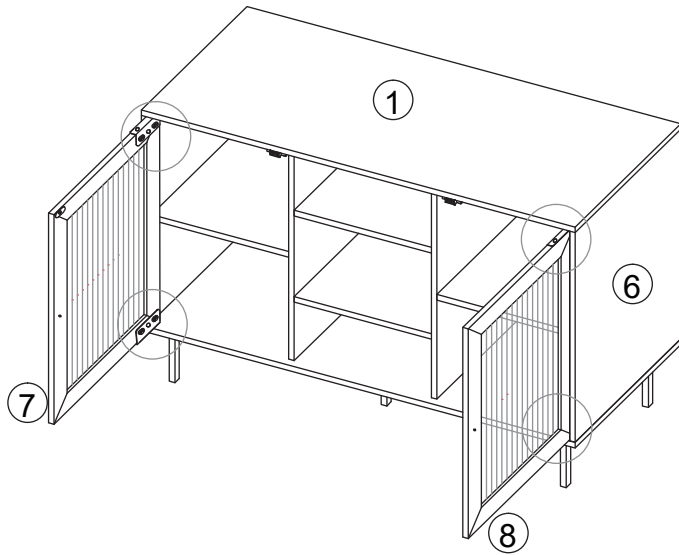

# 20

Optional

Mark out the position on a wall and drill a hole.

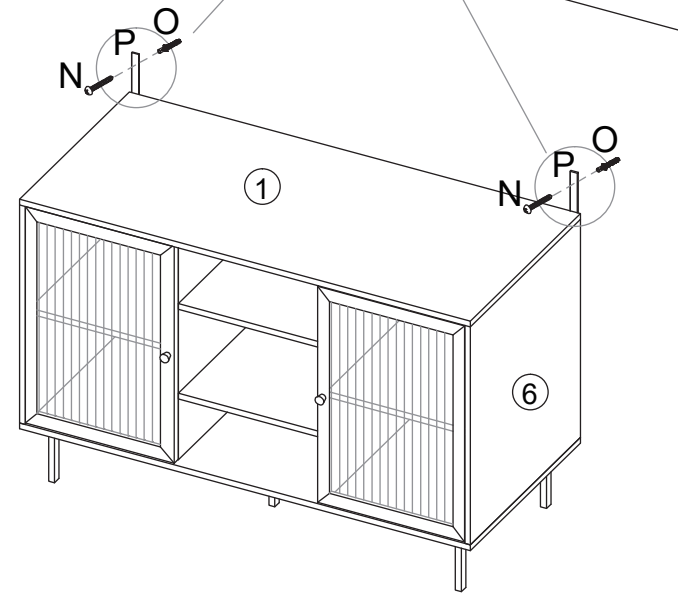
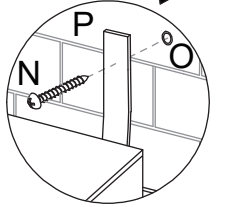
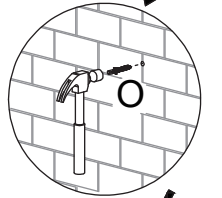
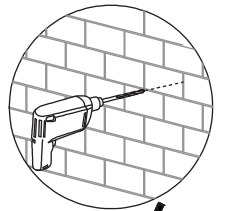
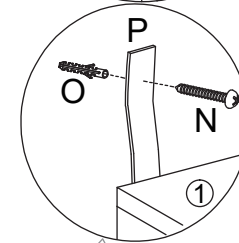
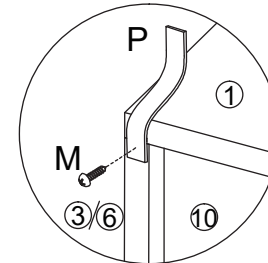

M	x2	N	x2	O	x2	P	x2
M4x14mm		M4x30mm					

# CARE AND MAINTENANCE - FURNITURE

## GENERAL

- Periodically check all screws, bolts and joints connections and tighten them if necessary.
- Periodically check for any damage and deteriorated parts and components and seek repairs or replacements if needed.
- Do not allow any liquids to remain on the furniture as this may cause stains and allow the liquid to be absorbed into the finishes and materials. In some cases, this may also cause warping and/or cracking of the materials and finishes. Use coasters and placemats for all food and beverages.
- Do not place hot items, such as dishes, pots and cups, directly on the furniture. Use coasters and placemats for all food and beverages.
- Keep sharp and pointed objects away from furniture to avoid damaging the surface and finish.
- Do not place the furniture near hot objects, heating vents or heating equipment.
- Do not place the furniture in moist areas, such as bathrooms, to avoid water damage.

## CLEANING AND CARE

- Dust the furniture regularly using a soft cloth or microfibre duster to prevent dust build-up
- Only wipe and clean with a soft, damp cloth with a mild cleaning detergent.
- Do not use abrasive cleaning materials such as scouring pads and chemical cleaning solvents to avoid damage to finishes and paintwork.
- After using or cleaning a glass table top, wipe it completely dry as leaving the glass unattended when wet may leave water marks that cannot be removed easily.
- For upholstery, vacuum regularly with a soft, non-metallic brush to remove dust and grime and to prevent overall soiling. Follow manufacturer's instructions for spot cleaning.
- If removable, wash upholstery covers periodically. If machine washable, use a cold wash cycle.
- Do not use a dryer. Only air dry the upholstery covers.

## ENVIRONMENTAL

- Do not expose the furniture (including outdoor furniture) to direct sunlight. Protect your outdoor furniture with weather-resistant covers, and have curtains and blinds to shield indoor furniture if direct sunlight is unavoidable.
- Bamboo, rattan as well as wood-based furniture are prone to damage and fade with prolonged exposure to extremely high or low humidity conditions. Do not place them in such extreme conditions.
- For outdoor bamboo/rattan furniture, do not place the furniture in shady or moist areas to prevent it from moulding. Bring the furniture indoors during the off season or covered it with weather-resistant covers.

## HANDLING

- Do not drag, push or pull furniture when moving them. Lift them up to avoid damage to the furniture legs and scratches on floors.
- Do not sit or stand on the armrests or use the furniture as a stepping stool for safety reasons.
- Do not exceed the recommended weight capacities of the furniture specified.
- Do not use the furniture for any other purpose other than what is intended for.

## STORAGE

- Store furniture in a clean, dry environment when not in use.
- If possible, disassemble furniture before storing to save space and prevent damage during transportation.

## SPECIFIC CARE

- Engage professional upholstery cleaning services for deeper cleaning if required.
- For genuine leather, suede leather or synthetic leather upholstery, use an appropriate leather conditioner to maintain its suppleness and appearance and prevent drying and cracking. The conditioner also adds a thin protective layer on the leather surface to facilitate easier cleaning.
- If a furniture polish is used for wooden furniture, make sure that it is of low alcohol content.
- To prevent rattan from becoming dry and brittle, spray water on the underside of the furniture piece every six months and wipe down with a dry cloth to remove excess water.
- As an optional protection for bamboo furniture, apply a bamboo sealant/varnish on it for durable protection against scratches, water, UV rays and other weather elements.

**⚠ WARNING**



**Children have died from furniture tipover.**

- ALWAYS secure this furniture with an anchor device.
- NEVER allow children to stand, climb or hang on drawers, doors, or shelves.