

# ASSEMBLY INSTRUCTIONS

Please read the instructions carefully before assembly and keep it for future reference.

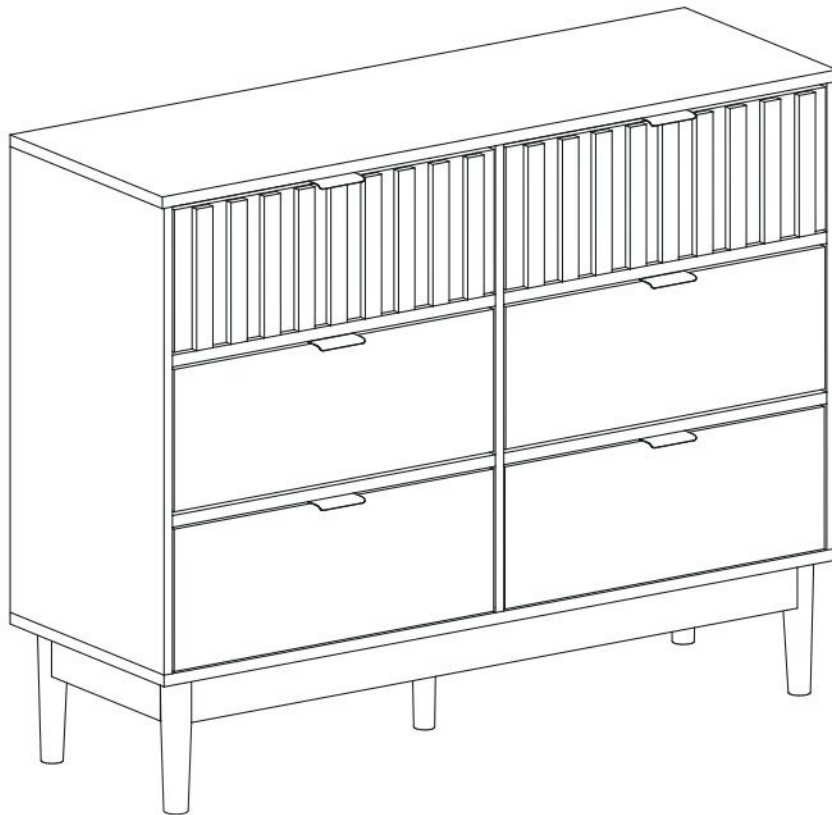
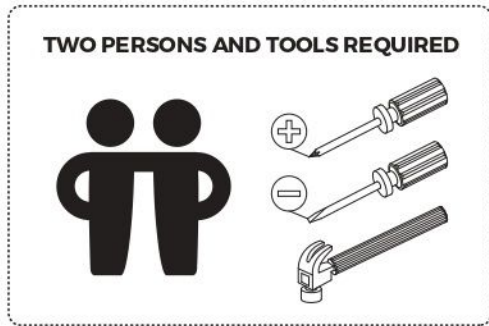

---

**Model** : COD-YAKO-6D  
**Version 1.0**

## Assembly and Maintenance Tips



1. Keep children and pets away from the working area as small parts may cause choking if swallowed.



2. Some furniture may require two persons to assemble for safety reasons.

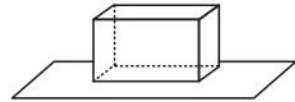

3. To protect the surfaces of the furniture, lay the parts and perform the assembly on top of a soft mat (such as a carpet or cardboard).



4. Keep the furniture away from direct sunlight to avoid fading.



5. Use a soft, damp cloth to clean or wipe surfaces.



6. Never use ammonia-based or abrasive cleaning products to clean as they may damage the finish.



7. Do not place liquids or wet items on furniture as they may leave water marks/stains. Always use a coaster or runner to protect the furniture surface.

# Assembly Checklist

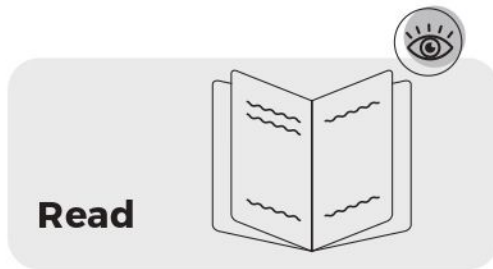

Read through the instructions carefully before you begin.

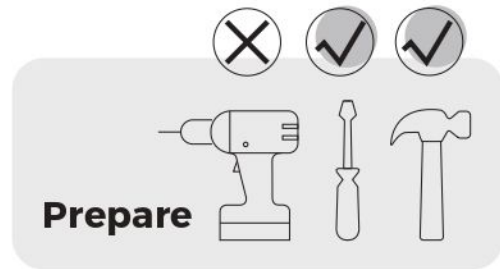

Make sure you have all the required tools. Never use power tools unless instructed.

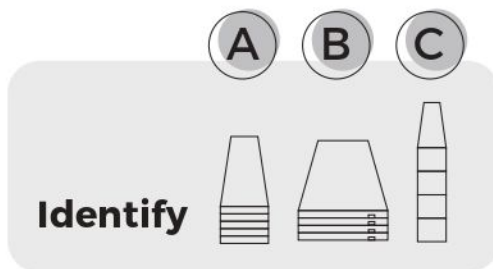

Identify and lay out all of the components before you begin assembly.

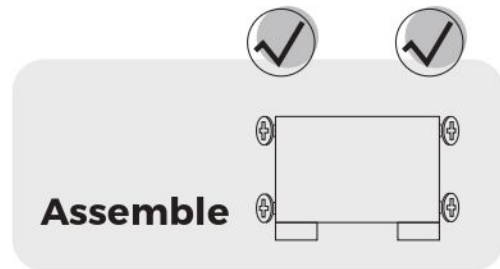















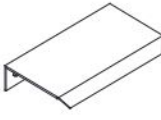

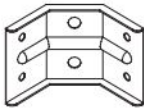
Please fully tighten all screws during the assembly process unless instructed not to do so.

## Helpful Information

- ! Never use power tools unless specifically instructed. They can damage your components or hardware if used incorrectly.
  - ! The most common mistakes made during assembly are using the wrong hardware or getting components back to front.
  - ! When assembling the product, it is recommended to do so on top of a soft surface such as a carpet or cardboard to avoid scratches and damages to the furniture surfaces.
  - ! Bulky items such as wardrobes should be assembled in the location when the assembled piece will be used to avoid moving them through doors or tight passages.
  - ! Never use any glue until you are certain that the parts belong together.
  - ! Periodically check that all connections are secured and follow all care and maintenance instructions stated.
  - ! If you encounter any assembly difficulties or missing components and/or hardware, please contact our Customer Service for further assistance.
-

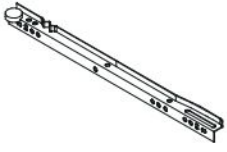
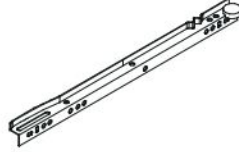
# Hardware List

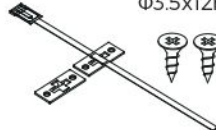
Please ensure that all parts and hardware are in the packaging contents. If there are any missing parts and/or hardware, please contact our Customer Service as soon as possible.





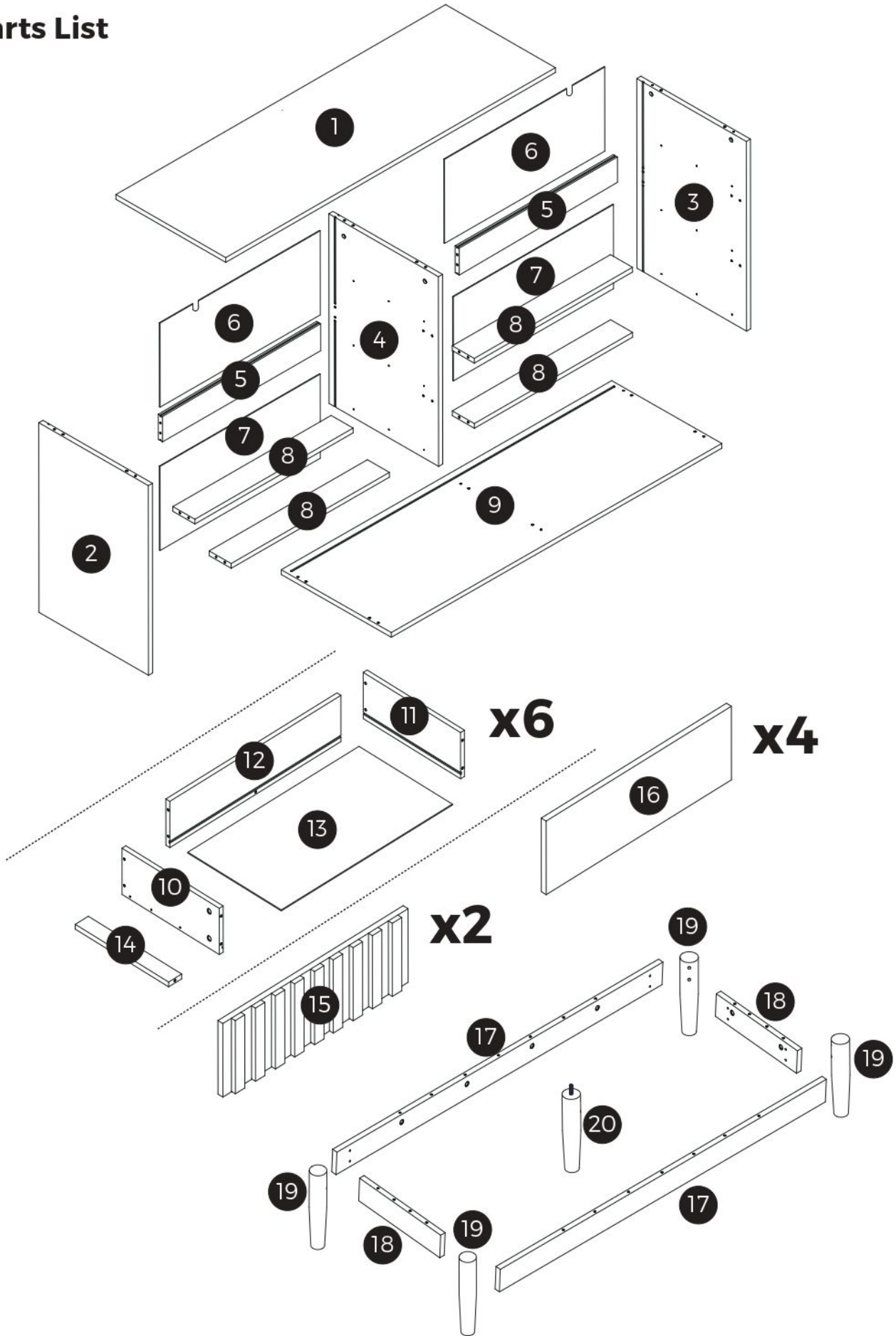







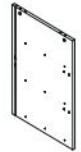
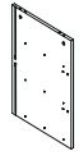

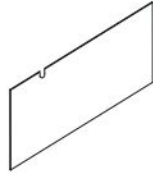
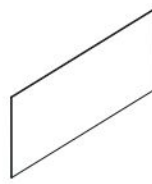

<p><b>Part A</b> 72pcs 6x35mm</p> 	<p><b>Part B</b> 72pcs 15x9.2mm</p> 	<p><b>Part C</b> 22pcs Φ6x30mm</p> 	<p><b>Part D</b> 40pcs Φ4x35mm</p> 
<p><b>Part E</b> 84pcs Φ3x12mm</p> 	<p><b>Part F</b> 6pcs</p> 	<p><b>Part G</b> 1pc</p> 	<p><b>Part H</b> 1pc</p> 
<p><b>Part I</b> 4pcs</p> 	<p><b>Part J</b> 20pcs Φ4x12mm</p> 	<p><b>Part K</b> 8 sets Φ6x40mm</p> 	<p><b>Part L</b> 1pc</p> 
<p><b>Part M</b> 6pcs LENGTH:30CM</p> 	<p><b>Part N</b> 6pcs LENGTH:30CM</p> 	<p><b>Part O</b> 6pcs LENGTH:30CM</p> 	<p><b>Part P</b> 6pcs LENGTH:30CM</p> 
<p><b>Part Q</b> 4pcs</p> 	<p><b>Part R</b> 16 sets</p>  <p>Φ3x16mm</p>	<p><b>Part S</b> 2 sets</p>  <p>Φ3.5x12mm</p>	<p><b>Part T</b> 4pcs</p> 

# Parts List

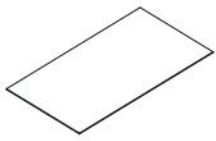
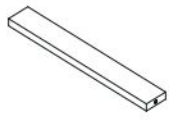

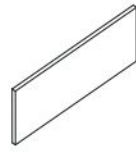
# Parts List

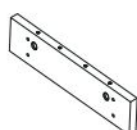
Please ensure that all parts and hardware are in the packaging contents. If there are any missing parts and/or hardware, please contact our Customer Service as soon as possible.

<p><b>Part 1</b> 1pc</p> 	<p><b>Part 2</b> 1pc</p> 	<p><b>Part 3</b> 1pc</p> 	<p><b>Part 4</b> 1pc</p> 
<p><b>Part 5</b> 2pcs</p> 	<p><b>Part 6</b> 2pcs</p> 	<p><b>Part 7</b> 2pcs</p> 	<p><b>Part 8</b> 4pcs</p> 
<p><b>Part 9</b> 1pc</p> 	<p><b>Part 10</b> 6pcs</p> 	<p><b>Part 11</b> 6pcs</p> 	<p><b>Part 12</b> 6pcs</p> 
<p><b>Part 13</b> 6pcs</p> 	<p><b>Part 14</b> 6pcs</p> 	<p><b>Part 15</b> 2pcs</p> 	<p><b>Part 16</b> 4pcs</p> 
<p><b>Part 17</b> 2pcs</p> 	<p><b>Part 18</b> 2pcs</p> 	<p><b>Part 19</b> 4pcs</p> 	<p><b>Part 20</b> 1pc</p> 

# STEP 1

**Part E**  
18pcs  
Ø3x12mm



**Part M**  
3pcs



**Part N**  
3pcs

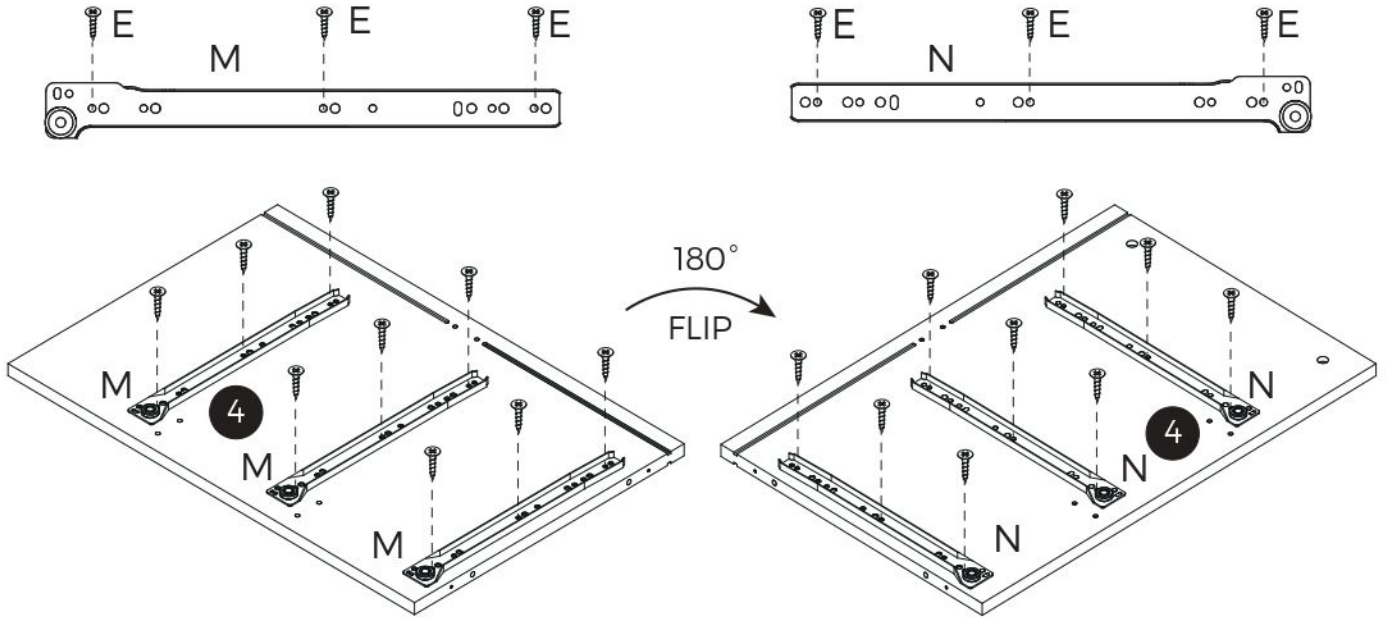
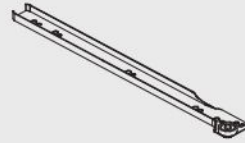

# STEP 2

**Part A**  
12pcs  
6x35mm

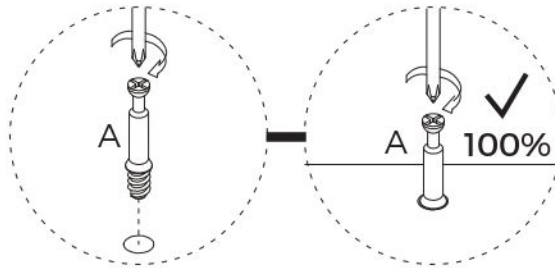

Tighten Part A fully

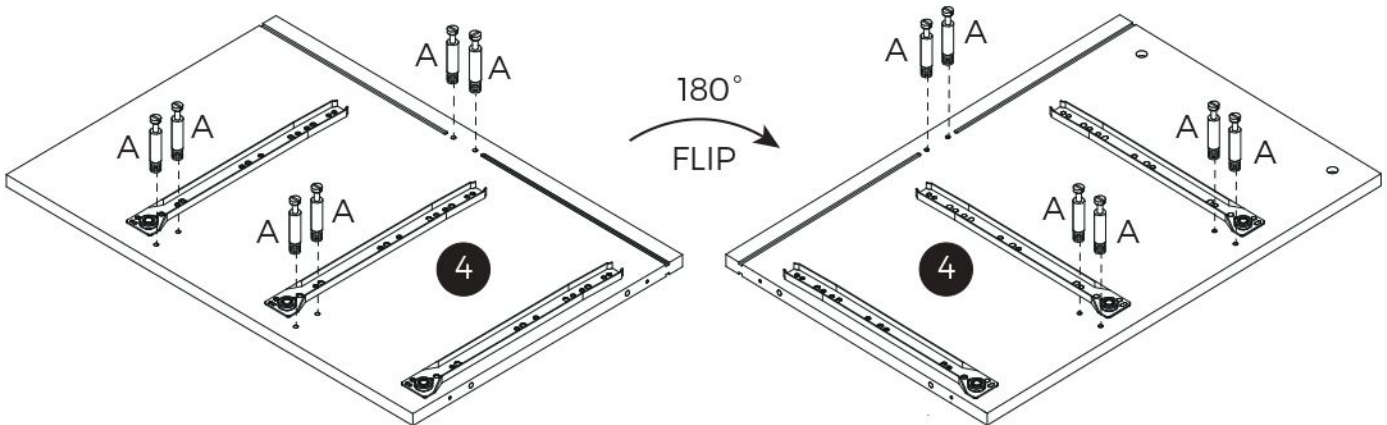

# STEP 3

## Part E

18pcs  
Ø3x12mm



## Part M

3pcs

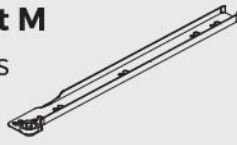

## Part N

3pcs

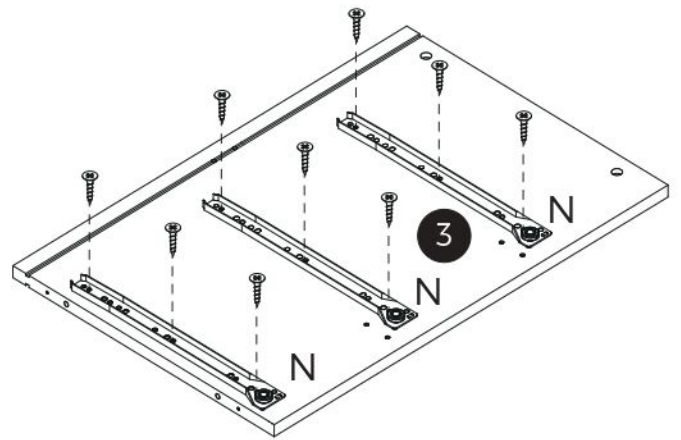
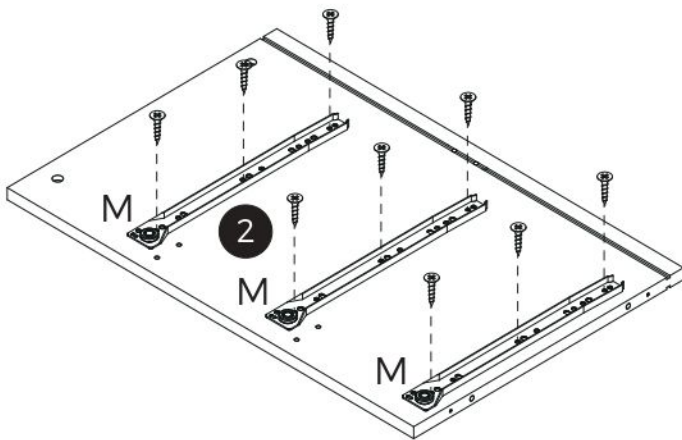
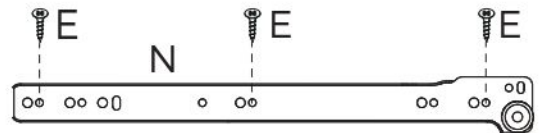
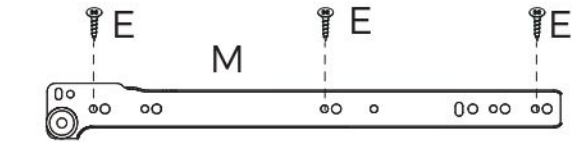
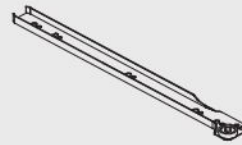

# STEP 4

## Part A

12pcs  
6x35mm

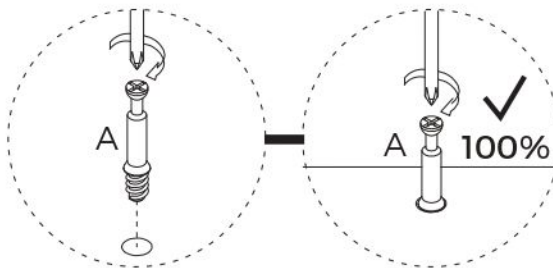

Tighten Part A fully

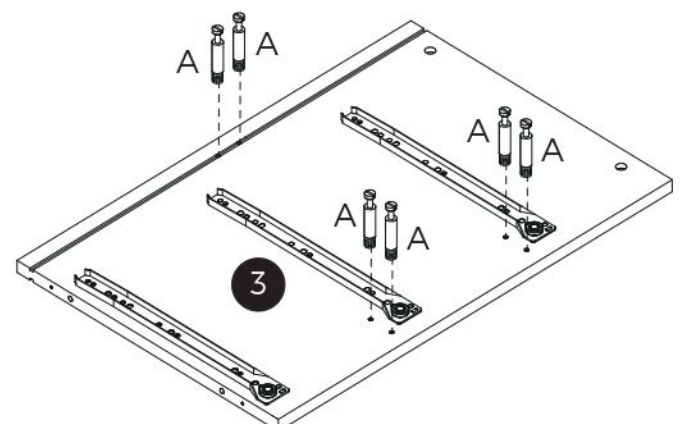
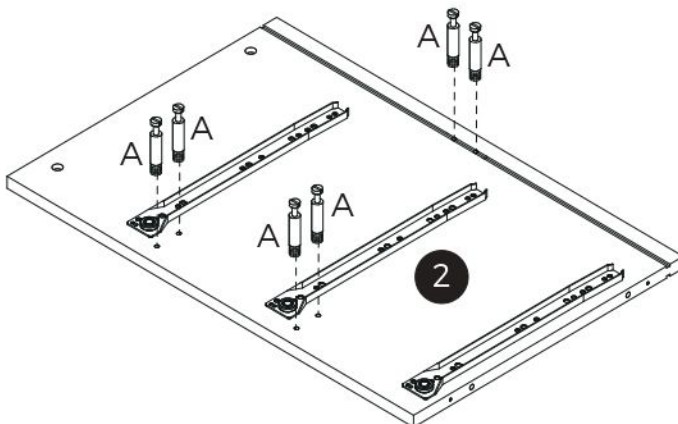

## STEP 5

### Part B

6pcs  
15x9.2mm

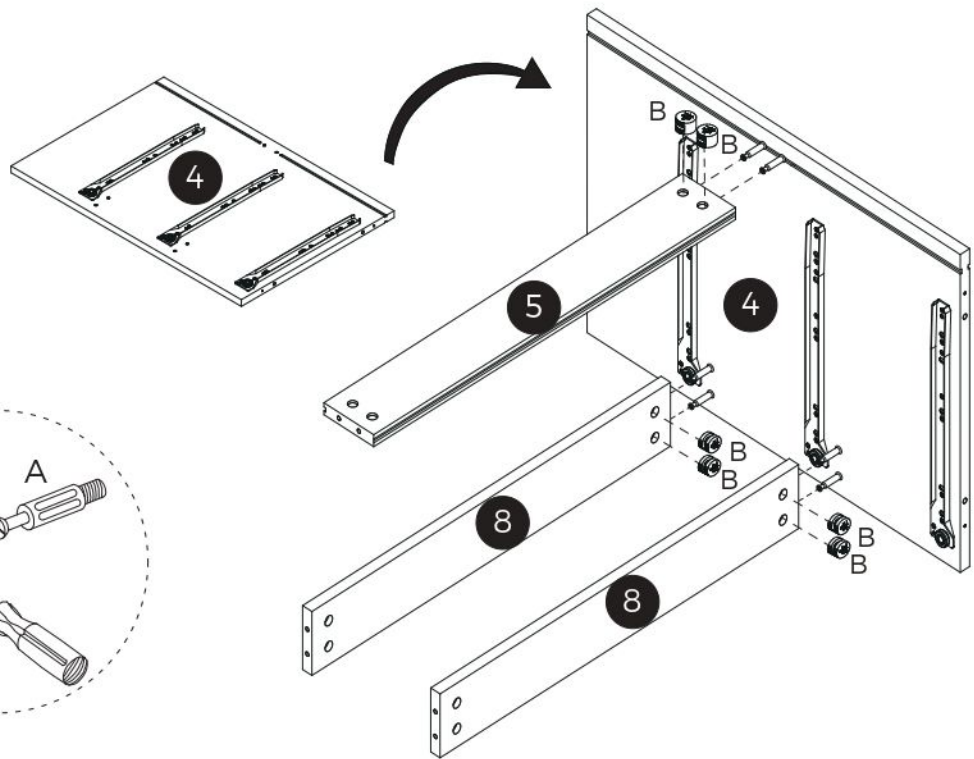
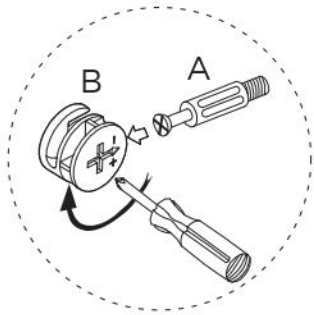

## STEP 6

### Part B

6pcs  
15x9.2mm

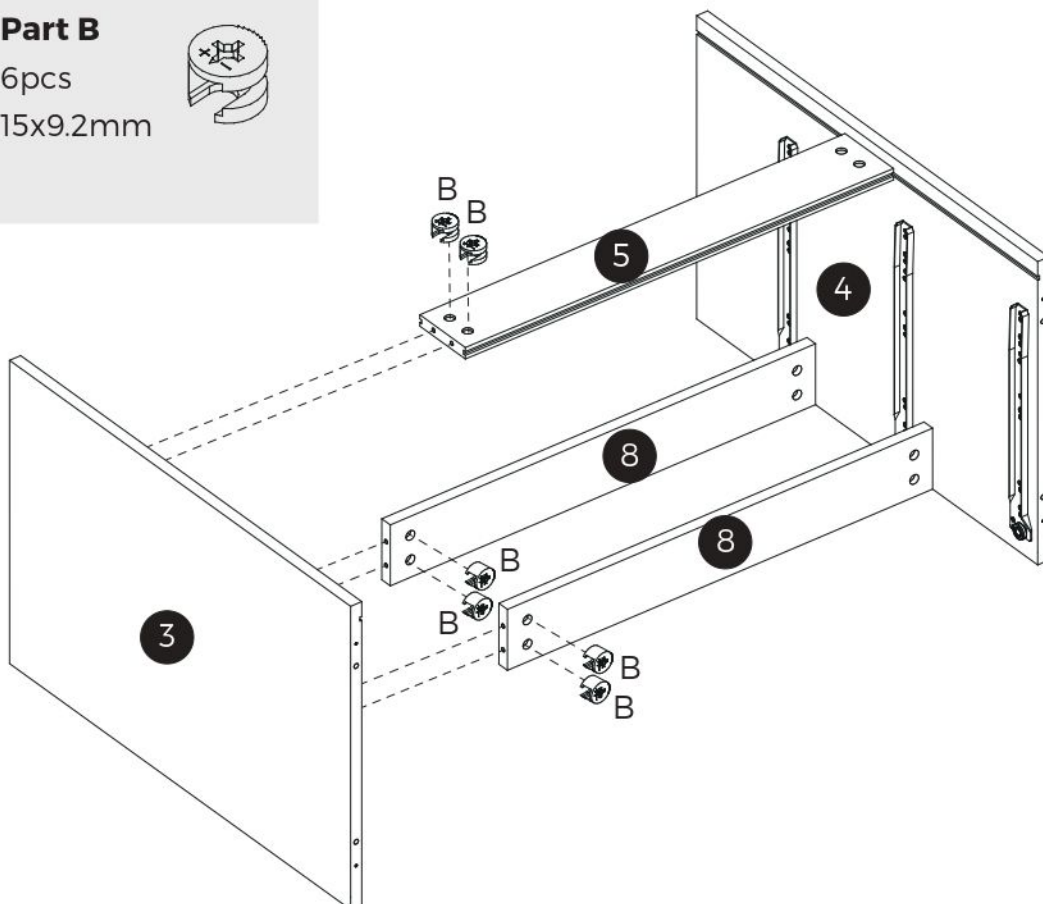
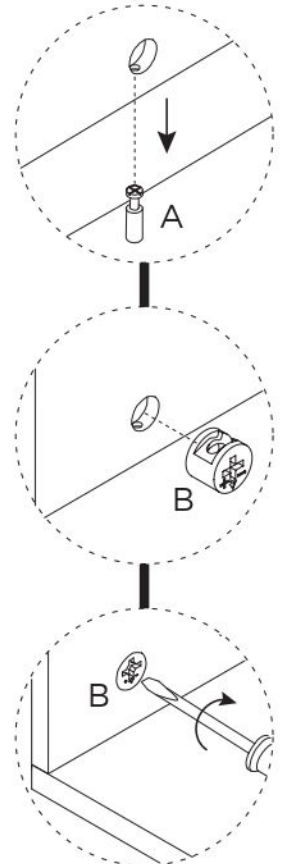

## STEP 7

### Part B

6pcs  
15x9.2mm

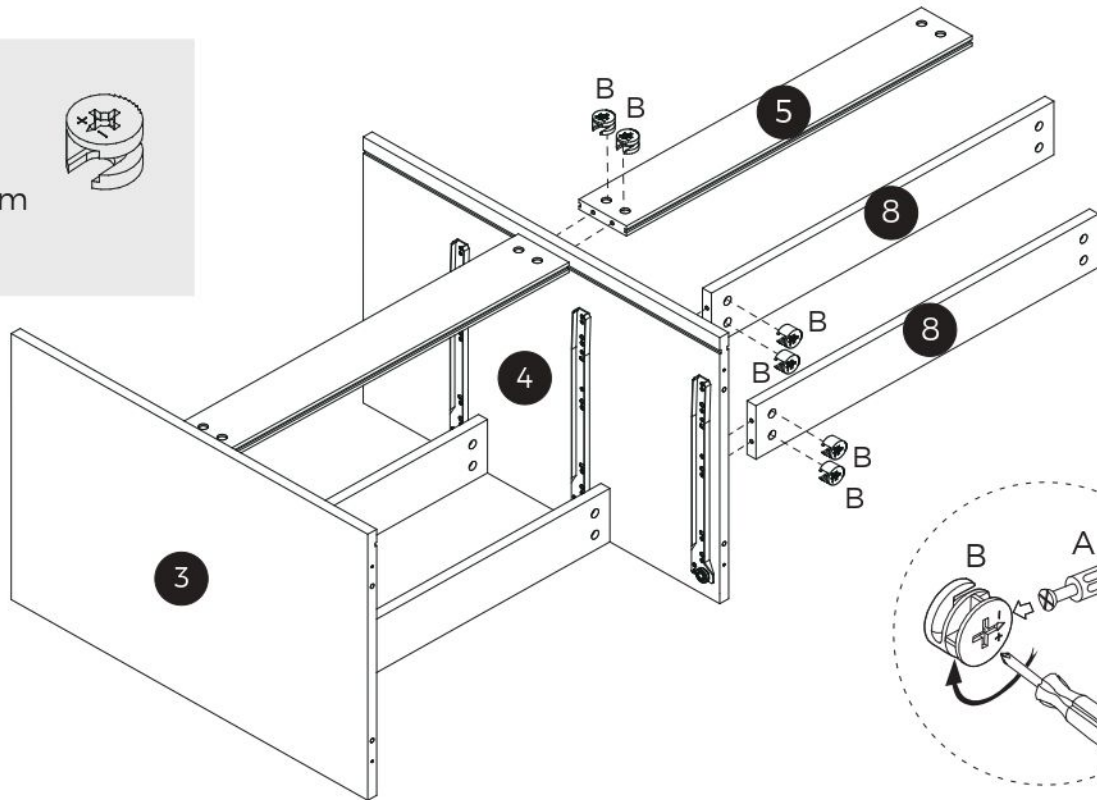

## STEP 8

### Part B

6pcs  
15x9.2mm

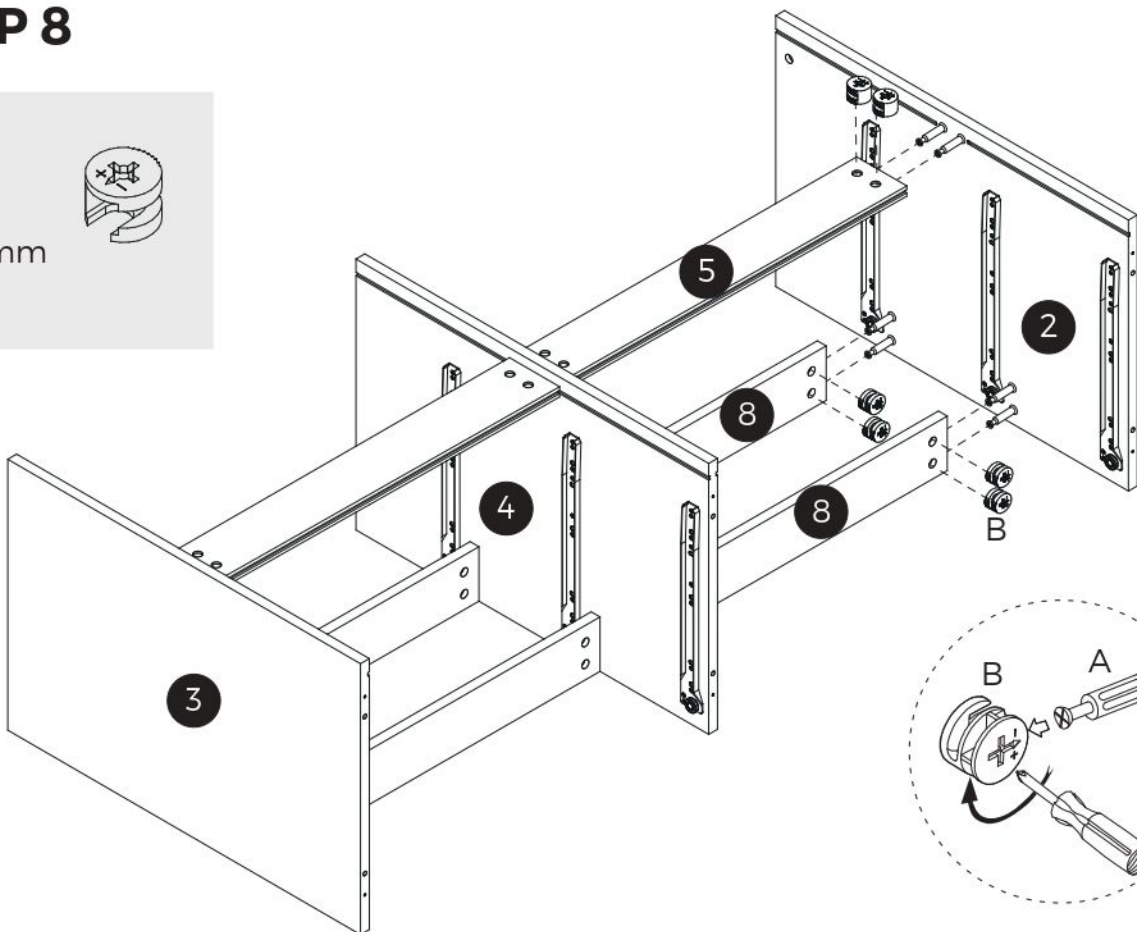

## STEP 9

### Part C

6 pcs  
Ø6x30mm

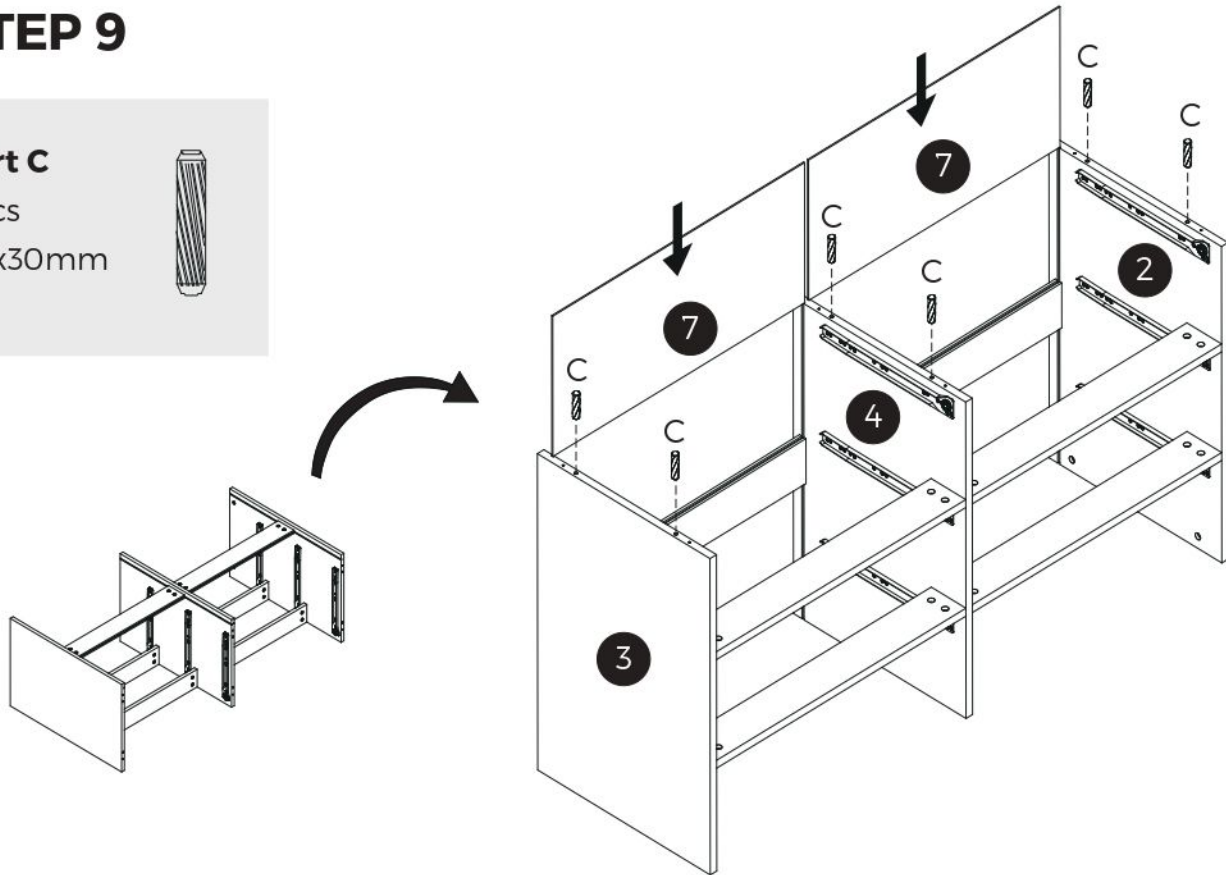

## STEP 10

### Part D

6 pcs  
Ø4x35mm

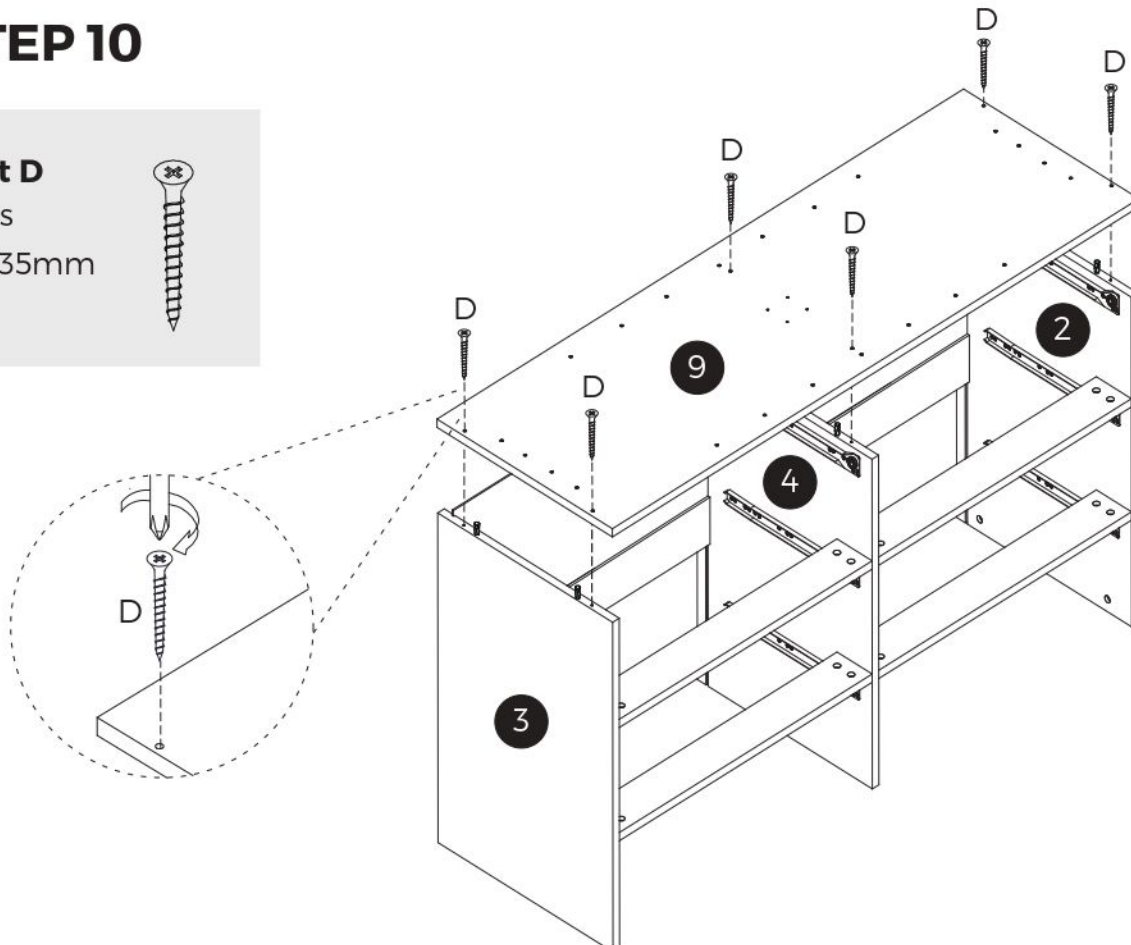

## STEP 11

### Part A

12pcs  
6x35mm

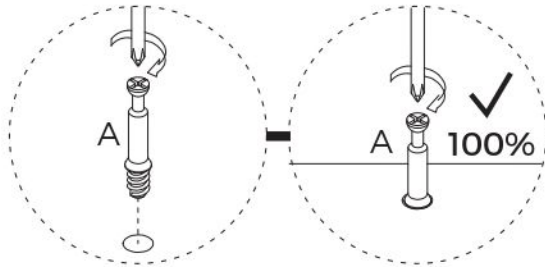

Tighten Part A fully

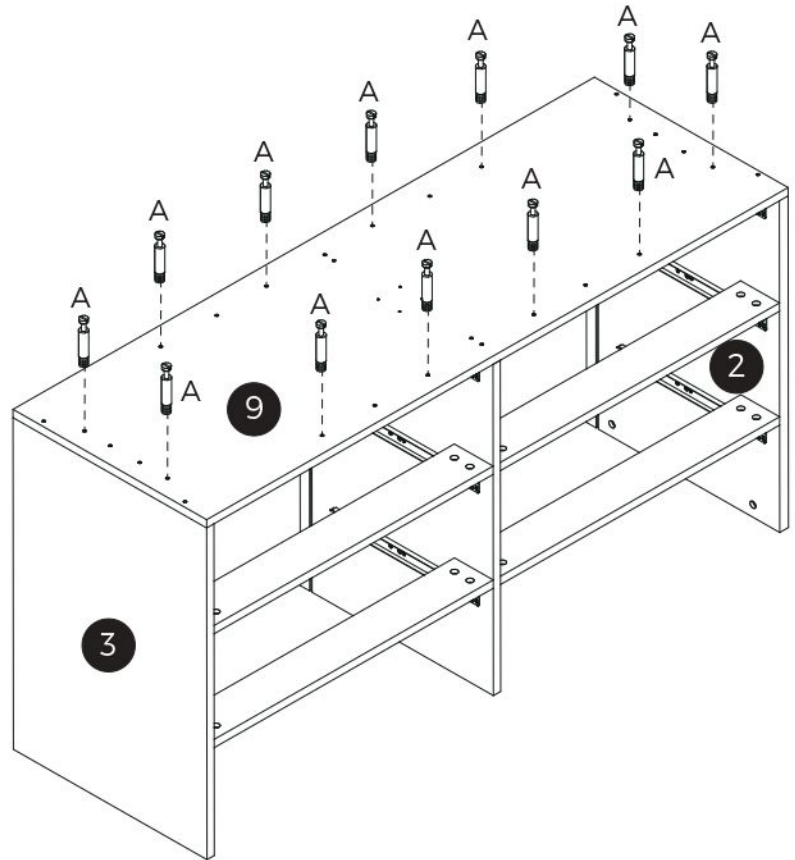

## STEP 12

### Part C

10pcs  
Ø6x30mm

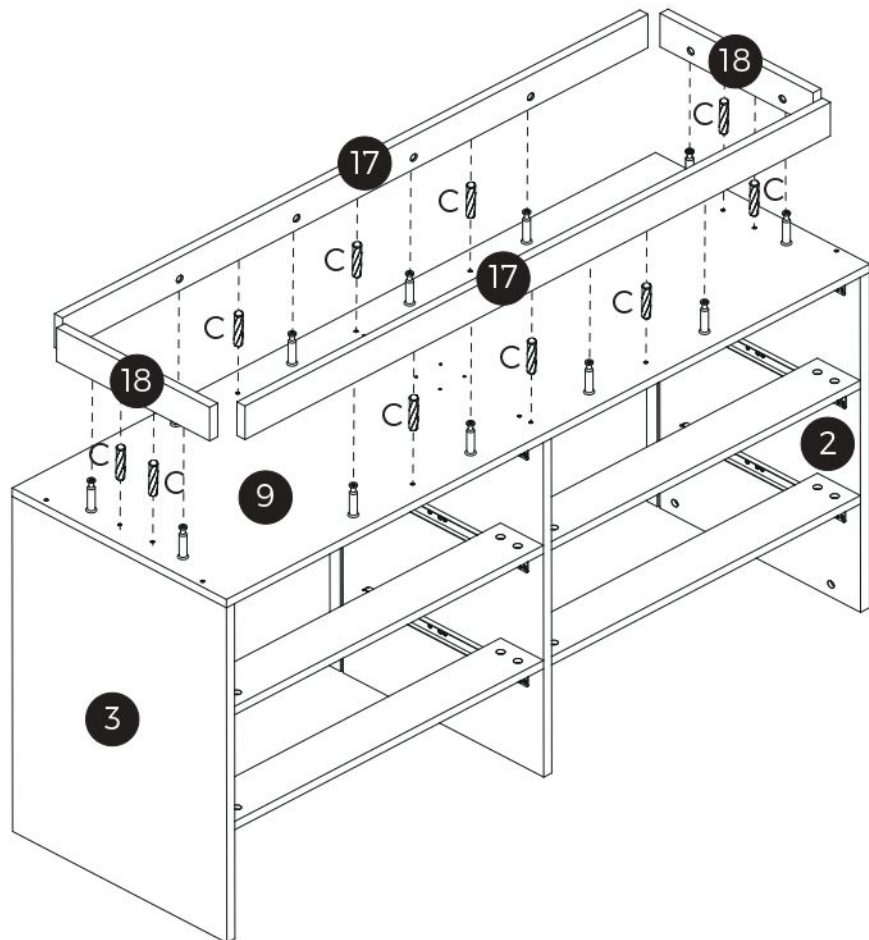

## STEP 13

### Part B

12pcs  
15x9.2mm

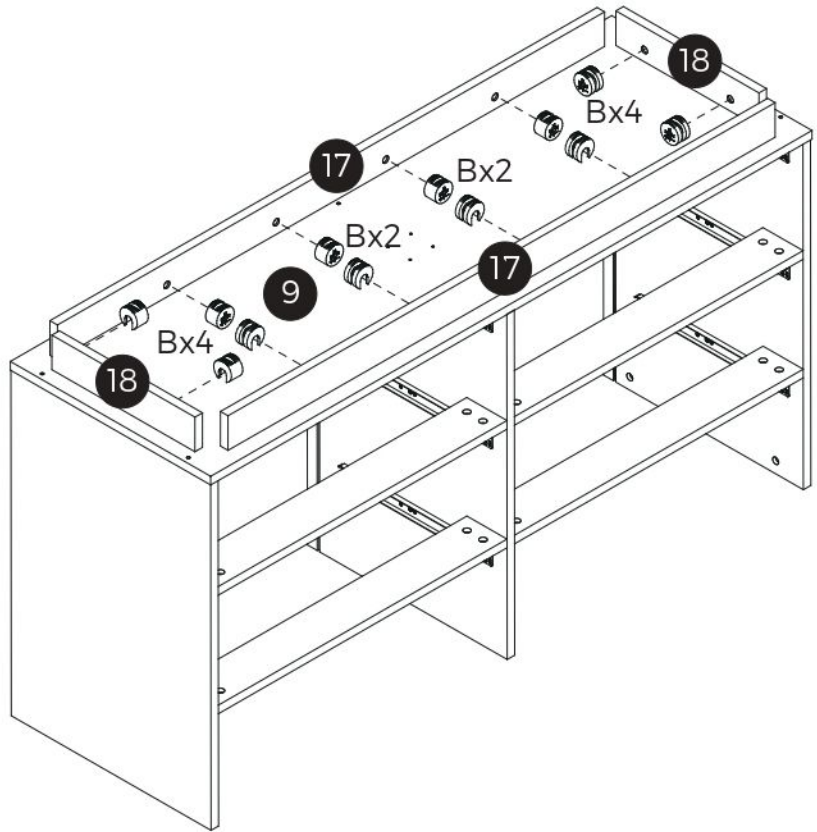
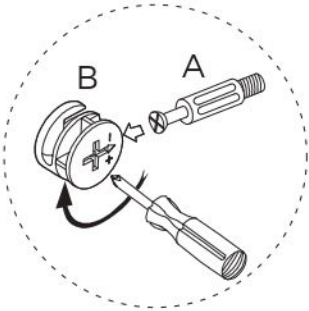

## STEP 14

### Part H

1pc

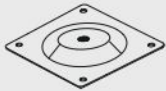

### Part I

4pcs

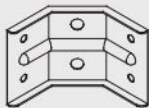

### Part J

20pcs  
Ø4x12mm

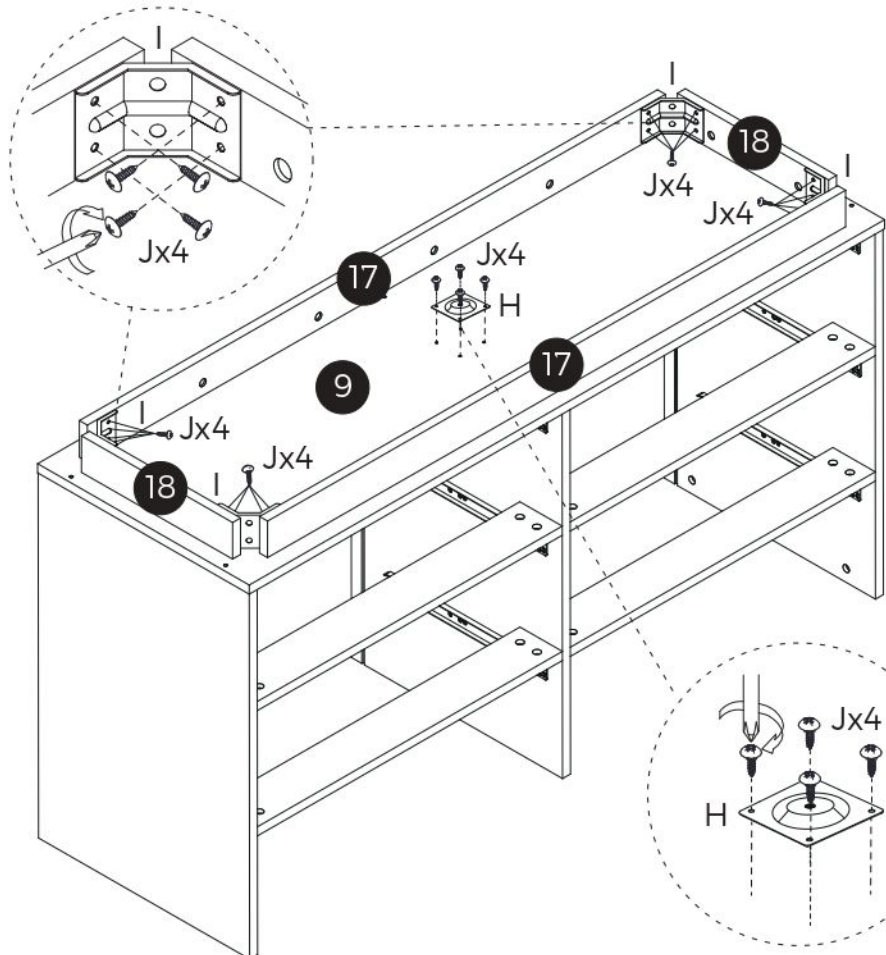

## STEP 15

**Part G**  
1pc



**Part K**  
8 sets  
Ø6x40mm



**Part Q**  
4pcs

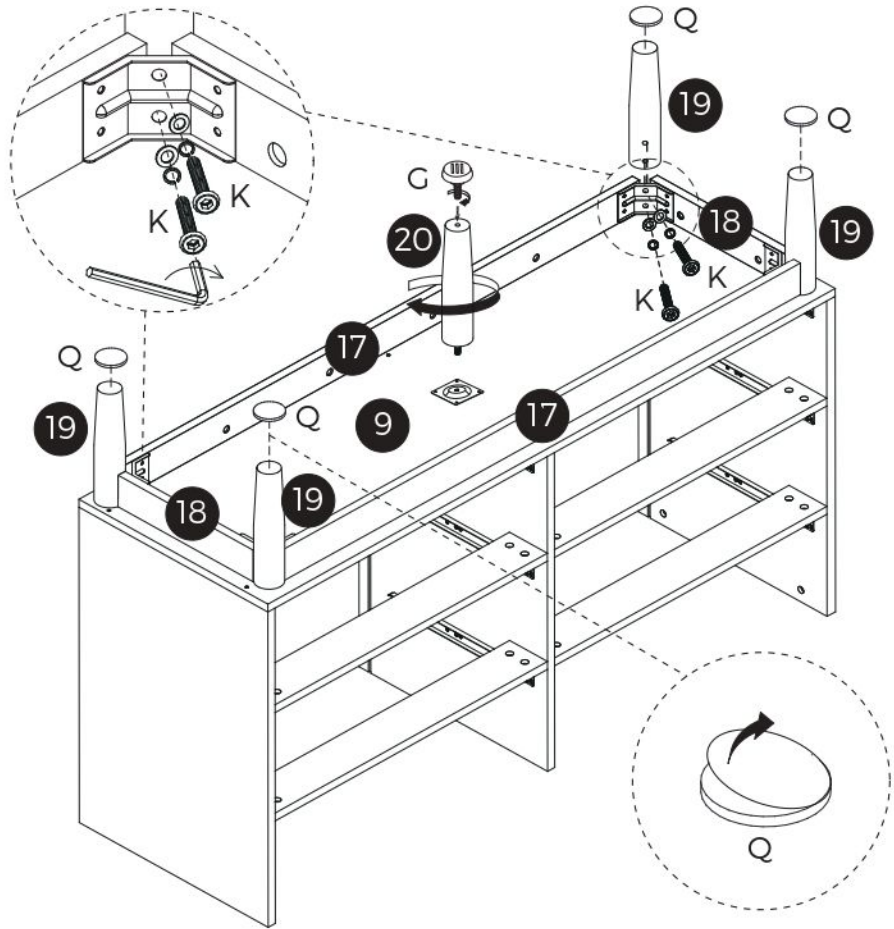

## STEP 16

**Part C**  
6pcs  
Ø6x30mm

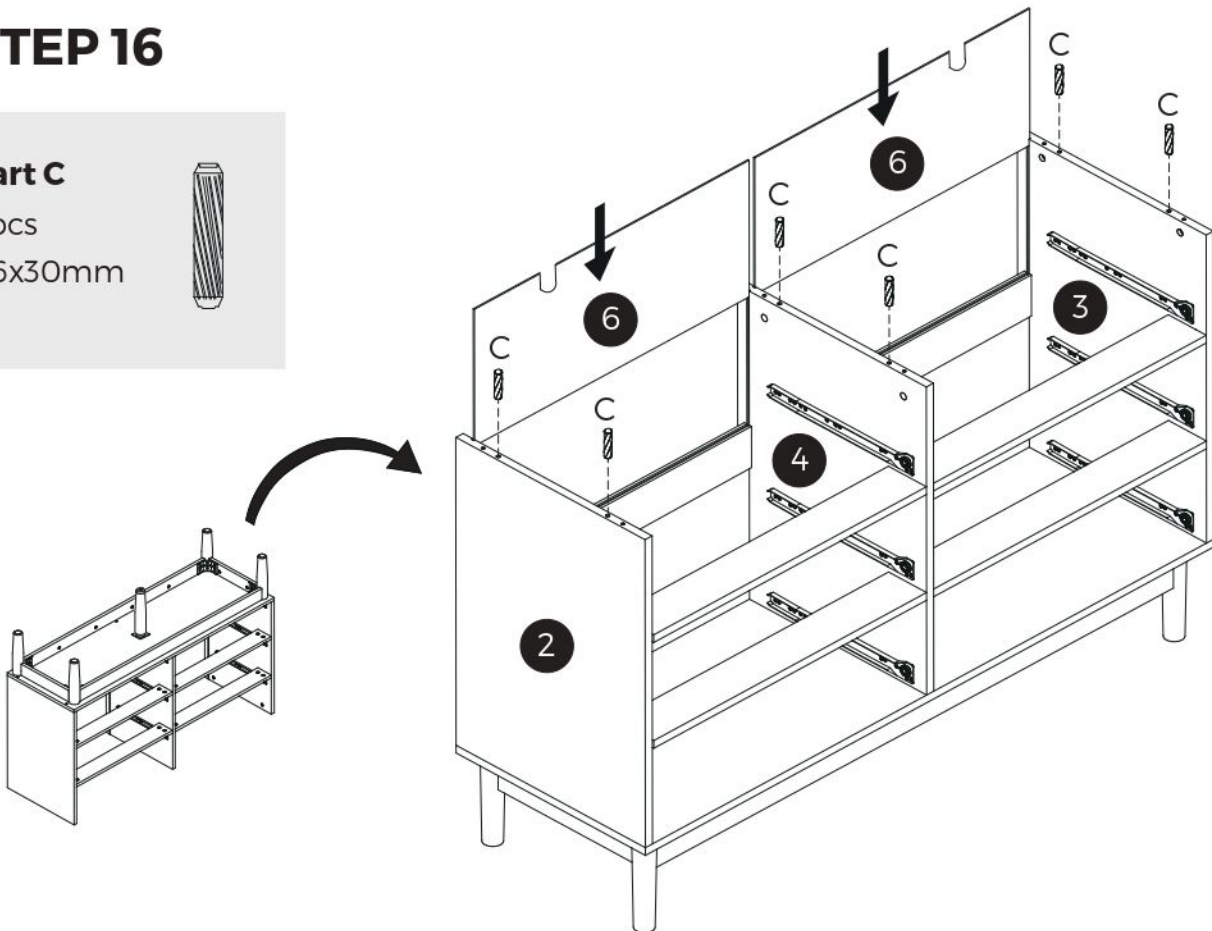

# STEP 17

## Part A

6 pcs  
6x35mm



## Part S

2 sets

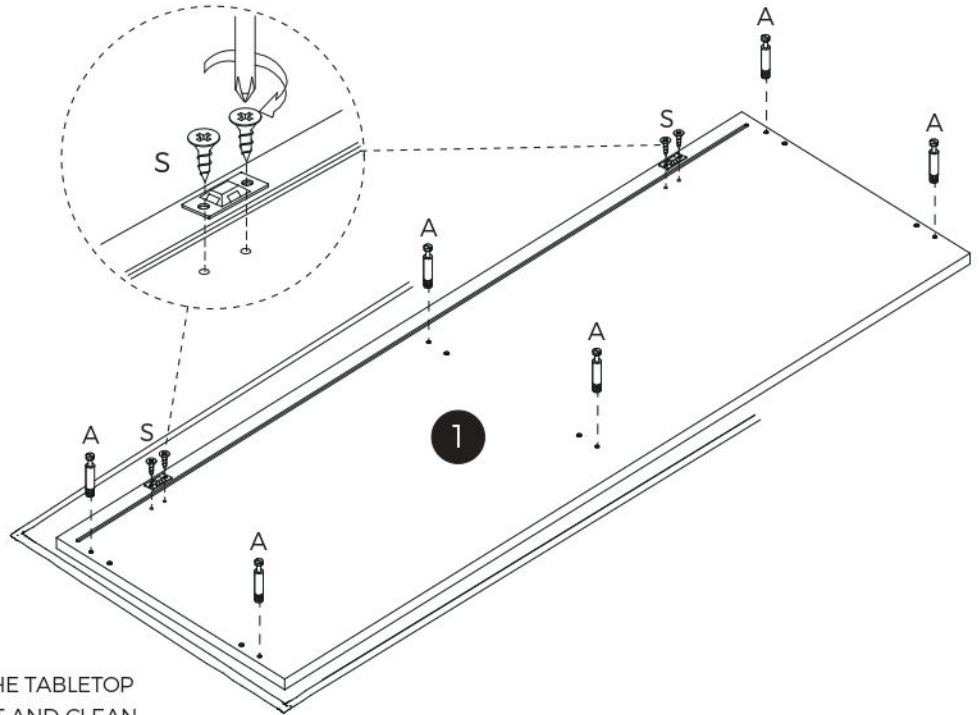
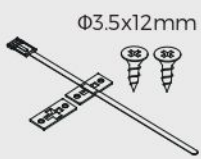

TO AVOID SCRATCHES, THE TABLETOP SHOULD REST ON A SOFT AND CLEAN FABRIC DURING INSTALLATION.

# STEP 18

## Part B

6 pcs  
15x9.2mm

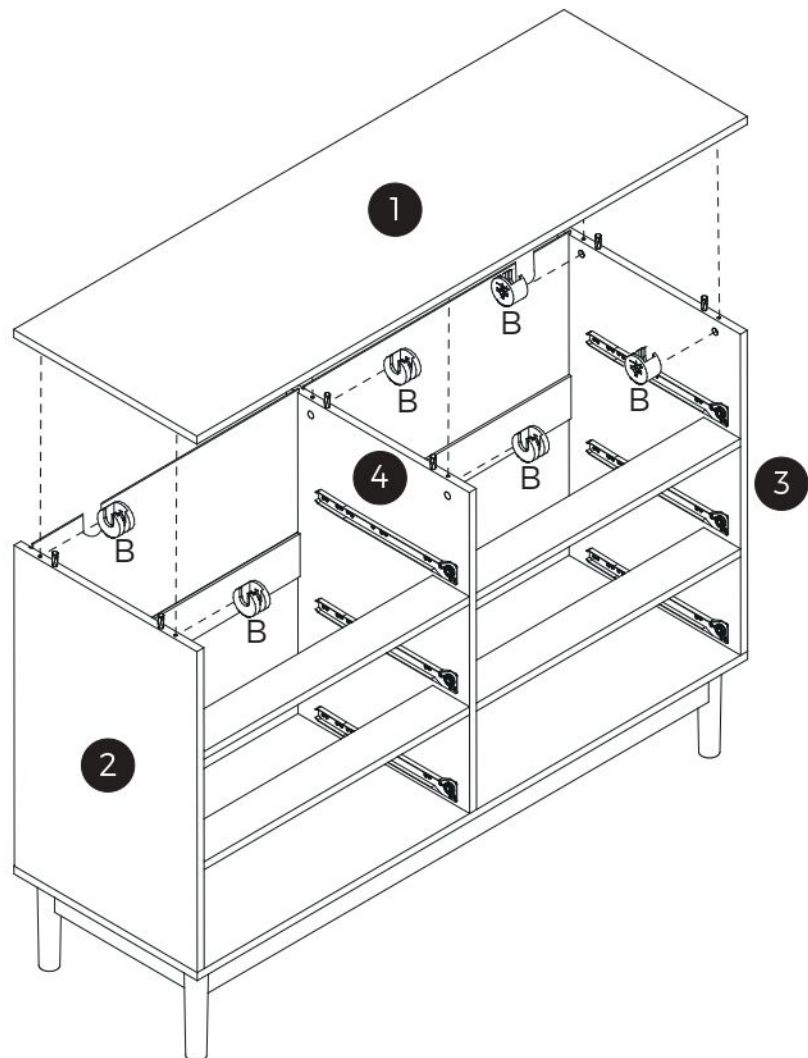
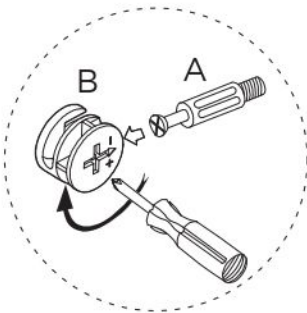

# STEP 19

**Part A**  
10pcs  
6x35mm



**Part B**  
10pcs  
15x9.2mm



**Part D**  
10pcs  
Ø4x35mm



**Part E**  
12pcs  
Ø3x12mm



**Part F**  
2pcs

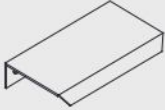

**Part O**  
2pcs

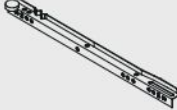

**Part P**  
2pcs

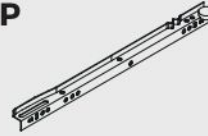

**x2**

Assemble 2 drawers

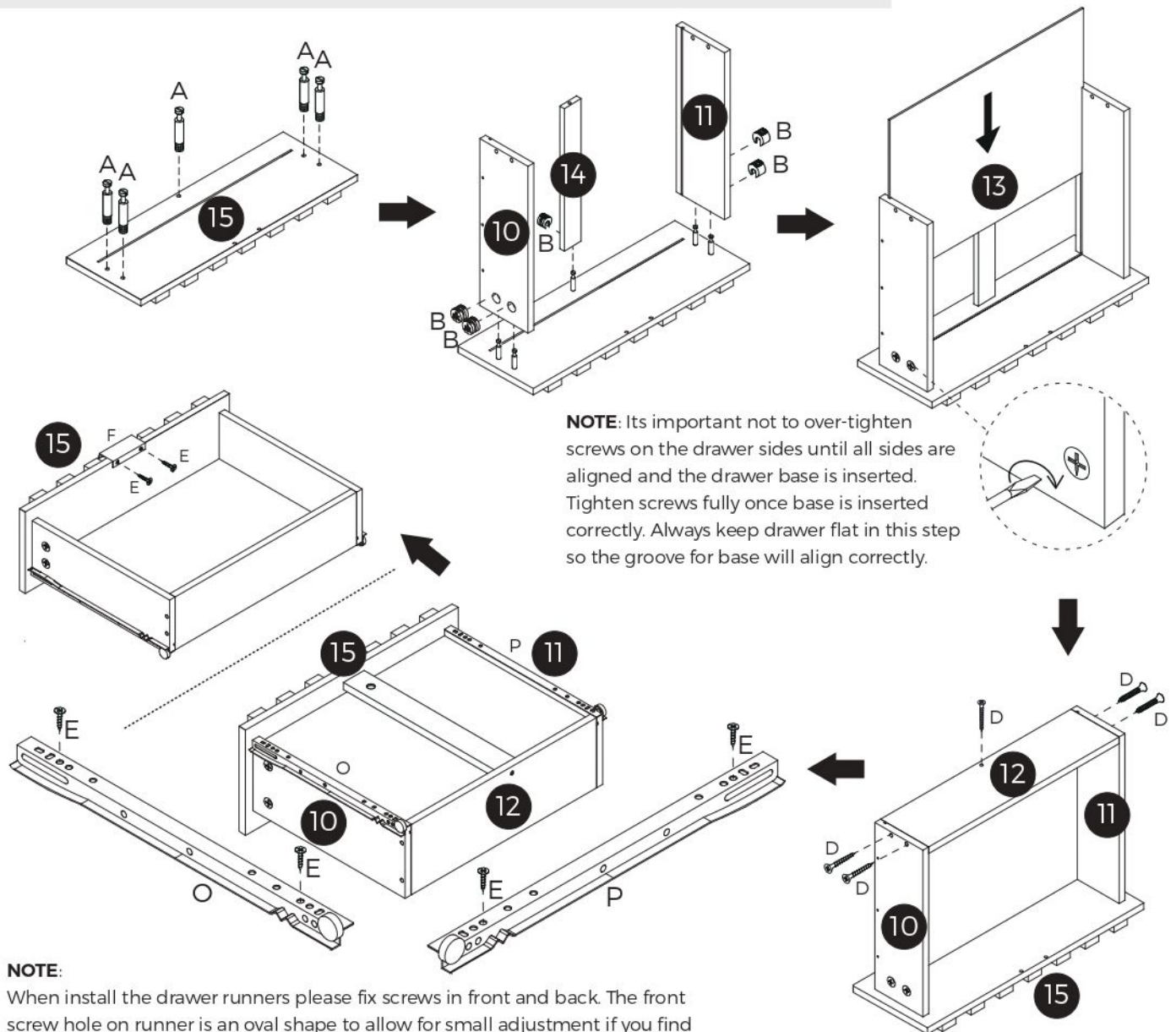

**NOTE:** When install the drawer runners please fix screws in front and back. The front screw hole on runner is an oval shape to allow for small adjustment if you find the gaps between drawers aren't even. **Fix the middle screw after adjustment.**  
**TIP:** It can sometimes take small adjustments to align the drawers correctly.

# STEP 20

**Part A**  
20pcs  
6x35mm



**Part B**  
20pcs  
15x9.2mm



**Part D**  
20pcs  
Ø4x35mm



**Part E**  
24pcs  
Ø3x12mm



**Part F**  
4pcs

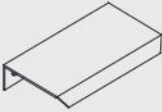

**Part O**  
4pcs



**Part P**  
4pcs

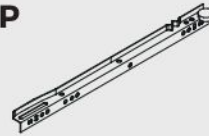

# x4

Assemble 4 drawers

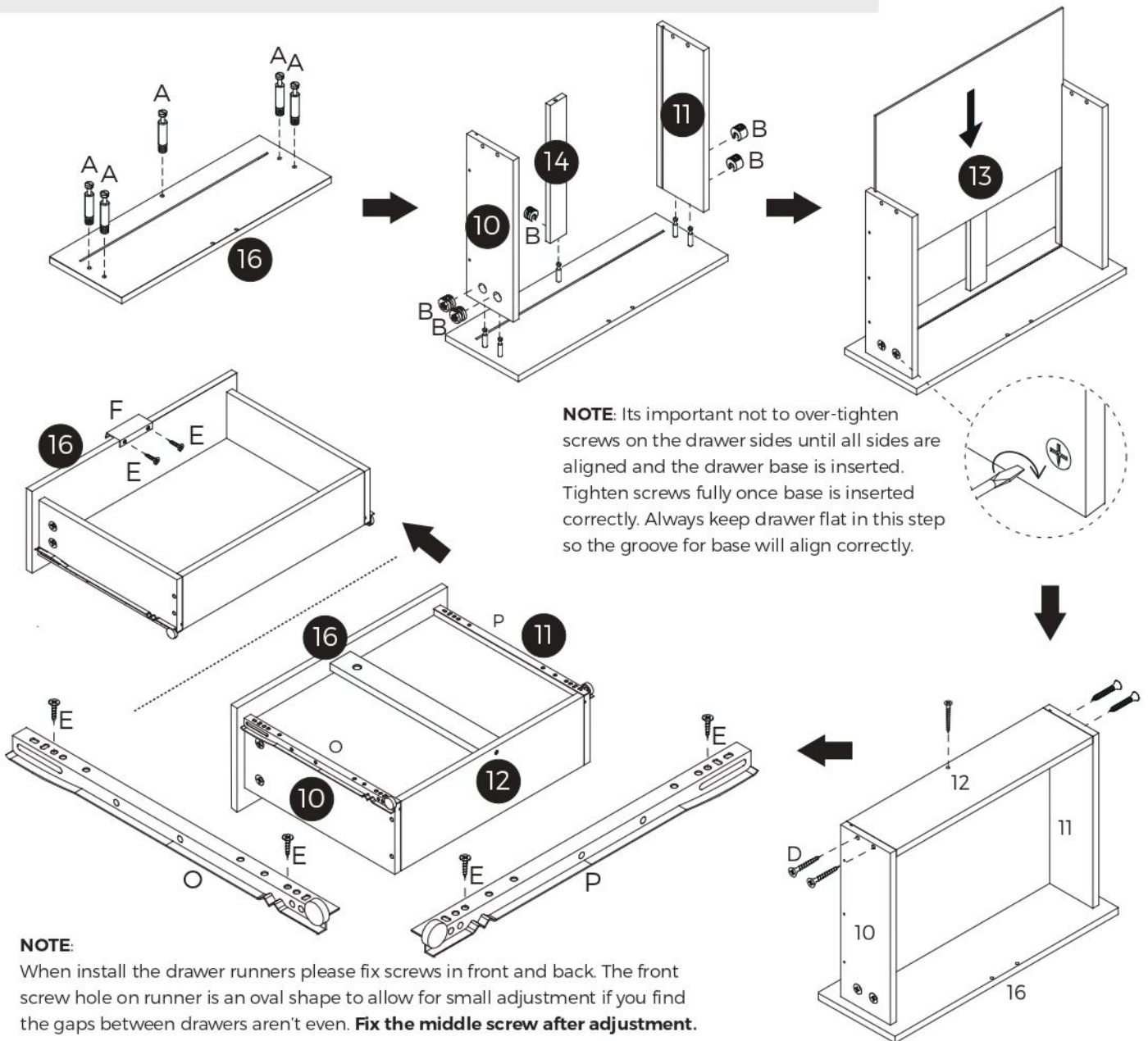

# STEP 21

## Part R

16 sets



Ø3x16mm

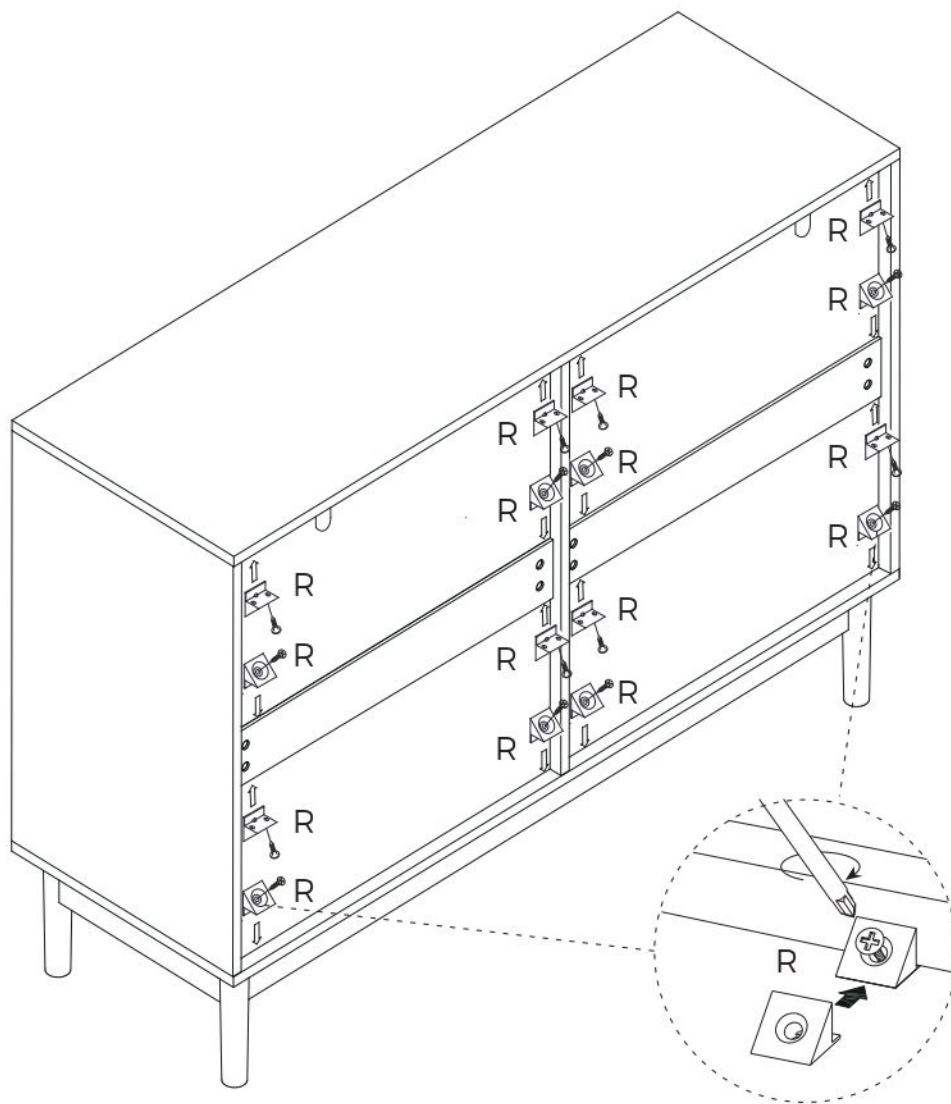

# STEP 22

**Part D**  
4pcs



**Part S**  
2 sets

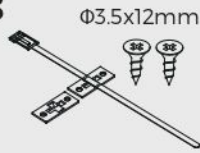

**Part T**  
4pcs



## ⚠ WARNING

It is very important to secure this furniture with an anchoring device for your safety in use.

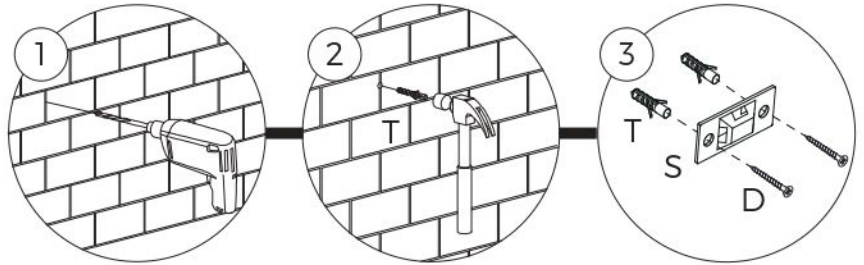

Pre-drill holes in the wall

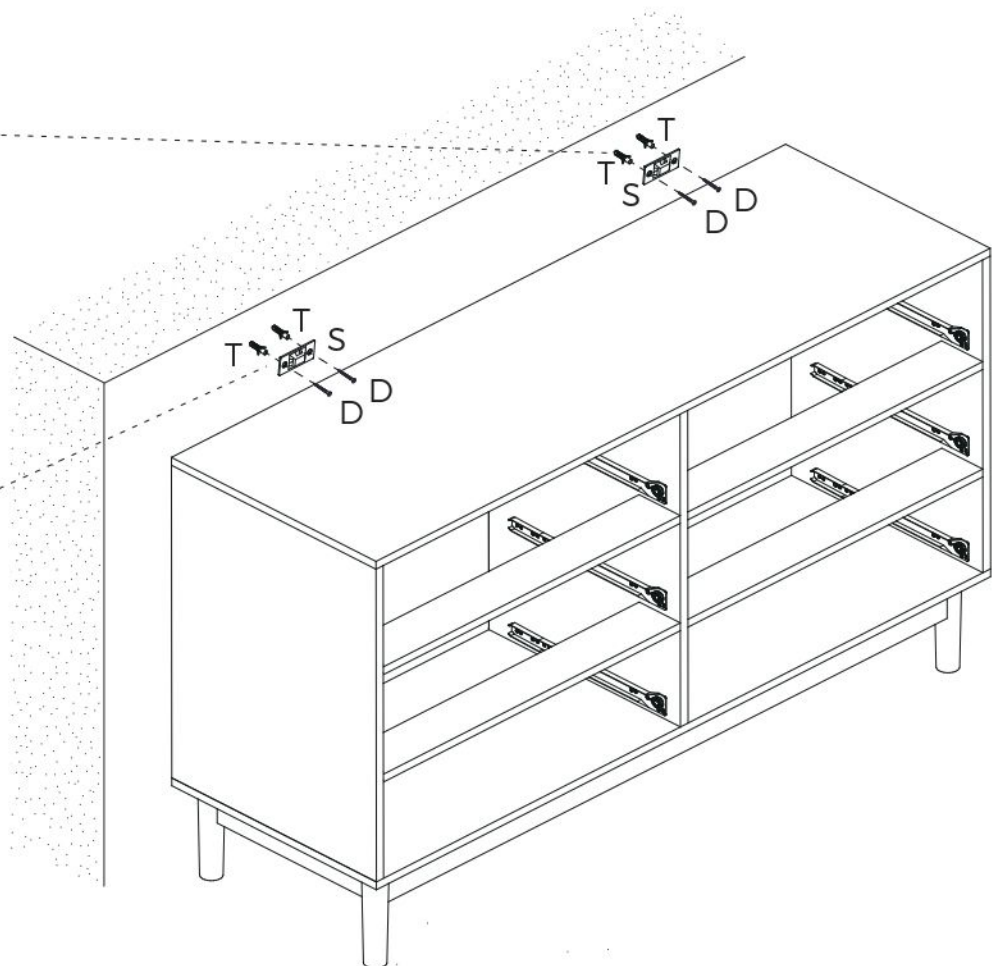
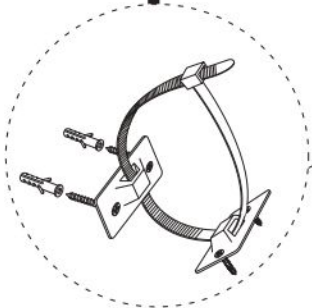
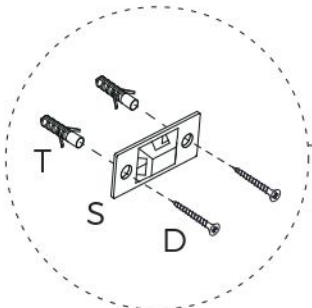

# STEP 23

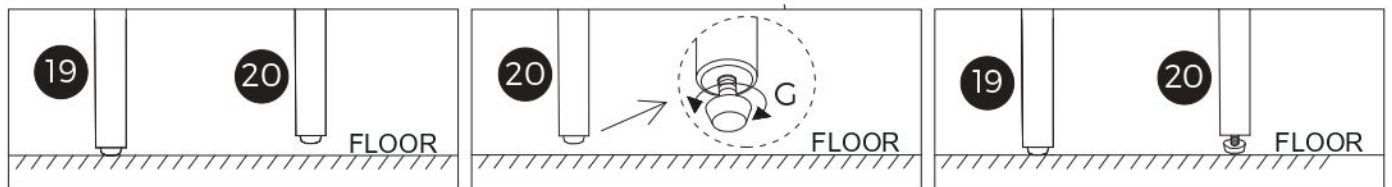
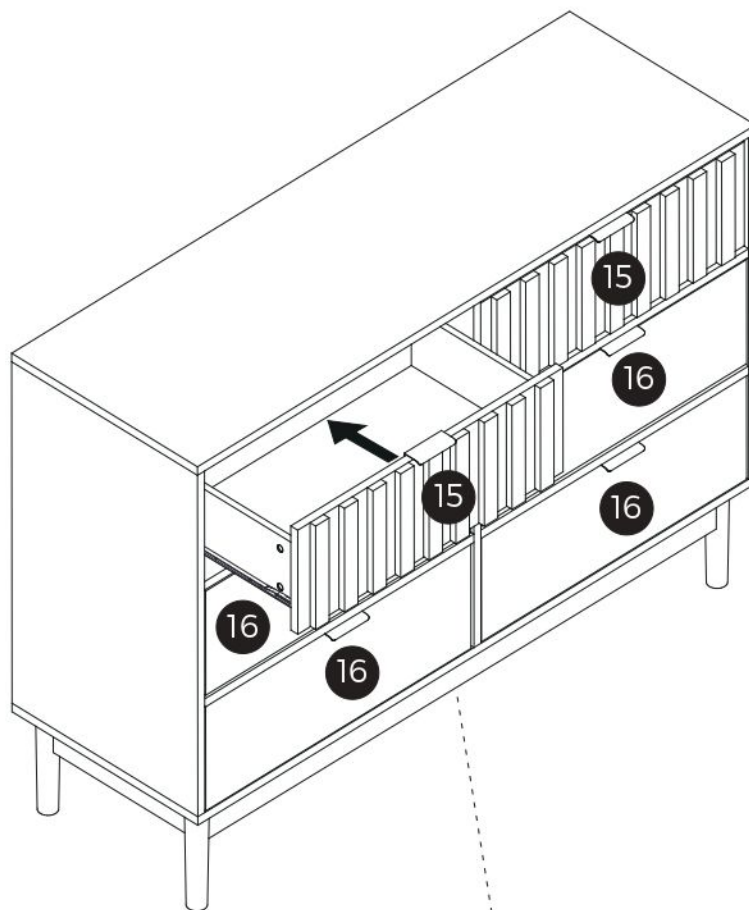

## DRAWER INSTALLATION GUIDE

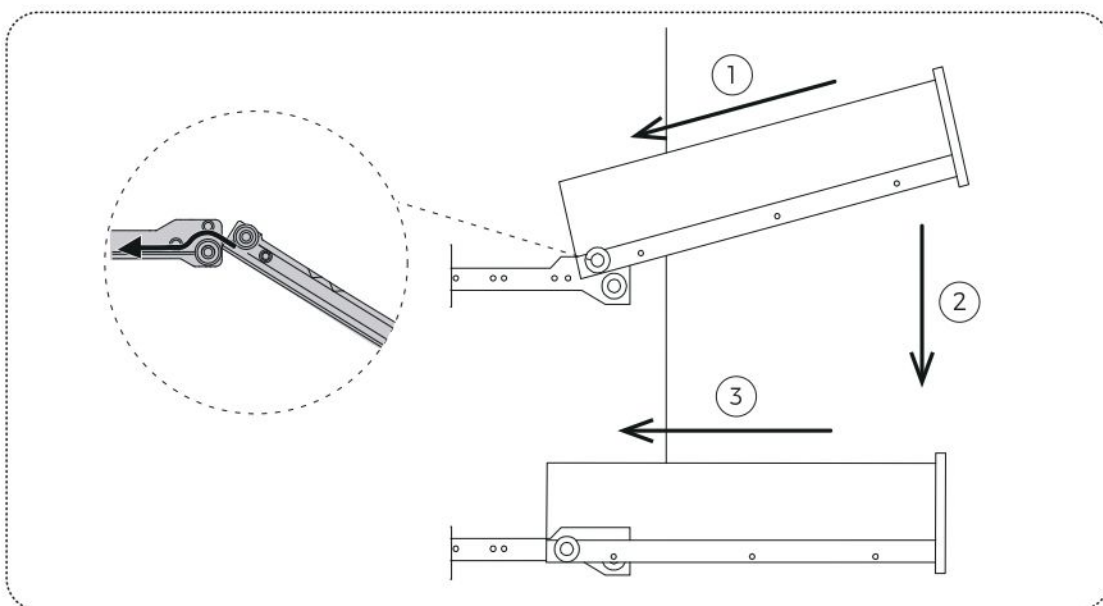

# CARE AND MAINTENANCE

## GENERAL

- Periodically check all screws, bolts and joints connections and tighten them if necessary.
- Periodically check for any damage and deteriorated parts and components and seek repairs or replacements if needed.
- Do not allow any liquids to remain on the furniture as this may cause stains and allow the liquid to be absorbed into the finishes and materials. In some cases, this may also cause warping and/or cracking of the materials and finishes. Use coasters and placemats for all food and beverages.
- Do not place hot items, such as dishes, pots and cups, directly on the furniture. Use coasters and placemats for all food and beverages.
- Keep sharp and pointed objects away from furniture to avoid damaging the surface and finish.
- Do not place the furniture near hot objects, heating vents or heating equipment.
- Do not place the furniture in moist areas, such as bathrooms, to avoid water damage.

## CLEANING AND CARE

- Dust the furniture regularly using a soft cloth or microfibre duster to prevent dust build-up
- Only wipe and clean with a soft, damp cloth with a mild cleaning detergent.
- Do not use abrasive cleaning materials such as scouring pads and chemical cleaning solvents to avoid damage to finishes and paintwork.
- After using or cleaning a glass table top, wipe it completely dry as leaving the glass unattended when wet may leave water marks that cannot be removed easily.
- For upholstery, vacuum regularly with a soft, non-metallic brush to remove dust and grime and to prevent overall soiling. Follow manufacturer's instructions for spot cleaning.
- If removable, wash upholstery covers periodically. If machine washable, use a cold wash cycle.
- Do not use a dryer. Only air dry the upholstery covers.

## ENVIRONMENTAL

- Do not expose the furniture (including outdoor furniture) to direct sunlight. Protect your outdoor furniture with weather-resistant covers, and have curtains and blinds to shield indoor furniture if direct sunlight is unavoidable.
- Bamboo, rattan as well as wood-based furniture are prone to damage and fade with prolonged exposure to extremely high or low humidity conditions. Do not place them in such extreme conditions.
- For outdoor bamboo/rattan furniture, do not place the furniture in shady or moist areas to prevent it from moulding. Bring the furniture indoors during the off season or covered it with weather-resistant covers.

## HANDLING

- Do not drag, push or pull furniture when moving them. Lift them up to avoid damage to the furniture legs and scratches on floors.
- Do not sit or stand on the armrests or use the furniture as a stepping stool for safety reasons.
- Do not exceed the recommended weight capacities of the furniture specified.
- Do not use the furniture for any other purpose other than what is intended for.

## STORAGE

- Store furniture in a clean, dry environment when not in use.
- If possible, disassemble furniture before storing to save space and prevent damage during transportation.