

ASSEMBLY INSTRUCTIONS

Please read the instructions carefully before assembly and keep it for future reference.

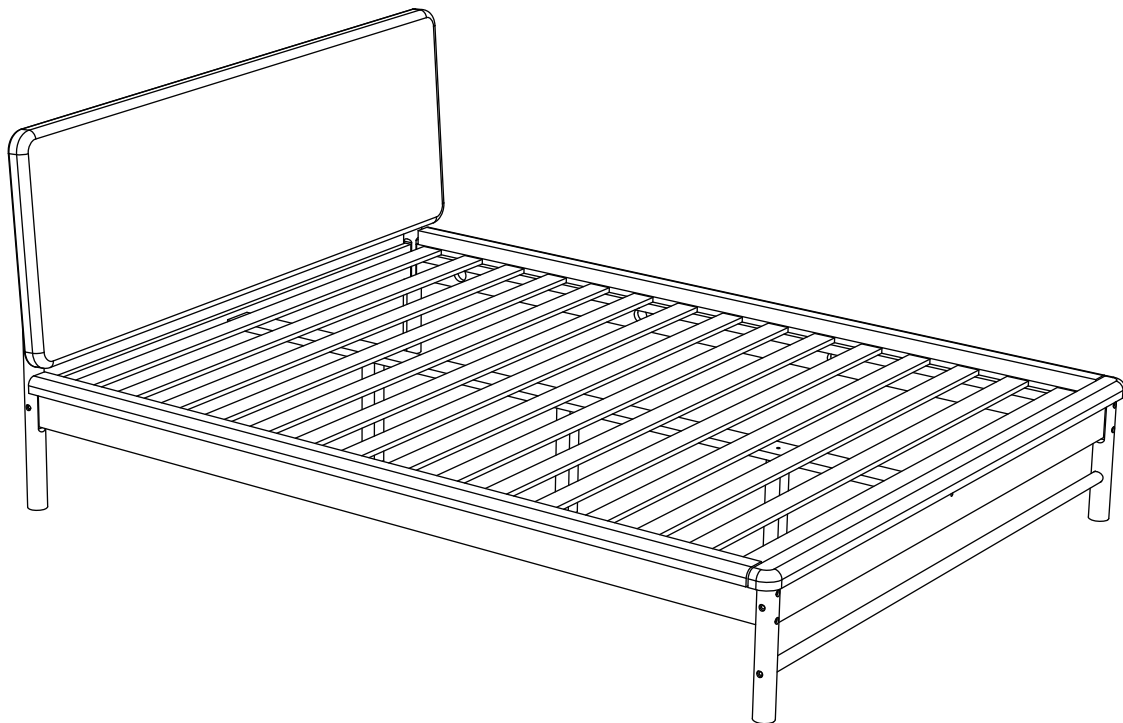
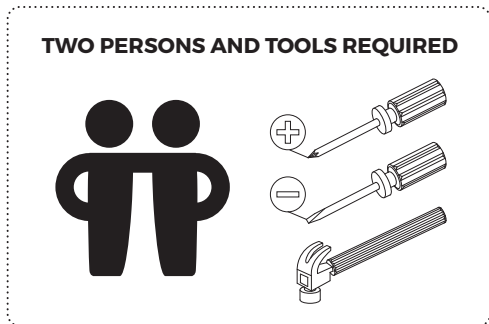

BED FRAME

Model : BF-W-B-IRIS-Q

Version 1.0

Assembly and Maintenance Tips



1. Keep children and pets away from the working area as small parts may cause choking if swallowed.



2. Some furniture may require two persons to assemble for safety reasons.

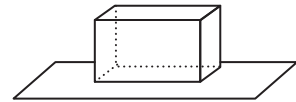

3. To protect the surfaces of the furniture, lay the parts and perform the assembly on top of a soft mat (such as a carpet or cardboard).

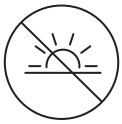

4. Keep the furniture away from direct sunlight to avoid fading.



5. Use a soft, damp cloth to clean or wipe surfaces.



6. Never use ammonia-based or abrasive cleaning products to clean as they may damage the finish.



7. Do not place liquids or wet items on furniture as they may leave water marks/stains. Always use a coaster or runner to protect the furniture surface.

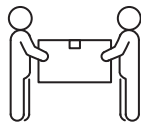

8. When moving the bed frame, please lift it up with two persons to help move it. Do not drag, push or pull the bed frame as these actions may damage the bed frame legs.

Assembly Checklist

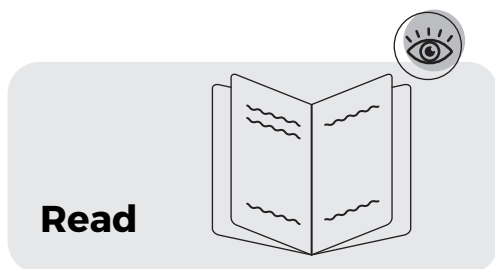

Read

Read through the instructions carefully before you begin.

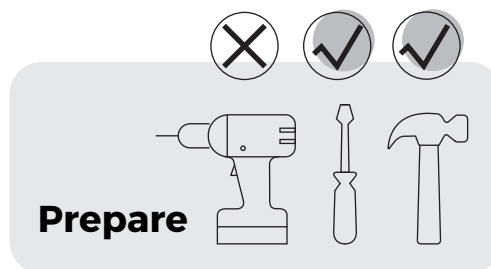

Prepare

Make sure you have all the required tools. Never use power tools unless instructed.

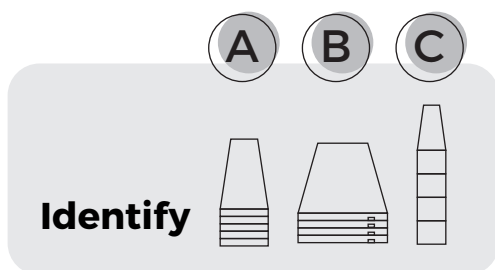

Identify

Identify and lay out all of the components before you begin assembly.

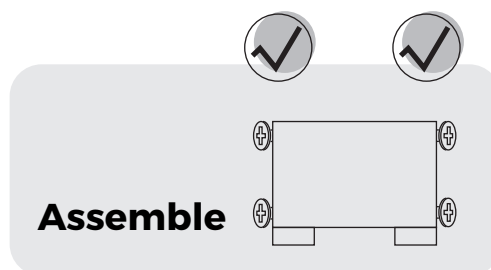

Assemble









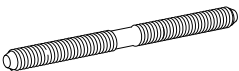
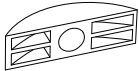
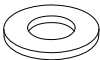

Please fully tighten all screws during the assembly process unless instructed not to do so.

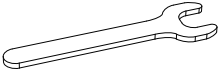
Helpful Information

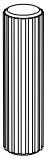
- ! Never use power tools unless specifically instructed. They can damage your components or hardware if used incorrectly.
- ! The most common mistakes made during assembly are using the wrong hardware or getting components back to front.
- ! When assembling the product, it is recommended to do so on top of a soft surface such as a carpet or cardboard to avoid scratches and damages to the furniture surfaces.
- ! Bulky items such as wardrobes should be assembled in the location when the assembled piece will be used to avoid moving them through doors or tight passages.
- ! Never use any glue until you are certain that the parts belong together.
- ! Periodically check that all connections are secured and follow all care and maintenance instructions stated.
- ! If you encounter any assembly difficulties or missing components and/or hardware, please contact our Customer Service for further assistance.

Hardware List

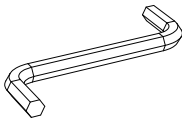
Please ensure that all parts and hardware are in the packaging contents. If there are any missing parts and/or hardware, please contact our Customer Service as soon as possible.

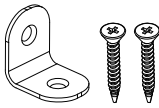
<p>Part A 11pcs M6x80mm</p> 	<p>Part B 11pcs</p> 	<p>Part C 11pcs</p> 	<p>Part D 11pcs</p> 
<p>Part E 1pc</p> 	<p>Part F 14pcs</p> 	<p>Part G 16pcs M8x30mm</p> 	<p>Part H 12pcs M6x80mm</p> 
<p>Part J 4pcs M6x60mm</p> 	<p>Part K 2pcs M6x45mm</p> 	<p>Part L 30pcs Ø4x30mm</p> 	<p>Part M 1pc</p> 
<p>Part N 5pcs Ø6x70mm</p> 	<p>Part P 6 sets</p> 		

Parts

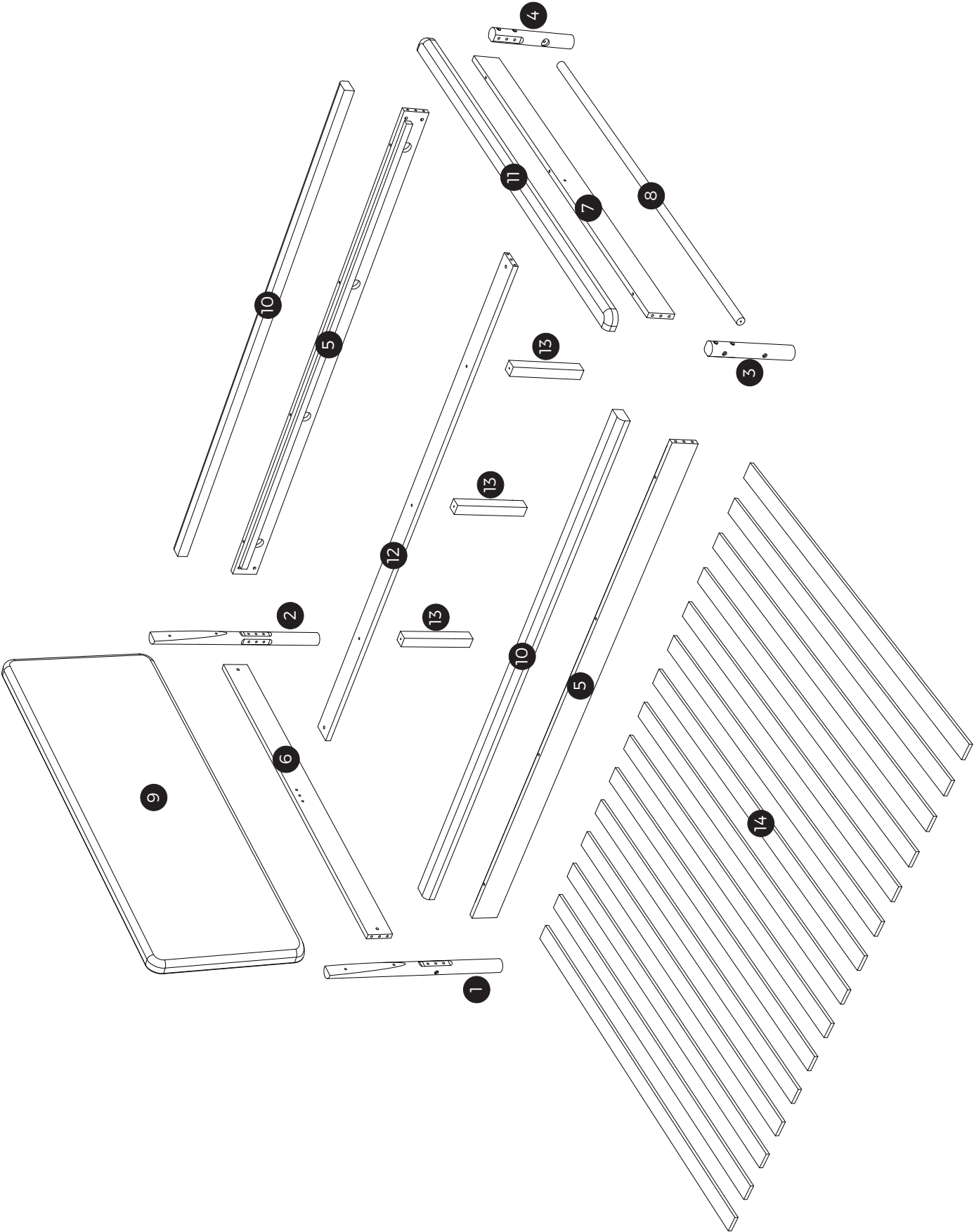

STEP 1

Part A

11pcs

M6x80mm

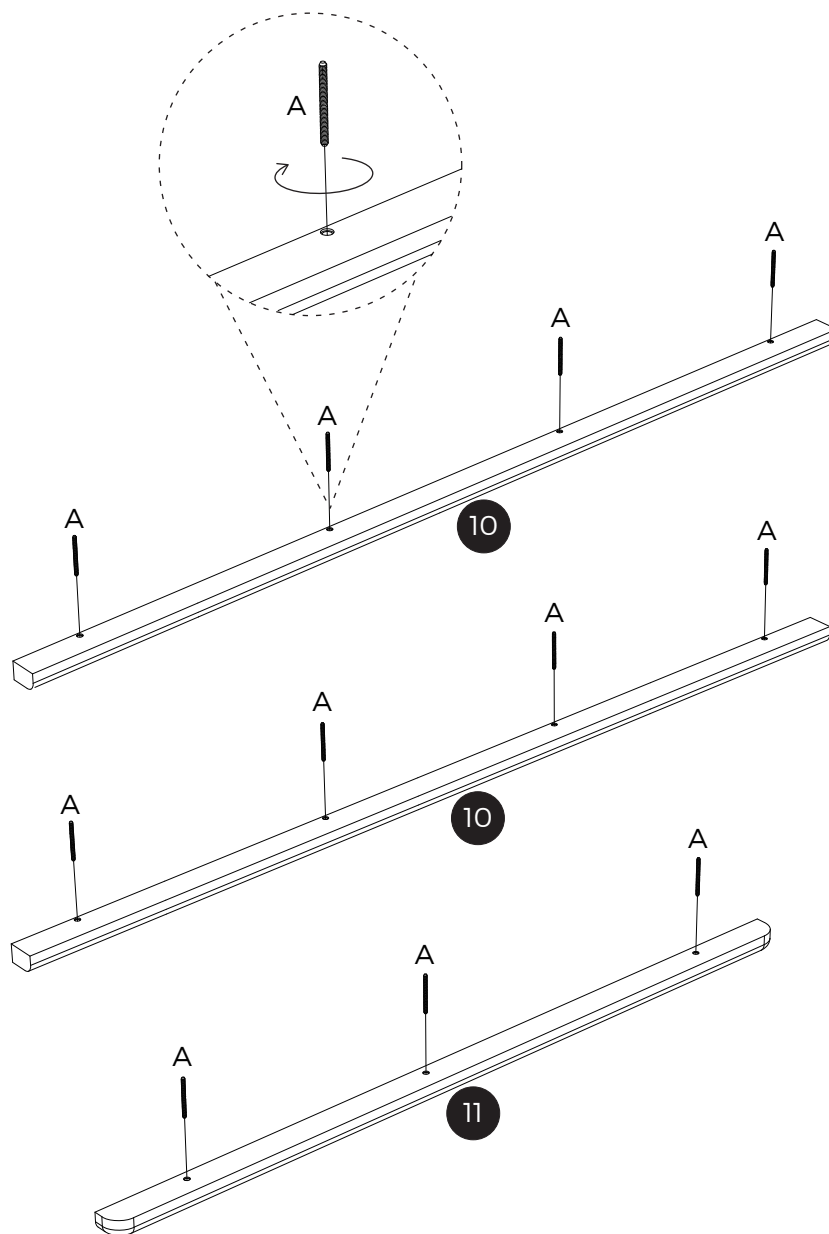
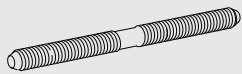

STEP 2

Part B
8pcs

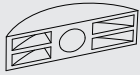

Part C
8pcs

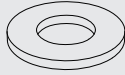

Part D
8pcs

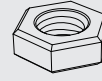

Part E
1pc



Part P
6 sets

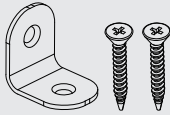

x2

Assemble 2 sets

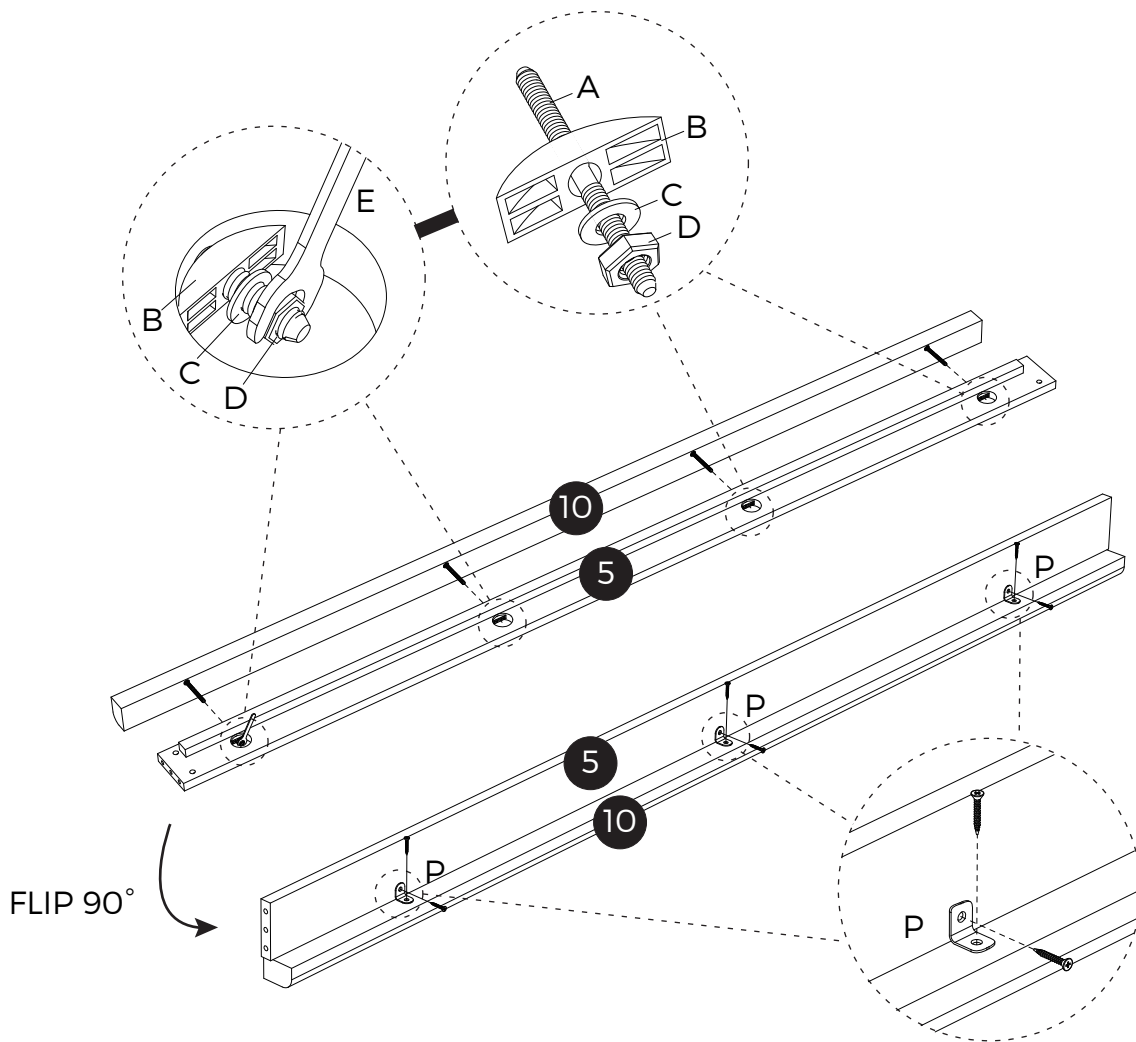

FLIP 90°

STEP 3

Part F
2pcs



Part G
4pcs
M8x30mm



Part H
2pcs
M6x80mm



Part N
2pcs
Φ6x70mm

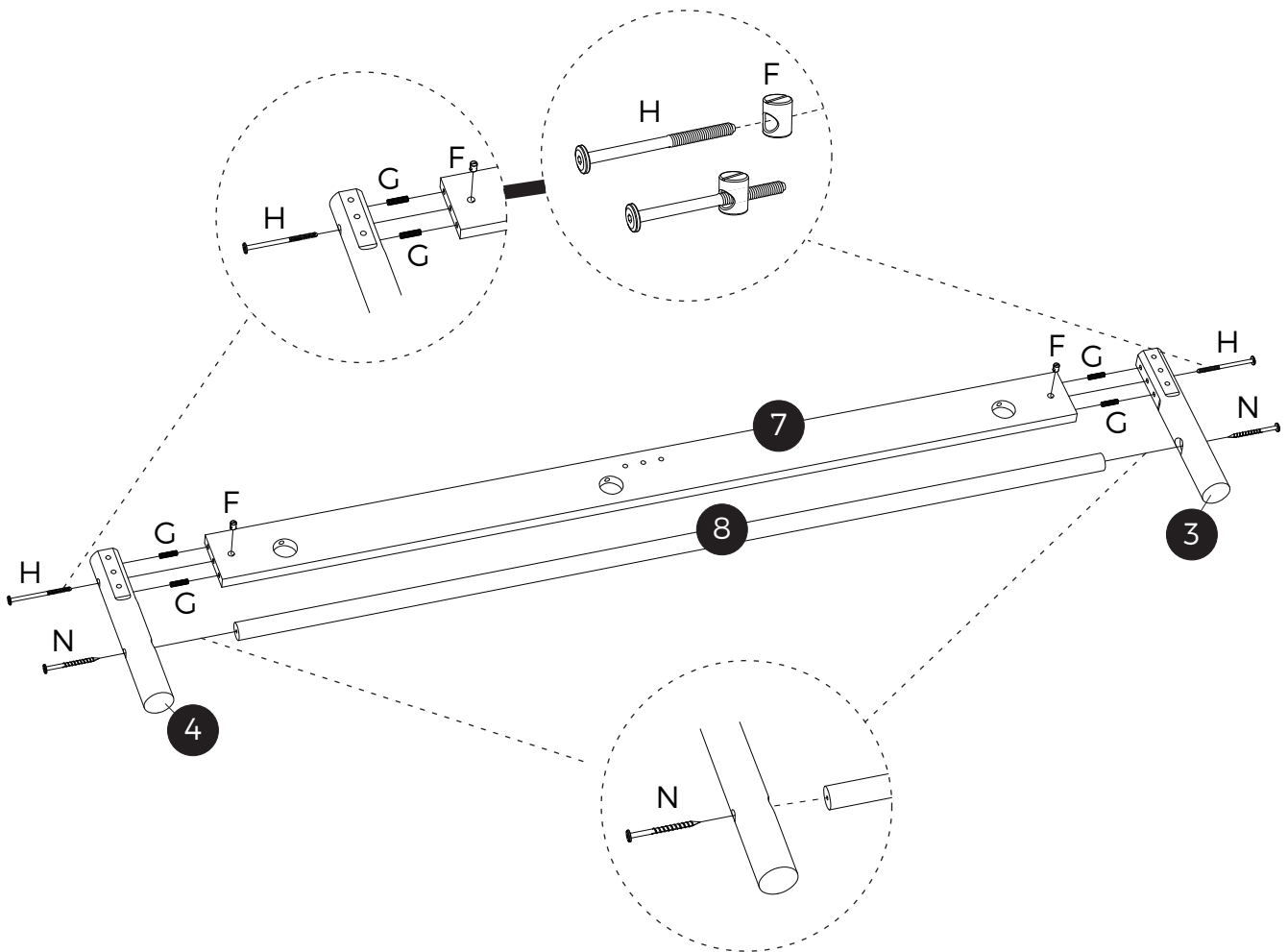

STEP 4

Part B
3pcs

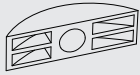

Part C
3pcs

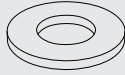

Part D
3pcs

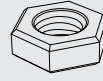

Part E
1pc

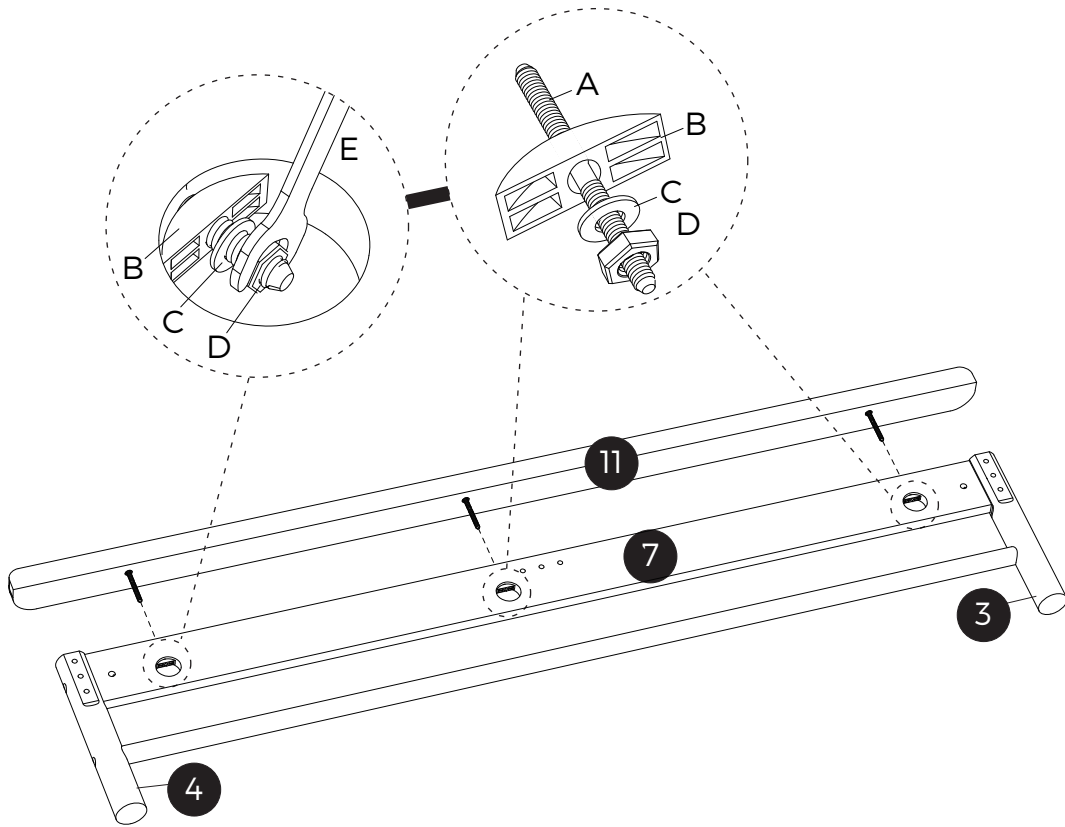

STEP 5

Part F
2pcs



Part G
4pcs
M8x30mm



Part H
2pcs
M6x80mm

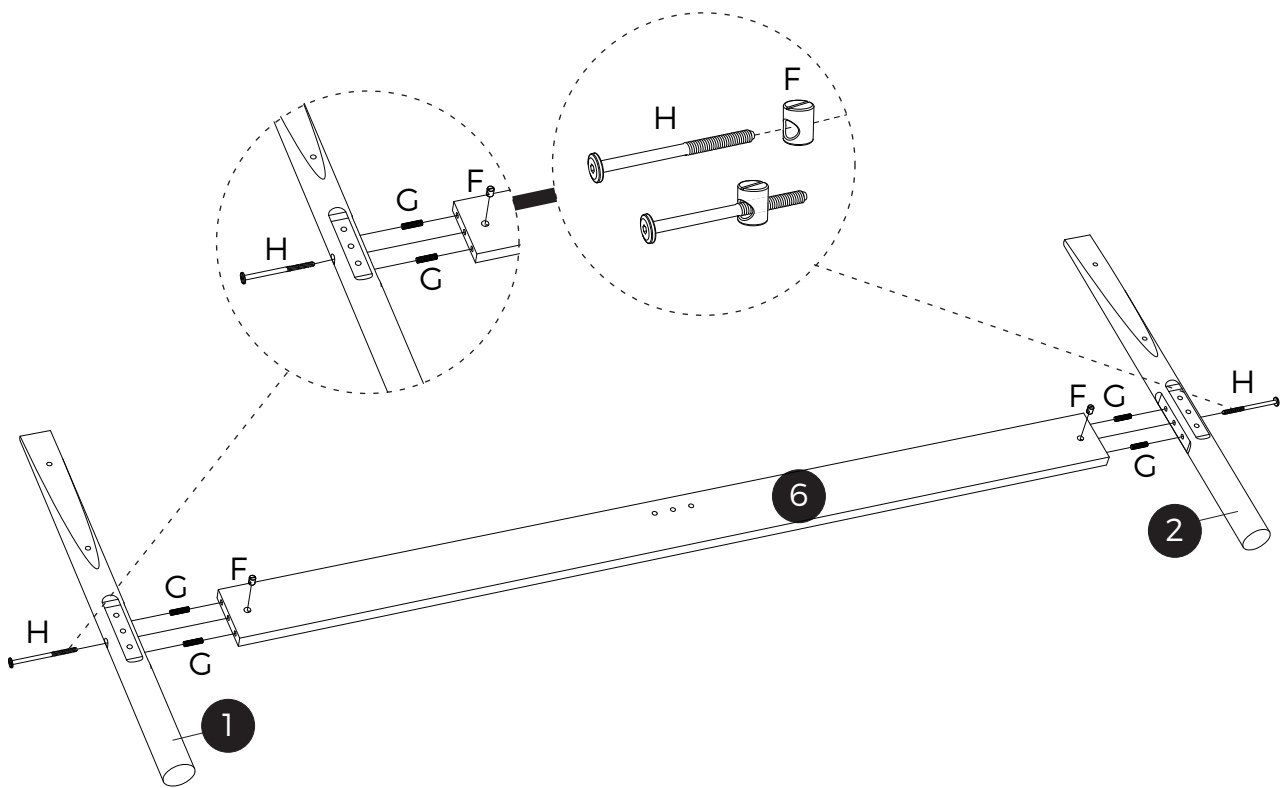

STEP 6

Part F

10pcs



Part G

8pcs

M8x30mm



Part H

8pcs

M6x80mm



Part J

2pcs

M6x60mm



Part N

3pcs

Ø6x70mm

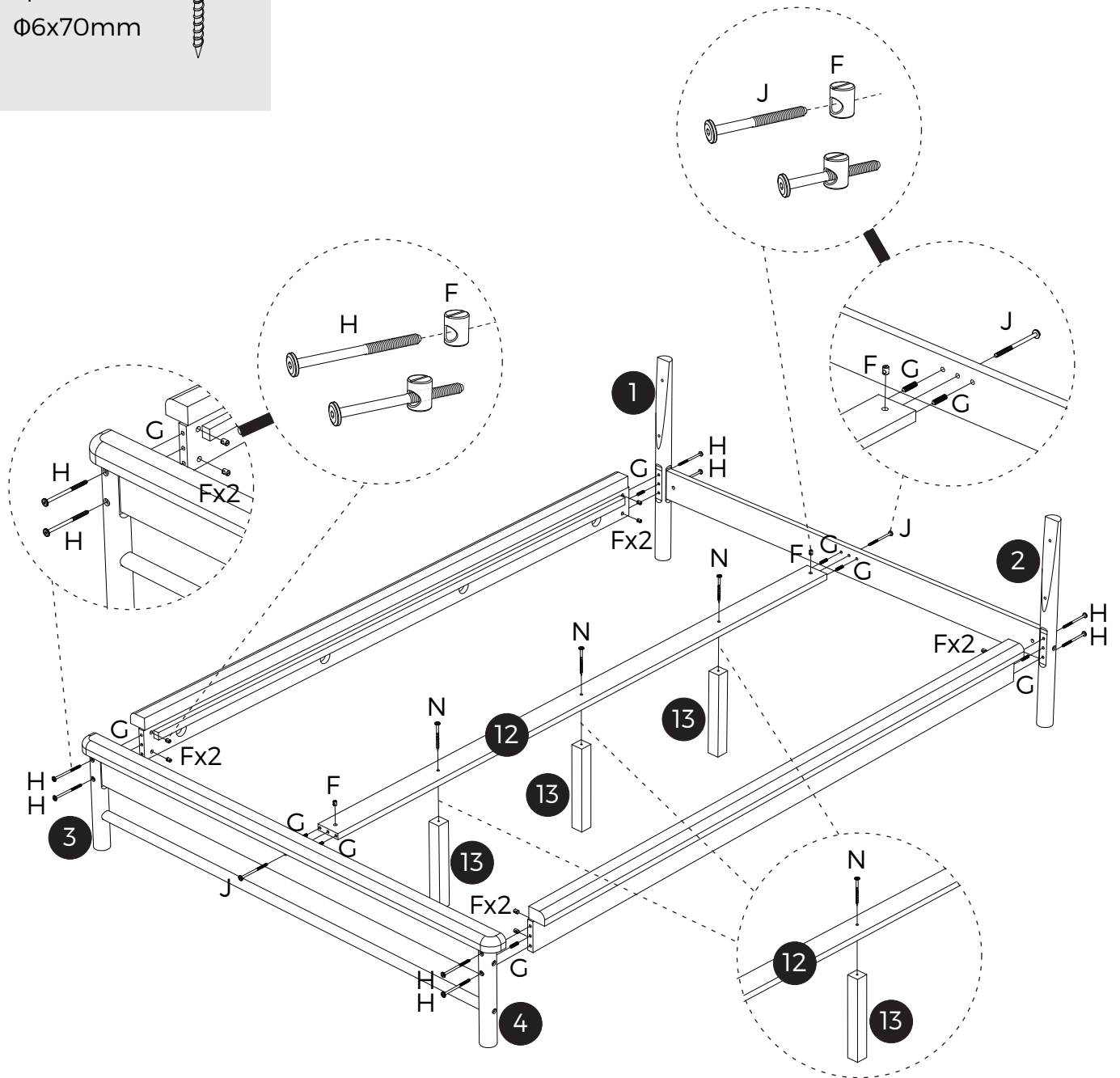

STEP 7

Part J

2pcs
M6x60mm



Part K

2pcs
M6x45mm

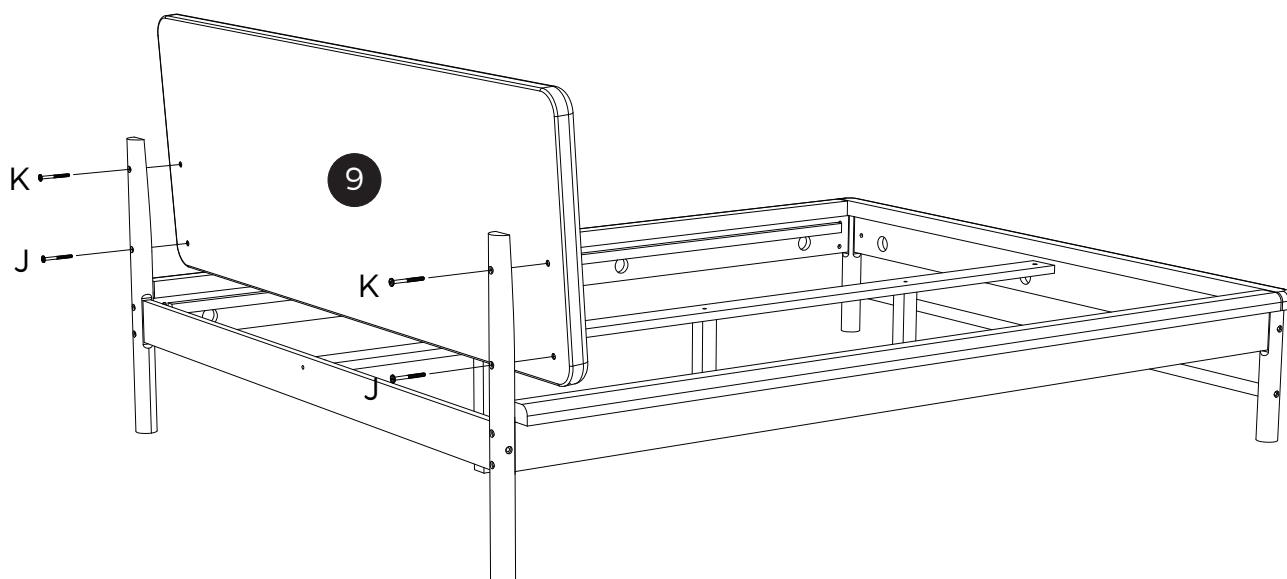

STEP 8

Part L

30pcs
Ø4x30mm

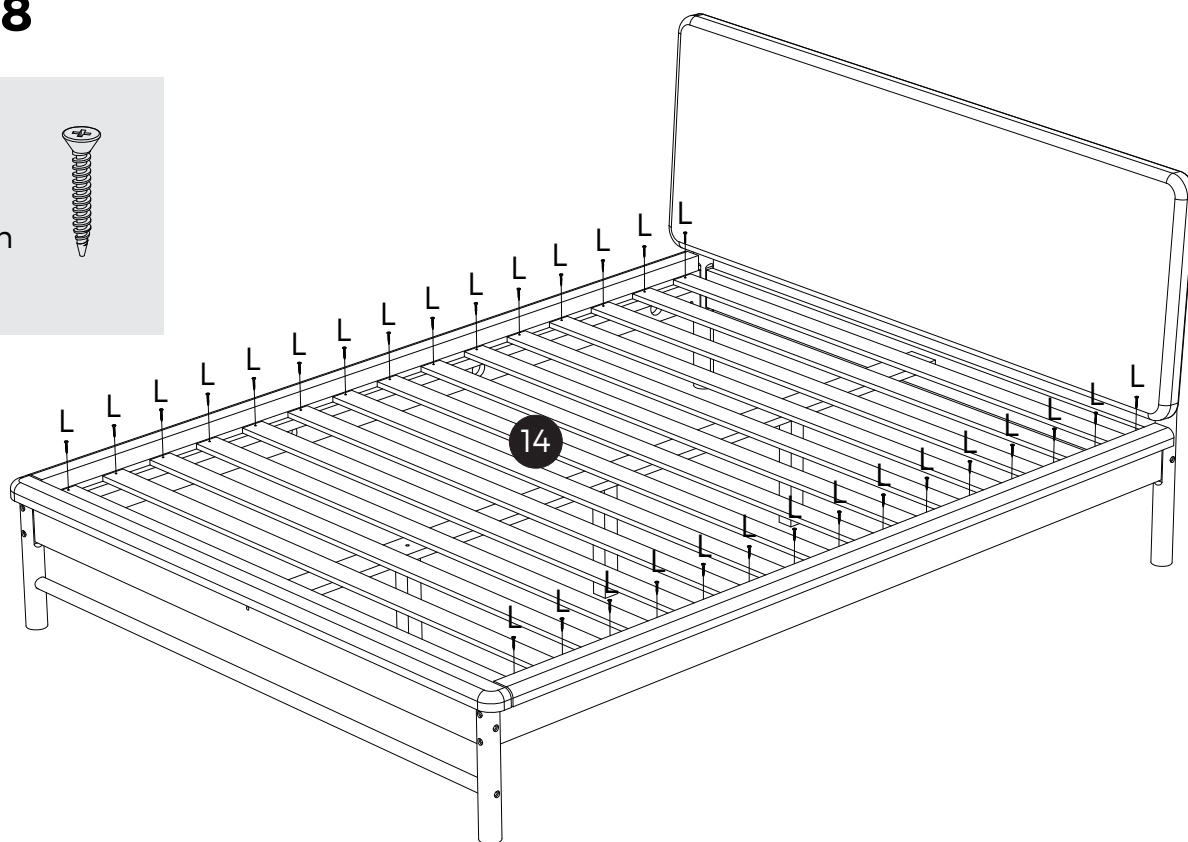
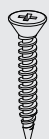

CARE AND MAINTENANCE - FURNITURE

GENERAL

- Periodically check all screws, bolts and joints connections and tighten them if necessary.
- Periodically check for any damage and deteriorated parts and components and seek repairs or replacements if needed.
- Do not allow any liquids to remain on the furniture as this may cause stains and allow the liquid to be absorbed into the finishes and materials. In some cases, this may also cause warping and/or cracking of the materials and finishes. Use coasters and placemats for all food and beverages.
- Do not place hot items, such as dishes, pots and cups, directly on the furniture. Use coasters and placemats for all food and beverages.
- Keep sharp and pointed objects away from furniture to avoid damaging the surface and finish.
- Do not place the furniture near hot objects, heating vents or heating equipment.
- Do not place the furniture in moist areas, such as bathrooms, to avoid water damage.

CLEANING AND CARE

- Dust the furniture regularly using a soft cloth or microfibre duster to prevent dust build-up
- Only wipe and clean with a soft, damp cloth with a mild cleaning detergent.
- Do not use abrasive cleaning materials such as scouring pads and chemical cleaning solvents to avoid damage to finishes and paintwork.
- After using or cleaning a glass table top, wipe it completely dry as leaving the glass unattended when wet may leave water marks that cannot be removed easily.
- For upholstery, vacuum regularly with a soft, non-metallic brush to remove dust and grime and to prevent overall soiling. Follow manufacturer's instructions for spot cleaning.
- If removable, wash upholstery covers periodically. If machine washable, use a cold wash cycle.
- Do not use a dryer. Only air dry the upholstery covers.

ENVIRONMENTAL

- Do not expose the furniture (including outdoor furniture) to direct sunlight. Protect your outdoor furniture with weather-resistant covers, and have curtains and blinds to shield indoor furniture if direct sunlight is unavoidable.
- Bamboo, rattan as well as wood-based furniture are prone to damage and fade with prolonged exposure to extremely high or low humidity conditions. Do not place them in such extreme conditions.
- For outdoor bamboo/rattan furniture, do not place the furniture in shady or moist areas to prevent it from moulding. Bring the furniture indoors during the off season or covered it with weather-resistant covers.

HANDLING

- Do not drag, push or pull furniture when moving them. Lift them up to avoid damage to the furniture legs and scratches on floors.
- Do not sit or stand on the armrests or use the furniture as a stepping stool for safety reasons.
- Do not exceed the recommended weight capacities of the furniture specified.
- Do not use the furniture for any other purpose other than what is intended for.

STORAGE

- Store furniture in a clean, dry environment when not in use.
- If possible, disassemble furniture before storing to save space and prevent damage during transportation.

SPECIFIC CARE

- Engage professional upholstery cleaning services for deeper cleaning if required.
- For genuine leather, suede leather or synthetic leather upholstery, use an appropriate leather conditioner to maintain its suppleness and appearance and prevent drying and cracking. The conditioner also adds a thin protective layer on the leather surface to facilitate easier cleaning.
- If a furniture polish is used for wooden furniture, make sure that it is of low alcohol content.
- To prevent rattan from becoming dry and brittle, spray water on the underside of the furniture piece every six months and wipe down with a dry cloth to remove excess water.
- As an optional protection for bamboo furniture, apply a bamboo sealant/varnish on it for durable protection against scratches, water, UV rays and other weather elements.

CARE AND MAINTENANCE - UPHOLSTERY

CLEANING

- Dust the furniture regularly using a soft cloth or microfibre duster to prevent dust build-up
- Follow the manufacturer's recommendations strictly for cleaning the specific upholstery type.
- Only use cleaning products designed for upholstery and avoid all harsh or abrasive cleaning solvents.
- Vacuum regularly with a soft, non-metallic brush to remove dust and grime and to prevent overall soiling.
- If removable, wash upholstery covers periodically. If machine washable, use a cold wash cycle.
- Do not use a dryer. Only air dry the upholstery covers.
- Engage professional upholstery cleaning services for deeper cleaning if required.

SPILL AND STAINS

- Treat all stains right away. Clean the stains with water, upholstery shampoo or a suitable spot cleaner.
- Do not leave the stains to dry as it will make them harder to clean.
- Wipe up any excess liquid or solids and work from the edge of the stain inwards to avoid spreading.

VELVET / SHERPA / BOUCLE UPHOLSTERY

- Vacuum regularly to prevent the buildup of dirt and dust on the fabric.
- After vacuuming, use a soft-bristle brush to gently brush the fabric to restore the plush appearance.
- Use lukewarm water, mild soap and a non-abrasive cloth to clean. Follow up by drying with a soft cloth, such as a microfibre cloth.
- Only air dry the fabric.
- Do not iron the fabric.
- Position the furniture away from direct sunlight or use curtains and blinds to protect it from excessive exposure.

POLYESTER UPHOLSTERY

- Use a soft-bristle brush to gently agitate the material and manually unbind dirt from the polyester. Then use a hand-held vacuum cleaner to remove the loose dirt and debris.
- Use lukewarm water, mild soap and a non-abrasive cloth to clean. Follow up by drying with a soft cloth, such as a microfibre cloth.
- If the polyester upholstery has a cleaning code label, use the appropriate cleaning solution to clean it. There are four types of cleaning codes on the label:

-
- W** Liquid solvents can be used to clean this fabric.
 - S** Only dry-cleaning solutions can be used on this type of fabric.
 - S/W** Both liquid and dry solvents will work.
 - X** Only specialised cleaning by professionals.
-

- When using a cleaning product, test it on a small hidden part first to check that there are no adverse effects with the polyester fabric.
- Use a disinfecting surface cleaner to deodorize and sanitize the furniture as a final step. Choose a surface cleaner that does not have strong chemicals to effectively and safely disinfect the polyester upholstery. Let it air dry when done.

Well done!

**Love our furniture?
Share it!**

Tag us on instagram or facebook

@KampradsOikos1943

ikiture[®]