

# ASSEMBLY INSTRUCTIONS

Please read the instructions carefully before assembly and keep it for future reference.

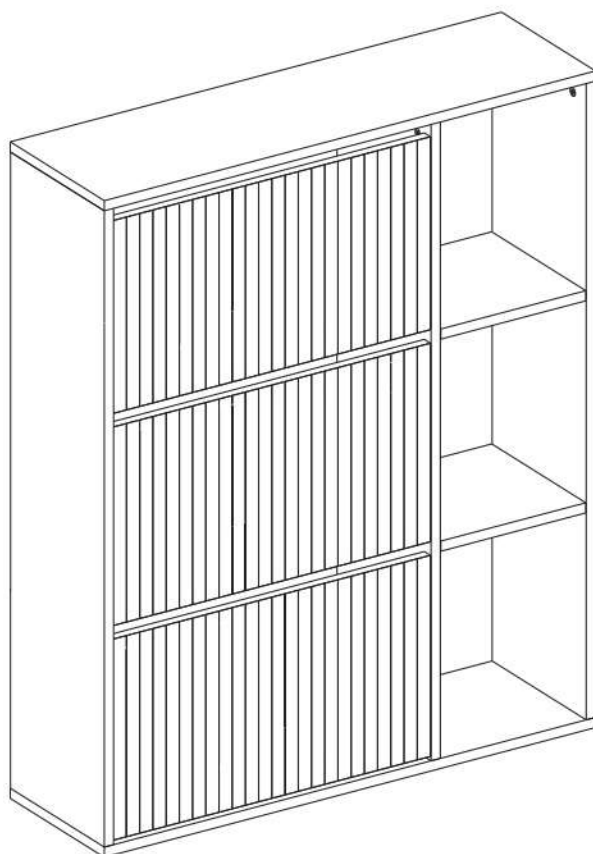
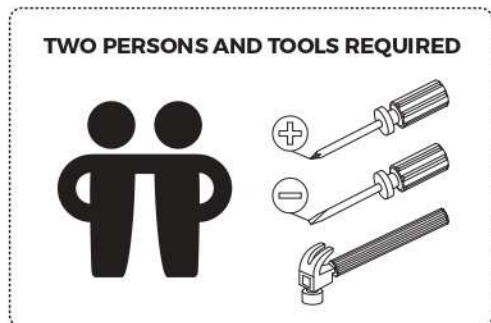

## SHOE STORAGE CABIENT

**Model :** SS-VJ-TICK-3R3S

**Version 1.0**

## Assembly and Maintenance Tips



1. Keep children and pets away from the working area as small parts may cause choking if swallowed.



2. Some furniture may require two persons to assemble for safety reasons.

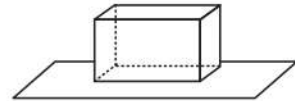

3. To protect the surfaces of the furniture, lay the parts and perform the assembly on top of a soft mat (such as a carpet or cardboard).



4. Keep the furniture away from direct sunlight to avoid fading.



5. Use a soft, damp cloth to clean or wipe surfaces.



6. Never use ammonia-based or abrasive cleaning products to clean as they may damage the finish.



7. Do not place liquids or wet items on furniture as they may leave water marks/stains. Always use a coaster or runner to protect the furniture surface.

# Assembly Checklist



## Read

Read through the instructions carefully before you begin.

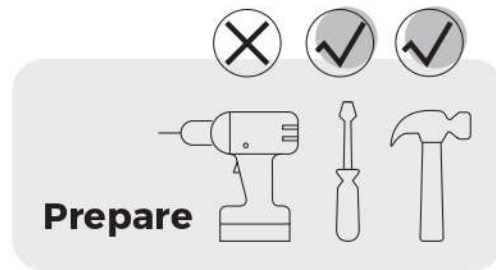

## Prepare

Make sure you have all the required tools. Never use power tools unless instructed.

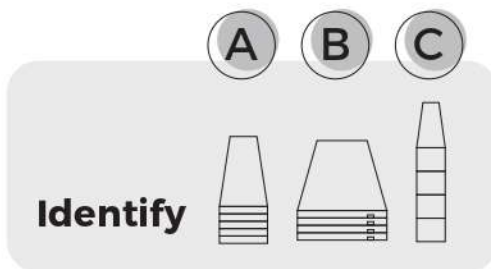

## Identify

Identify and lay out all of the components before you begin assembly.

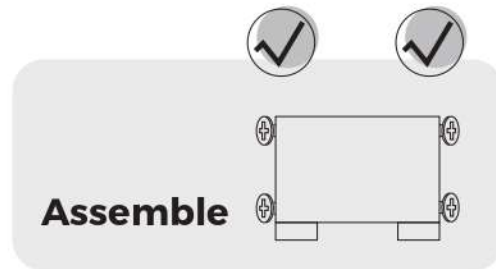

## Assemble





Please fully tighten all screws during the assembly process unless instructed not to do so.

## Helpful Information

- ! Never use power tools unless specifically instructed. They can damage your components or hardware if used incorrectly.
  - ! The most common mistakes made during assembly are using the wrong hardware or getting components back to front.
  - ! When assembling the product, it is recommended to do so on top of a soft surface such as a carpet or cardboard to avoid scratches and damages to the furniture surfaces.
  - ! Bulky items such as wardrobes should be assembled in the location when the assembled piece will be used to avoid moving them through doors or tight passages.
  - ! Never use any glue until you are certain that the parts belong together.
  - ! Periodically check that all connections are secured and follow all care and maintenance instructions stated.
  - ! If you encounter any assembly difficulties or missing components and/or hardware, please contact our Customer Service for further assistance.
-

# Hardware List

Please ensure that all parts and hardware are in the packaging contents. If there are any missing parts and/or hardware, please contact our Customer Service as soon as possible.

<p><b>Part A</b> 6pcs Φ6x30mm</p> 	<p><b>Part B</b> 6pcs Φ14.8x9.5mm</p> 	<p><b>Part C</b> 20pcs M6x30mm</p> 	<p><b>Part D</b> 23 pcs M4x35mm</p> 
<p><b>Part E</b> 36pcs M3.5x14mm</p> 	<p><b>Part F</b> 1pc M4x12mm</p> 	<p><b>Part G</b> 1pc 66mmx15mmx1mm</p> 	<p><b>Part H</b> 6pcs 26mmx17mmx7mm</p> 
<p><b>Part K</b> 6pcs M4x10mm</p> 	<p><b>Part N</b> 1pc</p> 	<p><b>Part O</b> 6pcs 24mmx17mmx11mm</p> 	<p><b>Part P</b> 6pcs 18mmx11mmx19mm</p> 
<p><b>Part R</b> 3pcs 255mmx195mm</p> 	<p><b>Part L</b> 3pcs 255mmx195mm</p> 		

# Parts List



Wipe only with a dry cloth

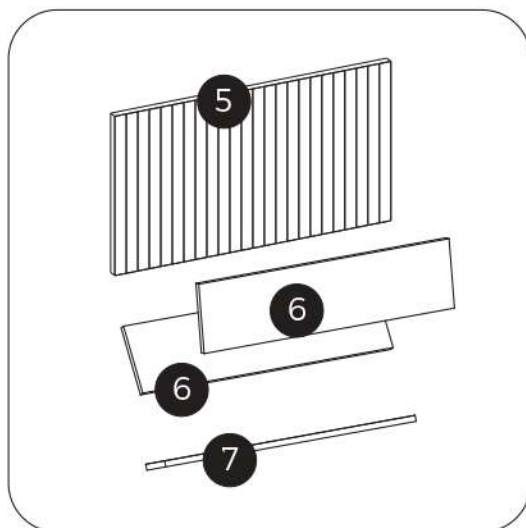
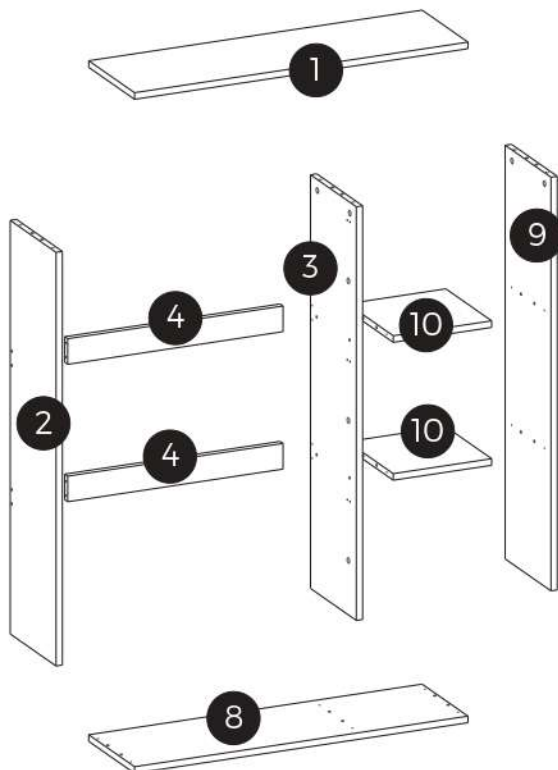

**x3**

# STEP 1

## Part H

6pcs

26mmx17mmx7mm



## Part O

6pcs

24mmx17mmx11mm

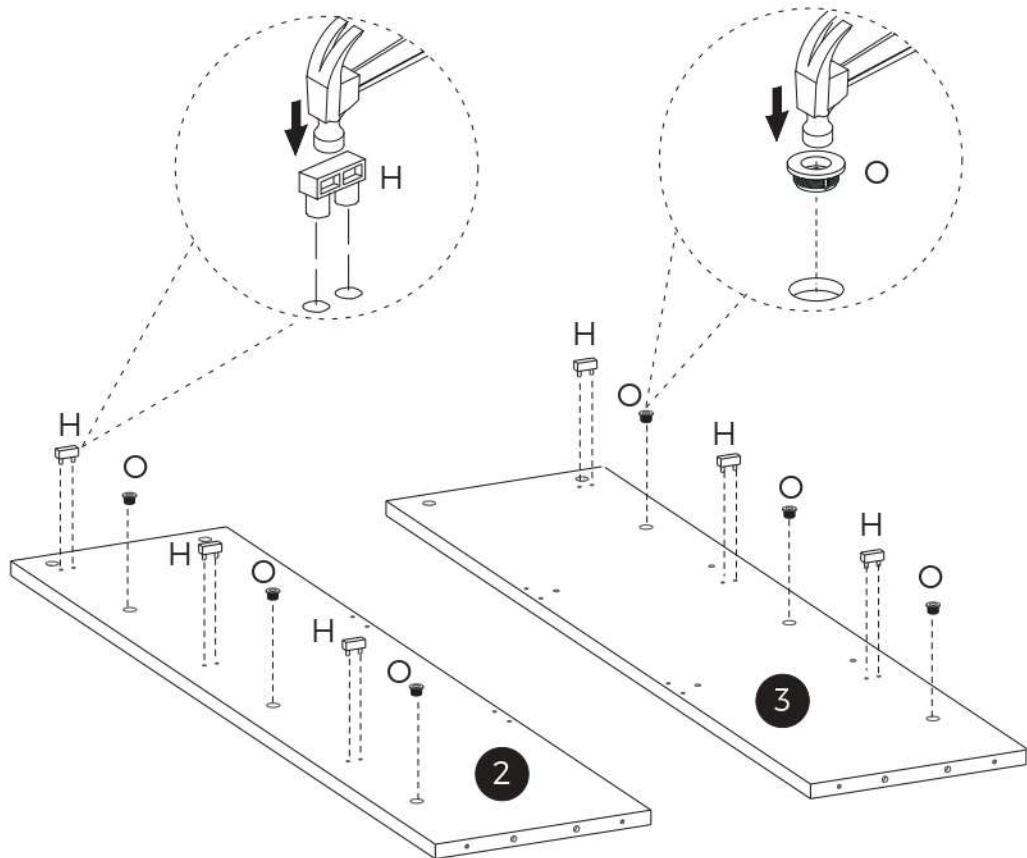

# STEP 2

## Part D

8pcs

M4x35mm

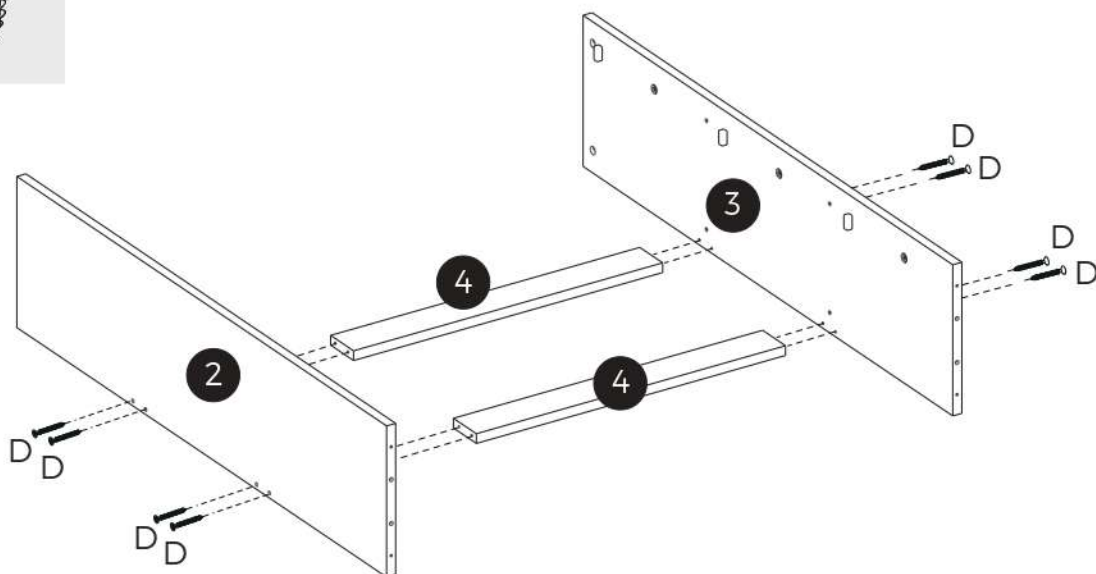

## STEP 3

### Part D

8pcs  
M4x35mm



### Part C

8pcs  
Ø6x30mm

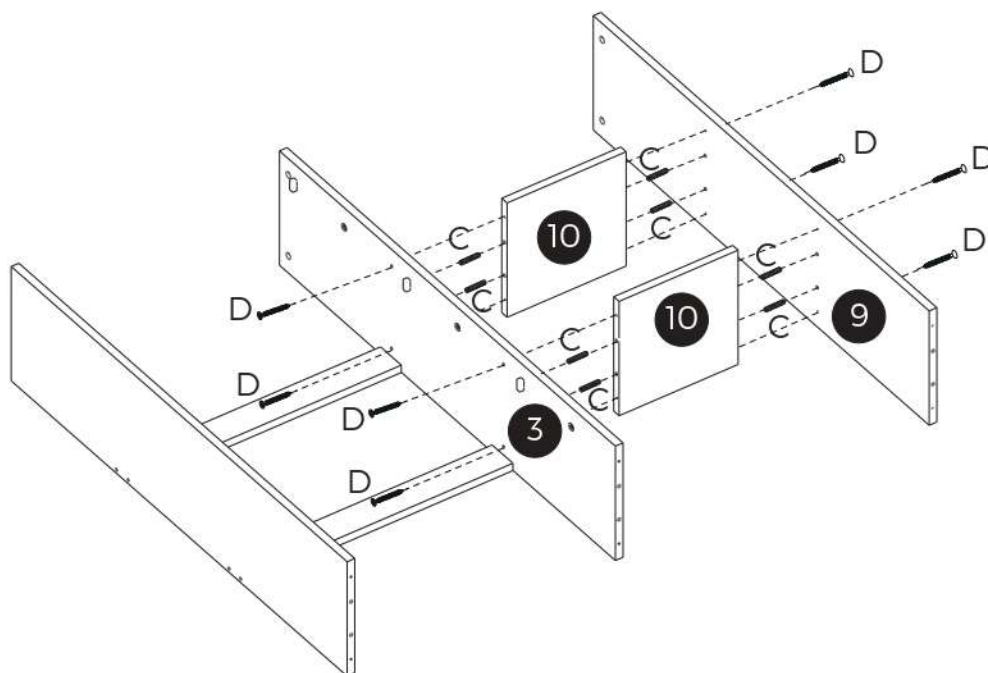

## STEP 4

### Part A

6pcs  
Ø6x30mm



### Part F

1pc  
M4x12mm



### Part G

1pc  
66mmx15mmx1mm



### OPTIONAL

Install Part G only if you wish to secure the product to a wall. See Step 12.

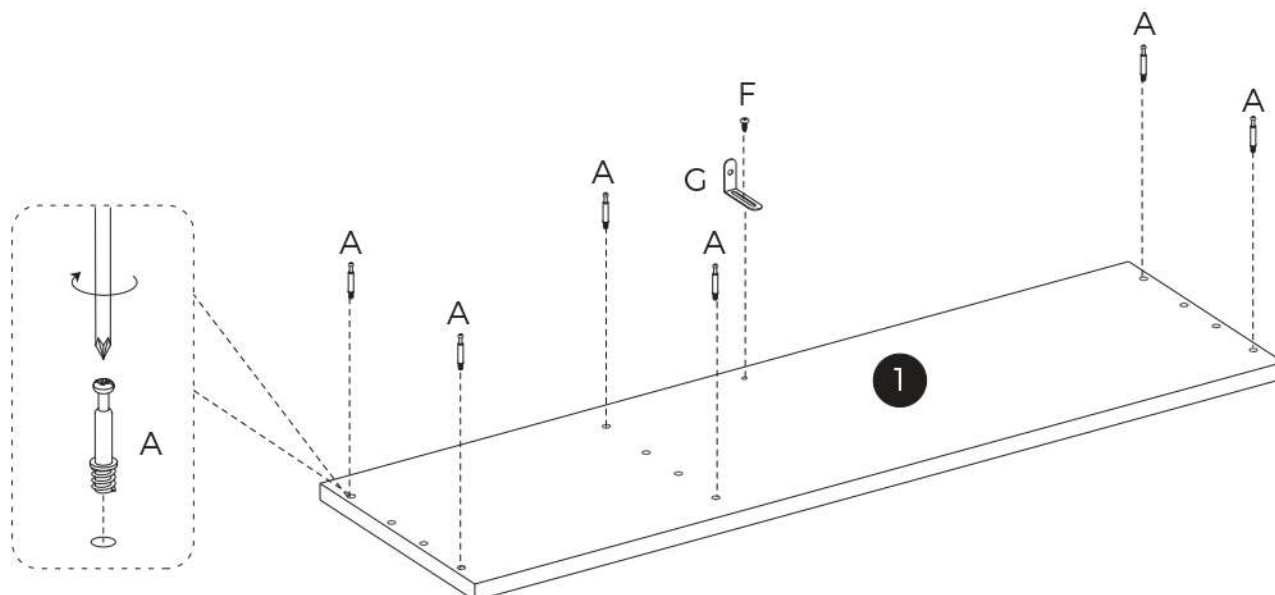

# STEP 5

## Part B

6pcs

Ø14.8x9.5mm

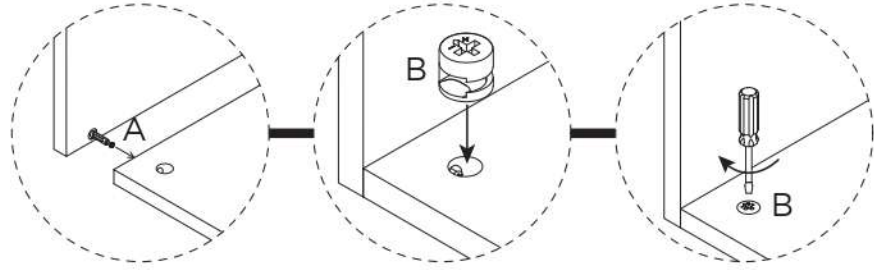

## Part C

6pcs

M6x30mm

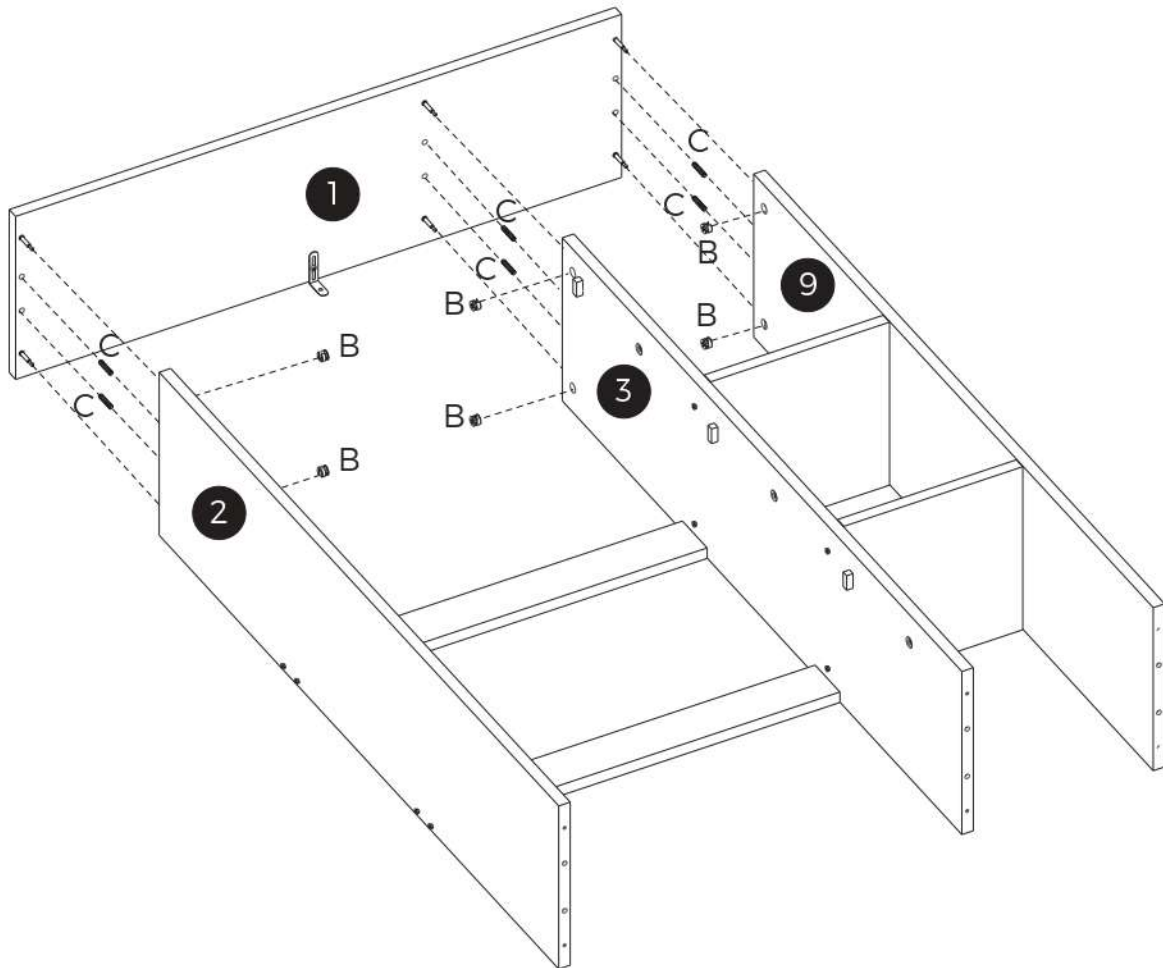

# STEP 6

## Part D

6pcs  
M4x35mm



-----

## Part C

6pcs  
Ø6x30mm

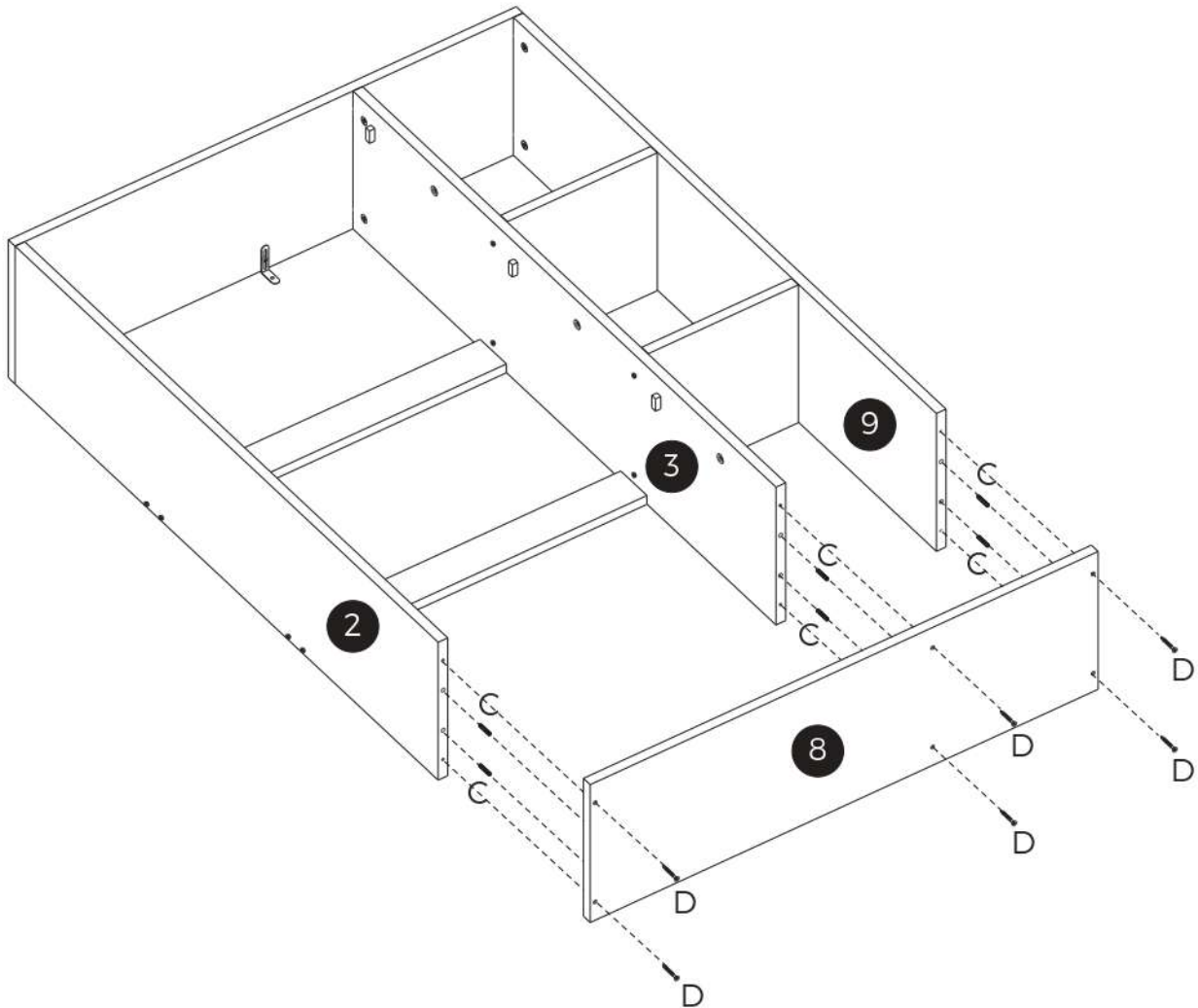

## STEP 7

### Part E

18pcs  
M3.5x14mm



### Part L

3pcs  
255mmx195mm



### Part R

3pcs  
255mmx195mm

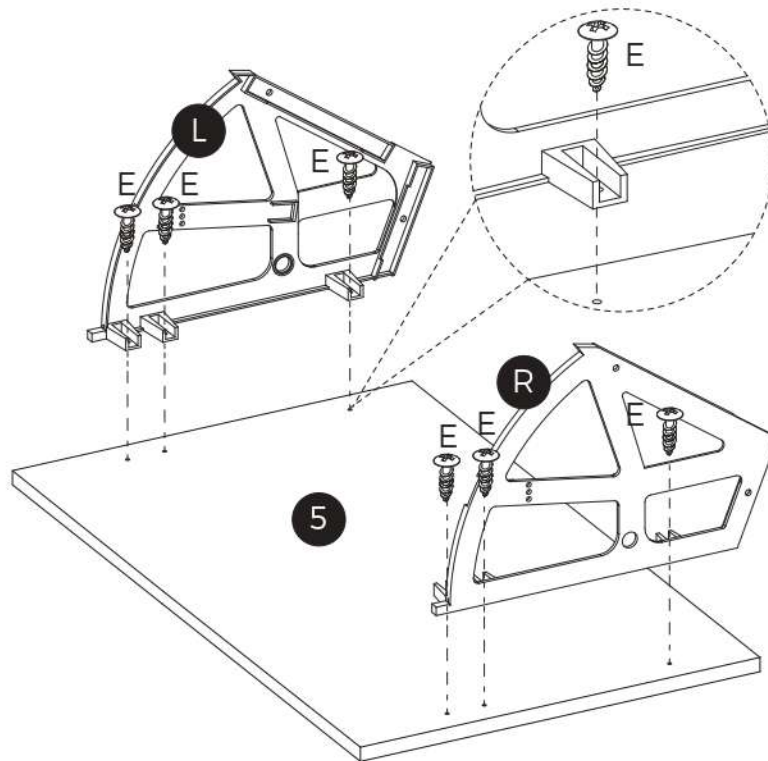

**x3**

Assemble 3 sets

## STEP 8

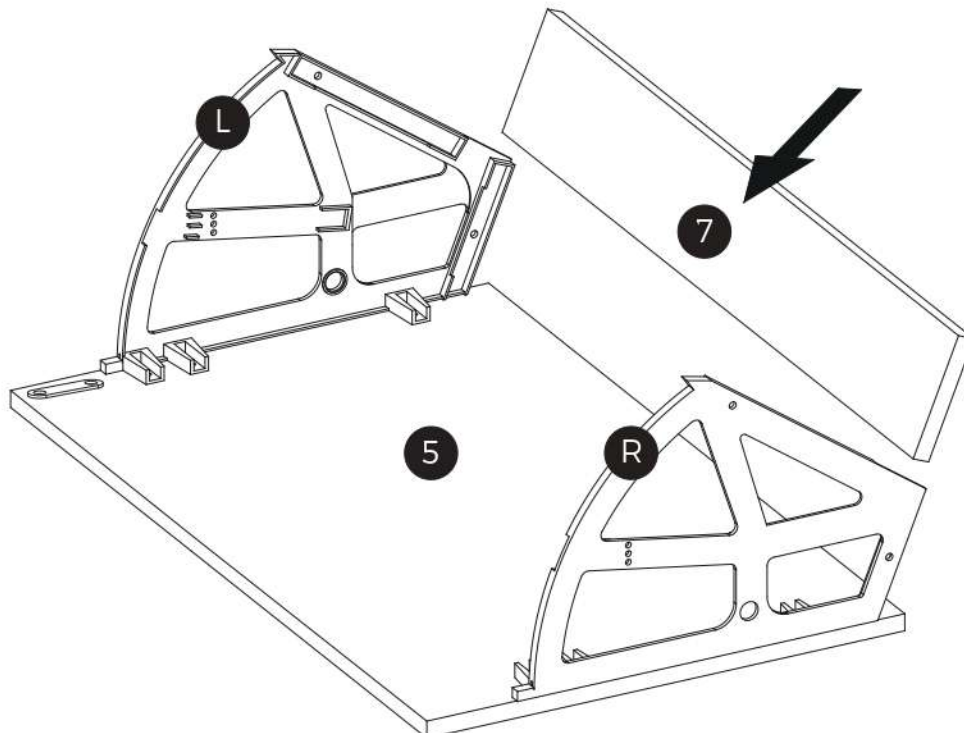

**x3**

Assemble 3 sets

## STEP 9

### Part E

6pcs  
M3.5x14mm

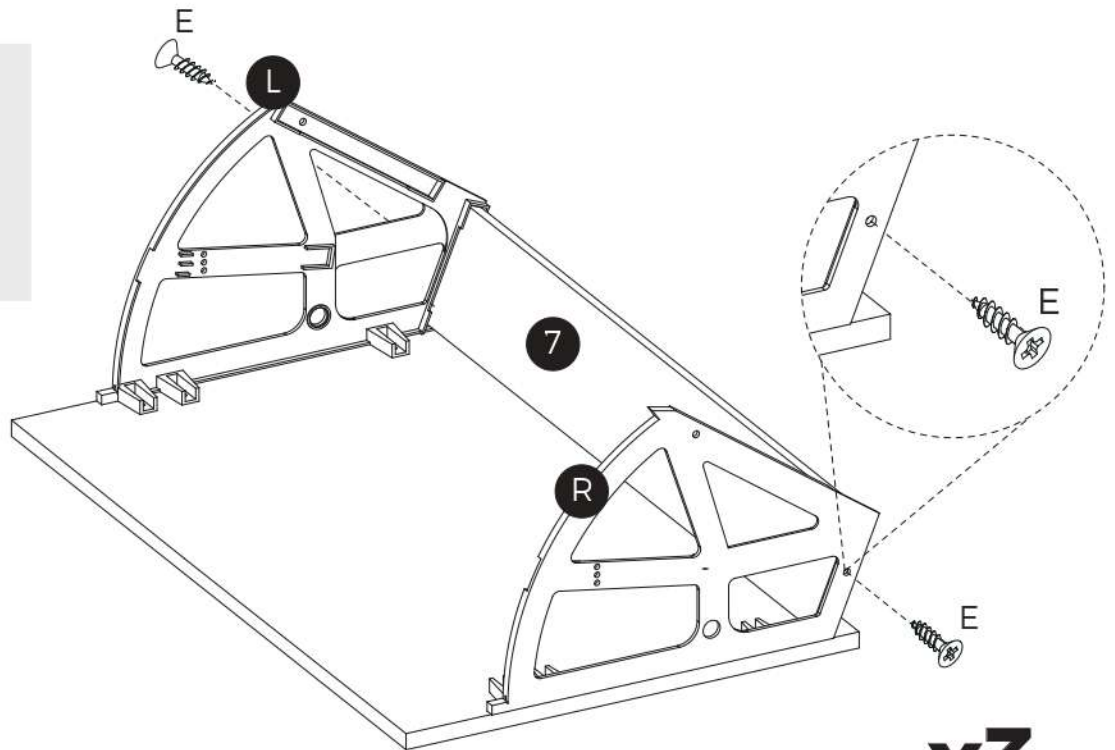

**x3**

Assemble 3 sets

## STEP 10

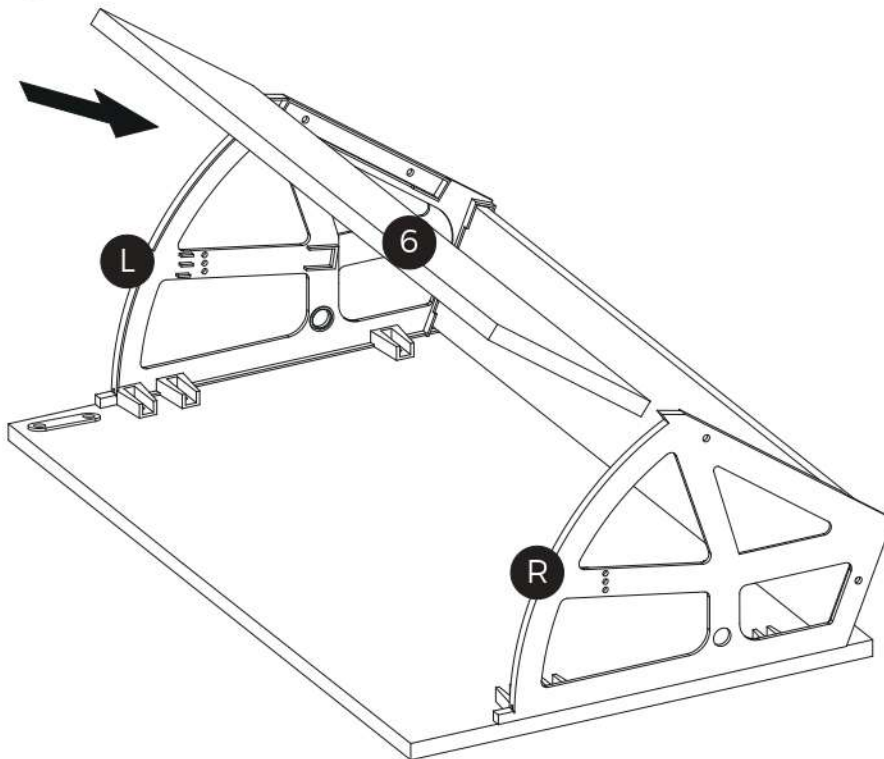

**x3**

Assemble 3 sets

# STEP 11

## Part E

6pcs

M3.5x14mm

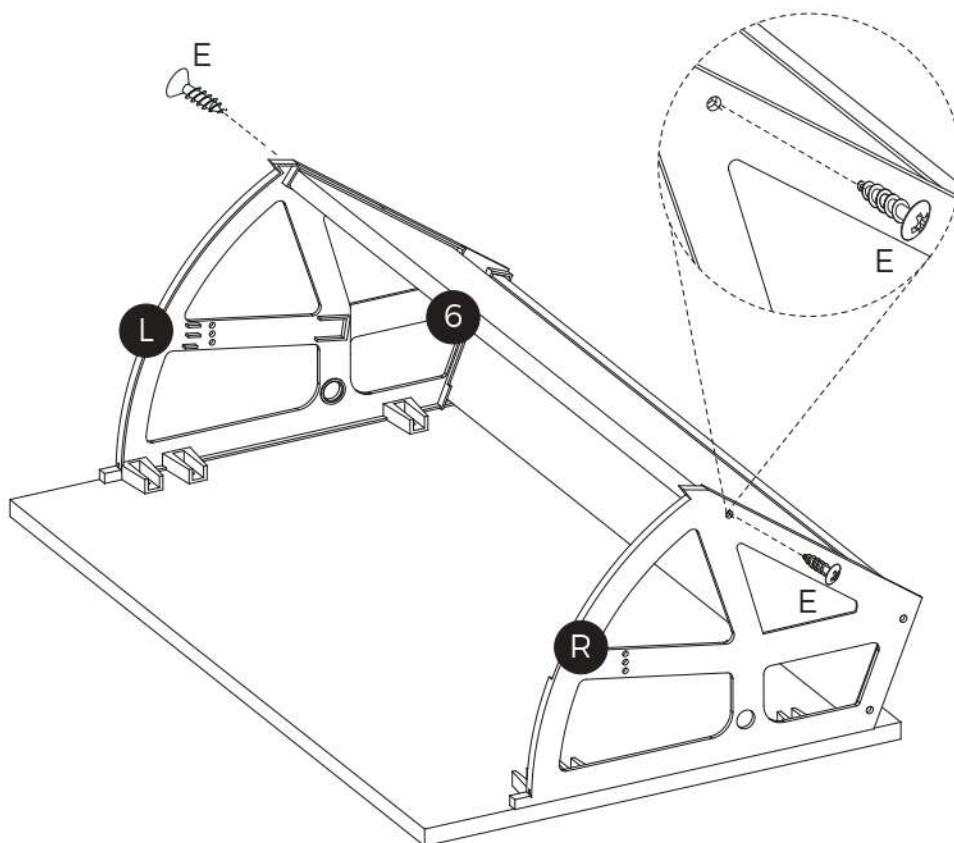

**x3**

Assemble 3 sets

# STEP 12

## Part D

1pc  
M4x35mm



## Part N

1pc



## OPTIONAL

Do this step only if you wish to secure the product to a wall. It is highly recommended that you do so for safety reasons.

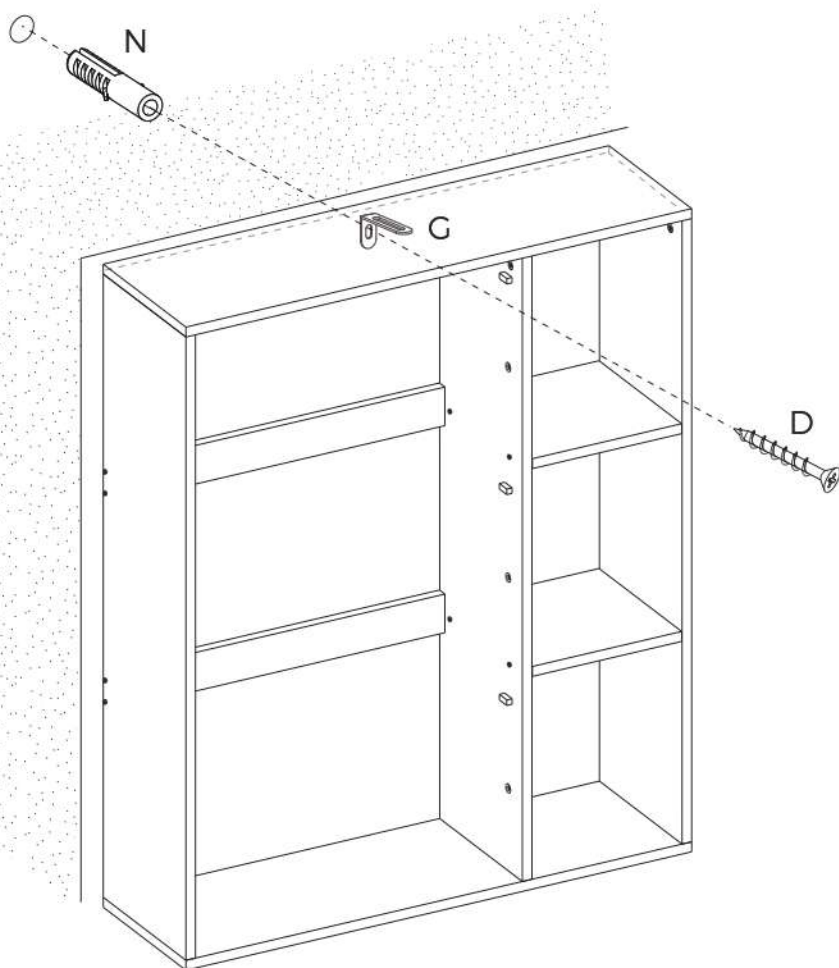

Pre-drill hole in the wall

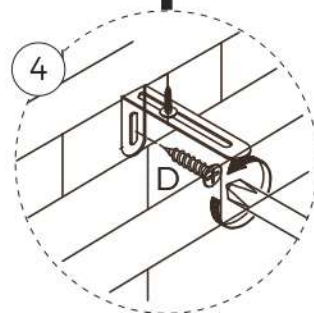
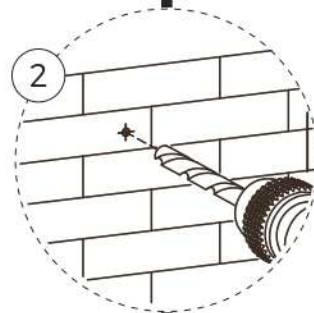
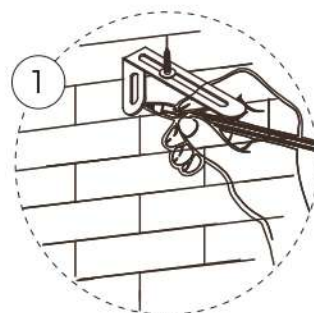

# STEP 13

## Part P

6pcs

18mmx11mmx19mm



## Part K

6pcs

M4x10mm

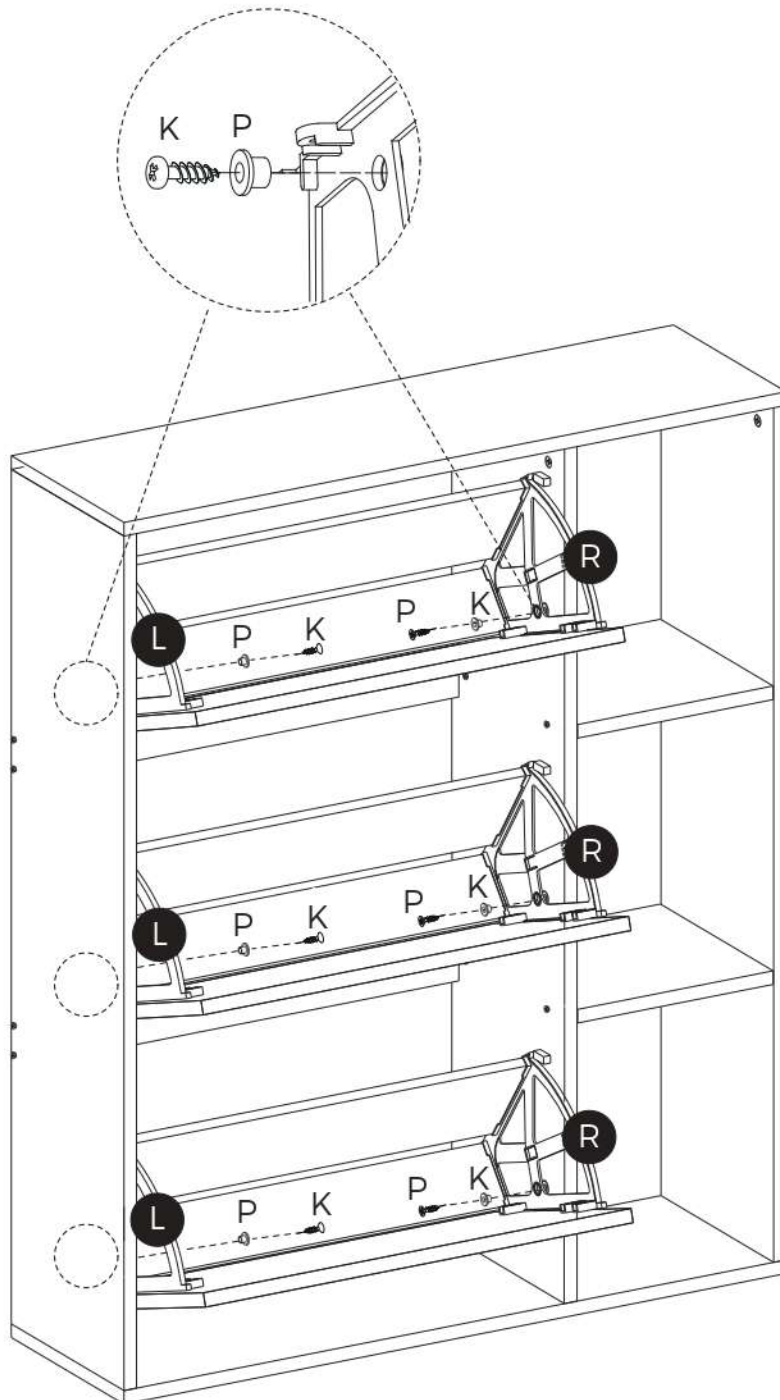

# STEP 14

## Part E

6 pcs

M3.5x14mm

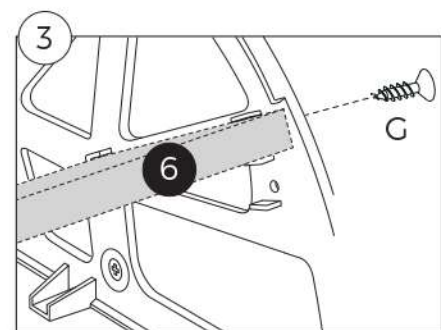
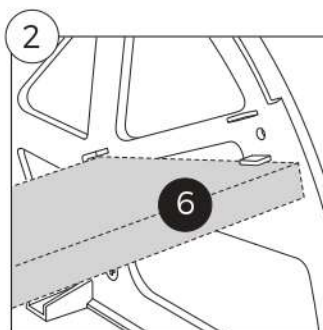
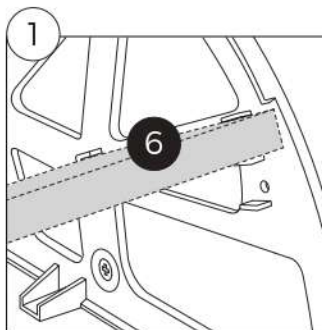
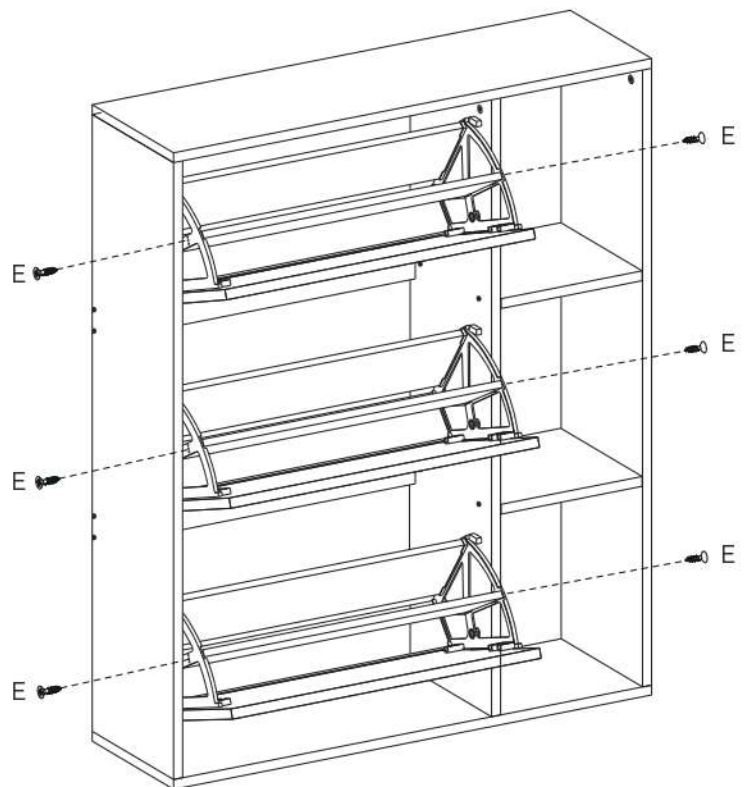
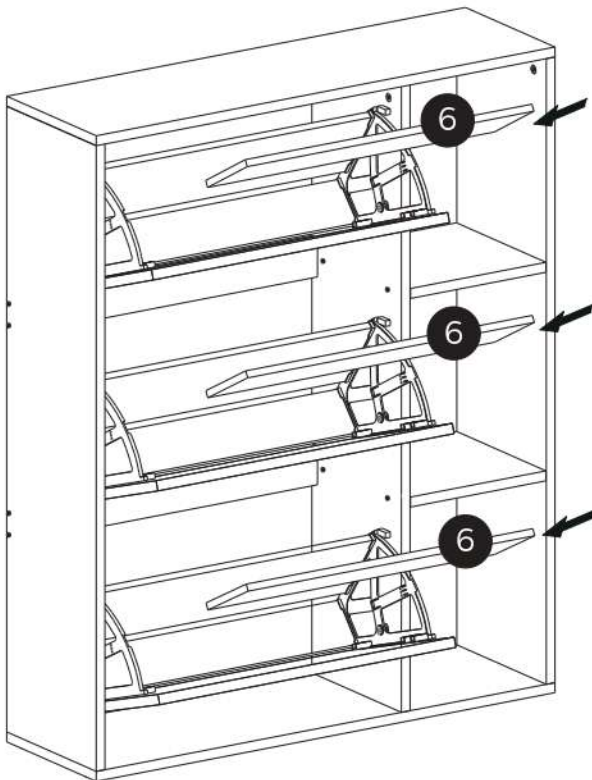

# CARE AND MAINTENANCE

## GENERAL

- Periodically check all screws, bolts and joints connections and tighten them if necessary.
- Periodically check for any damage and deteriorated parts and components and seek repairs or replacements if needed.
- Do not allow any liquids to remain on the furniture as this may cause stains and allow the liquid to be absorbed into the finishes and materials. In some cases, this may also cause warping and/or cracking of the materials and finishes. Use coasters and placemats for all food and beverages.
- Do not place hot items, such as dishes, pots and cups, directly on the furniture. Use coasters and placemats for all food and beverages.
- Keep sharp and pointed objects away from furniture to avoid damaging the surface and finish.
- Do not place the furniture near hot objects, heating vents or heating equipment.
- Do not place the furniture in moist areas, such as bathrooms, to avoid water damage.

## CLEANING AND CARE

- Dust the furniture regularly using a soft cloth or microfibre duster to prevent dust build-up
- Only wipe and clean with a soft, damp cloth with a mild cleaning detergent.
- Do not use abrasive cleaning materials such as scouring pads and chemical cleaning solvents to avoid damage to finishes and paintwork.
- After using or cleaning a glass table top, wipe it completely dry as leaving the glass unattended when wet may leave water marks that cannot be removed easily.
- For upholstery, vacuum regularly with a soft, non-metallic brush to remove dust and grime and to prevent overall soiling. Follow manufacturer's instructions for spot cleaning.
- If removable, wash upholstery covers periodically. If machine washable, use a cold wash cycle.
- Do not use a dryer. Only air dry the upholstery covers.

## ENVIRONMENTAL

- Do not expose the furniture (including outdoor furniture) to direct sunlight. Protect your outdoor furniture with weather-resistant covers, and have curtains and blinds to shield indoor furniture if direct sunlight is unavoidable.
- Bamboo, rattan as well as wood-based furniture are prone to damage and fade with prolonged exposure to extremely high or low humidity conditions. Do not place them in such extreme conditions.
- For outdoor bamboo/rattan furniture, do not place the furniture in shady or moist areas to prevent it from moulding. Bring the furniture indoors during the off season or covered it with weather-resistant covers.

## HANDLING

- Do not drag, push or pull furniture when moving them. Lift them up to avoid damage to the furniture legs and scratches on floors.
- Do not sit or stand on the armrests or use the furniture as a stepping stool for safety reasons.
- Do not exceed the recommended weight capacities of the furniture specified.
- Do not use the furniture for any other purpose other than what is intended for.

## STORAGE

- Store furniture in a clean, dry environment when not in use.
- If possible, disassemble furniture before storing to save space and prevent damage during transportation.