

# ASSEMBLY INSTRUCTIONS

Please read the instructions carefully before assembly and keep it for future reference.

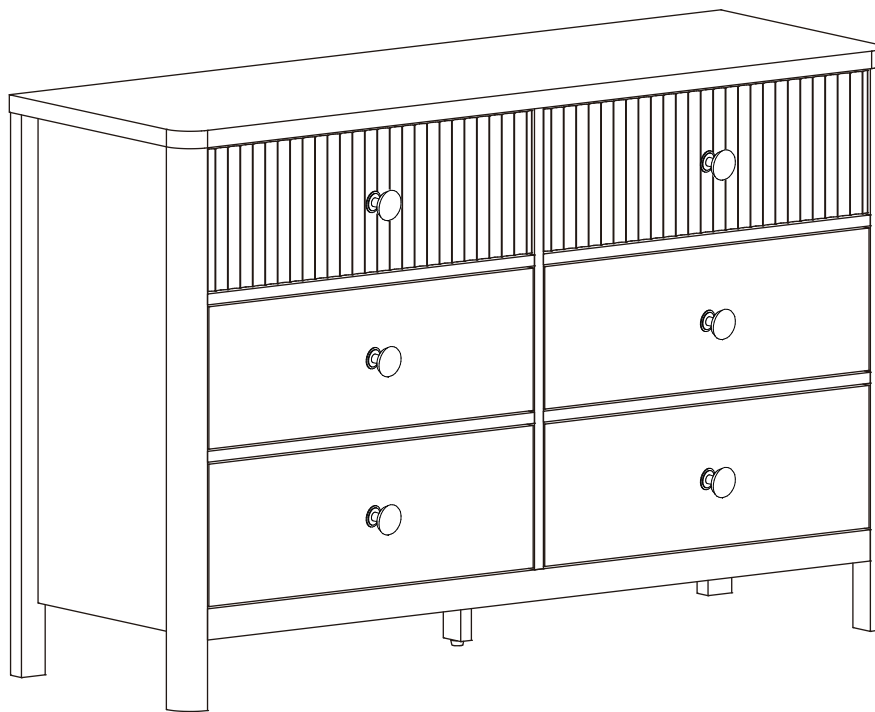
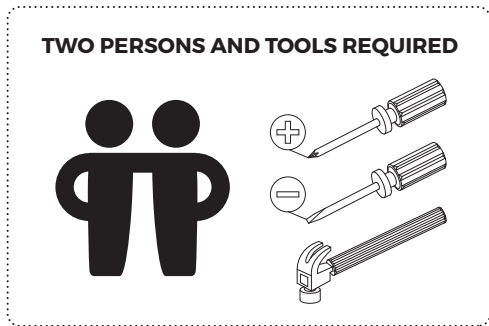

## CHEST OF DRAWERS

**Model** : COD-WEST-6D

**Version** 1.0

## Assembly and Maintenance Tips



1. Keep children and pets away from the working area as small parts may cause choking if swallowed.



2. Some furniture may require two persons to assemble for safety reasons.

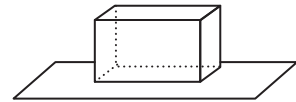

3. To protect the surfaces of the furniture, lay the parts and perform the assembly on top of a soft mat (such as a carpet or cardboard).

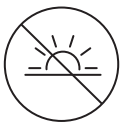

4. Keep the furniture away from direct sunlight to avoid fading.



5. Use a soft, damp cloth to clean or wipe surfaces.



6. Never use ammonia-based or abrasive cleaning products to clean as they may damage the finish.



7. Do not place liquids or wet items on furniture as they may leave water marks/stains. Always use a coaster or runner to protect the furniture surface.

# Assembly Checklist



## Read

Read through the instructions carefully before you begin.

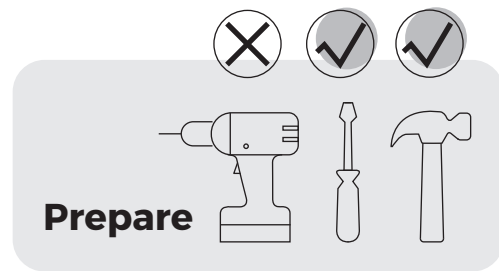

## Prepare

Make sure you have all the required tools. Never use power tools unless instructed.

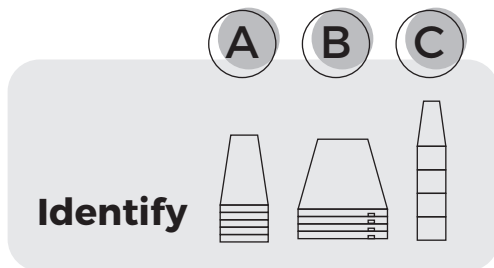

## Identify

Identify and lay out all of the components before you begin assembly.

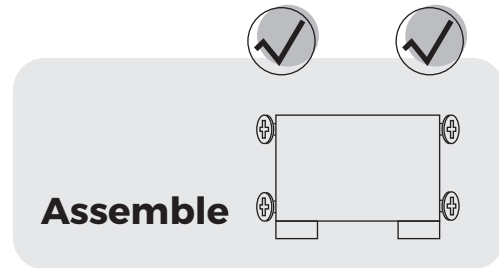

## Assemble











Please fully tighten all screws during the assembly process unless instructed not to do so.

## Helpful Information

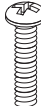
- ! Never use power tools unless specifically instructed. They can damage your components or hardware if used incorrectly.
- ! The most common mistakes made during assembly are using the wrong hardware or getting components back to front.
- ! When assembling the product, it is recommended to do so on top of a soft surface such as a carpet or cardboard to avoid scratches and damages to the furniture surfaces.
- ! Bulky items such as wardrobes should be assembled in the location when the assembled piece will be used to avoid moving them through doors or tight passages.
- ! Never use any glue until you are certain that the parts belong together.
- ! Periodically check that all connections are secured and follow all care and maintenance instructions stated.
- ! If you encounter any assembly difficulties or missing components and/or hardware, please contact our Customer Service for further assistance.

# Hardware List

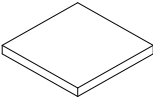
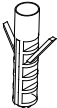
Please ensure that all parts and hardware are in the packaging contents. If there are any missing parts and/or hardware, please contact our Customer Service as soon as possible.

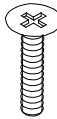
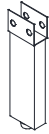

<p><b>Part A</b> 70pcs 6x35mm</p> 	<p><b>Part B</b> 70pcs 15x9.2mm</p> 	<p><b>Part C</b> 8pcs Ø6x30mm</p> 	<p><b>Part D</b> 12pcs LENGTH: 30CM</p> 
<p><b>Part E</b> 12pcs LENGTH: 30CM</p> 	<p><b>Part F</b> 6pcs</p> 	<p><b>Part G</b> 6pcs 4x18mm</p> 	<p><b>Part H</b> 72pcs 3x12mm</p> 
<p><b>Part I</b> 38pcs 4x35mm</p> 	<p><b>Part J</b> 2pcs</p> 	<p><b>Part K</b> 6pcs</p> 	<p><b>Part L</b> 2pcs 4x12mm</p> 
<p><b>Part M</b> 4pcs</p> 	<p><b>Part N</b> 2pcs</p> 	<p><b>Part O</b> 8 sets 3x16mm</p> 	<p><b>Part P</b> 2pcs</p> 
<p><b>Part Q</b> 2pcs 4x10mm</p> 	<p><b>Part R</b> 1pc</p> 		

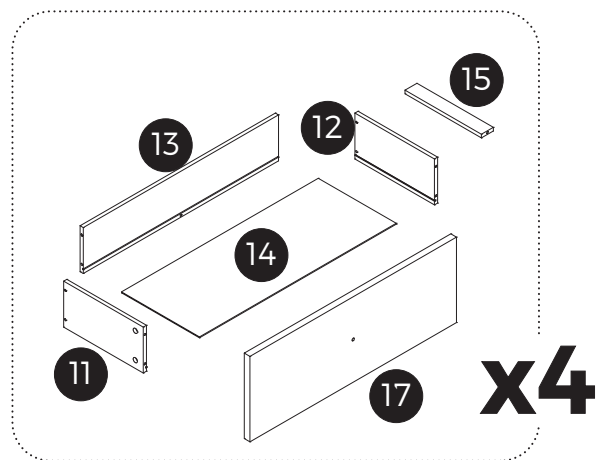
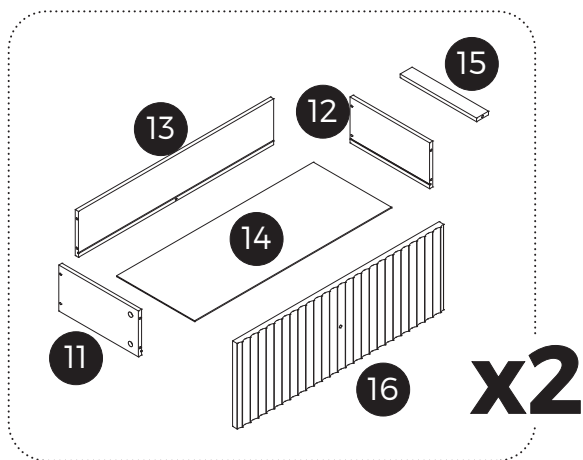
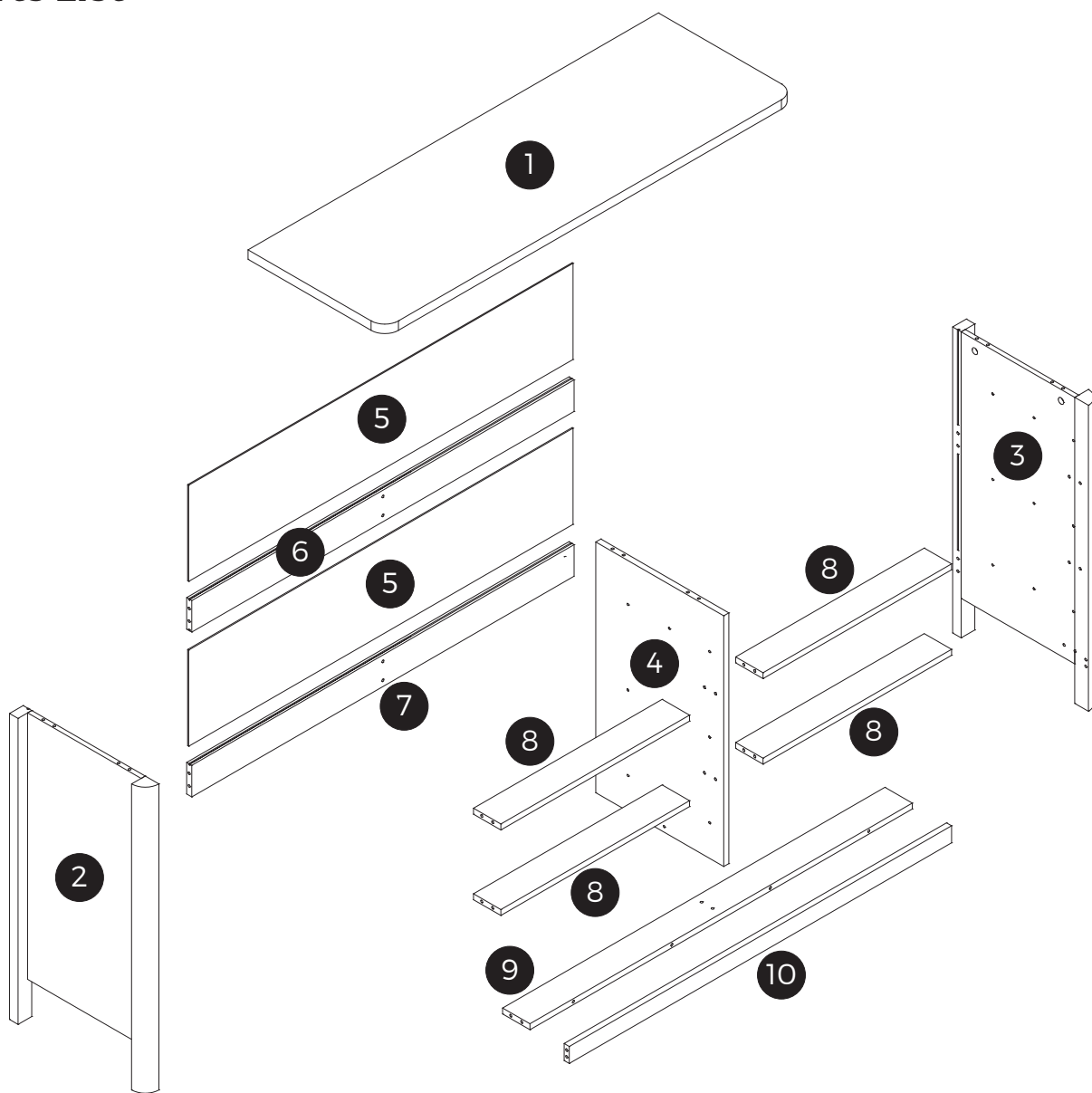
# Parts List

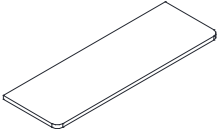

# Parts List

Please ensure that all parts and hardware are in the packaging contents. If there are any missing parts and/or hardware, please contact our Customer Service as soon as possible.

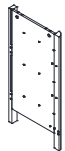
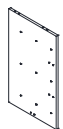
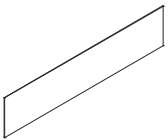
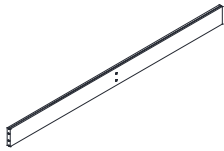
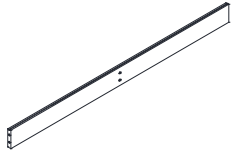
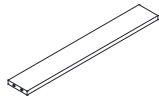
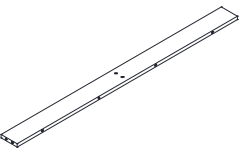
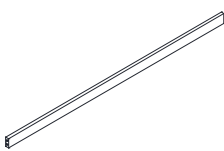
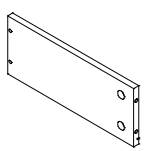
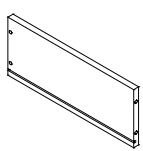
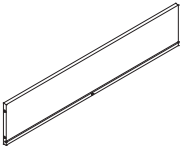
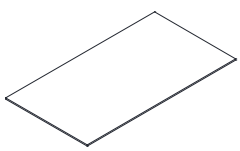
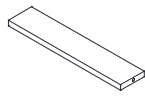
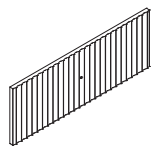
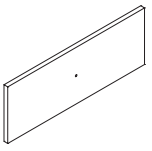
<b>Part 1</b> 1pc 	<b>Part 2</b> 1pc 	<b>Part 3</b> 1pc 	<b>Part 4</b> 1pc 
<b>Part 5</b> 2pcs 	<b>Part 6</b> 1pc 	<b>Part 7</b> 1pc 	<b>Part 8</b> 4pcs 
<b>Part 9</b> 1pc 	<b>Part 10</b> 1pc 	<b>Part 11</b> 6pcs 	<b>Part 12</b> 6pcs 
<b>Part 13</b> 6pcs 	<b>Part 14</b> 6pcs 	<b>Part 15</b> 6pcs 	<b>Part 16</b> 2pcs 
<b>Part 17</b> 4pcs 			

# STEP 1

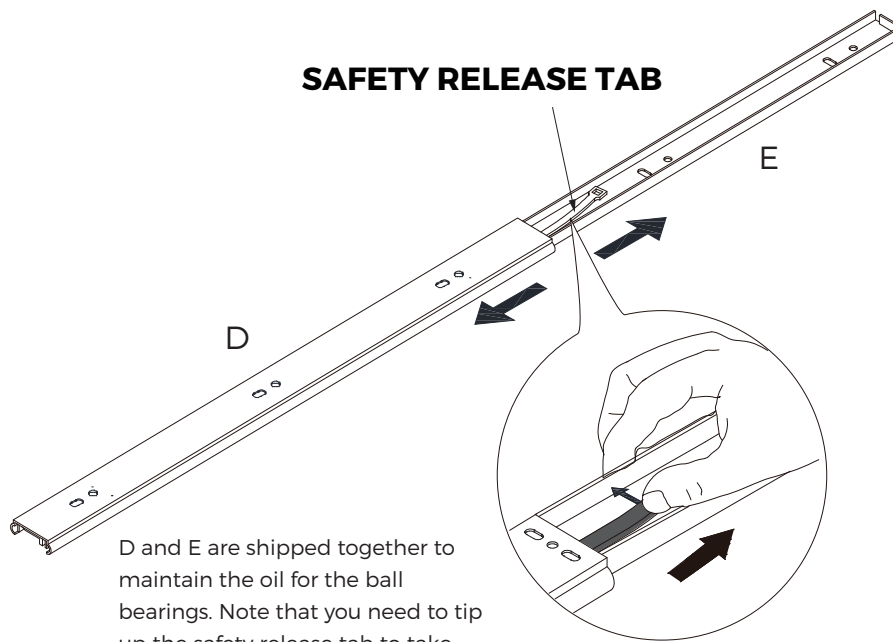

D and E are shipped together to maintain the oil for the ball bearings. Note that you need to tip up the safety release tab to take out Part E prior to assembly.

# STEP 2

**Part D**  
6pcs



**Part H**  
18pcs  
3x12mm

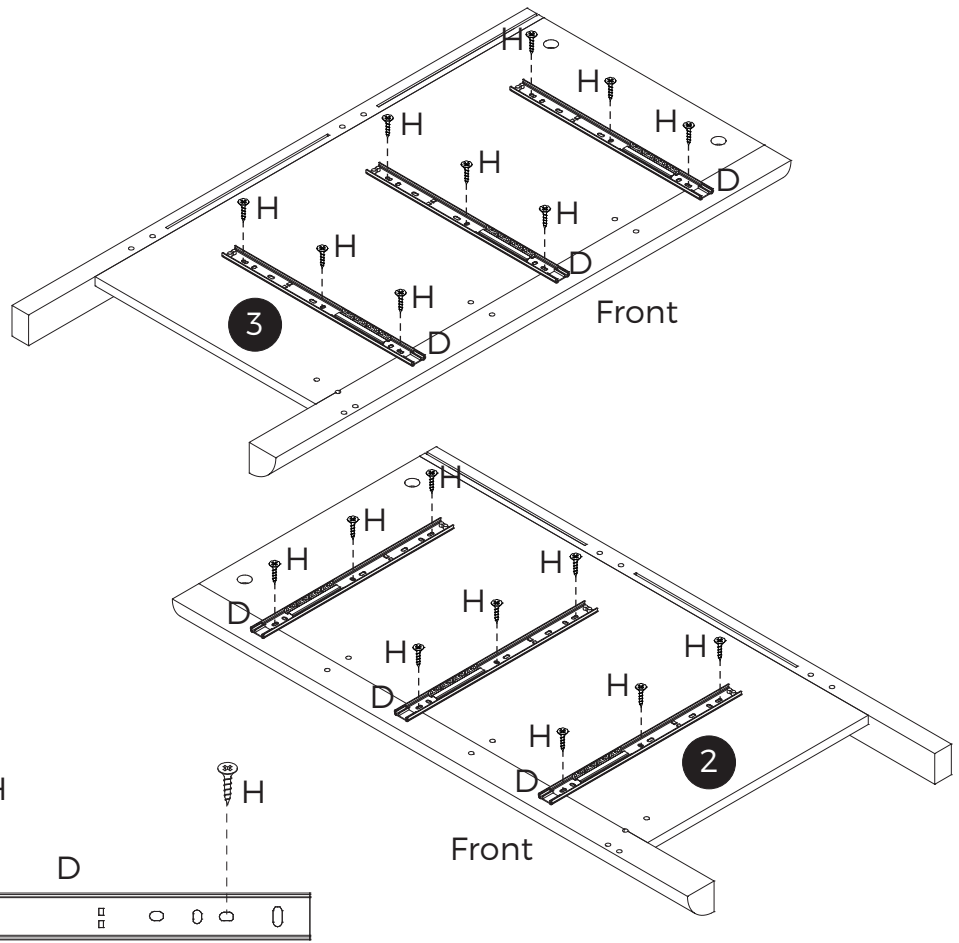

Front

# STEP 3

## Part A

22pcs

6x35mm

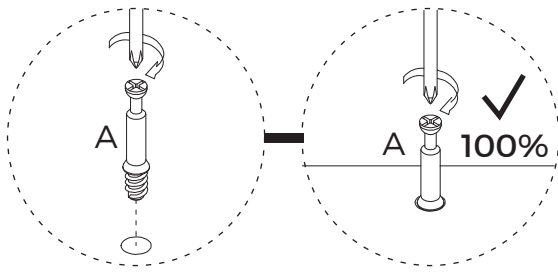
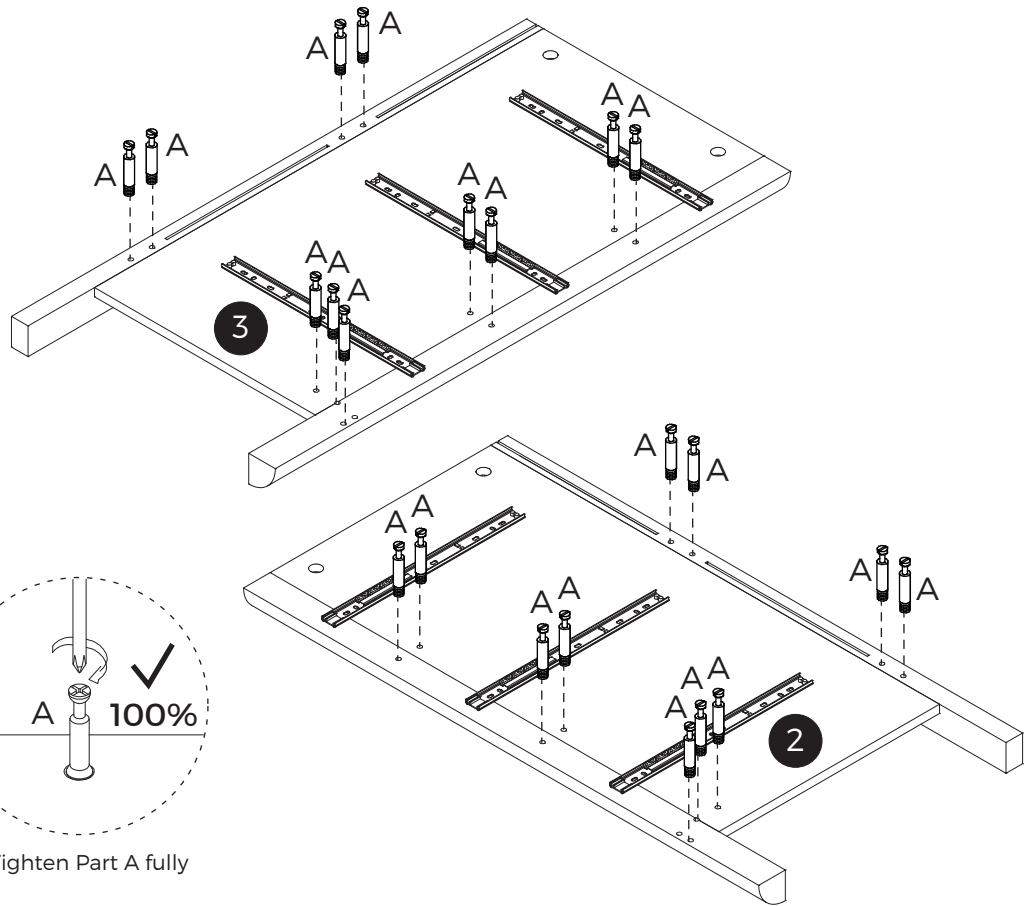
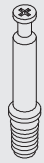

Tighten Part A fully

# STEP 4

## Part D

6pcs



## Part H

18pcs

3x12mm

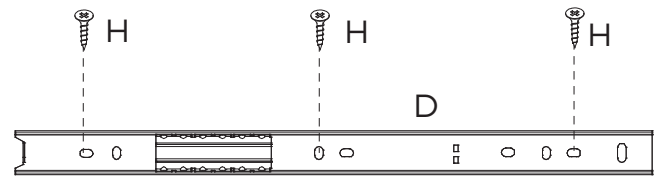

Front

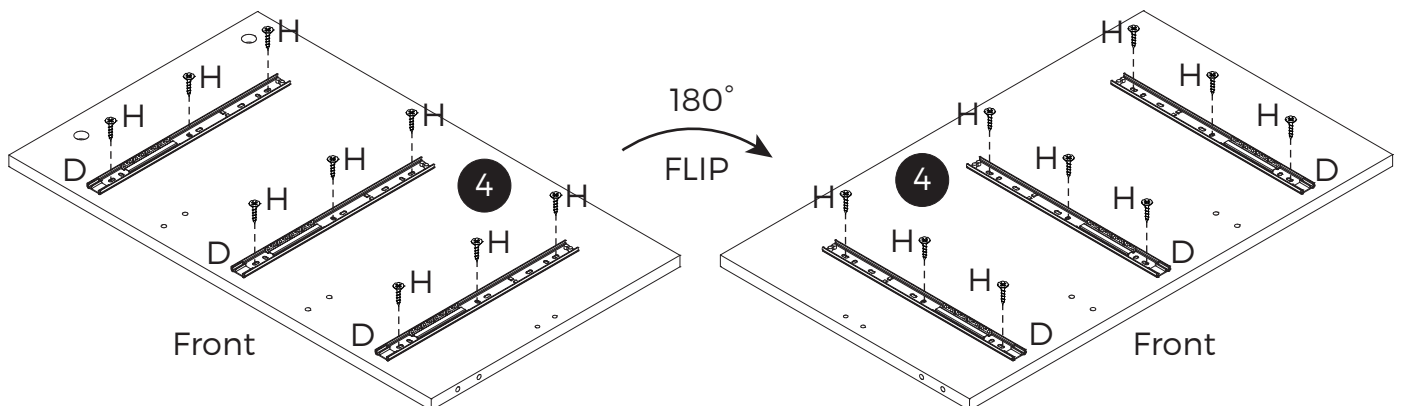

## STEP 5

### Part A

8pcs

6x35mm

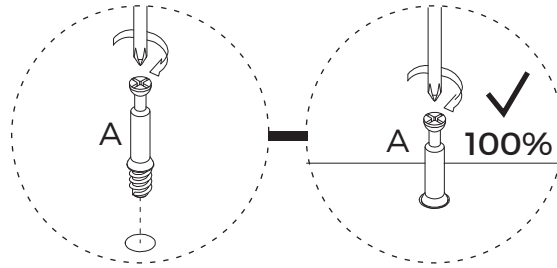
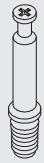

Tighten Part A fully

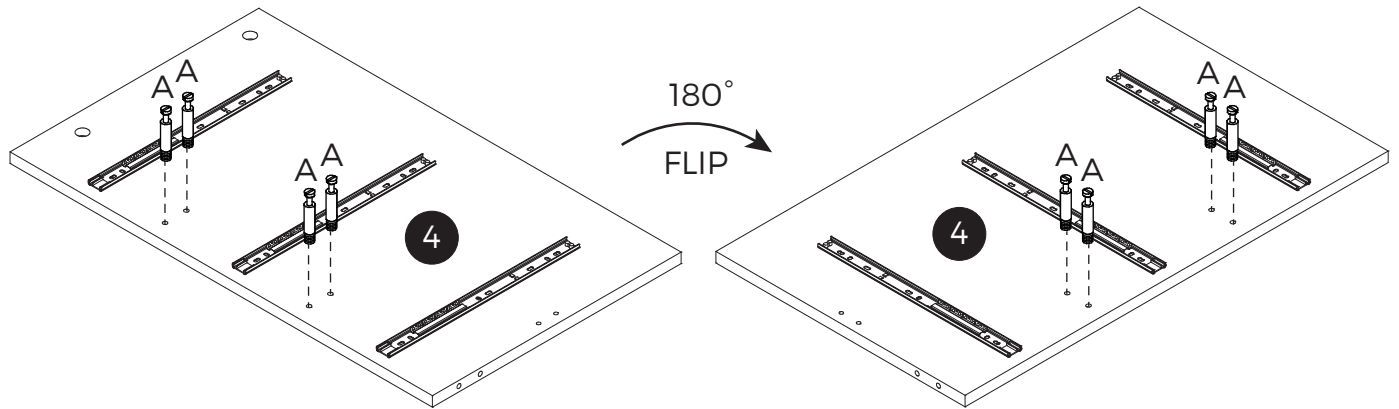

## STEP 6

### Part B

8pcs

15x9.2mm

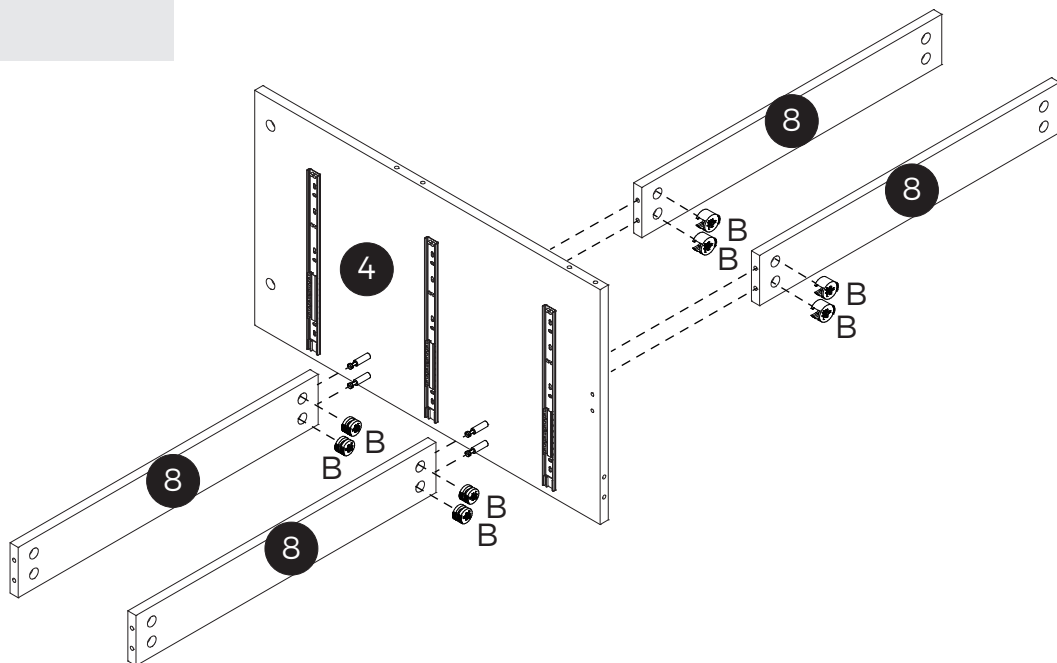
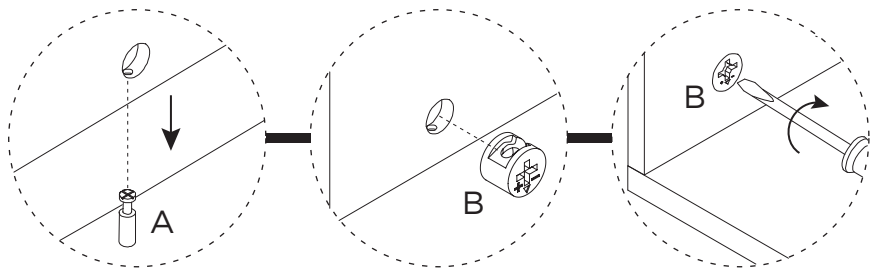

## STEP 7

### Part A

4pcs  
6x35mm

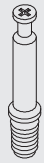

### Part B

4pcs  
15x9.2mm

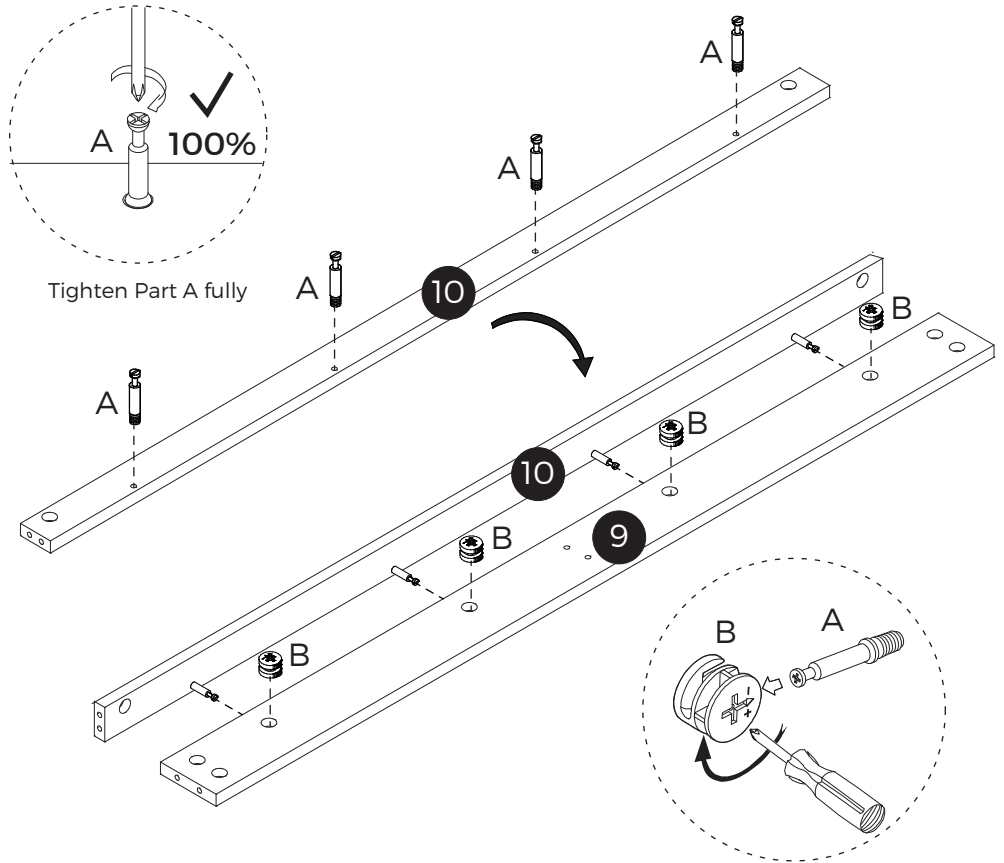

## STEP 8

### Part I

2pcs  
4x35mm

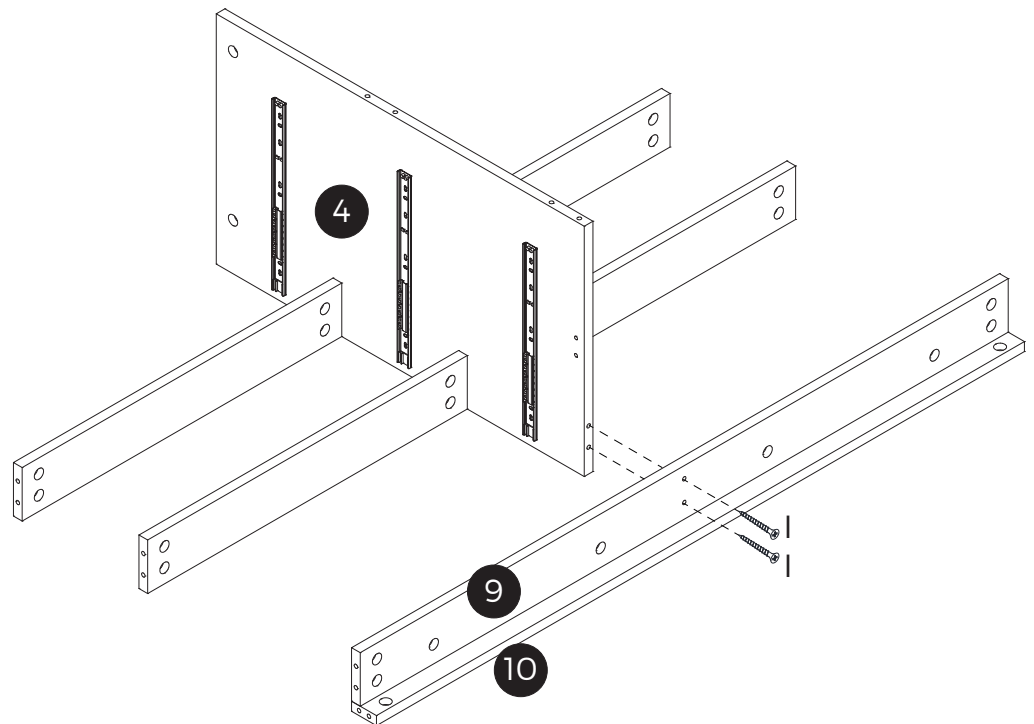

## STEP 9

### Part I

4pcs  
4x35mm

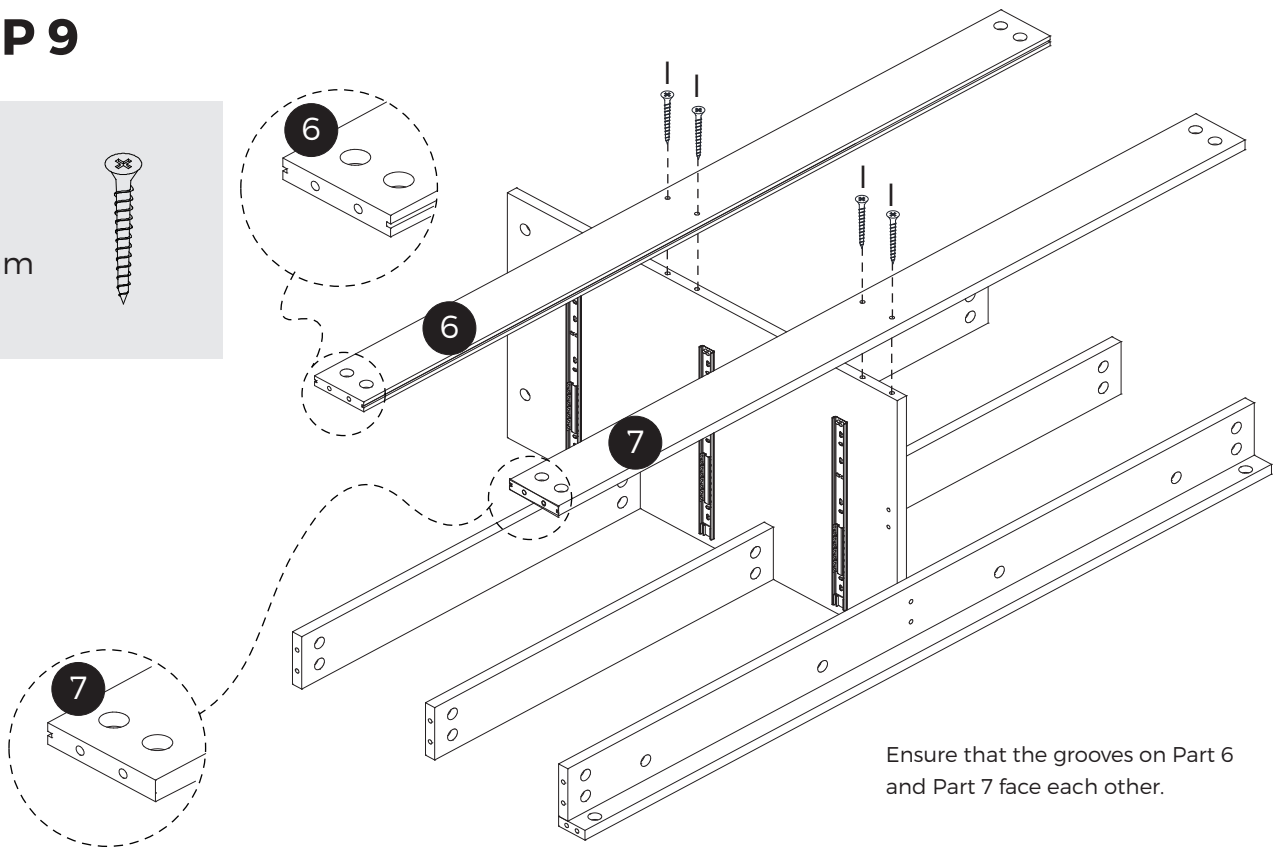

Ensure that the grooves on Part 6 and Part 7 face each other.

## STEP 10

### Part B

11pcs  
15x9.2mm



### Part C

1pc  
6x30mm

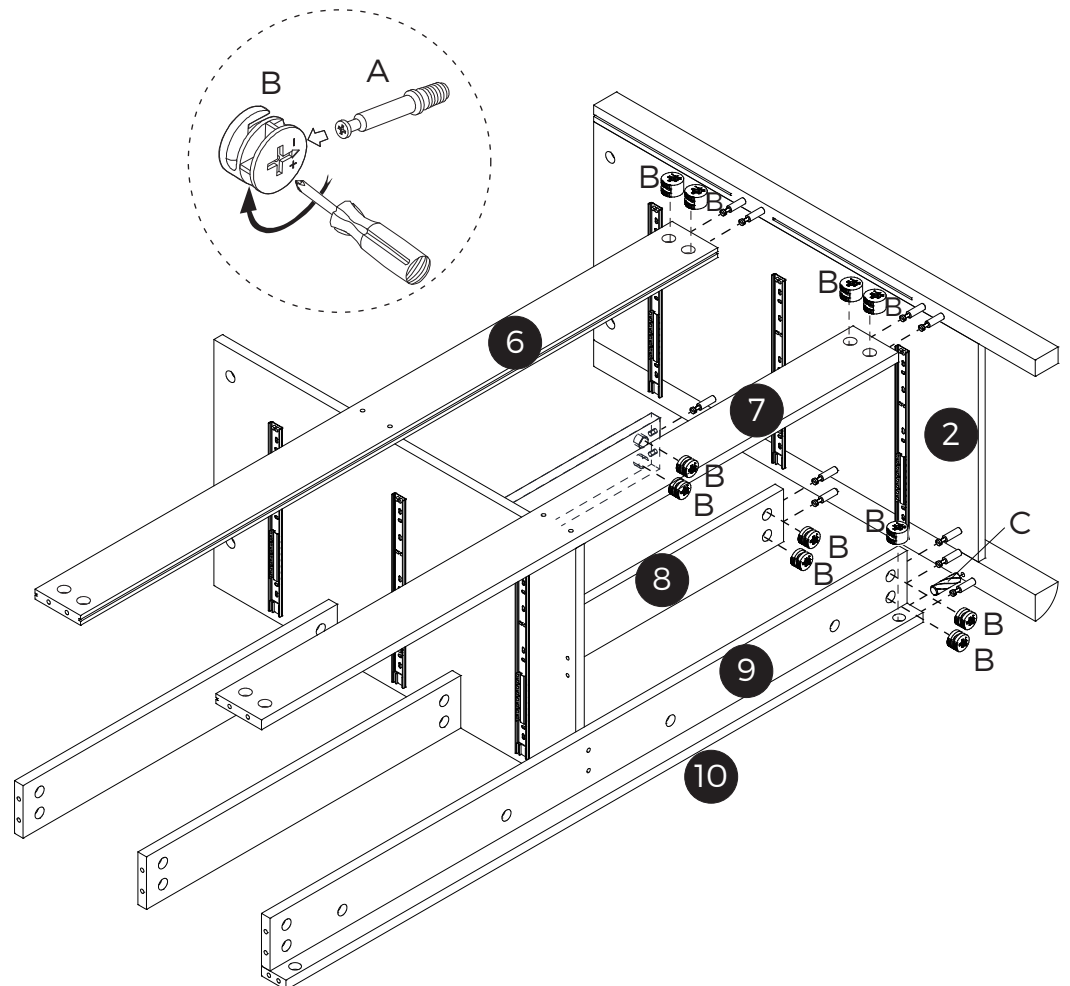
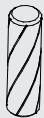

# STEP 11

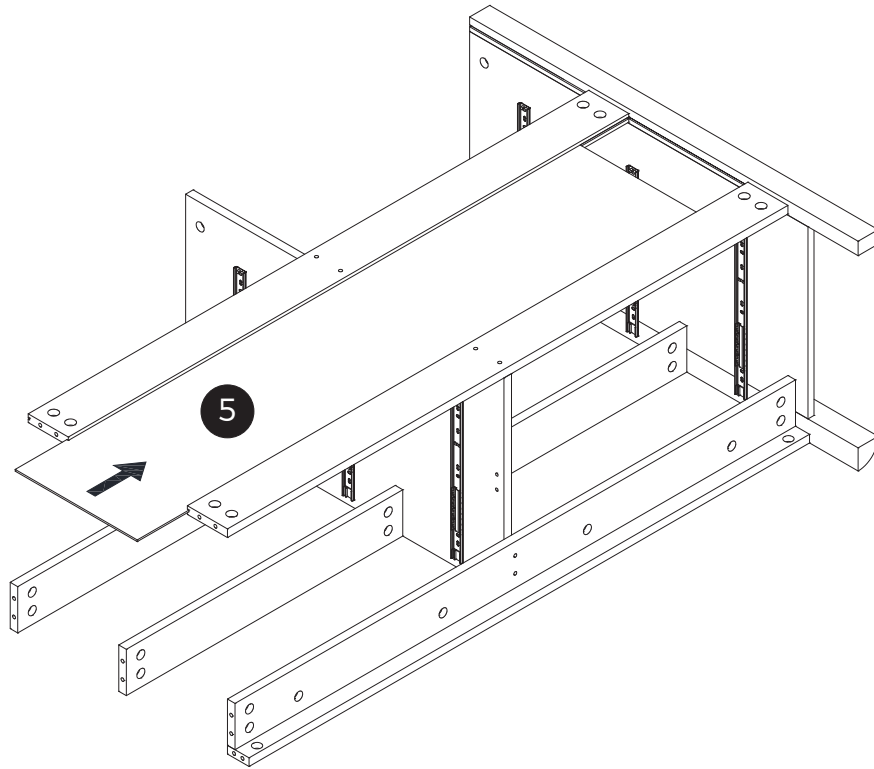

# STEP 12

## Part B

11pcs  
15x9.2mm



## Part C

1pc  
6x30mm

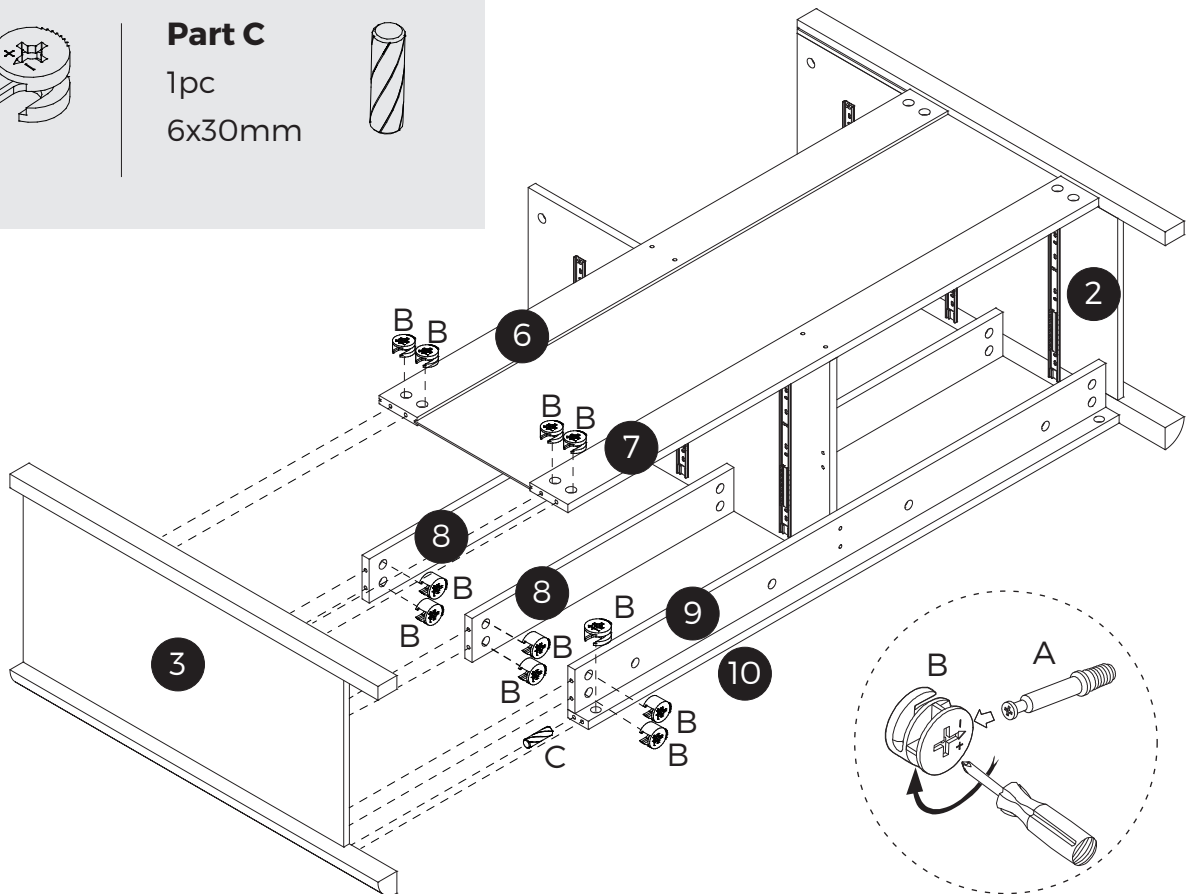
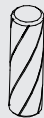

# STEP 13

**Part K**

2pcs



**Part P**

2pcs



**Part Q**

2pcs  
4x10mm

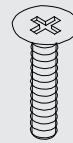

**Part R**

1pc

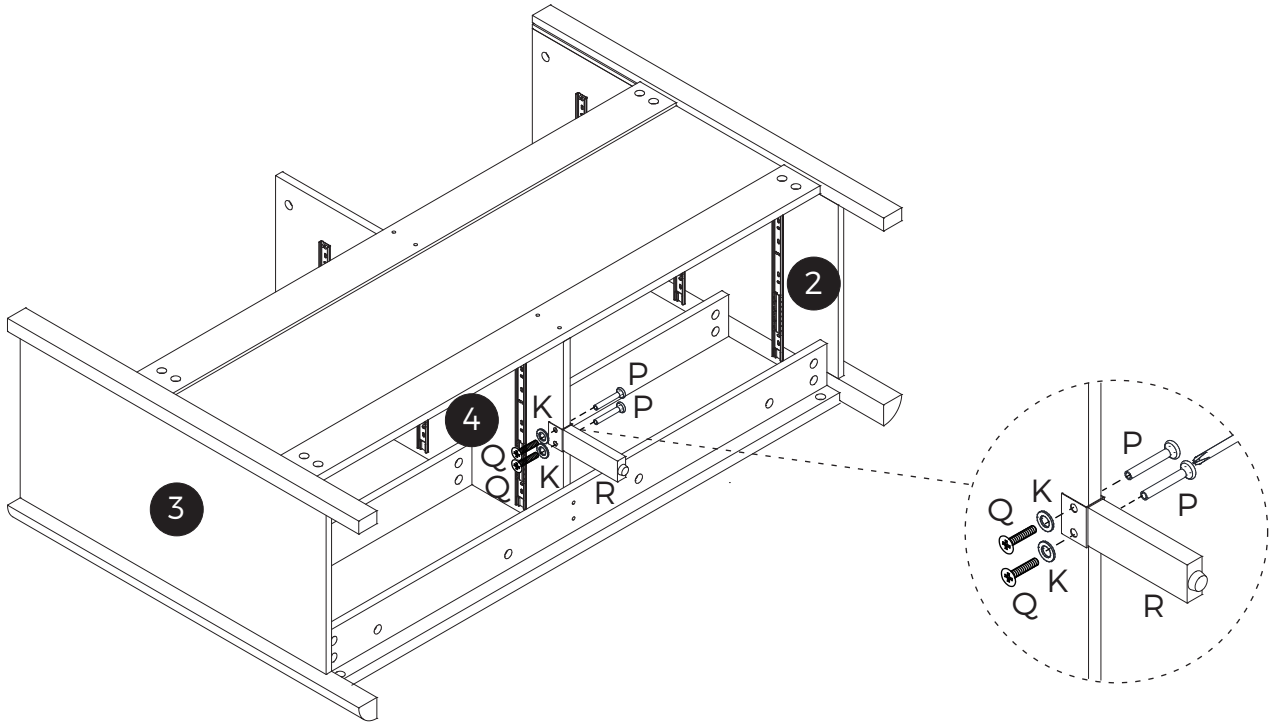

# STEP 14

**Part M**

4pcs

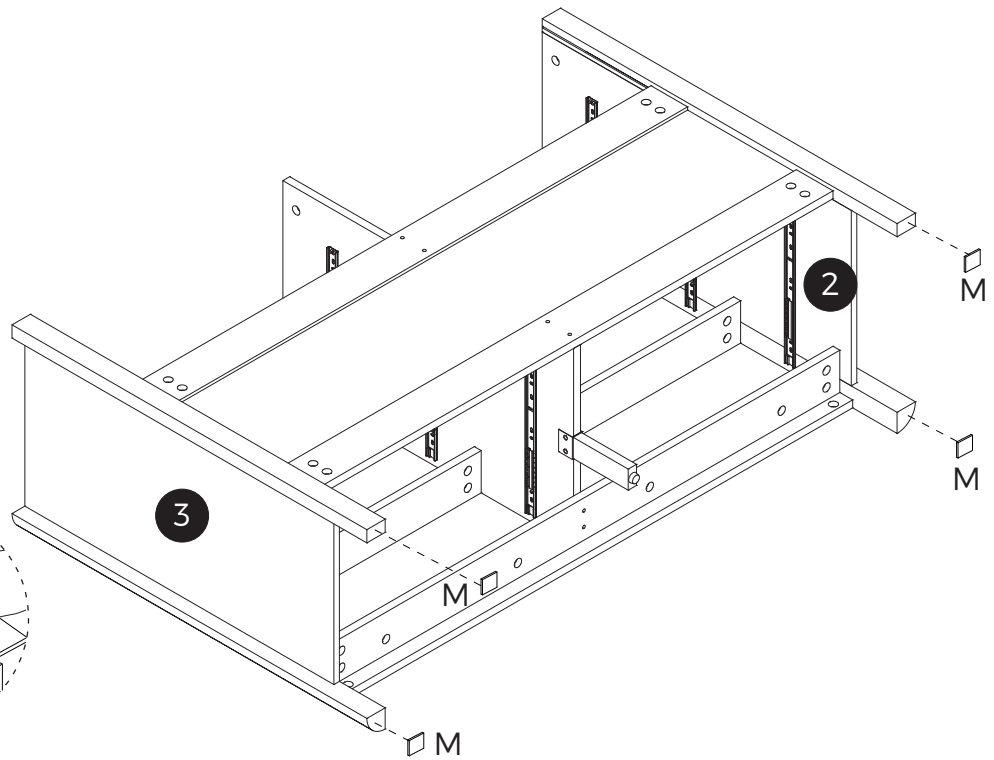
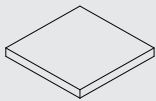

## STEP 15

### Part C

6 pcs  
6x30mm

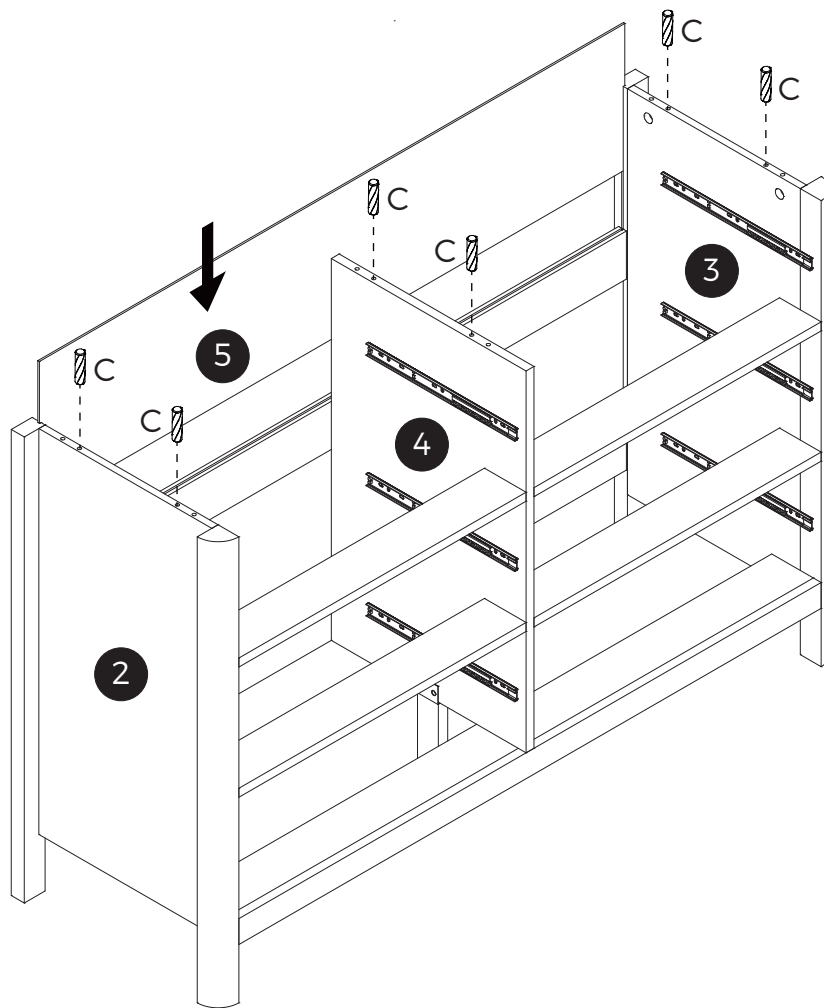

## STEP 16

### Part A

6 pcs  
6x35mm

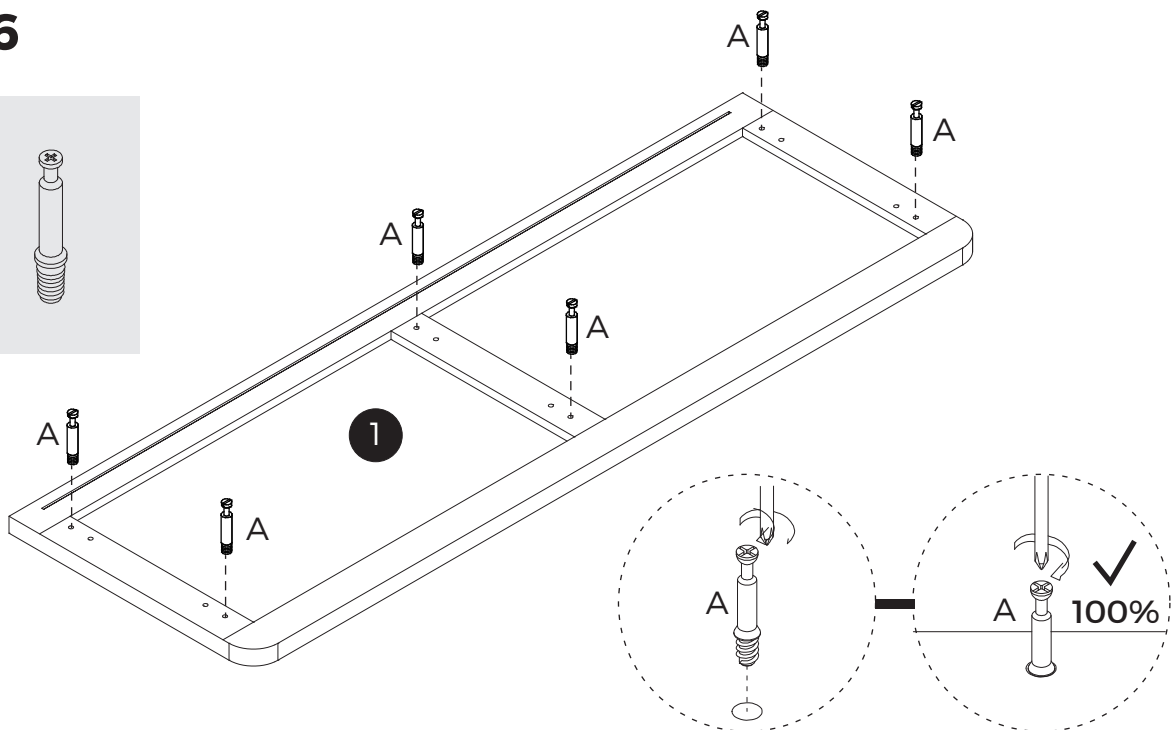

Tighten Part A fully

# STEP 17

## Part B

6pcs

15x9.2mm

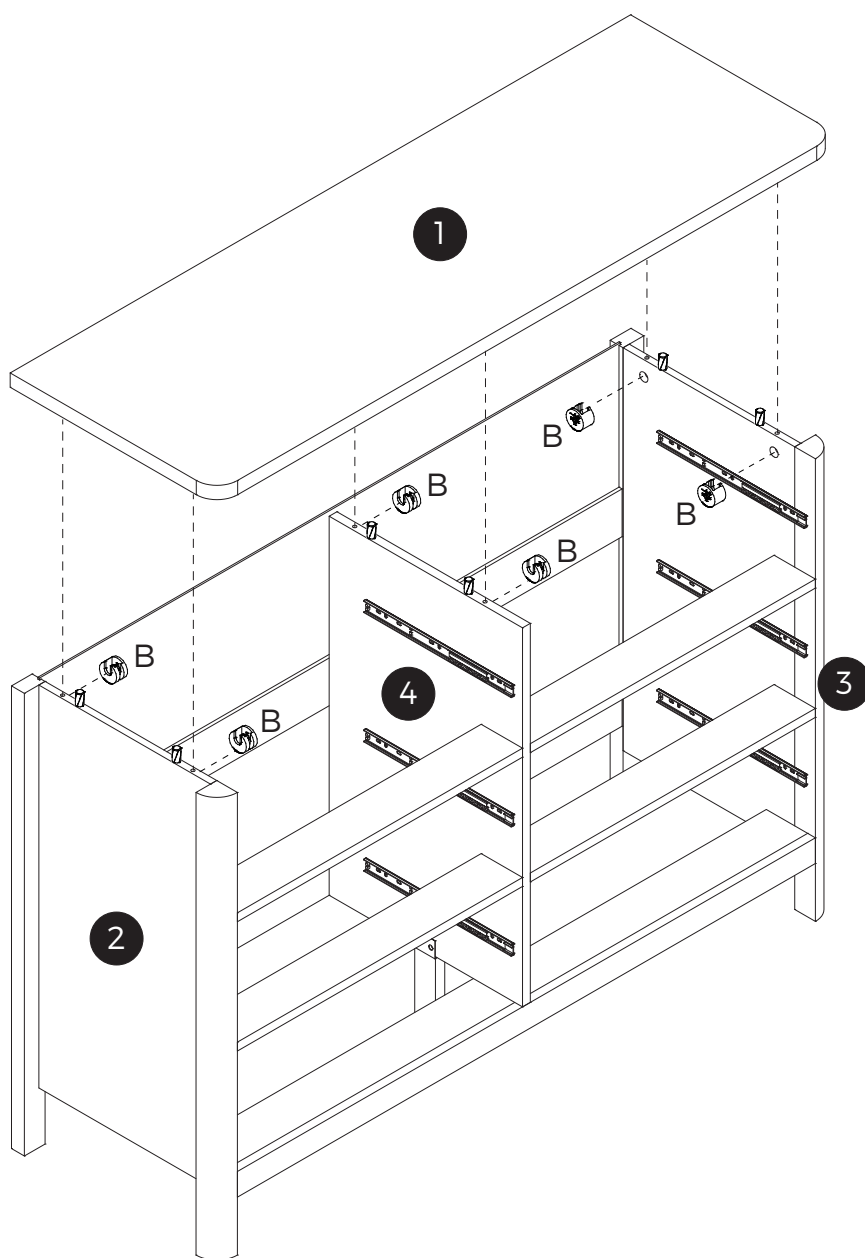
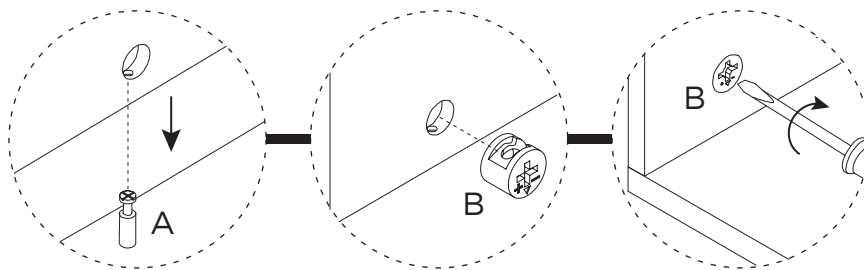
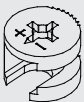

# STEP 18

## Part A

30pcs  
6x35mm

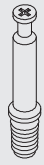

## Part B

30pcs  
15x9.2mm



## Part E

12pcs



## Part F

6pcs



## Part G

6pcs  
4x18mm



## Part H

36pcs  
3x12mm



## Part I

30pcs  
4x35mm



# x6

Assemble 6 drawers

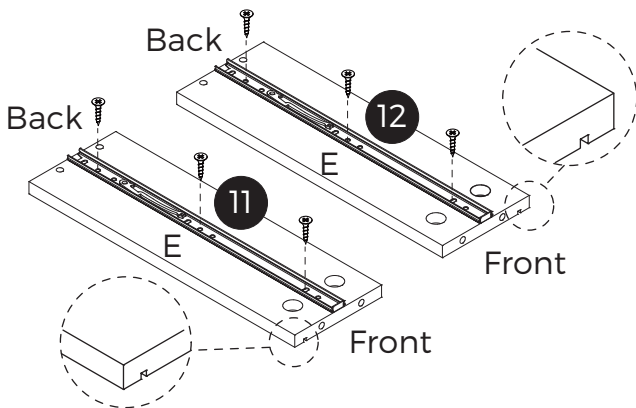

### NOTE:

When installing the drawer runners, fasten the screws H as shown. The screw hole at the front is oval shape to facilitate adjustments to the alignment of the drawer.

**TIP:** It can sometimes take small adjustments to align the drawers correctly.

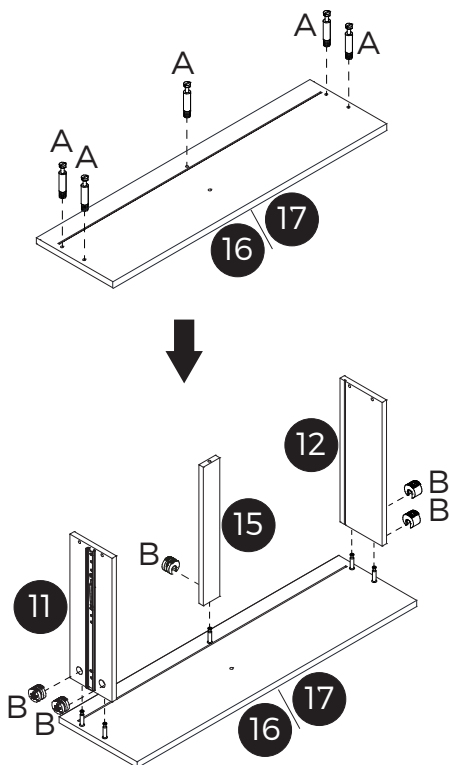

**NOTE:** It is important not to over-tighten screws on the drawer sides until all sides are aligned and the drawer base is inserted. Tighten screws fully once the base is inserted correctly. Always keep the drawer flat in this step so that the groove for the base will align correctly.

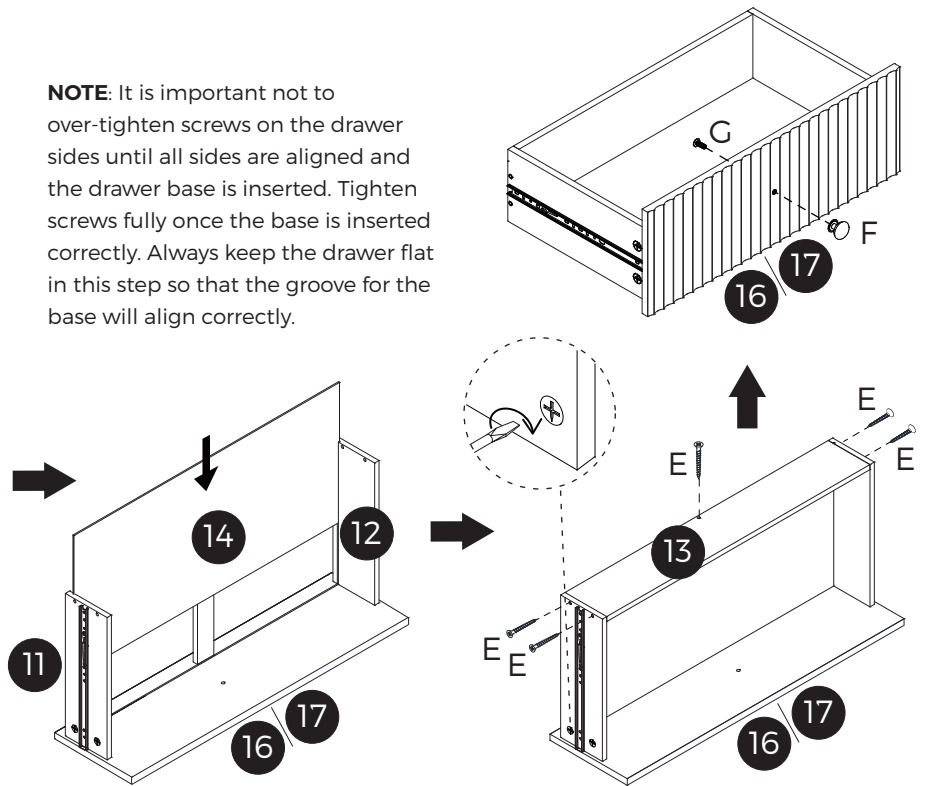

# STEP 19

## Part J

2pcs



## Part K

2pcs



## Part L

2pcs

4x12mm



## Part O

8 sets

3x16mm



### OPTIONAL •

Install Part J only if you wish to secure the product to a wall. See Step 20.

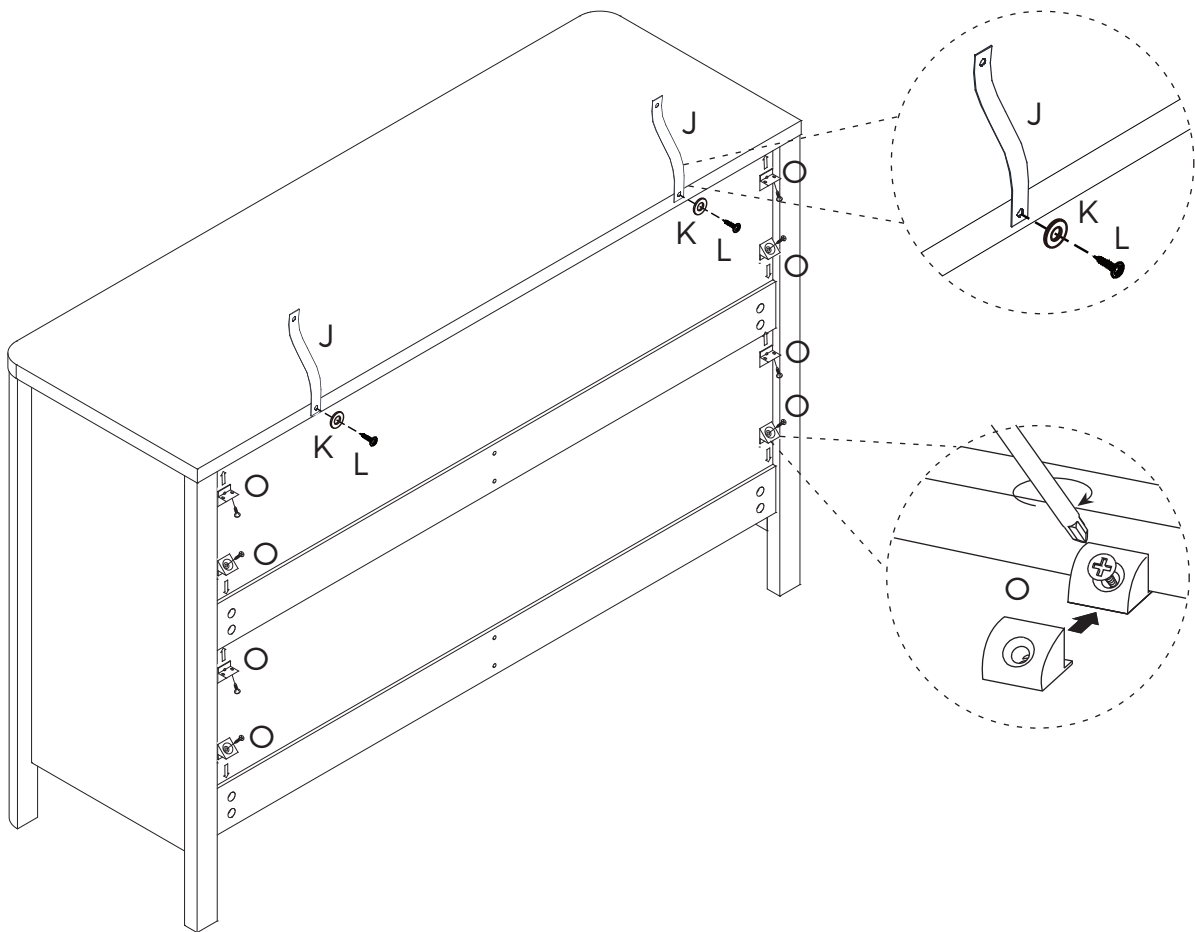

# STEP 12

**Part I**  
2pcs  
4x35mm



**Part K**  
2pcs



**Part N**  
2pcs

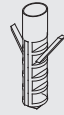

**NOTE**  
Refer to next page  
for drawer installation  
guidelines.

## OPTIONAL

Do this step only if you wish to secure the product to a wall. It is highly recommended that you do so for safety reasons.

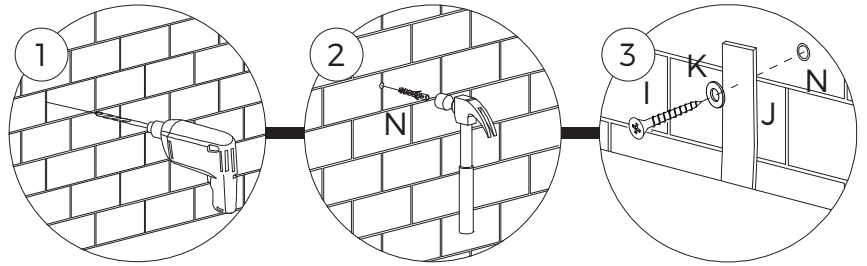

Pre-drill hole in the wall

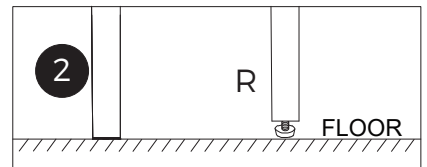
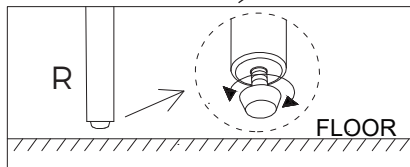
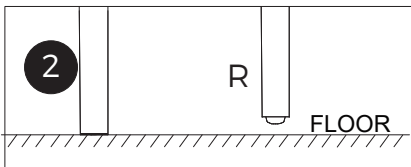
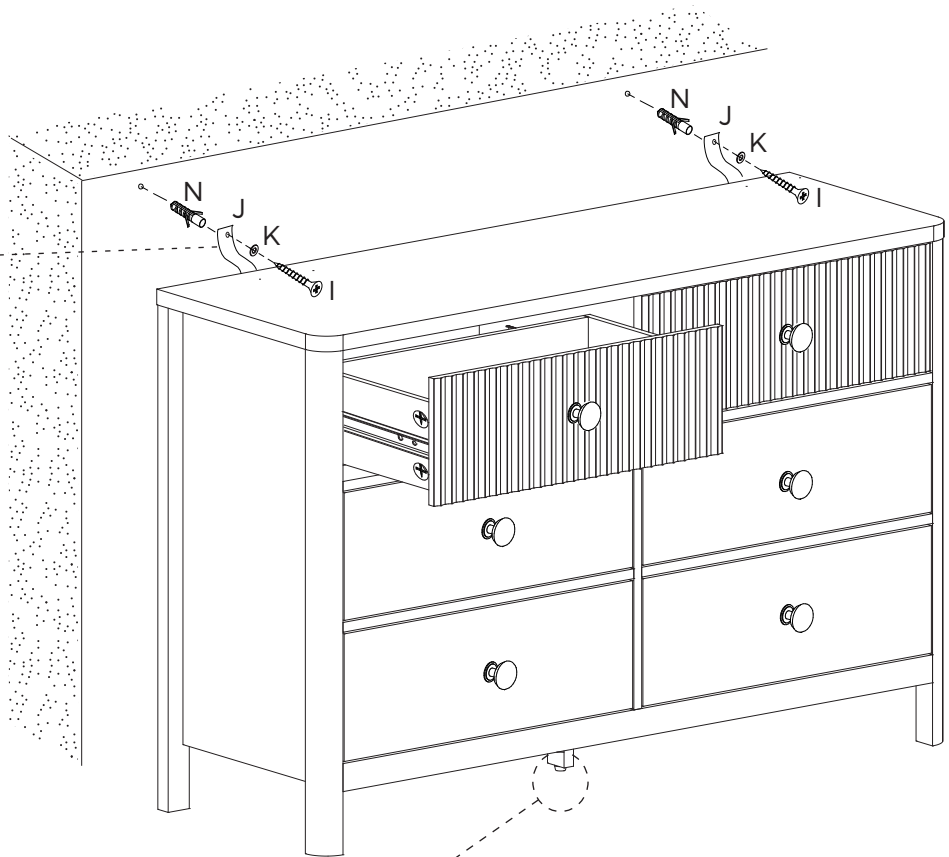
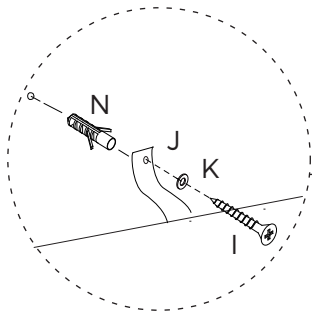

# DRAWER INSTALLATION GUIDE

Before you insert the drawers into the unit, please ensure that the ball bearing sliders (on the assembled unit) have been moved to the front of the main unit. If the bearings are in the middle of the slider, it will be difficult to install the drawers correctly.

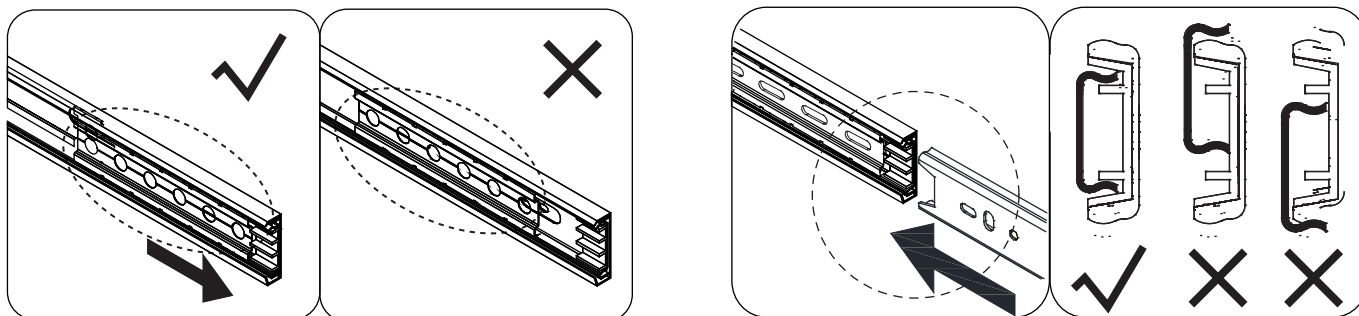

Insert the drawer into the assembled unit as show below. Keep each side of the drawer straight and aligned correctly to the sliders on the assembled unit.

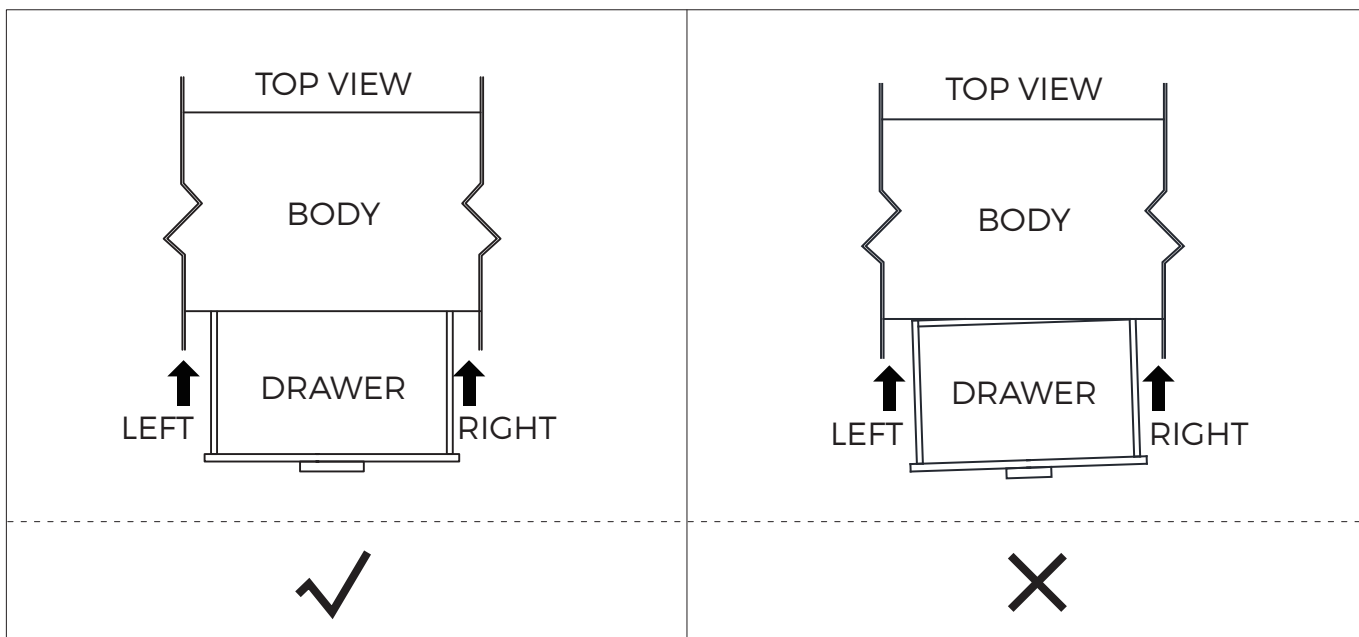

Gently start to push the drawer into position. The drawer sliders should start to connect with the sliders on the assembled unit. Once connected, apply even pressure to each side and gently push the drawer into place.

The ball bearings should lock on to the drawer sliders. Once they do, you may need to apply more pressure. This is perfectly normal as long as the drawers are kept straight. Push the drawers fully in. Finally, slide the drawers in and out a few times to ensure that the ball bearings are functioning smoothly in the sliders.

**At any stage during the installation process and the drawers are not sliding evenly into the unit, remove the drawers before they lock on to the sliders and repeat the installation steps.**

# DRAWER REMOVAL

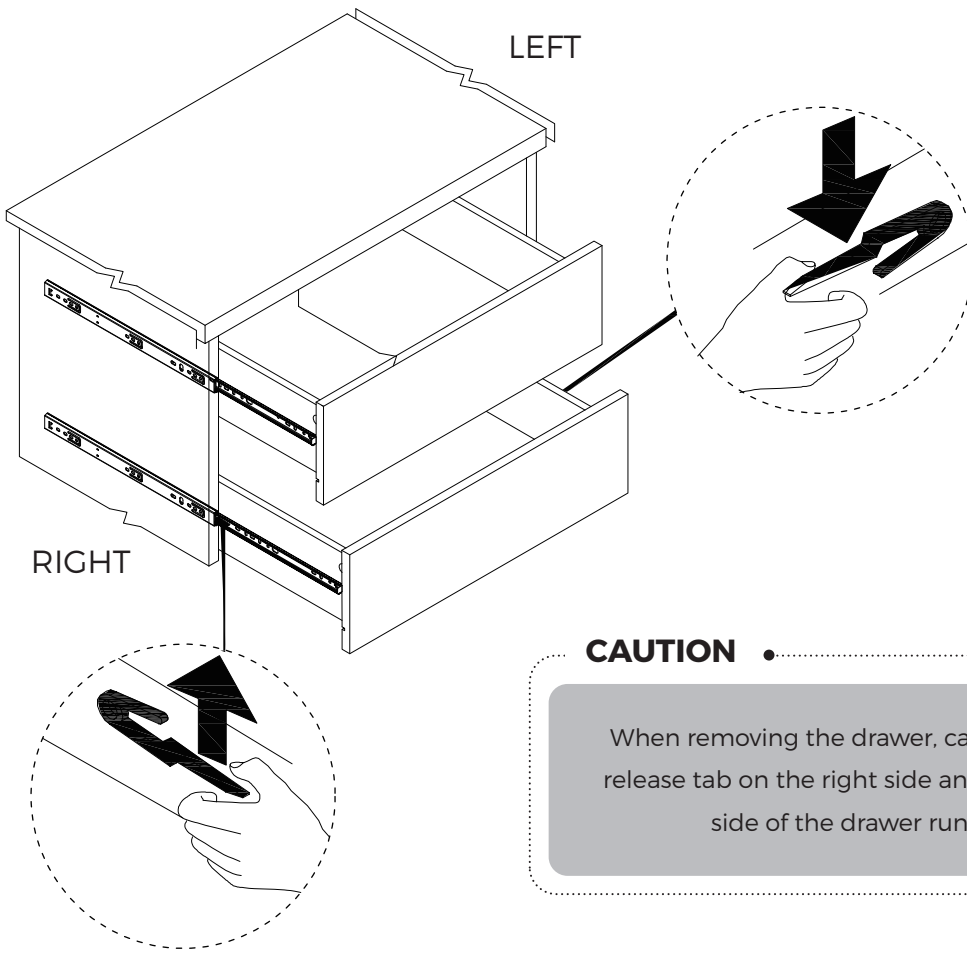

## CAUTION •

When removing the drawer, carefully tip up the safety release tab on the right side and tip it down on the left side of the drawer runners as shown.

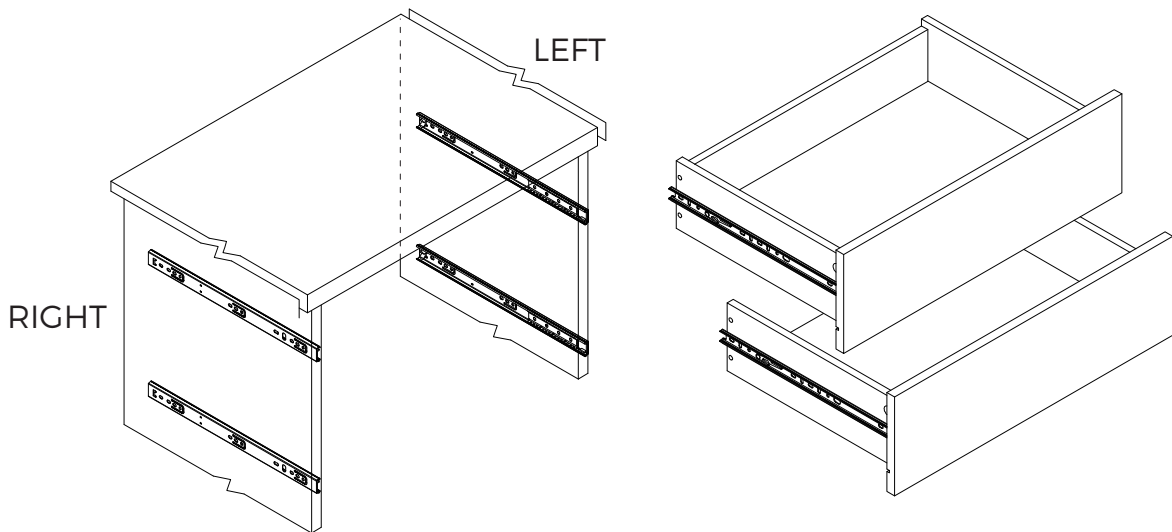

# CARE AND MAINTENANCE

## GENERAL

- Periodically check all screws, bolts and joints connections and tighten them if necessary.
- Periodically check for any damage and deteriorated parts and components and seek repairs or replacements if needed.
- Do not allow any liquids to remain on the furniture as this may cause stains and allow the liquid to be absorbed into the finishes and materials. In some cases, this may also cause warping and/or cracking of the materials and finishes. Use coasters and placemats for all food and beverages.
- Do not place hot items, such as dishes, pots and cups, directly on the furniture. Use coasters and placemats for all food and beverages.
- Keep sharp and pointed objects away from furniture to avoid damaging the surface and finish.
- Do not place the furniture near hot objects, heating vents or heating equipment.
- Do not place the furniture in moist areas, such as bathrooms, to avoid water damage.

## CLEANING AND CARE

- Dust the furniture regularly using a soft cloth or microfibre duster to prevent dust build-up
- Only wipe and clean with a soft, damp cloth with a mild cleaning detergent.
- Do not use abrasive cleaning materials such as scouring pads and chemical cleaning solvents to avoid damage to finishes and paintwork.
- After using or cleaning a glass table top, wipe it completely dry as leaving the glass unattended when wet may leave water marks that cannot be removed easily.
- For upholstery, vacuum regularly with a soft, non-metallic brush to remove dust and grime and to prevent overall soiling. Follow manufacturer's instructions for spot cleaning.
- If removable, wash upholstery covers periodically. If machine washable, use a cold wash cycle.
- Do not use a dryer. Only air dry the upholstery covers.

## ENVIRONMENTAL

- Do not expose the furniture (including outdoor furniture) to direct sunlight. Protect your outdoor furniture with weather-resistant covers, and have curtains and blinds to shield indoor furniture if direct sunlight is unavoidable.
- Bamboo, rattan as well as wood-based furniture are prone to damage and fade with prolonged exposure to extremely high or low humidity conditions. Do not place them in such extreme conditions.
- For outdoor bamboo/rattan furniture, do not place the furniture in shady or moist areas to prevent it from moulding. Bring the furniture indoors during the off season or covered it with weather-resistant covers.

## HANDLING

- Do not drag, push or pull furniture when moving them. Lift them up to avoid damage to the furniture legs and scratches on floors.
- Do not sit or stand on the armrests or use the furniture as a stepping stool for safety reasons.
- Do not exceed the recommended weight capacities of the furniture specified.
- Do not use the furniture for any other purpose other than what is intended for.

## STORAGE

- Store furniture in a clean, dry environment when not in use.
- If possible, disassemble furniture before storing to save space and prevent damage during transportation.

## SPECIFIC CARE

- Engage professional upholstery cleaning services for deeper cleaning if required.
- For genuine leather, suede leather or synthetic leather upholstery, use an appropriate leather conditioner to maintain its suppleness and appearance and prevent drying and cracking. The conditioner also adds a thin protective layer on the leather surface to facilitate easier cleaning.
- If a furniture polish is used for wooden furniture, make sure that it is of low alcohol content.
- To prevent rattan from becoming dry and brittle, spray water on the underside of the furniture piece every six months and wipe down with a dry cloth to remove excess water.
- As an optional protection for bamboo furniture, apply a bamboo sealant/varnish on it for durable protection against scratches, water, UV rays and other weather elements.

**⚠ WARNING**

	
--	---

**Children have died from furniture tipover.**

- ALWAYS secure this furniture with an anchor device.
- NEVER allow children to stand, climb or hang on drawers, doors, or shelves.
- NEVER open more than one drawer at a time.
- Place heavy items down low.

**NEVER put a TV on this furniture** 