

Assembly Instruction

SOF-ROBIN series



IMPORTANT NOTE:

- * PLACE ALL PARTS ON A CLEAN AND SMOOTH SURFACE SUCH AS A RUG OR CARPET TO AVOID THE PARTS FROM BEING SCRATCHED.
- * KINDLY FOLLOW THE ASSEMBLY INSTRUCTIONS STEP BY STEP.

ASSEMBLY CHECKLIST



Read through the instructions carefully before starting assembly.



Make sure that you have the required tools. Do not use power tools.



Identify and lay out all parts to familiarise yourself with them.



Do not fully tighten all screws until the step or process has been completed.

USEFUL INFORMATION

1. Never use power tools for assembly. They can damage the components or hardware if used incorrectly.
2. The most common mistakes made during assembly are using the wrong hardware or getting components from back to front.
3. Always assemble the product on a soft surface such as a carpet or cardboard to avoid scratching or damaging the surface of the product.

Warning:

Do not jump on the sofa, Or it will damage the sofa or cause injury!

Weight load capacity of each Seat: 120KG

Cushion fluff:

Your cushions and pillows come vacuum packed and sealed for shipping. For restoring the cushions and pillows to original shape. Follow the steps below.

We recommend fluffing your pillow by hand for at least 30 seconds by:
Fluffing diagonally.
Hold diagonal corners of your pillow and clap them together. Don't clap too hard, though, because you might actually make your pillow flatter with too much force.

How to Fluff a Pillow with the Accordion Method



- 1 Hold your pillow in the air with both hands from either side.
- 2 Gently compress opposite sides, as if playing the accordion.
- 3 Rotate and repeat this action for an even fluff.

Assembly Instruction

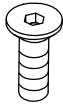

M8*18
A. x 24

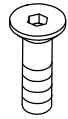

M8*40
B. x 6

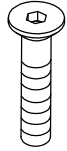

M8*50
C. x 4

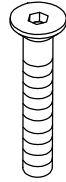

M8*65
D. x 1

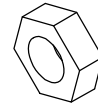

M8
E. x 1

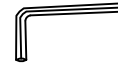

M6
F. x 1

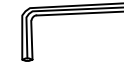

M8
G. x 1



M8
H. x 1



M6*18
J. x 8

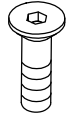

M8*35
K. x 4

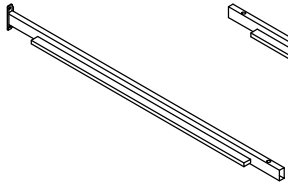

1. x 2

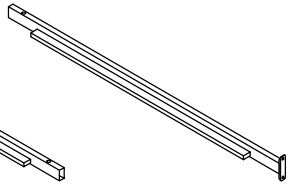

2. x 2

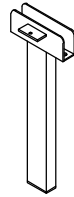

3. x 2

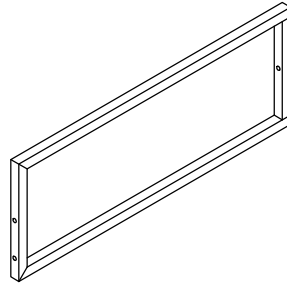

4. x 2

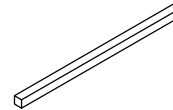

5. x 2



6. x 8

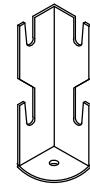

8. x 4

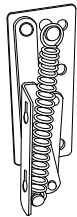

9. x 1

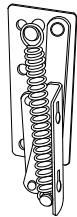

10. x 1

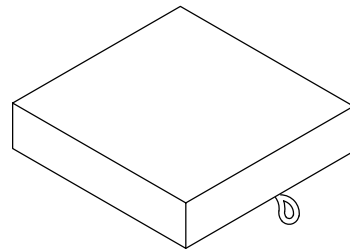

11. x 1

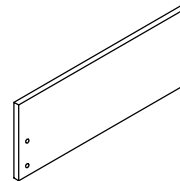

12. x 2

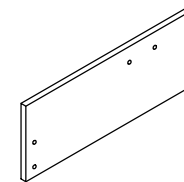

13. x 1

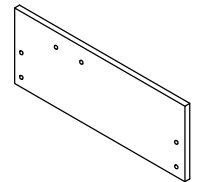

14. x 1

Assembly Instruction

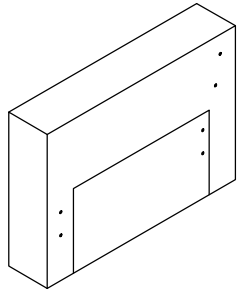

15. x1

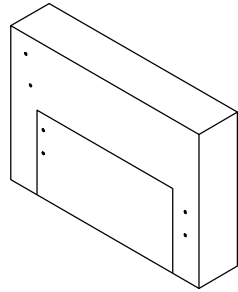

16. x1

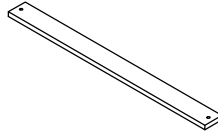

17. x1

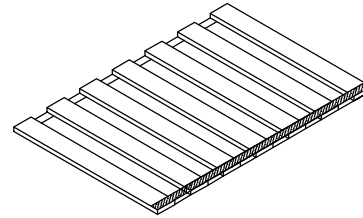

18. x2

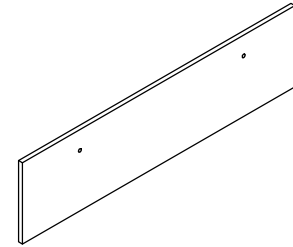

19. x2

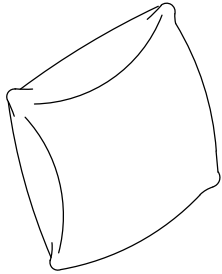

20. x2

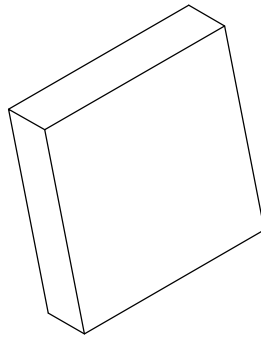

21. x3

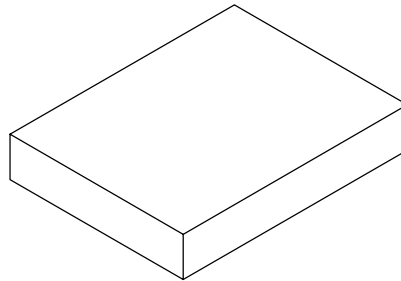

22. x3

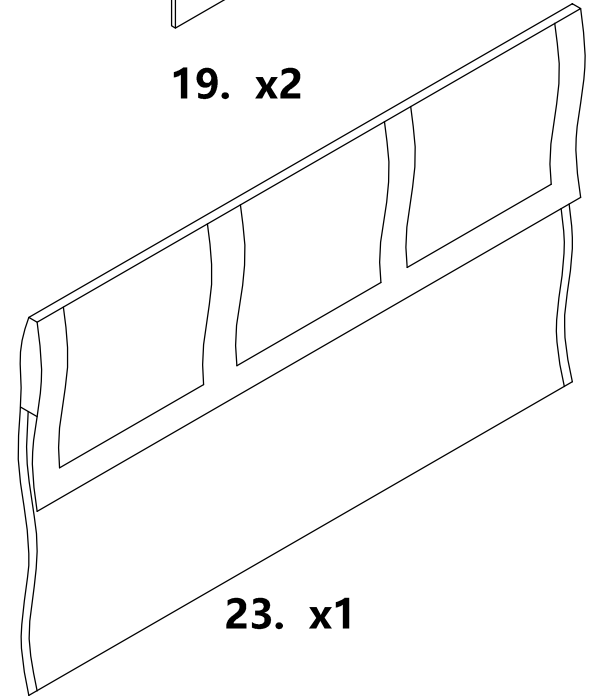

23. x1

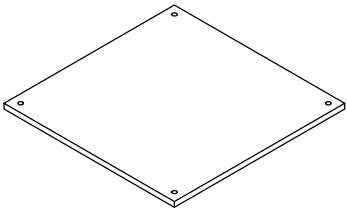

24. x1



25. x4

Assembly Instruction

Step:1

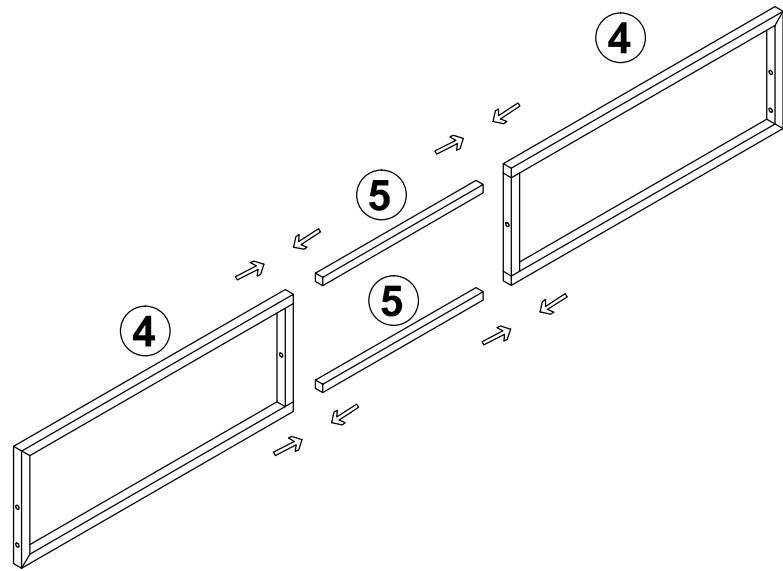

Step:2

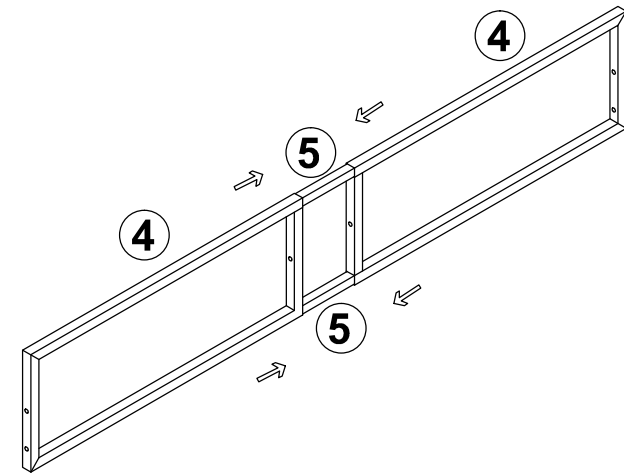

Step:3

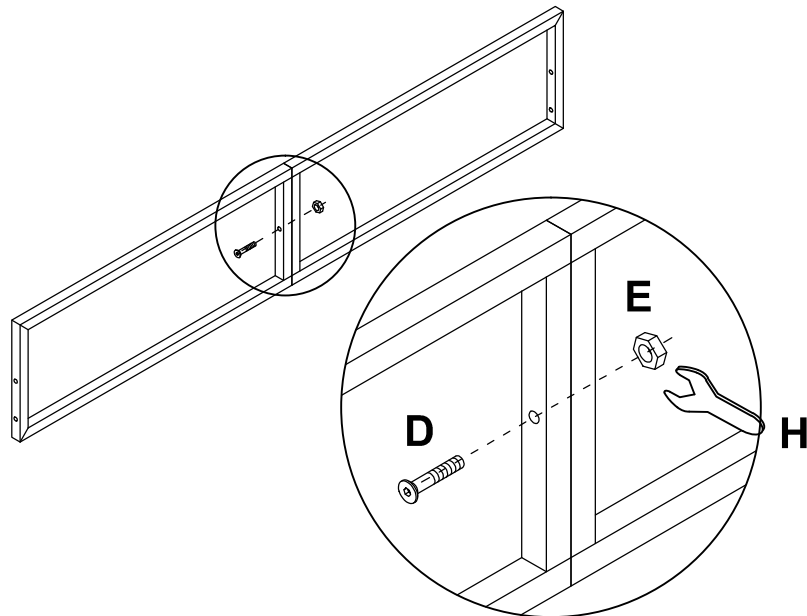

Step:4

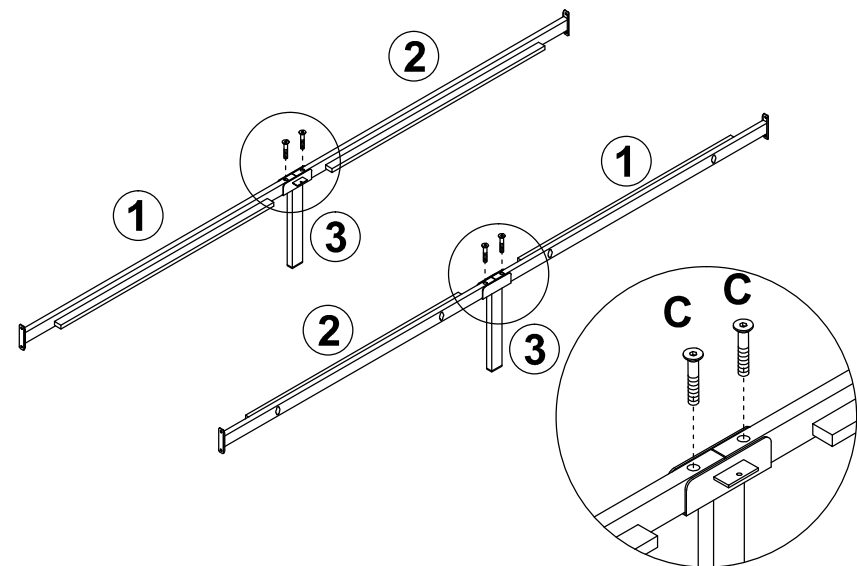

Assembly Instruction

Step:5

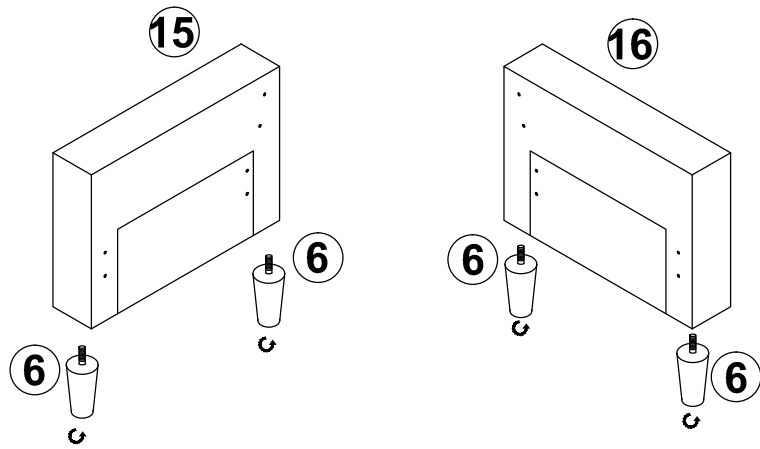

Step:6

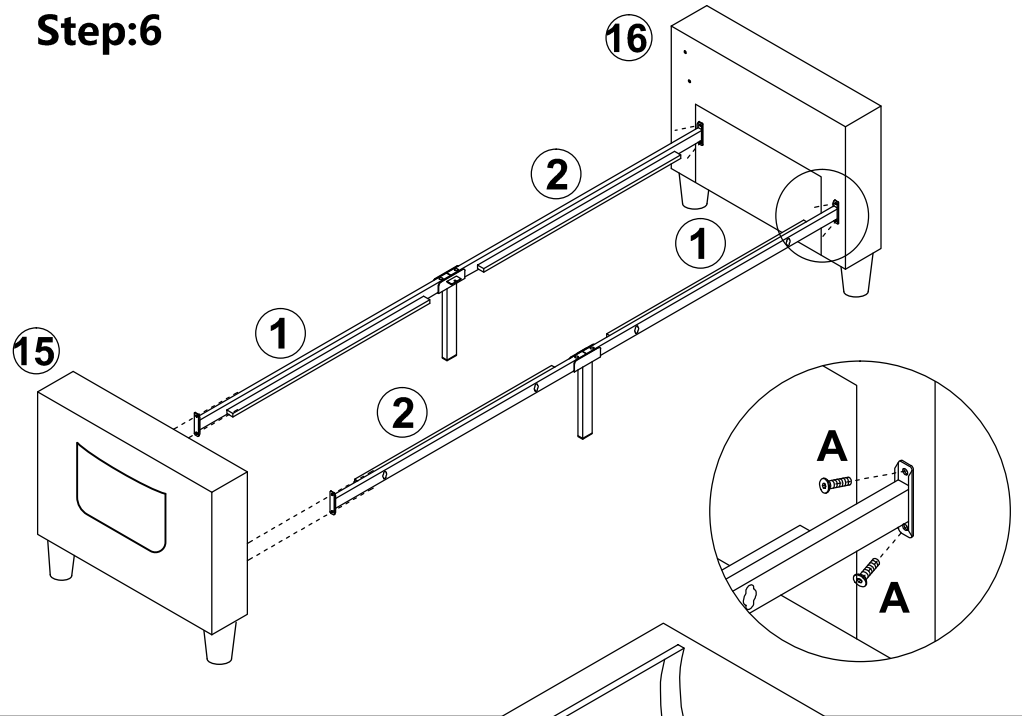

Step:7

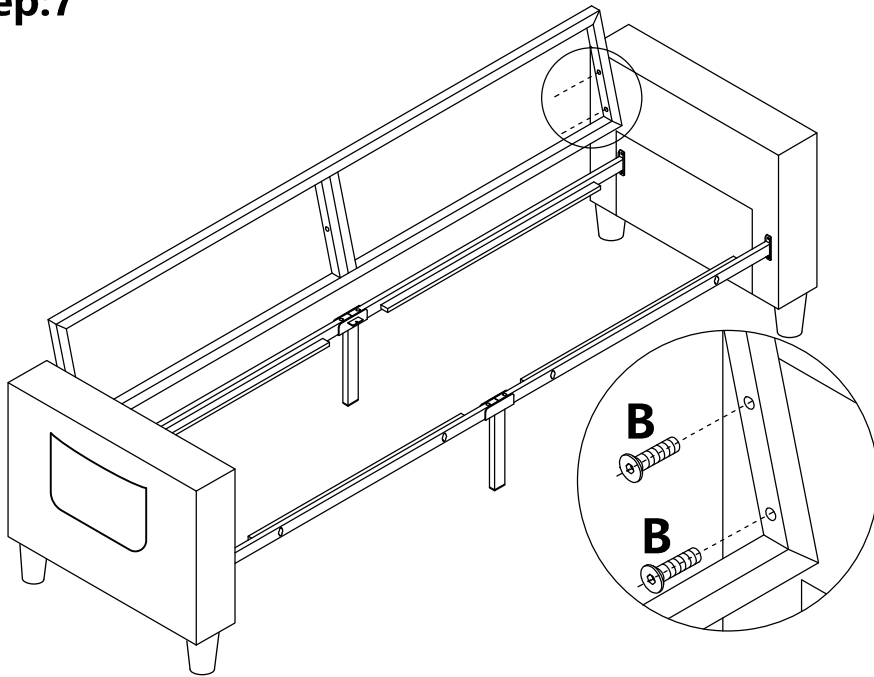

Step:8

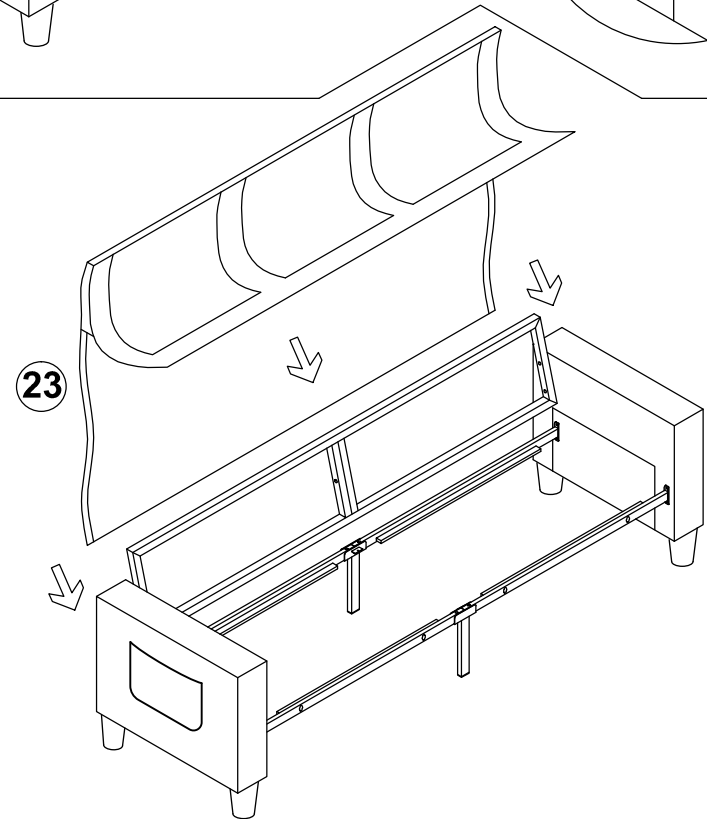

Assembly Instruction

Step:9

There are also Velcro straps that come down from behind the armrest, and the fabric cover can be fully glued to the back of the armrest

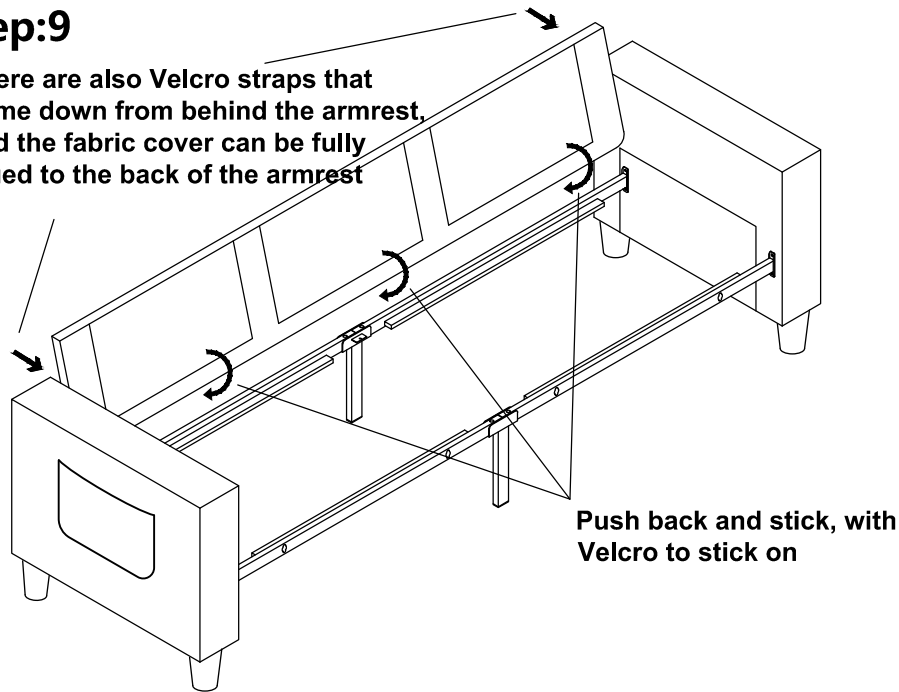

Step:10

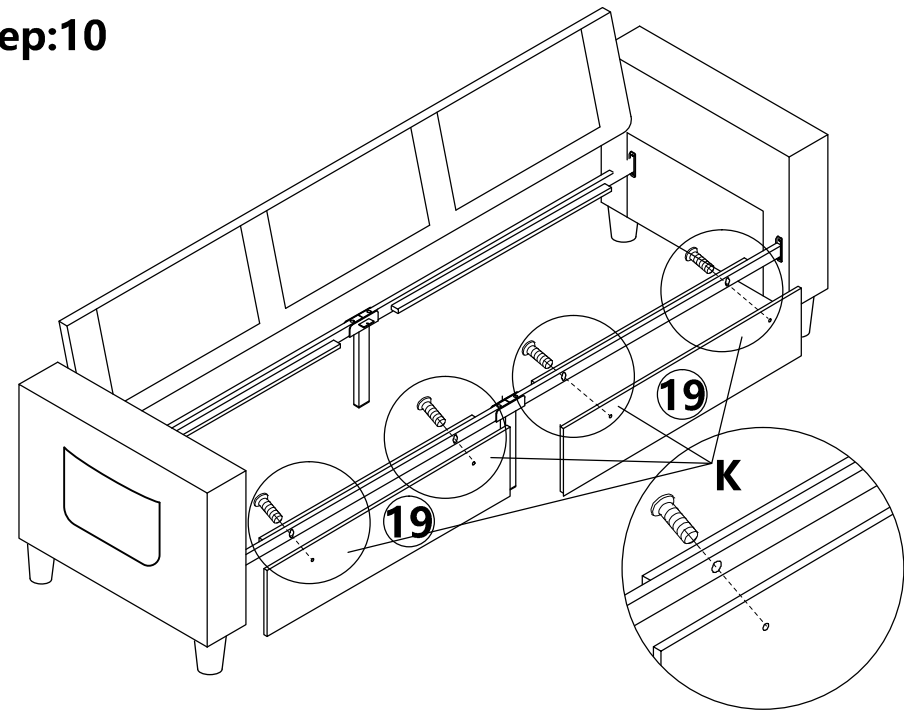

Step:11

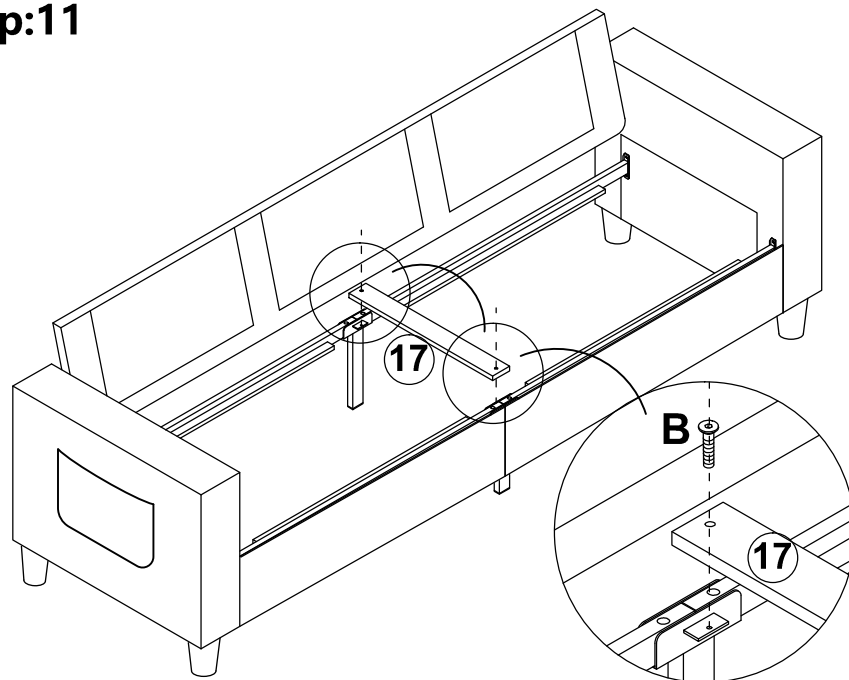

Step:12

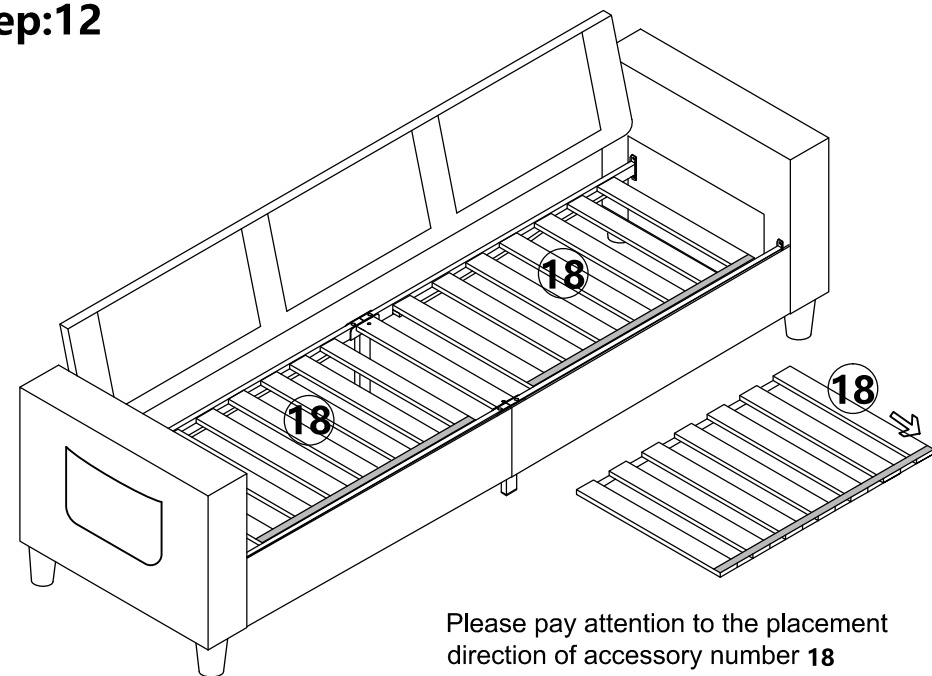

Assembly Instruction

Step:13

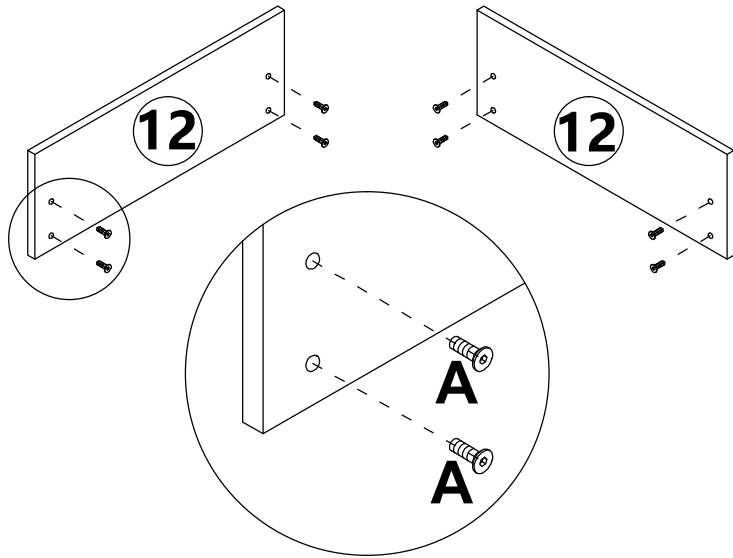

Step:14

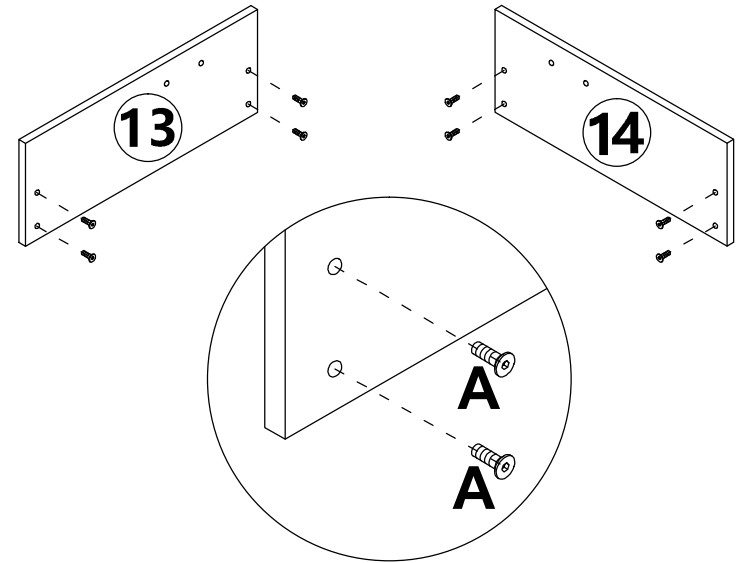

Step:15

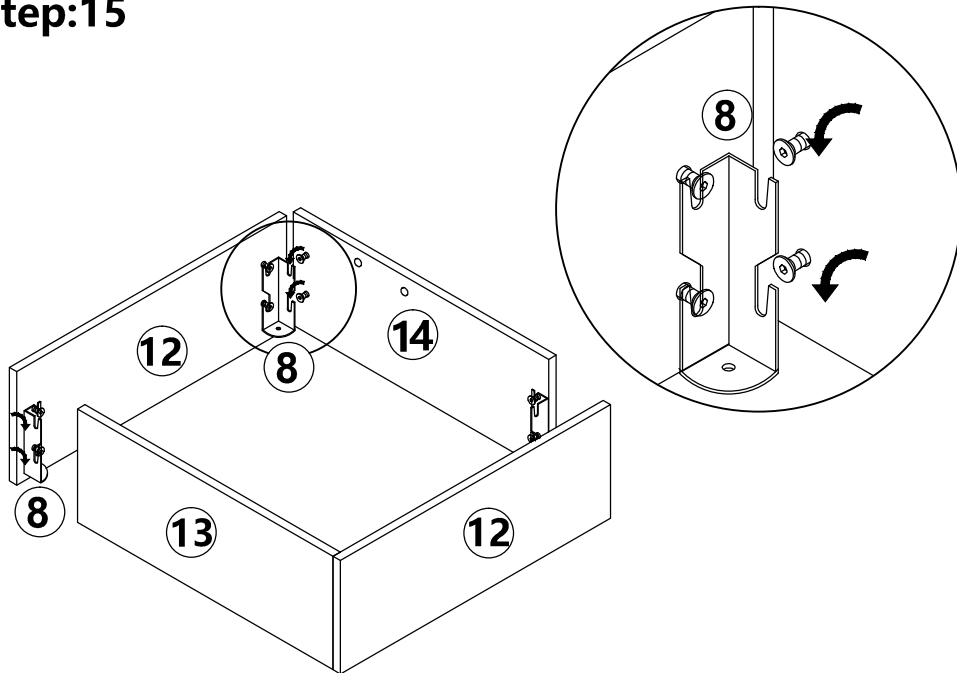

Step:16

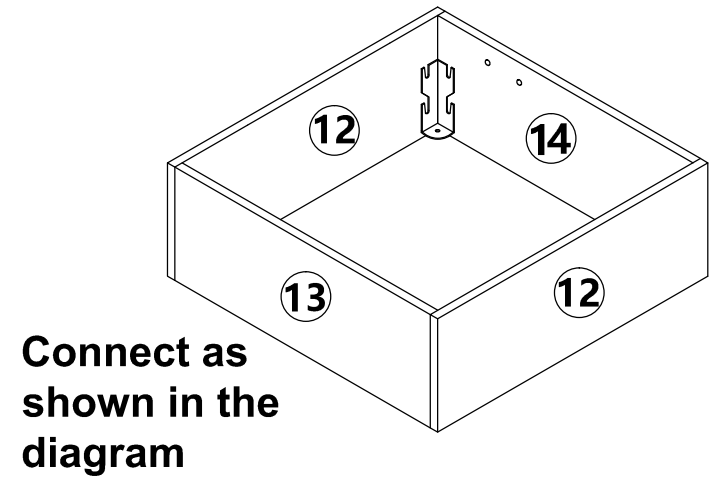

Assembly Instruction

Step:17

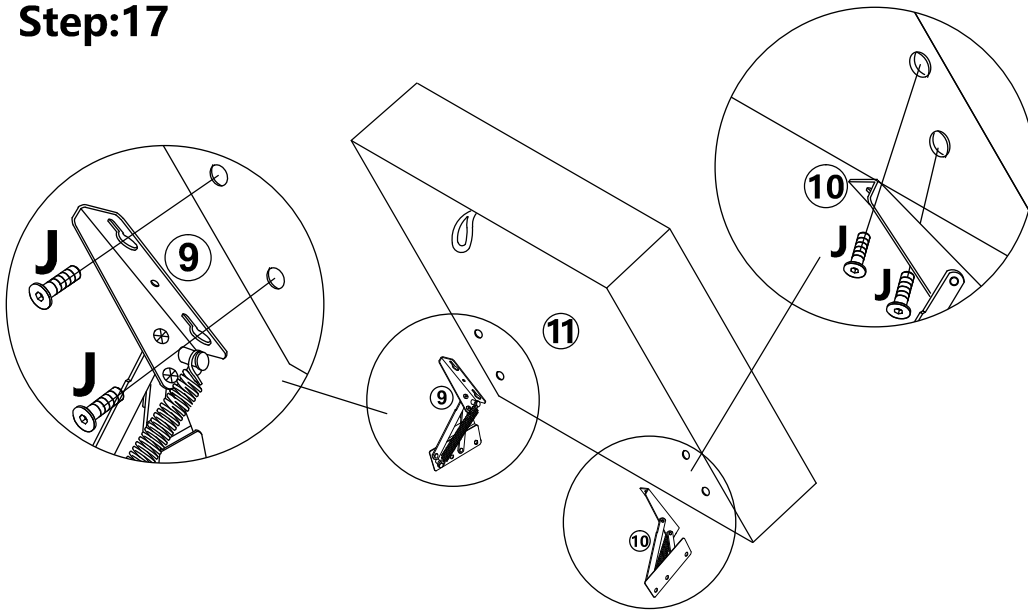

Step:18

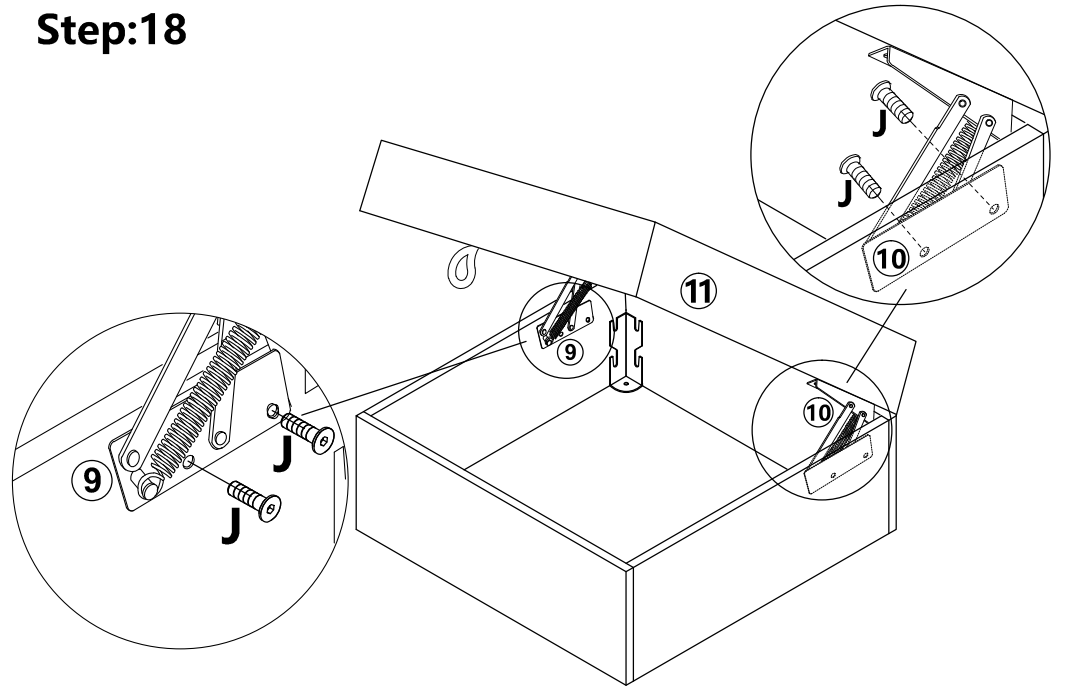

Step:19

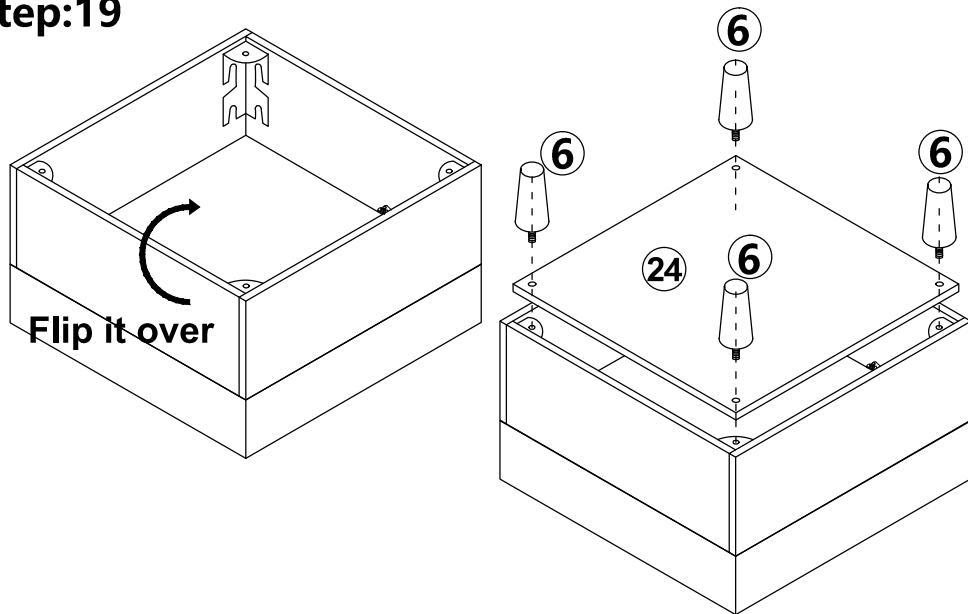

Step:20

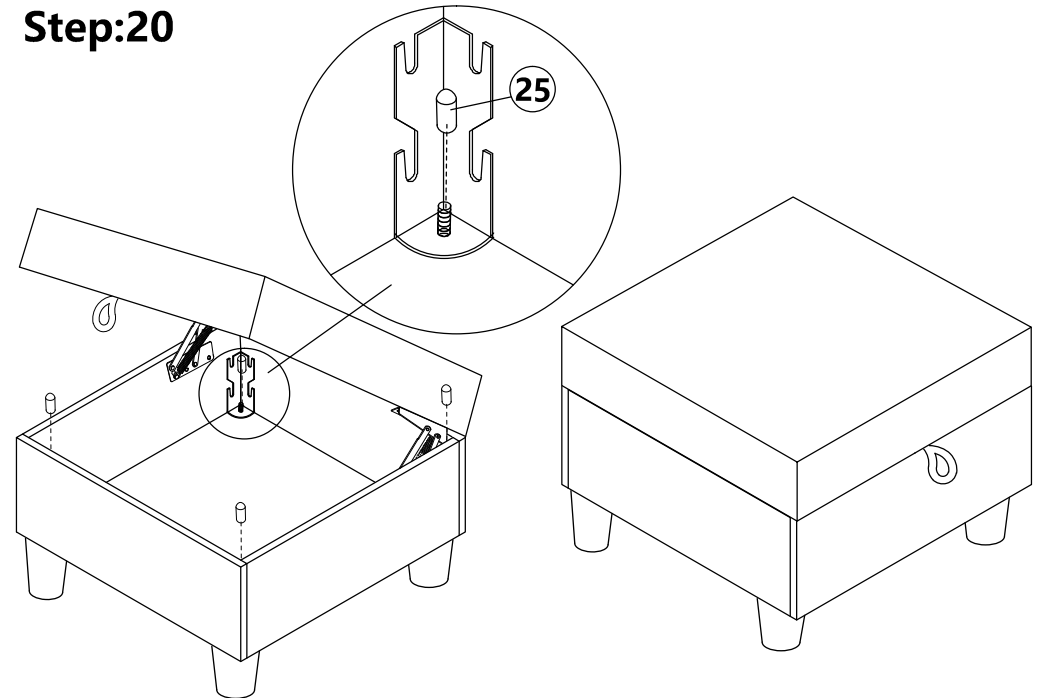

Assembly Instruction

Step:21

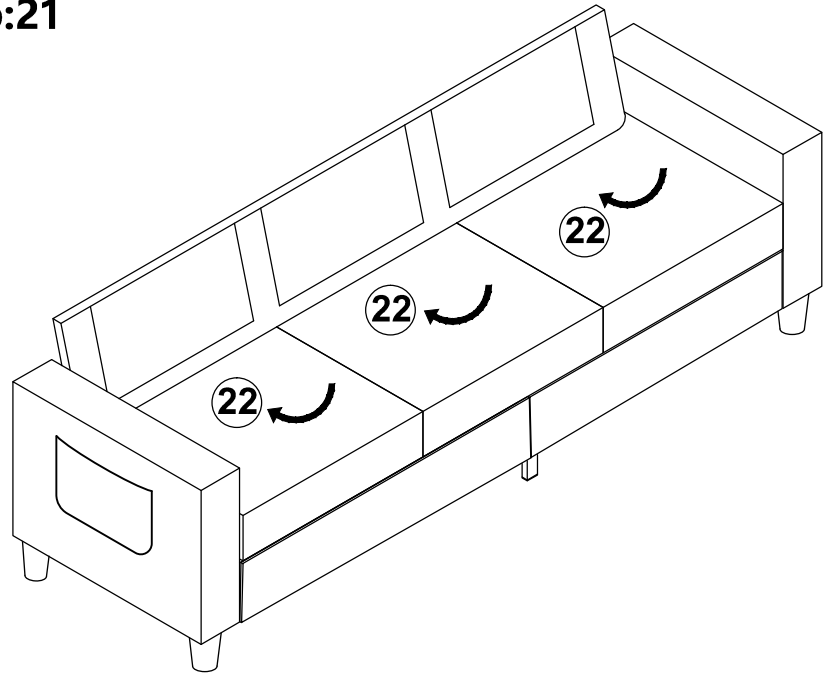

Step:22

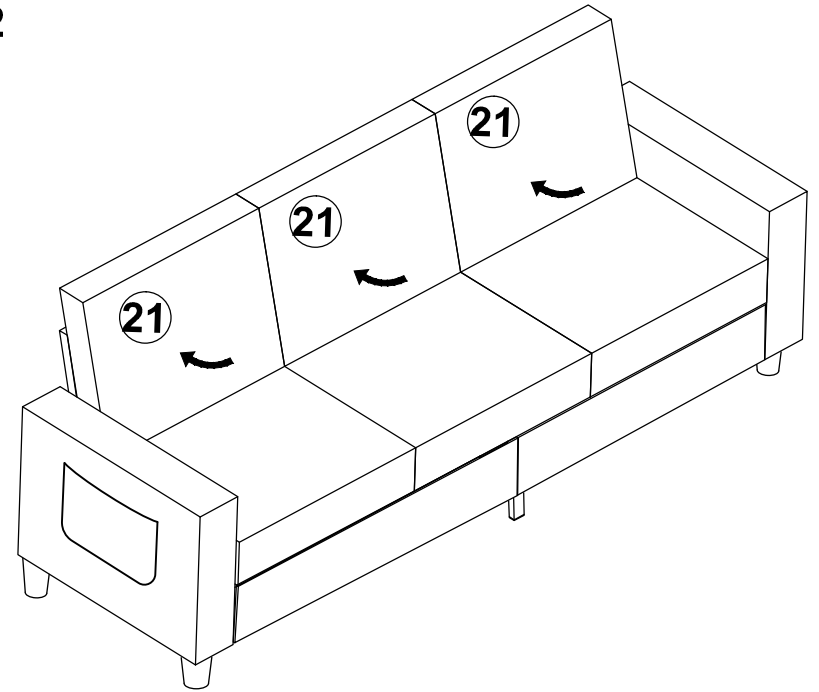

Step:23

