

# TR - SERIES TOWEL RAILS



**HYDROTHERM**  
T O W E L   R A I L S

ver. 2021-4

## TR - SERIES TOWEL RAIL

Hydrotherm are the leaders in design and manufacturing of heated towel rails. Our exquisite range of products are prepared and finished to suit your individual design specifications. Our proven combination of cutting edge designs and finest quality materials make Hydrotherm heated towel rails the ultimate bathroom accessory.

The TR series perfects simplistic design and practicality. The evenly spaced rails make the TR Series ideal for drying towels. Its generous gaps allow bulky fabrics to be draped over with ease.



### TR 1 MODEL

**Standard Height**

700mm + Hardwire

**Available Widths**

400, 500, 600, 700, 800mm

**Wattage**

70 - 150 Watt



### TR 2 MODEL

**Standard Height**

1020mm + Hardwire

**Available Widths**

400, 500, 600, 700, 800mm

**Wattage**

100 - 200 Watt



### TR 3 MODEL

**Standard Height**

1500mm + Hardwire

**Available Widths**

400, 500, 600, 700, 800mm

**Wattage**

150 - 250 Watt

## STANDARD SPECIFICATIONS

<b>Tube Diameter</b> Vertical 25mm / Horizontal 19mm	<b>Materials</b> Copper tube with brass fittings	<b>Element</b> Low wattage, water element replaceable	<b>Power Cable</b> Bottom of unit (only) left or right hand side	<b>Safety Rating</b> IPX5 (allows for installation in zone 1 & 2 of bathrooms)
--	--	---	--	--

## FINISHES & POWDER COAT OPTIONS



**Polished Chrome**



**Matt Black**



**Brushed Nickel**

**Custom Colours available upon request**



**PROUDLY AUSTRALIAN  
MADE AND OWNED**

Widths measured from centre to centre of vertical tube. Allow an extra 40mm in total when measuring total width of unit mounted.

## TR 1 MODEL Electric or Non-heated

## SPECIFICATIONS

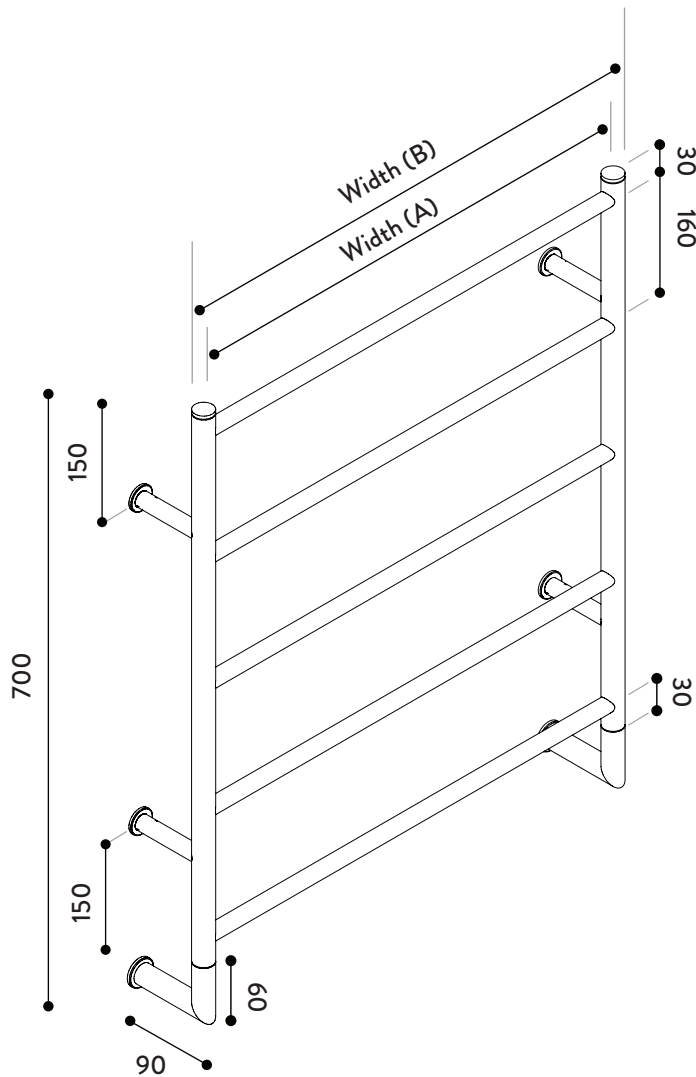

### Height

700mm + Hardwire

### Width Options

400, 500, 600, 700, 800mm

### Tube Diameter

Vertical 25mm / Horizontal 19mm

### Safety Rating

IPX5 (allows for installation in zone 1 & 2 of bathrooms)

### Finishes

Electroplate / Powder Coat

### Output

70 - 150 Watt

### Materials

Copper tube with brass fittings

### Standards

AS/NZS:3350

## KEY FEATURES

### Replaceable Element

Heating element easily replaced

### Copper Tube

Ensures ultimate thermal conductivity and radiant heat

### Style and Simplicity

Perfects minimalist design and practicality.

Generous gaps allow bulky fabrics to be draped over with ease

## VARIATIONS

Electric	Height	Width (A)	Width (B)	Chrome Wattage	P/Coat Wattage
TR1/400	700mm	400mm	440mm	70 Watts	100 Watts
TR1/500	700mm	500mm	540mm	100 Watts	150 Watts
TR1/600	700mm	600mm	640mm	100 Watts	150 Watts
TR1/700	700mm	700mm	740mm	100 Watts	200 Watts
TR1/800	700mm	800mm	840mm	150 Watts	200 Watts



PROUDLY AUSTRALIAN  
MADE AND OWNED



**3 YEAR**  
ELECTRIC ELEMENT  
MANUFACTURERS WARRANTY



**10 YEAR**  
CONSTRUCTION & FINISH  
MANUFACTURERS WARRANTY

## TR 2 MODEL Electric or Non-heated

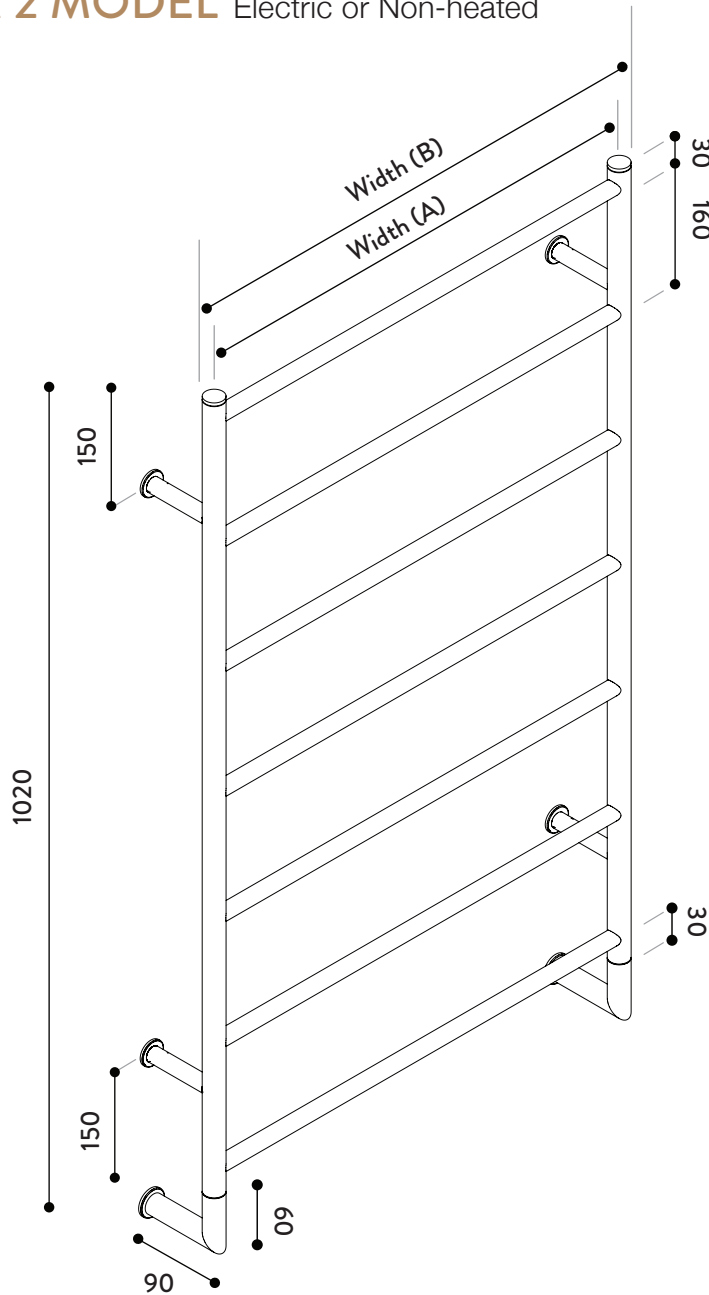

## SPECIFICATIONS

### Height

1020mm + Hardwire

### Width Options

400, 500, 600, 700, 800mm

### Tube Diameter

Vertical 25mm / Horizontal 19mm

### Safety Rating

IPX5 (allows for installation in zone 1 & 2 of bathrooms)

### Finishes

Electroplate / Powder Coat

### Output

100 - 200 Watt

### Materials

Copper tube with brass fittings

### Standards

AS/NZS:3350

## KEY FEATURES

### Replaceable Element

Heating element easily replaced

### Copper Tube

Ensures ultimate thermal conductivity and radiant heat

### Style and Simplicity

Perfects minimalist design and practicality. Generous gaps allow bulky fabrics to be draped over with ease

## VARIATIONS

Electric	Height	Width (A)	Width (B)	Chrome Wattage	P/Coat Wattage
TR2/400	1020mm	400mm	440mm	100 Watts	100 Watts
TR2/500	1020mm	500mm	540mm	100 Watts	150 Watts
TR2/600	1020mm	600mm	640mm	100 Watts	150 Watts
TR2/700	1020mm	700mm	740mm	150 Watts	200 Watts
TR2/800	1020mm	800mm	840mm	150 Watts	200 Watts



PROUDLY AUSTRALIAN  
MADE AND OWNED



**3 YEAR**  
ELECTRIC ELEMENT  
MANUFACTURERS WARRANTY



**10 YEAR**  
CONSTRUCTION & FINISH  
MANUFACTURERS WARRANTY

## TR 3 MODEL Electric or Non-heated

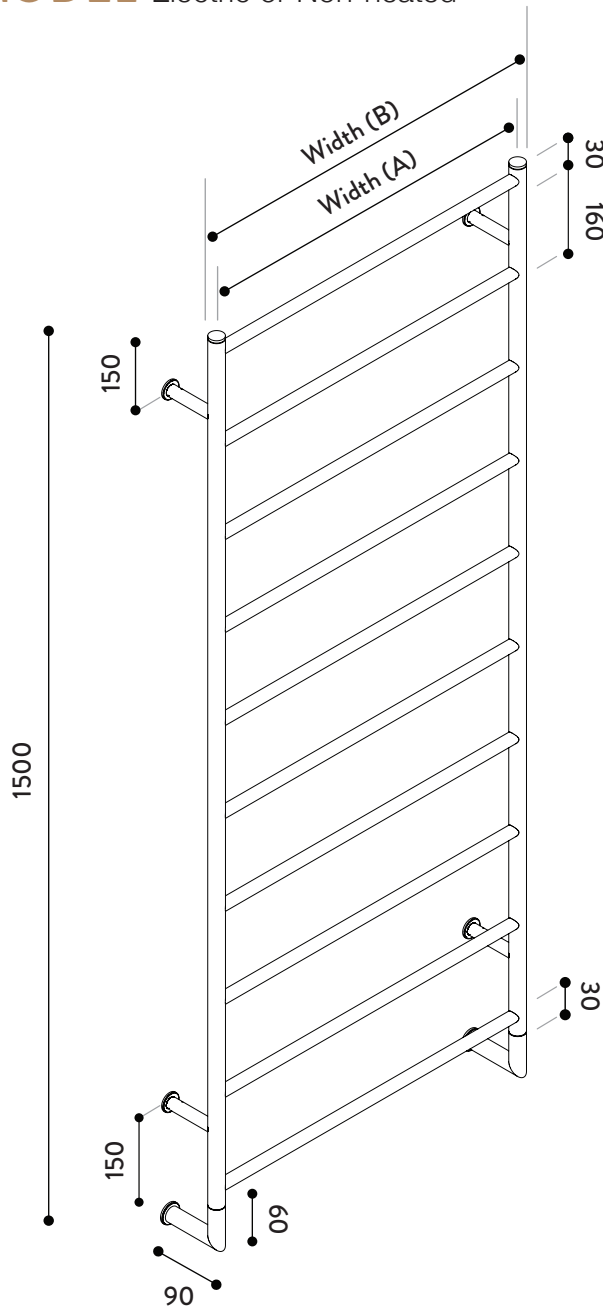

## SPECIFICATIONS

### Height

1500mm + Hardwire

### Width Options

400, 500, 600, 700, 800mm

### Tube Diameter

Vertical 25mm / Horizontal 19mm

### Safety Rating

IPX5 (allows for installation in zone 1 & 2 of bathrooms)

### Finishes

Electroplate / Powder Coat

### Output

150 - 250 Watt

### Materials

Copper tube with brass fittings

### Standards

AS/NZS:3350

## KEY FEATURES

### Replaceable Element

Heating element easily replaced

### Copper Tube

Ensures ultimate thermal conductivity and radiant heat

### Style and Simplicity

Perfects minimalist design and practicality. Generous gaps allow bulky fabrics to be draped over with ease

## VARIATIONS

Electric	Height	Width (A)	Width (B)	Chrome Wattage	P/Coat Wattage
TR3/400	1500mm	400mm	440mm	150 Watts	150 Watts
TR3/500	1500mm	500mm	540mm	150 Watts	200 Watts
TR3/600	1500mm	600mm	640mm	150 Watts	200 Watts
TR3/700	1500mm	700mm	740mm	200 Watts	200 Watts
TR3/800	1500mm	800mm	840mm	200 Watts	250 Watts



PROUDLY AUSTRALIAN  
MADE AND OWNED



**3 YEAR**  
ELECTRIC ELEMENT  
MANUFACTURERS WARRANTY



**10 YEAR**  
CONSTRUCTION & FINISH  
MANUFACTURERS WARRANTY

## INSTALLING BRACKETS

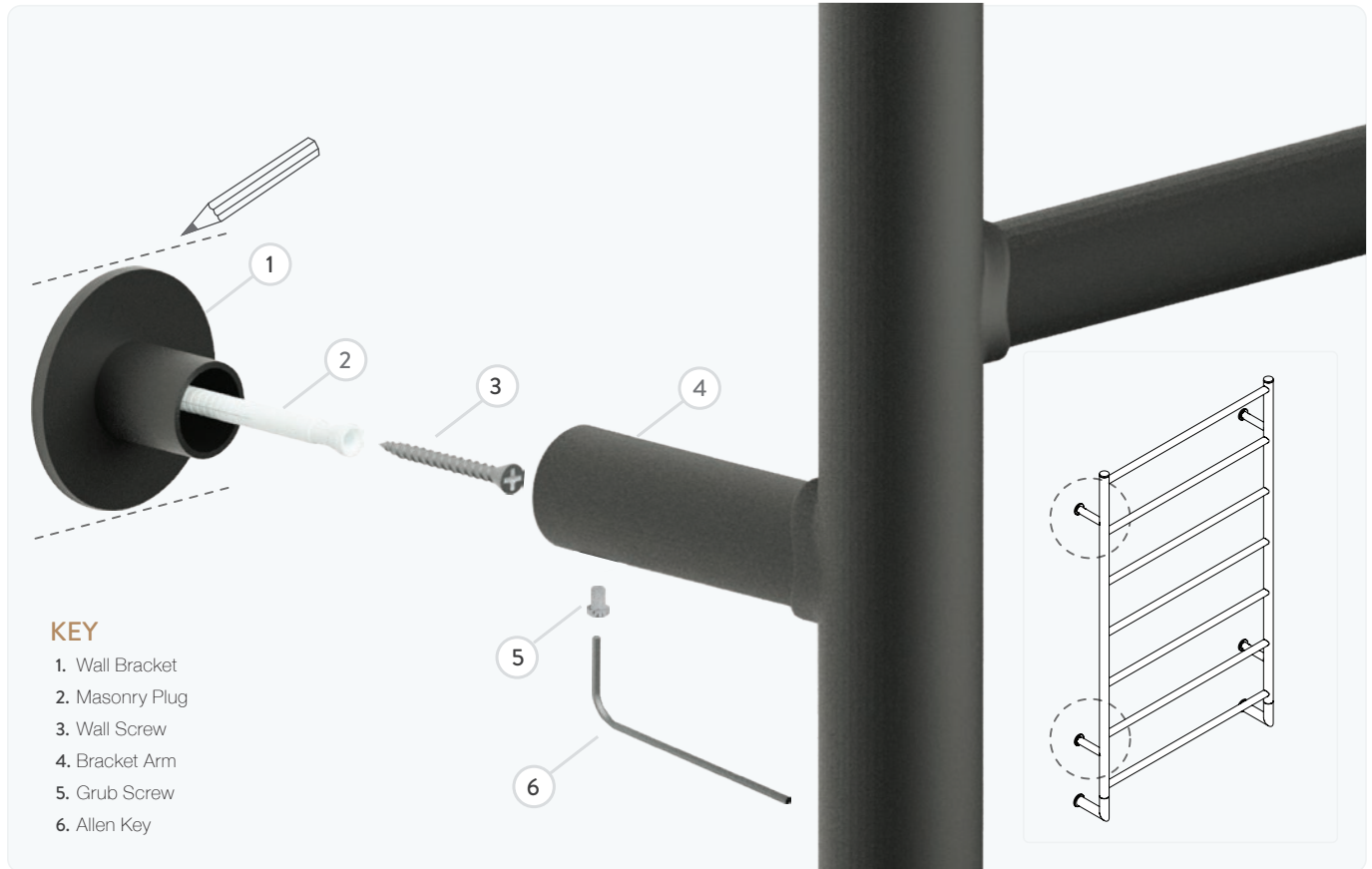

## DIRECTIONS

1. Slide the **Wall Bracket** into the **Bracket Arm** and hold up to the wall in position.
2. With a pencil, outline the **Wall Bracket** in the desired position and remove from the wall.
3. Using a pencil and the **Wall Bracket**, mark the centre screw hole and cross it for accuracy.
4. Drill a hole for the **Wall Screw** and insert nylon plug into tiled wall (if applicable). Installer may choose to use alternative screws to suit the application.
5. Position **Wall Bracket** so that the **Grub Screw** hole faces directly down towards the floor and place **Wall Screw** into the wall.
6. When all of the **Wall Brackets** are in place, slide the **Towel Rail** into position towards the wall, until **Bracket Arm** reaches the **Wall Bracket**.
7. Insert **Grub Screw** through **Bracket Arm** and into **Wall Bracket**.
8. With the **Allen Key** provided, tighten the **Grub Screw** until tight to ensure that towel rail stays in position.

*DO NOT OVERTIGHTEN SCREW - LEAVE SLIGHT ADJUSTMENT OF THE FLANGE (SLACK) TO ENABLE MOVEMENT WHEN THE TOWEL RAIL IS POSITIONED.*



## WARNINGS

**TOWEL RAILS MUST ALWAYS BE INSTALLED WITH THE ELECTRIC ELEMENT POSITIONED AT THE BOTTOM OF THE UNIT FOR CORRECT HEAT TRANSFER**

Hydrotherm take pride in the fact that all rails are individually hand made. Due to this fact some measurements may not be exact. **PLEASE READ INSTRUCTIONS CAREFULLY** and do not force towel rail into bracket if position of wall flange is not accurate.

In order to avoid hazards for young children, this appliance must be installed so that the lowest rung is at least 600mm from the floor.

## WIRING OPTIONS

The Hydrotherm TR - Series Electric Towel rails come pre-filled with water, and with electric elements already fitted (standard on the left unless otherwise specified).

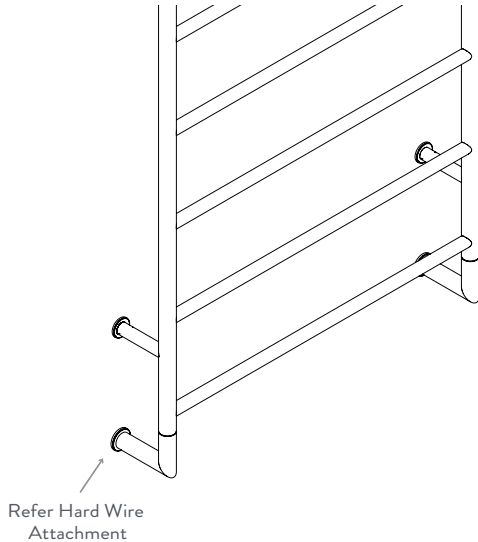

### HARD-WIRED VERSION

The cable may be hard-wired into the wall with an element attachment. Element cable must be positioned at bottom of rail and must be installed by a qualified electrician.

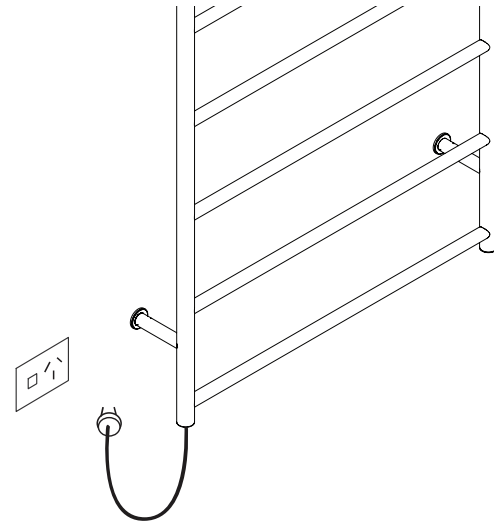

### PLUG IN VERSION

Plug is supplied separately with element cable (1200mm long). Element cable must be positioned at bottom of rail. Cable may be cut and plug attached to required length. Only available upon request

### HARD WIRE ATTACHMENT

Two attachments are provided for both the cable side, and non-cable side so to allow the unit to have a symmetrical appearance (see 'Hard wire version' drawing).

All hard-wired elements have an IP Rating of IP55 (IPX5) for use in wet areas. Hydrotherm also recommend all electric towel rails be connected to a timer for convenience and to prolong the life of the element.

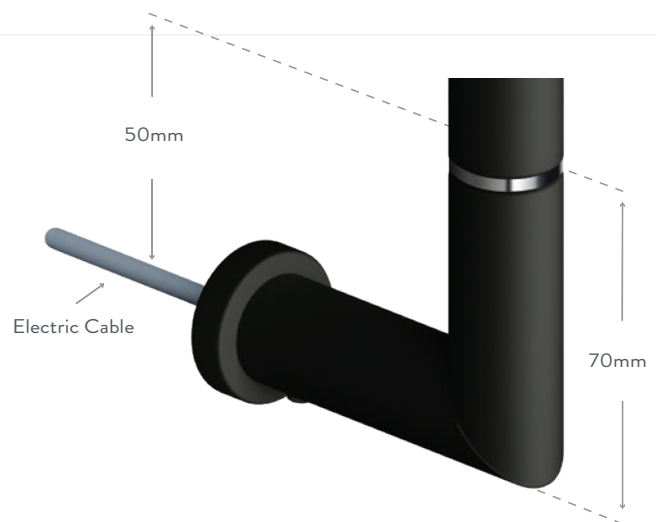

#### **HARD WIRING**

Hydrotherm recommends that all hard-wired heated towel rails be connected to a light switch or timer.

Connecting hard-wired heated towel rails to a light switch or timer will prolong the life of the electric element and reduce energy consumption.

Contact your local hardware store, electrical wholesale outlet, or a qualified electrician to discuss what timers and switches may suit your specific needs best.

All Hydrotherm Elements carry the following approvals.



Elements have a built in thermostat and internal cut out ensuring safety and energy efficiency. All Hydrotherm electric elements can be supplied as 240v or 110v. All electric elements are replaceable and can be easily changed over.

## CHANGING ELEMENTS

To change an element from one side to the other, or to replace an old element is a very simple process.

### THERE ARE FOUR BASIC STEPS

1. Remove towel rail from brackets (if already installed), and slip off Hard Wire Attachments.
2. Turn the towel rail upside down and with a spanner loosen the hex nut of the electric element. When the element is loose, unscrew it by hand. If you are changing the element from left to right or vice versa, the internal plug on the opposite side must also be removed and swapped over with the element.
3. Swap the element and screw in place. Reattach hard wire pieces.
4. Turn the towel rail the right way up, position back into brackets and refit grub screws to secure.

Please note:

Hydrotherm advise that the unit be removed from the wall and turned upside down to ensure that water does not spill. Ensure element always remains at bottom of towel rail.

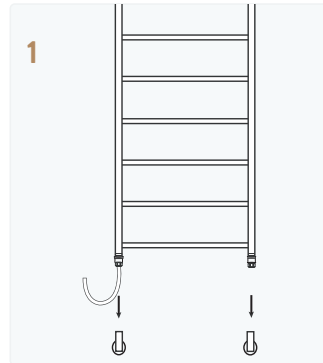

Element on left side

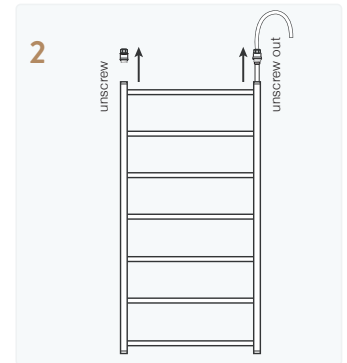

Turn rail upside down

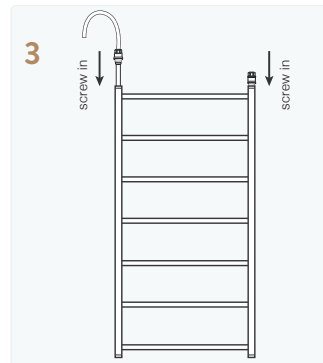

Swap Element over

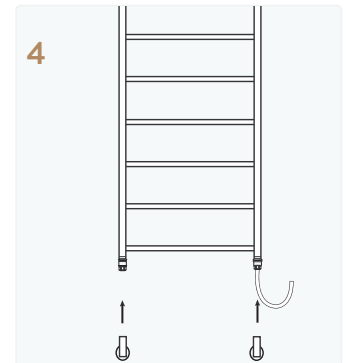

Element on right side



## CARING FOR YOUR TOWEL RAIL

Guidelines for the Cleaning and Care of your Towel Rail



### INSTALLATION

Damage to tapware and bathroom accessory surfaces is often caused by the installation/removal process. So it is highly recommended that you thoroughly inspect your products out of the box, before they are installed. Ensure your tradespeople take special care when handling and installing, using clean hands or gloves and washing off any plumbing product.



**Under NO circumstances should a silicone sealant be used when fitting or handling. If such sealants come into contact with the product, the sealant residue MUST be thoroughly washed immediately.**

Once installed, the fittings need protection until the job is finished. Cover the surfaces to avoid splatters from paint or commercial cleaning products.

### CARE AND MAINTENANCE

Please follow these cleaning and care instructions to best maintain the finish of the product you have selected.

The ideal care for all fittings is to dry them with a soft cloth after each use, which will prevent mineral deposits.

Fittings should be regularly cleaned with warm water or a mild pH-neutral liquid soap and water and polished with a clean soft cloth.

A Microfiber cloth is gentle and effective for cleaning without scratching and needs only to be dampened to clean the product. Residue left by personal hygiene products such as liquid soap, tooth paste, shampoo and shower gel can cause damage. Always rinse these off the fittings with clean water immediately after use.



**Under no circumstances should harsh cleaning agents containing acidic, caustic or abrasive components or citrus, bleach or alcohol based substances be used to clean these fittings and should not be allowed to remain on metal finishes.**

**Avoid dripping or over spraying such cleaning agents by covering the fixtures with a cloth or towel, metal finishes splashed with these products should be immediately rinsed with clean water and dried. Do not use abrasive cloths, scouring pads, scrub sponges, steel wool etc.**

### HOMEOWNERS GUIDE TO PLATED FINISHES

**NOTE: Scouring, steel wool, Scotchbrite, powder or abrasive cleaners should not be used on any plated finishes. This does not apply to uncoated bare brass.**



**CHROME:** The most durable of the electroplated finishes, cleaning as per the guidelines above.



**BLACK CHROME:** High Gloss electroplated finish, not as resistant to scratching or scuffing as standard chrome. Cleaning and care as per guidelines above.



**MATTE BLACK CHROME:** Low Gloss electroplated finish with a microscopically rough surface which gives the matte appearance. Cleaning as per guidelines above. Avoid the use of waxes or polishes as they will fill the surface and give the part a polished look.



**NICKEL AND BRUSHED NICKEL:** Electroplated finishes known as "living finishes" which over time will develop an individual patina, giving it a distinctive classical look, however nickel finishes do require regular care. It is important to clean nickel finishes after use to prevent tarnishing. Water should be dried off and prevented from building up and forming hard water spots (which if left can be difficult to remove). It is highly recommended to clean your tapware regularly as per the guidelines above.



**GOLD:** Products should be only cleaned with a microfiber cloth, warm water and pH neutral liquid soap as per guidelines above.



**UNCOATED BARE BRASS:** As a living finish, un-lacquered brass will mature over time to develop a patina and unique character, typical of old brassware. Always have clean hands when handling brassware. All uncoated bare brass can be cleaned with mild soap and water which will not alter the aging process. Polished uncoated bare brass that has been buffed to a shiny finish; over time the polished brass will garner a patina and the surface lose some of its brightness. Brass fittings can be cleaned routinely with mild soap and water which will not alter the patina development. If desired the shine can be restored with a very mild abrasive cleaner like Brasso.



**SATIN UNCOATED BARE BRASS:** Has a brushed surface which reduces the gleam on the surface. A brushed finish is more susceptible to staining or marks from chemicals or acids as the surface has small 'scratches' which pick up the stain. Therefore, establish a simple routine of rinsing off the tap with warm water and drying it, if it is splattered with cooking acids or chemicals such as toothpaste. If uneven staining occurs, this finish can be refurbished when dry with a gentle abrasive cloth – such as a non-scouring cleaning pad (eg. Scotchbrite). If the surface is polished with a metal polish this will reduce the brushed effect.



**LACQUERED FINISHES:** This is an acrylic lacquer topcoat applied to provide additional protection to soft or low corrosion resistance coatings such as rose gold. Simply wiping and drying with a soft cloth will maintain the finish. Never use abrasives of any nature as these will scratch and wear the coating. Follow guidelines as set out above.

**ANTIQUÉ FINISHES:** Refer to specific guidelines.

## THE HYDROTHERM WARRANTY

Our warranty covers the repair or (At Hydrotherm's discretion) the replacement of any items flawed through impaired workmanship or materials. Hydrotherm Towel Rails possess a 10 year guarantee on the integrity of their construction and finish. The internal heating element carries a 3 year warranty only.

Warranty period commences from date of purchase. Please ensure proof of purchase information is preserved. All warranty issues are to be initiated through original point of purchase, so that an official service call can be lodged through the appropriate channels. From here our After Sales Service Team will act accordingly.

### IMPORTANT INFORMATION

All Hydrotherm Heated Towel Rails are supplied with water, unless otherwise specified. This unit is not designed to be used as a ladder. No responsibility will be taken by Hydrotherm Australia Pty. Ltd for incorrect installation. All warranty will be void if instructions are not followed.

### ELECTRIC MODEL

Electric connection must be installed by a qualified electrician. All Hydrotherm Towel Rails carry an IPX5 rating for use in wet areas. If the electrical cable is damaged, the entire element must be replaced. When connecting, element must be positioned at the bottom of the towel rail. If installed incorrectly, Towel rail will not operate effectively and may cause damage to the element.

### WARRANTY WILL BE VOIDED FOR THE FOLLOWING REASONS

- Failure to provide adequate proof of purchase or similar documentation.
- Hard wired towel rails not installed by a licensed electrician.
- Towel Rails not installed in accordance with State and or National standards.
- Failure to install towel rail in accordance with manufacturers instructions.
- Product used for incorrect applications.
- Service, repairs or alterations undertaken without manufacturers written approval.
- Damage to finish which arise from installation or post installation.
- Failure to adhere to manufacturers care and cleaning directions.



**3 YEAR**  
ELECTRIC ELEMENT  
MANUFACTURERS WARRANTY



**10 YEAR**  
CONSTRUCTION & FINISH  
MANUFACTURERS WARRANTY

### 100% AUSTRALIAN MADE AND OWNED

Manufactured by Hydrotherm Australia,  
96 Commercial Drive Thomastown Victoria 3074

Tel: +61 3 9464 4622  
Fax: +61 3 9464 4722

[www.hydrotherm.com.au](http://www.hydrotherm.com.au)  
[sales@hydrotherm.com.au](mailto:sales@hydrotherm.com.au)



**PROUDLY AUSTRALIAN  
MADE AND OWNED**