

Assembly Instructions

Components List

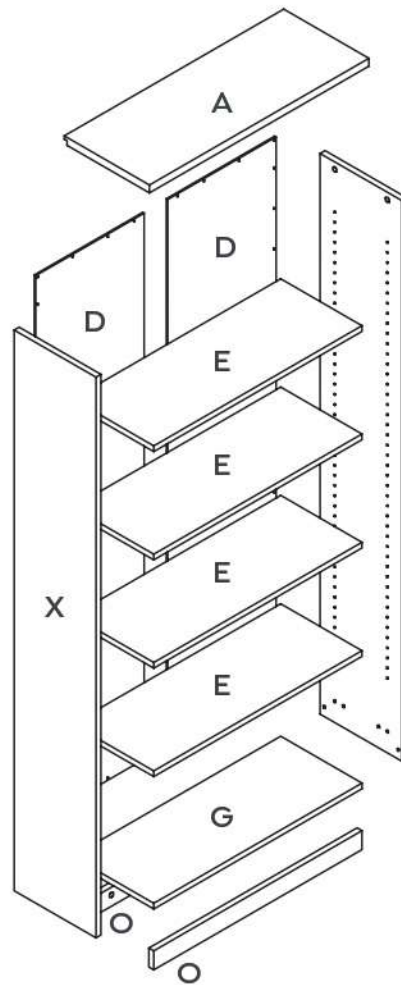

Pre-installed parts:

c2



16 - Cam
Cover

p1



16 - Threaded
Dowel Pin

s1



42 - 3.5x14
Screw

b1



1 - Backing
Strip

c5



Cam

WARNING



Children have died from furniture tipover.

- Always secure this furniture with an anchor device.
- Never allow children to stand, climb or hang on drawers, doors or shelves.
- Never open more than one drawer at a time.
- Place heavy items down low.

STEP 1:

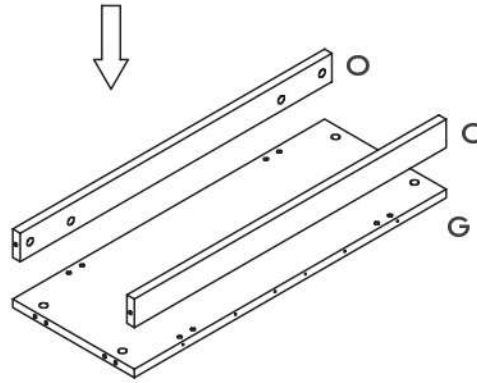

Preparation for Panels O and G.

1. Connect Cam bolts and dowels on panel O to the holes on panel G and tighten in a clockwise direction as illustrated above.

STEP 2:

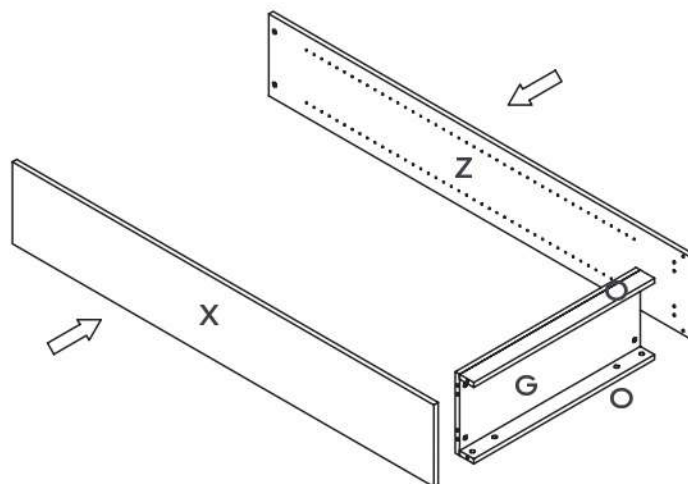

Preparation for Panels X and Z.

1. Connect Cam bolts and dowels on panel O and G to the holes on panel X and Z and tighten in a clockwise direction as illustrated above.

STEP 3:

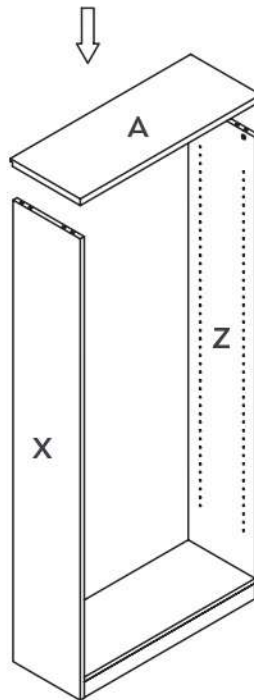

Preparation for Panels A.

1. Connect Cam bolts and dowels on panel X and Z to the holes on panel A and tighten in a clockwise direction as illustrated above.

STEP 4:

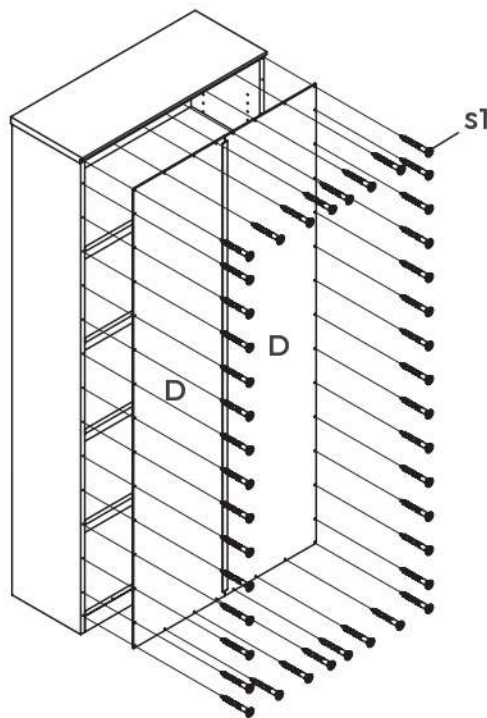

s1



3.5x14 Screw

Bookcase back panel D assembly.

1. Connect back panel D and panel X, Z, G, A with screw (s1) as illustrated above.

STEP 5:

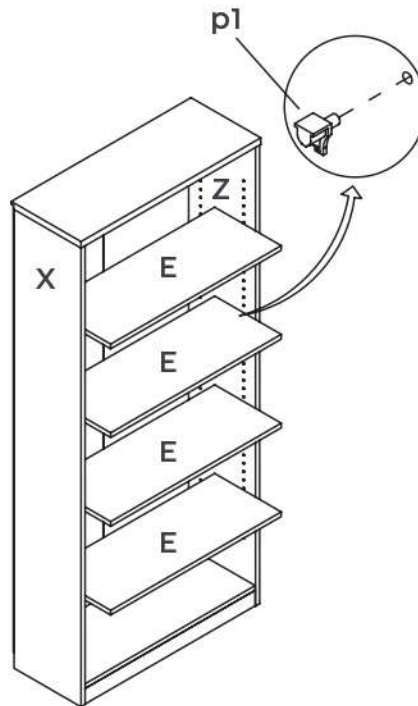

Moveable shelf E assembly.

1. Insert threaded dowel pins (p1) into panels X and Z as illustrated above.
2. Put the two panels E on the top of threaded dowel pins (p1) as illustrated above.

Complete:

WARNING

Children have died from furniture tipover.

- ALWAYS secure this furniture with an anchor device.
- NEVER allow children to stand, climb or hang on drawers, doors, or shelves.
- NEVER open more than one drawer at a time.
- Place heavy items down low.

NEVER place a TV on this furniture

This is a permanent label. Do not remove!
Ask staff for more information or visit <https://www.productsafety.gov.au>

AUSTRALIAN FURNITURE ASSOCIATION
 Australian Furniture Industry Regulatory Council

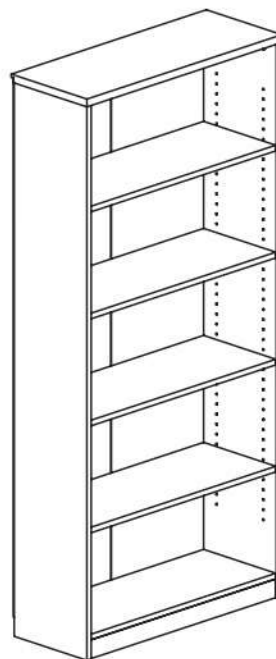

Toppling furniture mandatory standard:

It is mandatory to affix the supplied permanent Warning Label to any toppling furniture covered by the Standard. The label must be placed in a visible location, ensuring it can be easily seen when the furniture is empty.