

ASSEMBLY INSTRUCTION

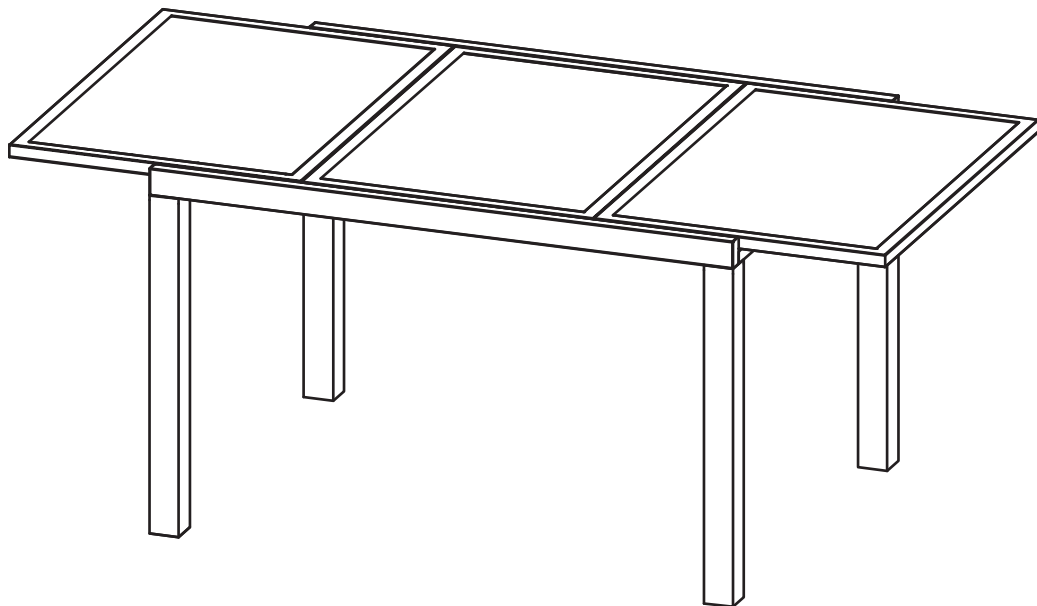

OTF-547A
OTF-548A
OTF-549A
OTF-553A

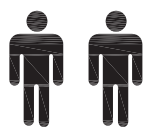

2 PERS.

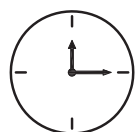

30 MIN

Important Tips and Maintenance



1. Keep children and animals away from working area as smaller parts may cause choking if swallowed



2. Never place liquids or anything damp upon furniture as it will mark, Ensure a coaster or running is beneath.



3. New use ammonia based cleaning products as it will damage the finish.

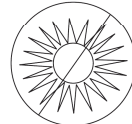

4. To avoid fading, keep furniture out of direct sunlight.



5. Use a soft or damp cloth (dry cloth) when wiping or cleaning surface.

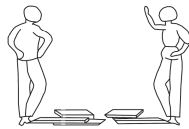

6. Two person are required



7. Lay a soft matt down to protect the furniture pieces before and during assembly.

Assembling flat pack furniture could be slightly stressful. We recommend treating yourself to a cup of tea and taking a short rest after a few steps have been completed. Few tips to the assembling:

*Get ready

Space / Protect / Light / Safety

*Pre-battle prep

It is not tackling Mt Everest or running an ultra marathon but needs a certain amount of calm.

*Sort it out

Divide up the pieces of furniture before you start into relevant piles. Sorting and counting the screws.

*Read up

The instructions are just pictures with arrows and numbers, but familiarising yourself with the flow of the work stops you from making mistakes.

*On your marks

Remember, slow and steady wins the race

Feel free to contact your seller with any questions or comments



DO NOT USE any type of power tool when assembling the furniture.
It is easy to insert screws too far and cause damage.

A

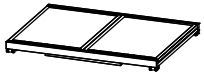

1pc

B

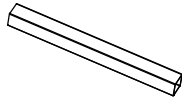

4pcs

C

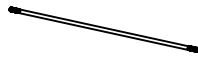

4pcs

D



4pcs

E



4pcs

F



8pcs

G

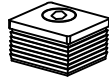

4pcs

H

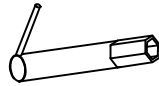

1pc

①

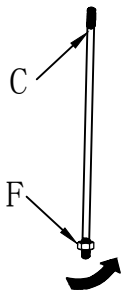

Please make sure to fasten nuts to the one side of the rods (Part C) first.

②

Manually screw the rod in and all the way to the end, then tighten the nut with tool H

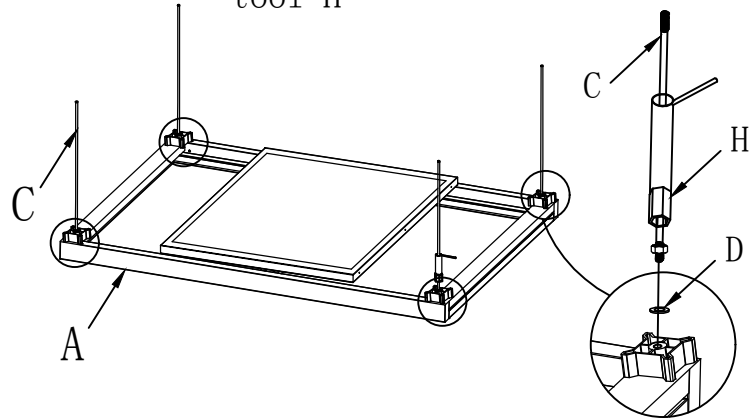

Attention: Lay a soft mat/protector down to avoid the scratch/damage to the table top

③

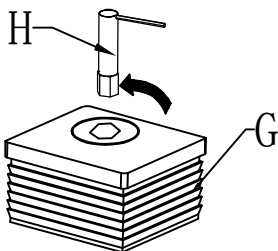

④

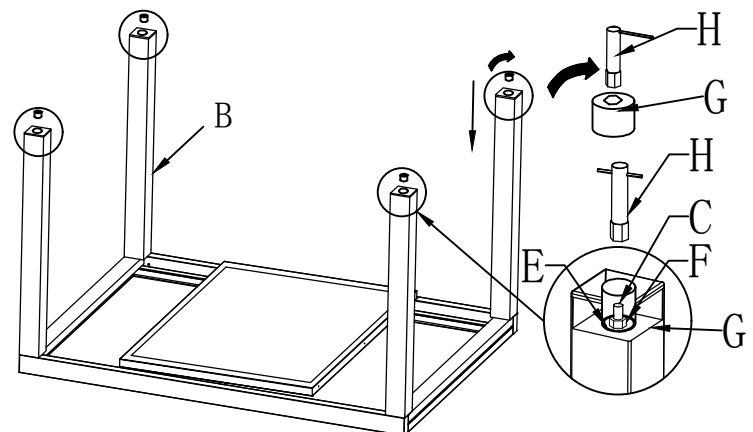

⑤

Warning : Do unlocking by pressing the button under the tabletop on both sides . Make sure it is in the unlock position before extending .

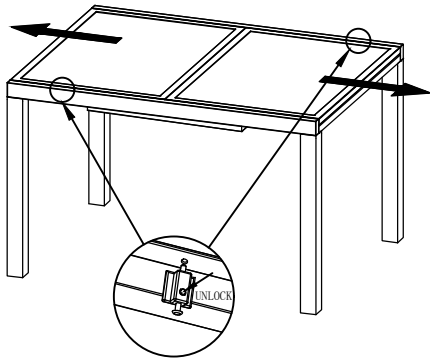

⑥

Please pay attention to the fixing position . Make sure the table top is fully extended .

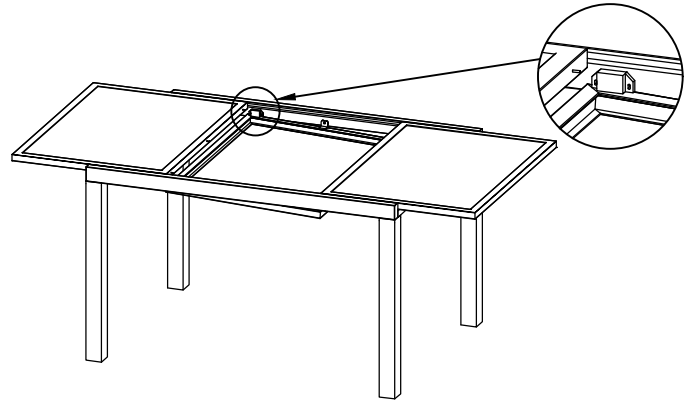

⑦

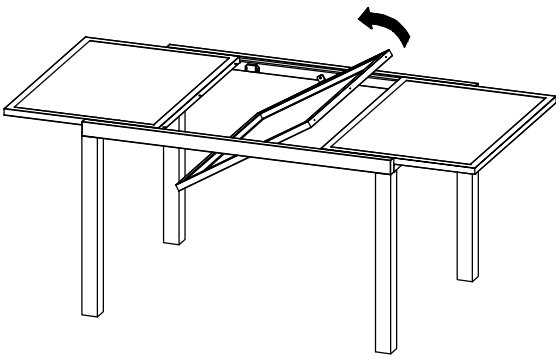

⑧

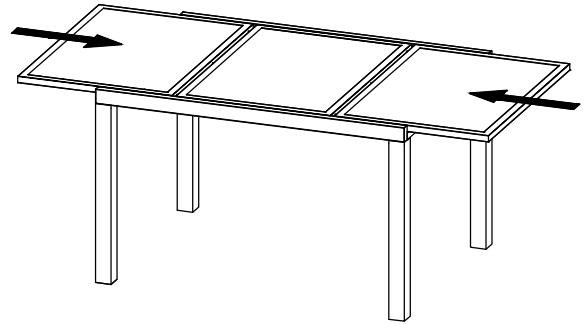

⑨

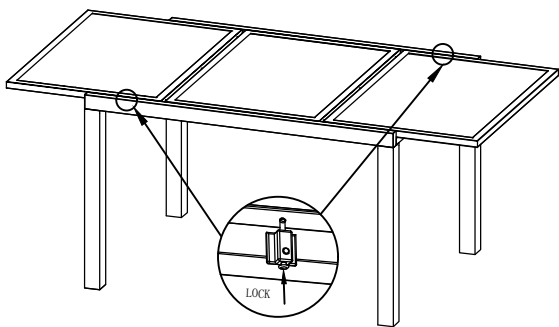

Do "locking" by pushing the buttons upward under the tabletop on both sides . Dragging may cause the table top failure if not fully locked .

⑩

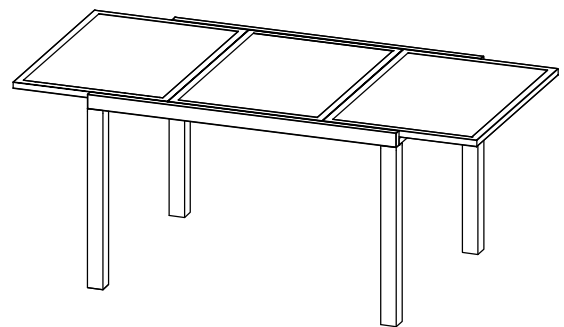

Adjust the feet height (refer to Step 3) to make the table balance if required .

Great Job, You're done!