

## TIPS

- 1 Please review all parts and hardware before disposing of any packaging.
- 2 Check to be sure that all parts and hardware are complete before you start assembly.
- 3 Before beginning assembly, separate each type of screw.
- 4 **Using a screw that is too long will cause damage.**
- 5 Carefully study the screw diagrams below.
- 6 You may receive extra hardware with your unit.
- 7 Place all parts on a clean and smooth surface to avoid the parts from being scratched.
- 8 Keep the product away from heat and humidity.
- 9 Light blue stains and natural wood knots on the product are not considered defects.
- 10 Before start assembly, please categorize the hardware.

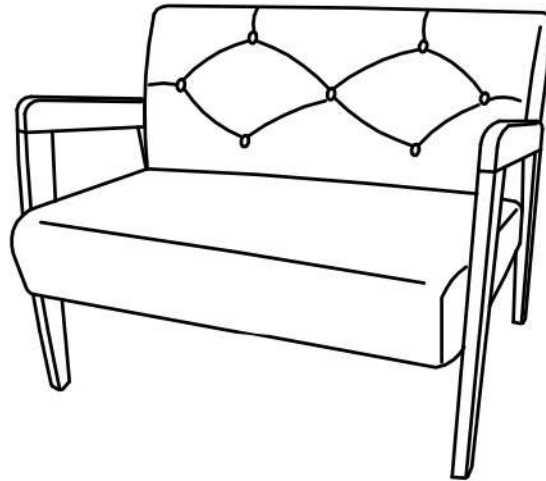

PART LIST

**A** Seat Cushion  
1Pc

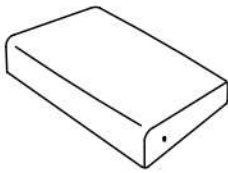

**B** Backrest  
1Pc

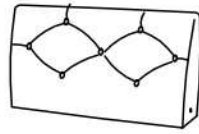

**C** Leg Frame (Left)  
1Pc



**D** Leg Frame (Right)  
1Pc



HARDWARE LIST \*Before start assembly, please categorize the hardware.

**E** JCBB Screw M8 x 45mm  
4Pcs



**F** JCBC Screw M6 x 45mm  
6Pcs

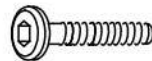

**G** Spring Washer  
5/16"  
4Pcs



**H** Spring Washer  
M6 (S)  
6Pcs



**I** Flat Washer  
5/16" x 22mm  
4Pcs



**J** Flat Washer  
M6 x 19mm  
6Pcs



**K** Allen Key M5  
1Pc



**L** Allen Key M4  
1Pc



ASSEMBLY INSTRUCTIONS

1 STEP 1

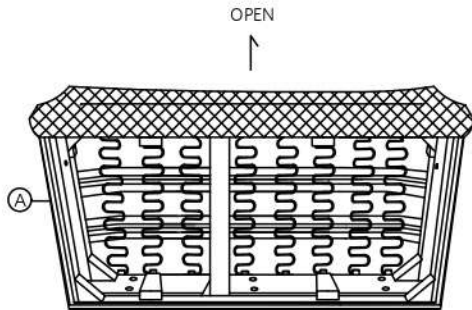

2 STEP 2

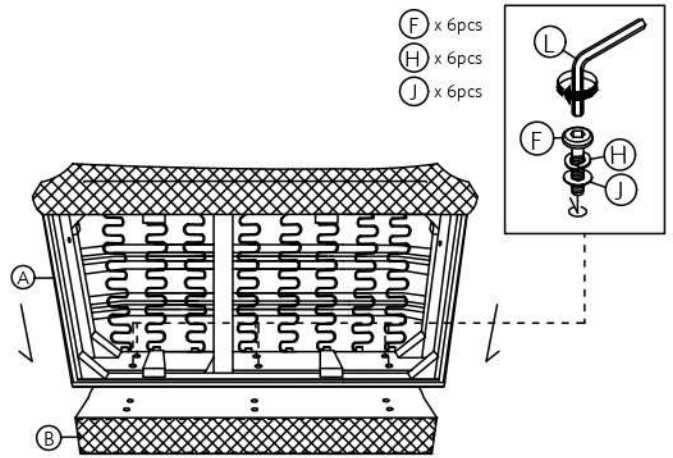

3 STEP 3

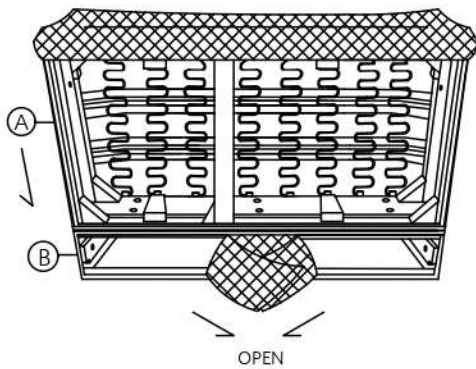

4 STEP 4

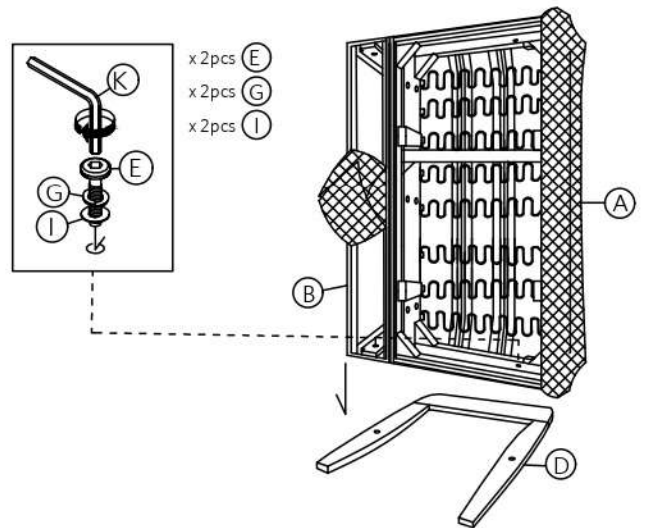

5 STEP 5

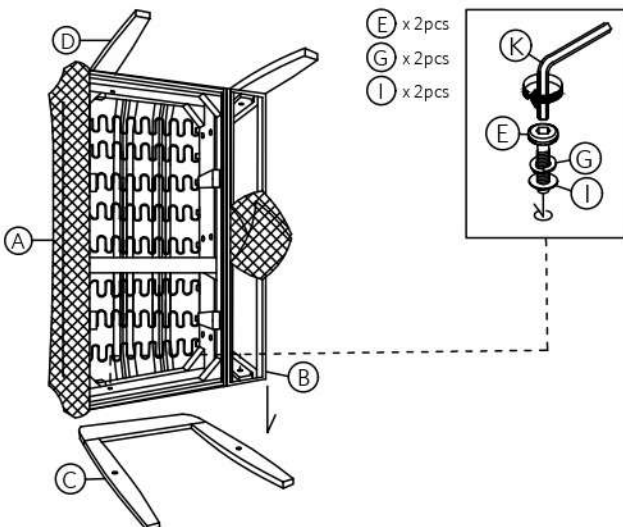

6 STEP 6

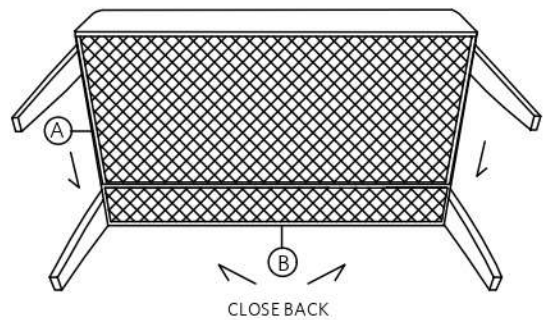

ASSEMBLY INSTRUCTIONS

7 STEP 7

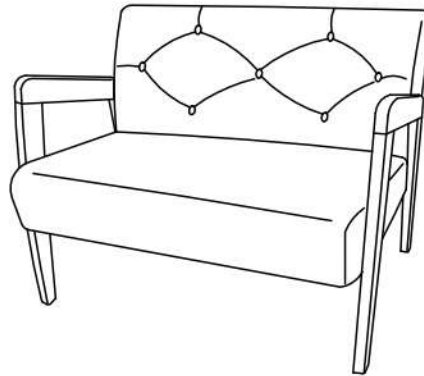

OPTIONAL

8 STEP 8

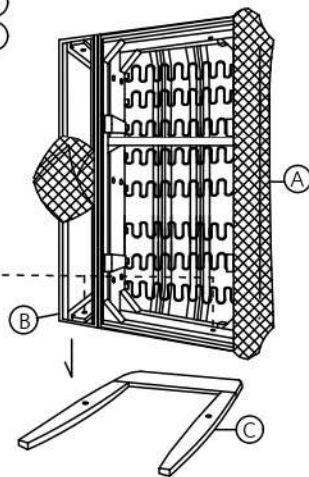
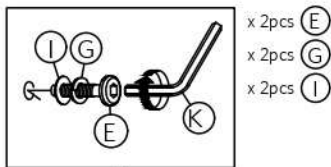

9 STEP 9

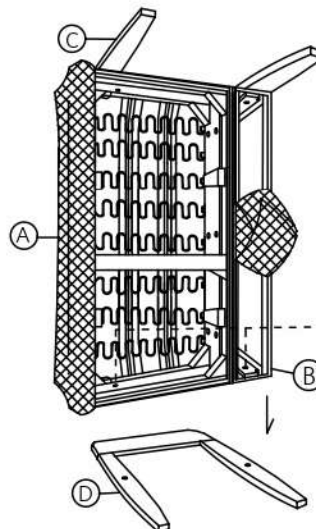
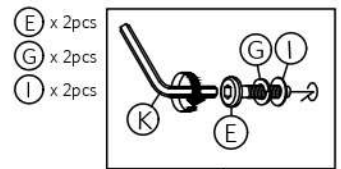

10 STEP 10

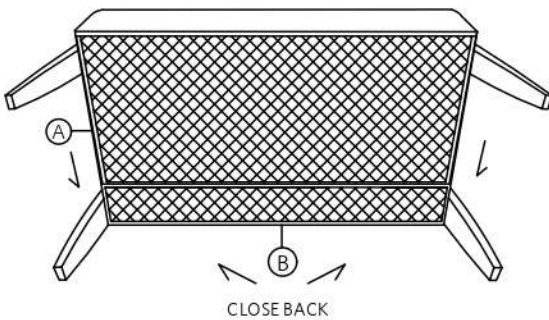

11 STEP 11

