

# Assembly Instruction

**BED FRAME**  
**IHD-BED06-S**

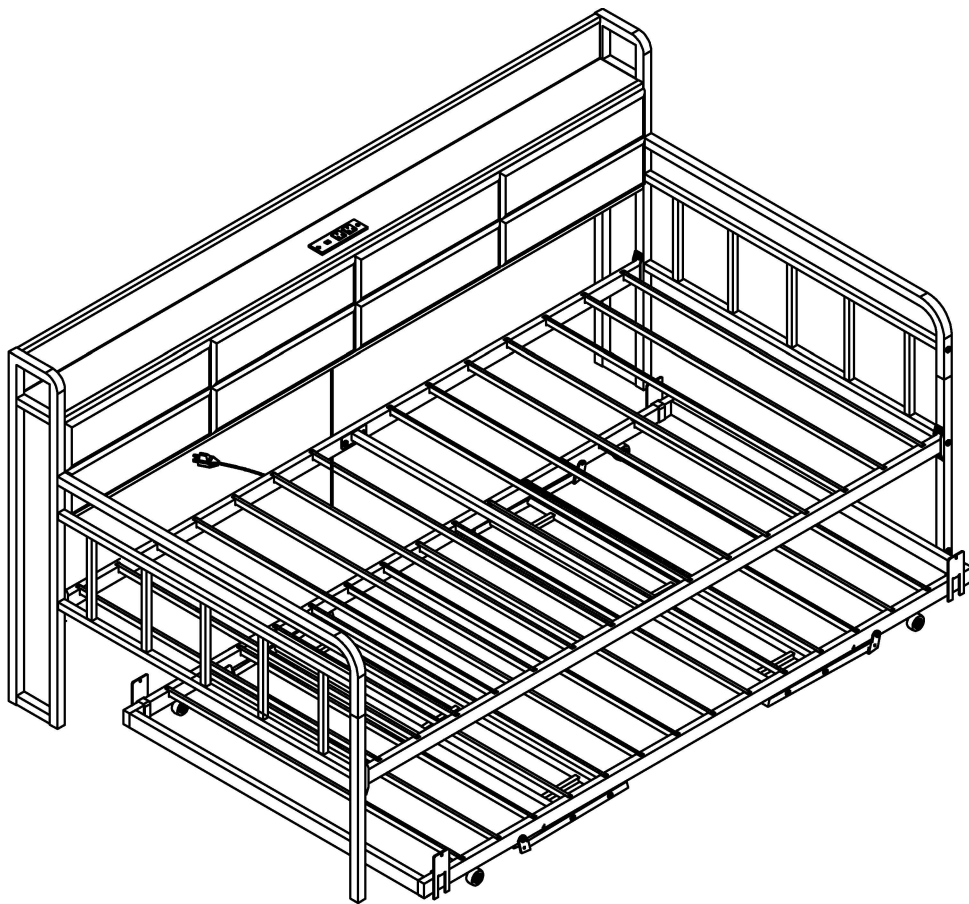

---

## Customer Service Before Return

If part is missing or damaged, or you need help with assembly, please do not hesitate to contact us.

**SELLER CONTACT INFORMATION:**  
**[contacts@ihomdec.com](mailto:contacts@ihomdec.com)**

## Dear Customer:

Thanks a lot for choosing our product. Please read each step carefully. It's very important that each step of the instructions is performed in the correct order. If these steps are not followed in sequence, assembly difficulties will occur. Please retain these instructions for future reference.

-Please read the instruction sheets completely before assembly. Remove all parts from the carton and ensure all components are included before assembly.

-Assemble the bed on a protected surface to avoid scratching the components of the bed. Be careful not to cross-thread screws. Please use a piece of the cardboard packaging to protect your floor and product. Two people are recommended for assembly!



Pls make sure all the accessories are complete!

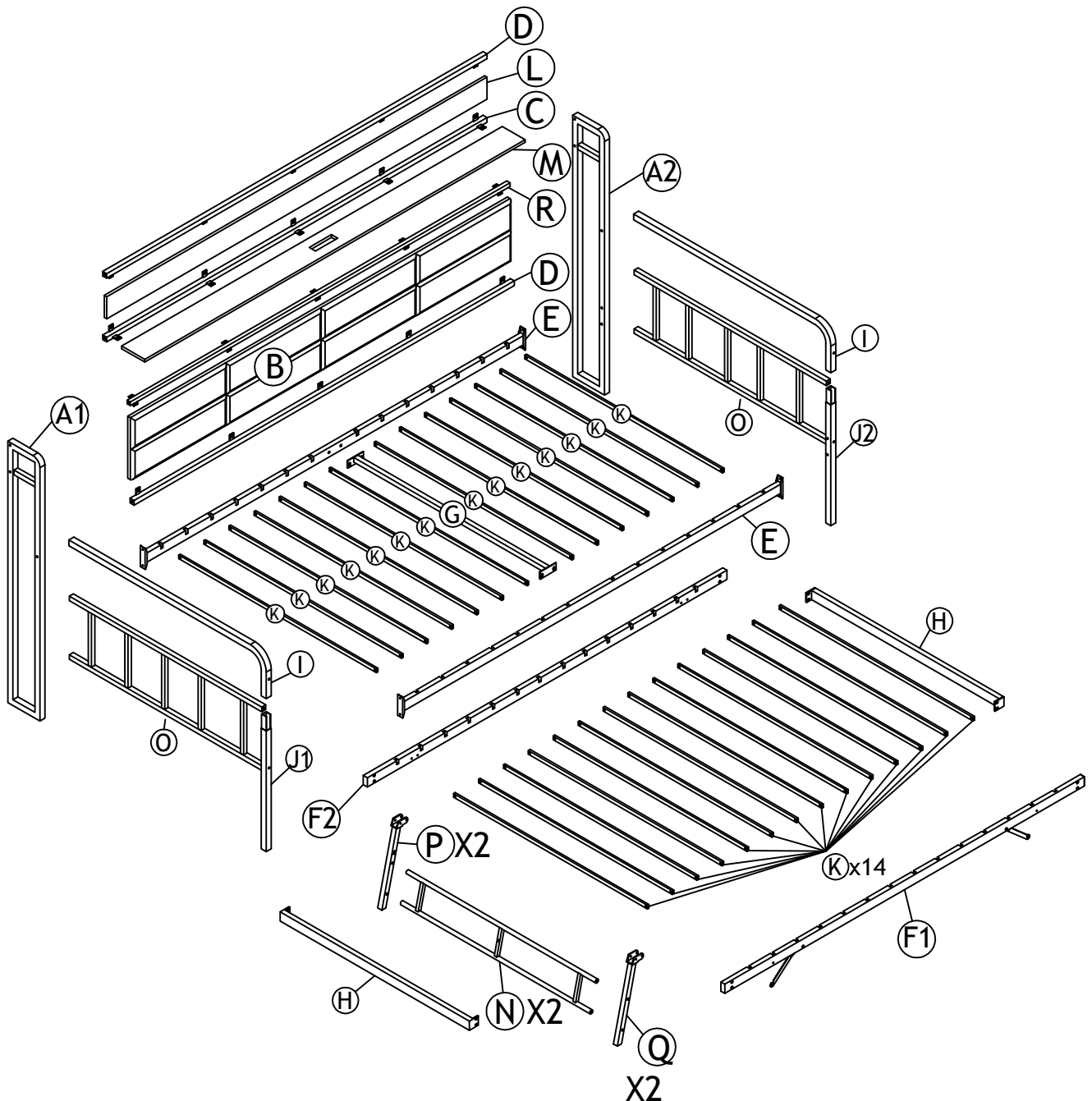

# Parts Identification 1/2

Not actual size

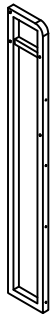

(A1)

Qty:1



(A2)

Qty:1

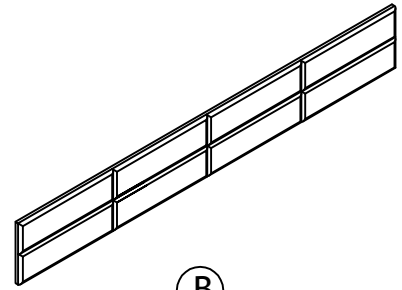

(B)

Qty:1

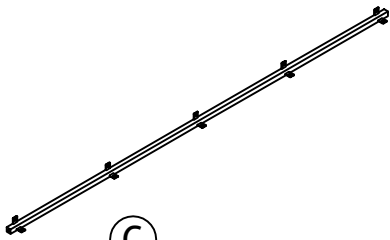

(C)

Qty:1

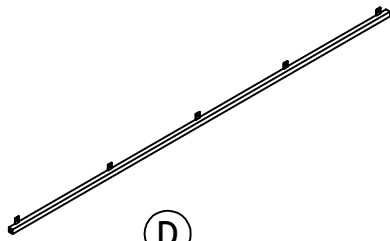

(D)

Qty:2

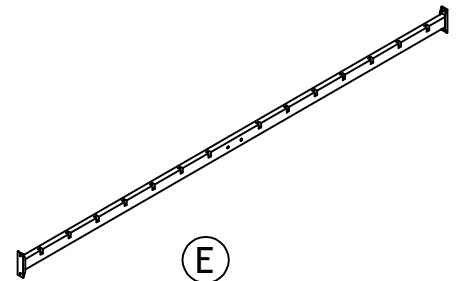

(E)

Qty:2

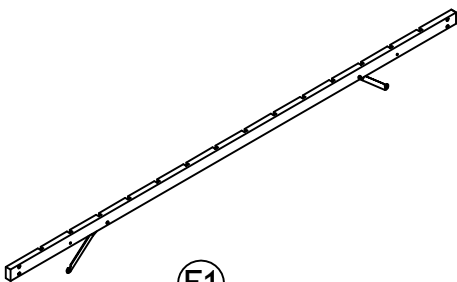

(F1)

Qty:1

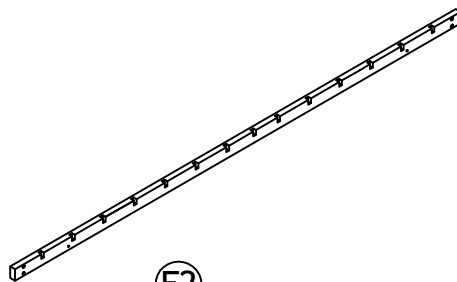

(F2)

Qty:1

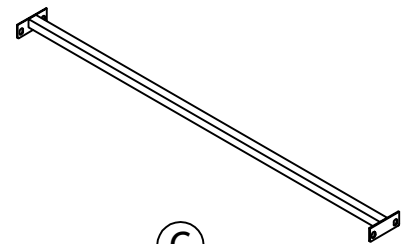

(G)

Qty:1

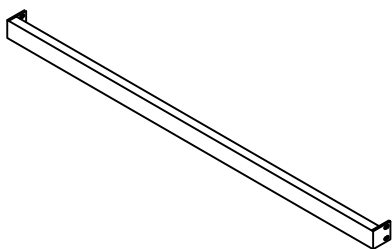

(H)

Qty:2

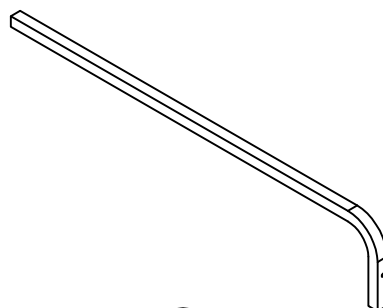

(I)

Qty:2



(J1)

Qty:1

# Parts Identification 2/2

Not actual size



(J2)

Qty:1



(K)

Qty:28

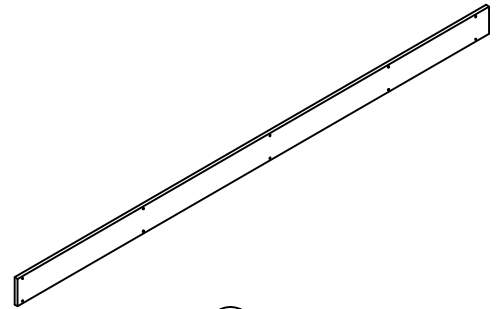

(L)

Qty:1

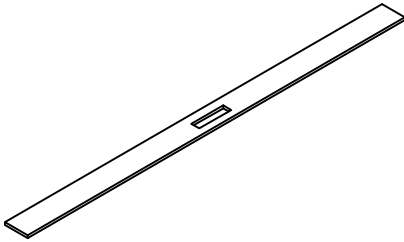

(M)

Qty:1

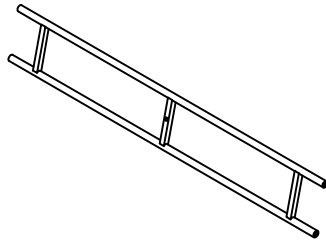

(N)

Qty:2

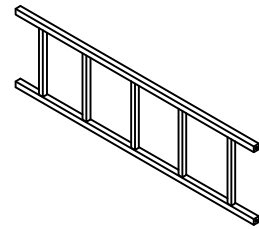

(O)

Qty:2

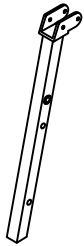

(P)

Qty:2

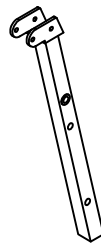

(Q)

Qty:2

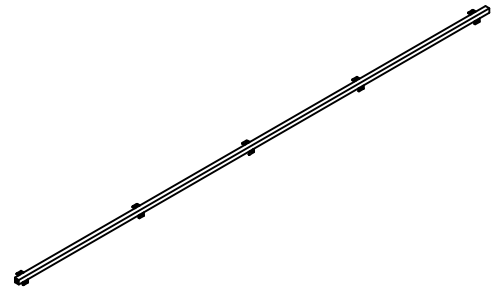

(R)

Qty:1

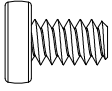

Ø1/4" x 11mm

1	x 20
---	------

BOLT  
spare: 2

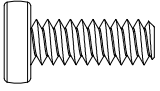

Ø1/4" x 16mm

2	x 26
---	------

BOLT  
spare: 2

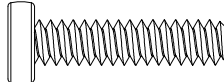

Ø1/4" x 35mm

3	x 4
---	-----

BOLT  
spare: 1

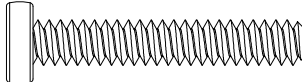

Ø1/4" x 50mm

4	x 26
---	------

BOLT  
spare: 2



Ø3 x 12mm

5	x 2
---	-----

SOCKET

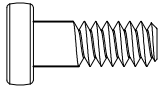

Ø1/4" x 16mm

6	x 2
---	-----

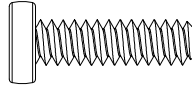

Ø1/4" x 20mm

7	x 8
---	-----

BOLT  
spare: 1



11

8	x 1
---	-----

SOCKET

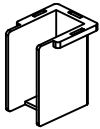

9	x 56
---	------

PLASTIC CAP

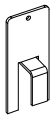

10	x 4
----	-----

CASTER



11	x 2
----	-----

CASTER



11

12	x 1
----	-----

SPANNER

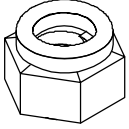

M4

13	x 4
----	-----

SCREW



14	x 2
----	-----

CASTER



15	x 2
----	-----

CASTER



16	x 1
----	-----

SPANNER

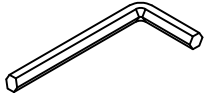

M4

17	x 1
----	-----

ALLEN KEY

# STEP 1

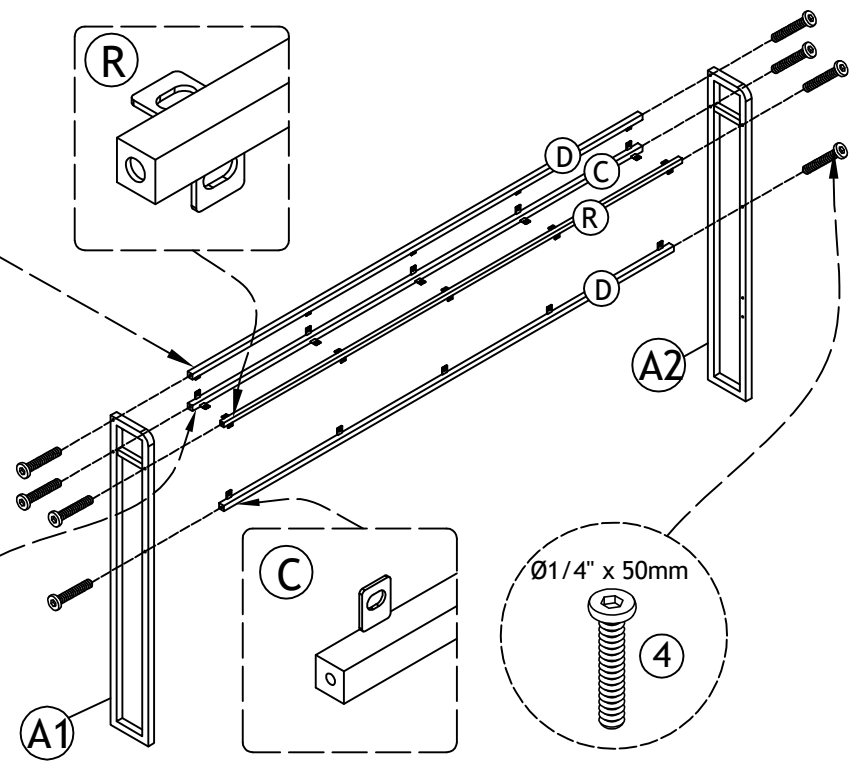
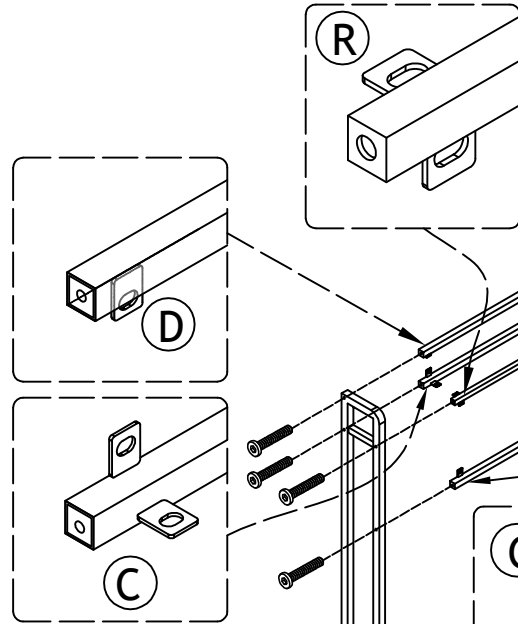
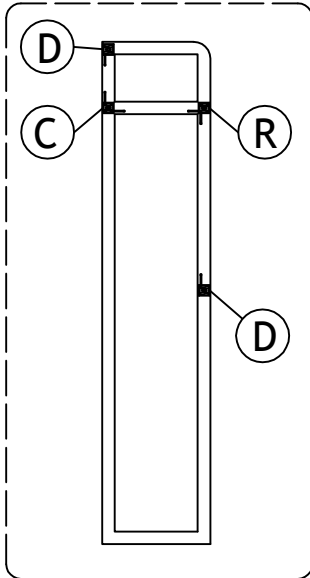
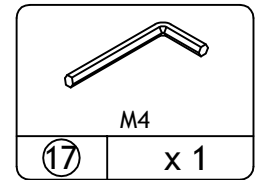
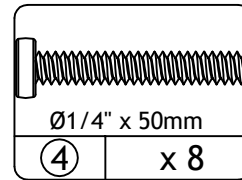
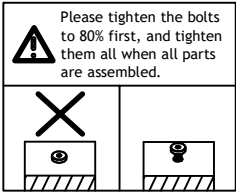

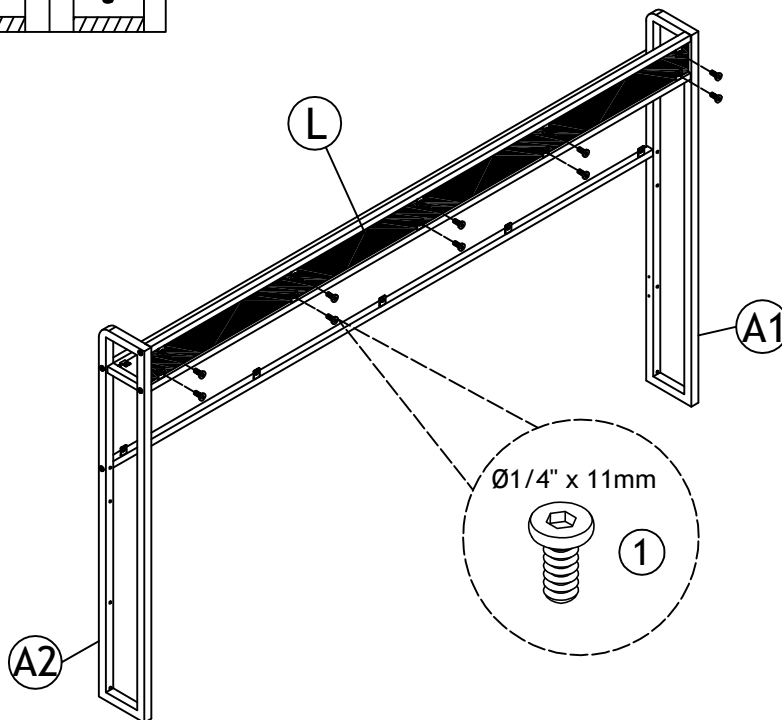
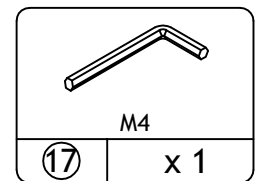
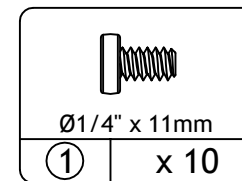
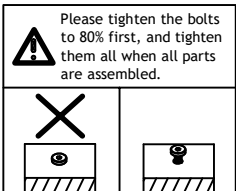

Please pay attention to the direction of the metal bolt plate.

# STEP 2



# STEP 3

 Please tighten the bolts to 80% first, and tighten them all when all parts are assembled.

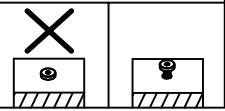

Ø1/4" x 11mm

1	x 10
---	------



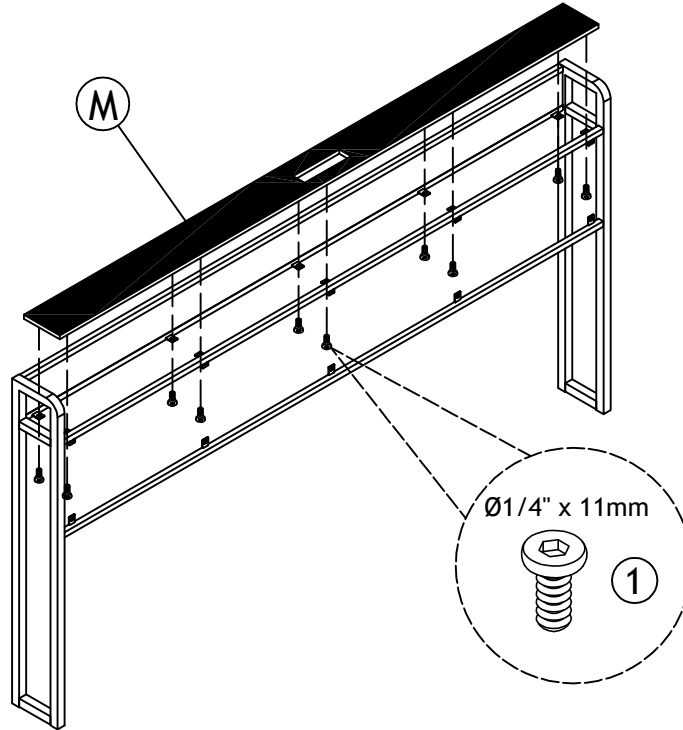

M4

17	x 1
----	-----



# STEP 4

 Please tighten the bolts to 80% first, and tighten them all when all parts are assembled.

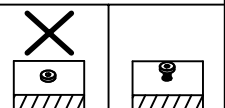

Ø1/4" x 16mm

2	x 10
---	------



M4

17	x 1
----	-----

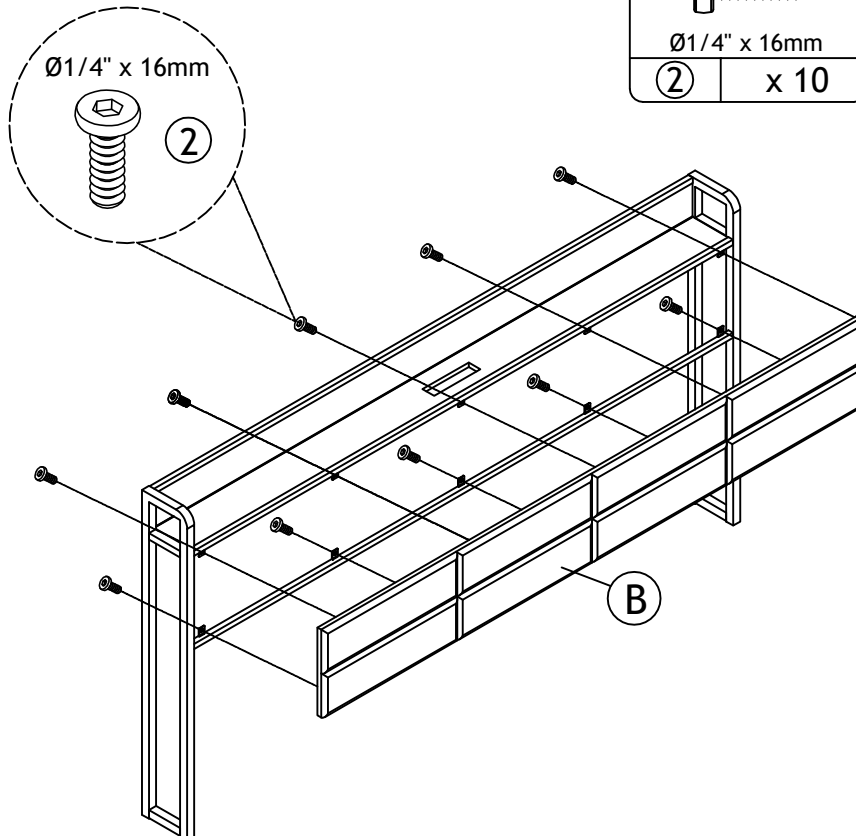

# STEP 5

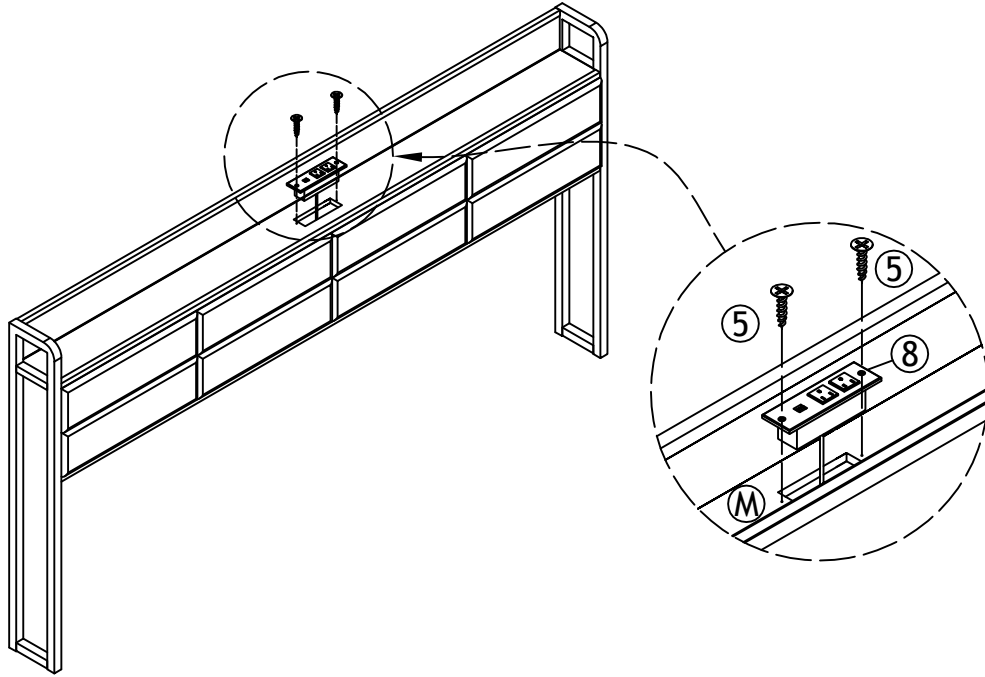
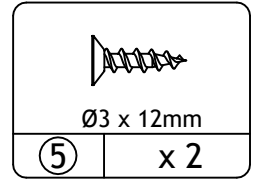
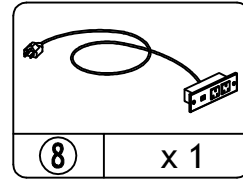
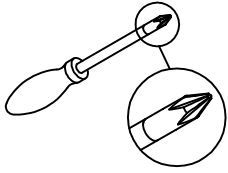

# STEP 6

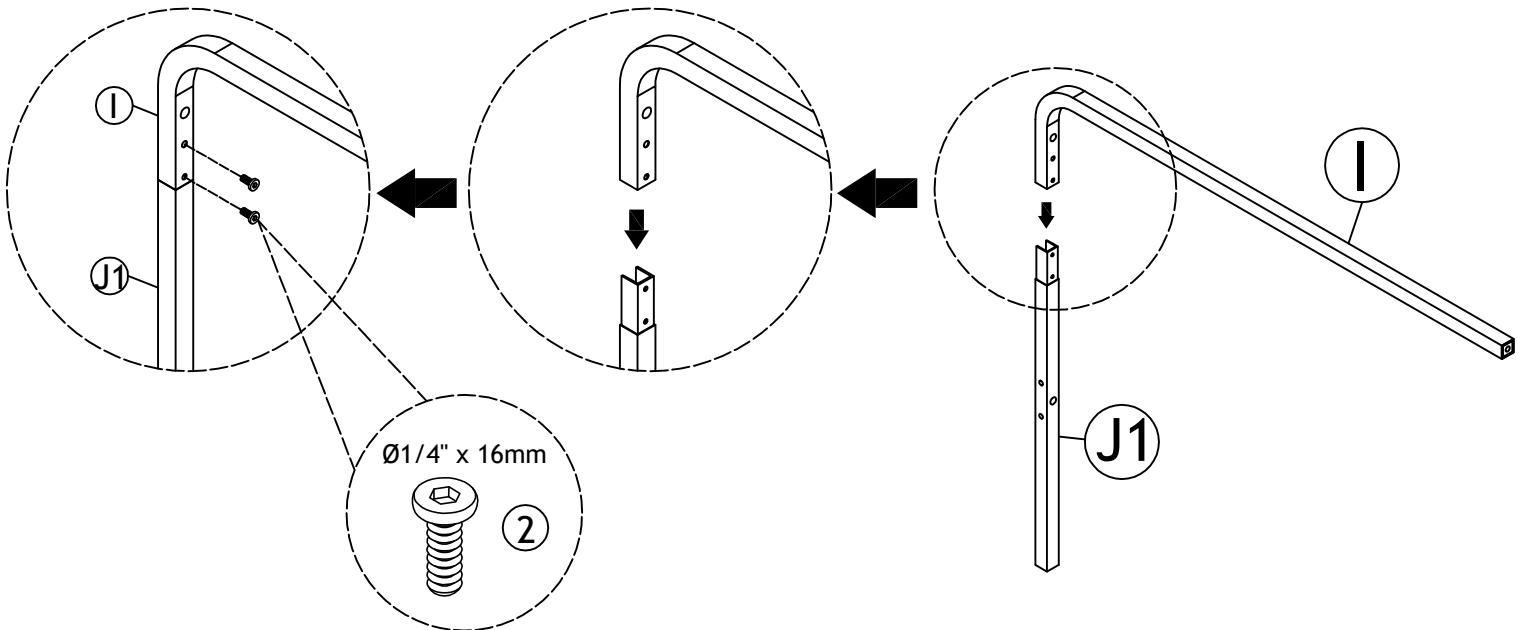
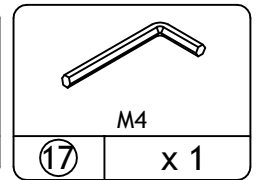
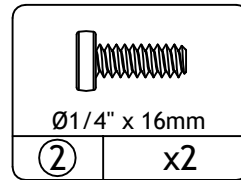
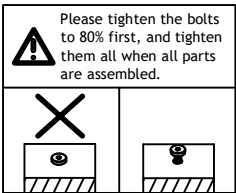

# STEP 7

 Please tighten the bolts to 80% first, and tighten them all when all parts are assembled.

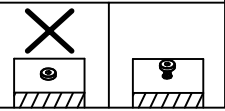

Ø1/4" x 16mm

2	x2
---	----



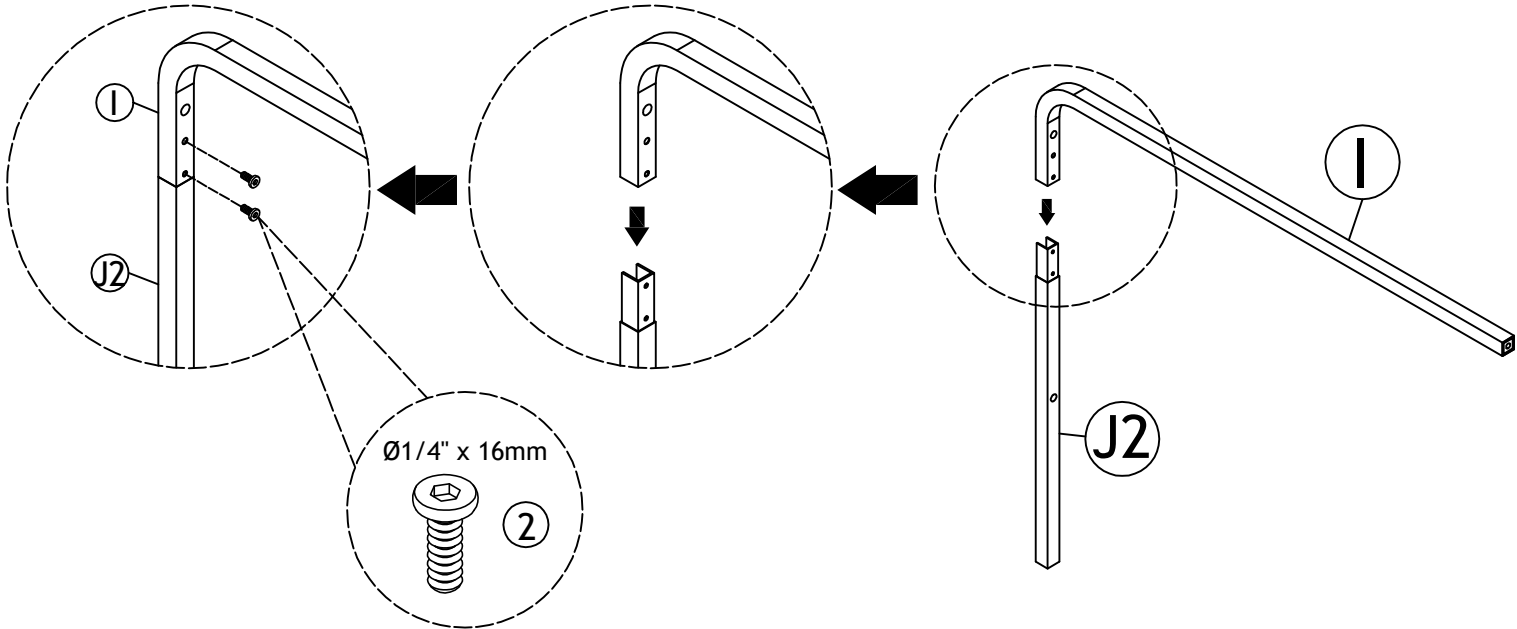

M4

17	x 1
----	-----



# STEP 8

 Please tighten the bolts to 80% first, and tighten them all when all parts are assembled.

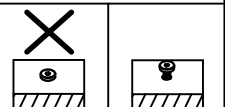

Ø1/4" x 50mm

4	x 4
---	-----



M4

17	x 1
----	-----

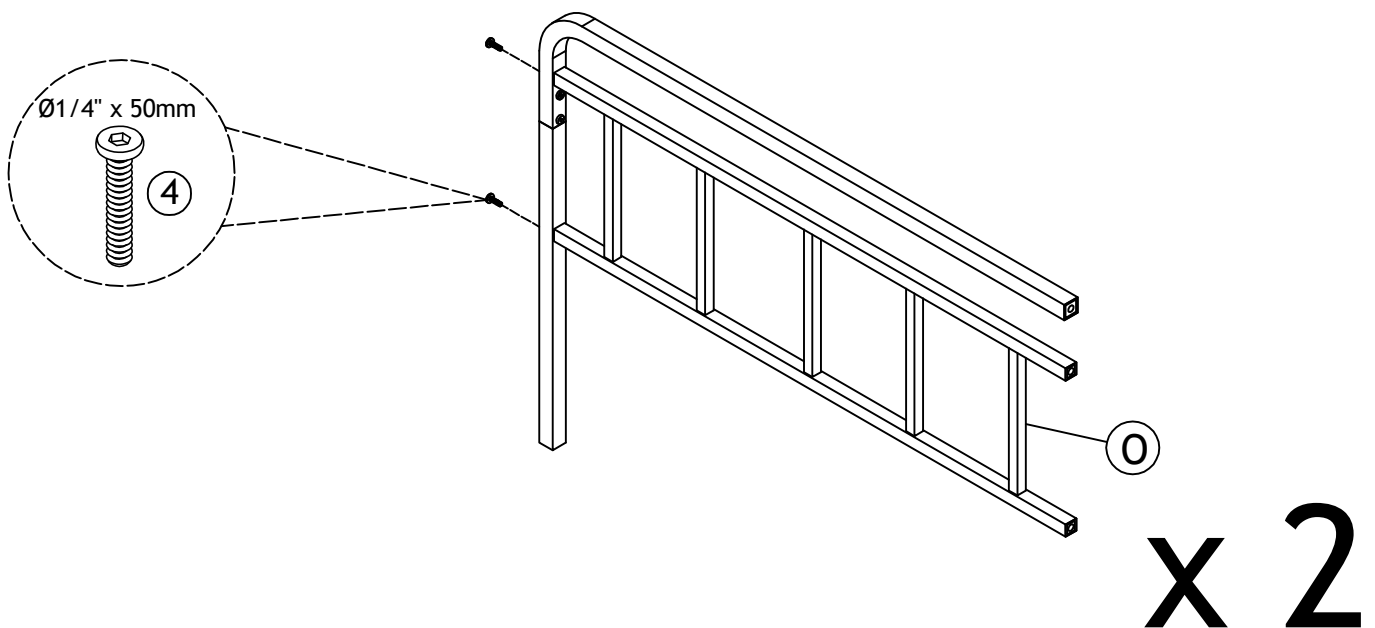

# STEP 9

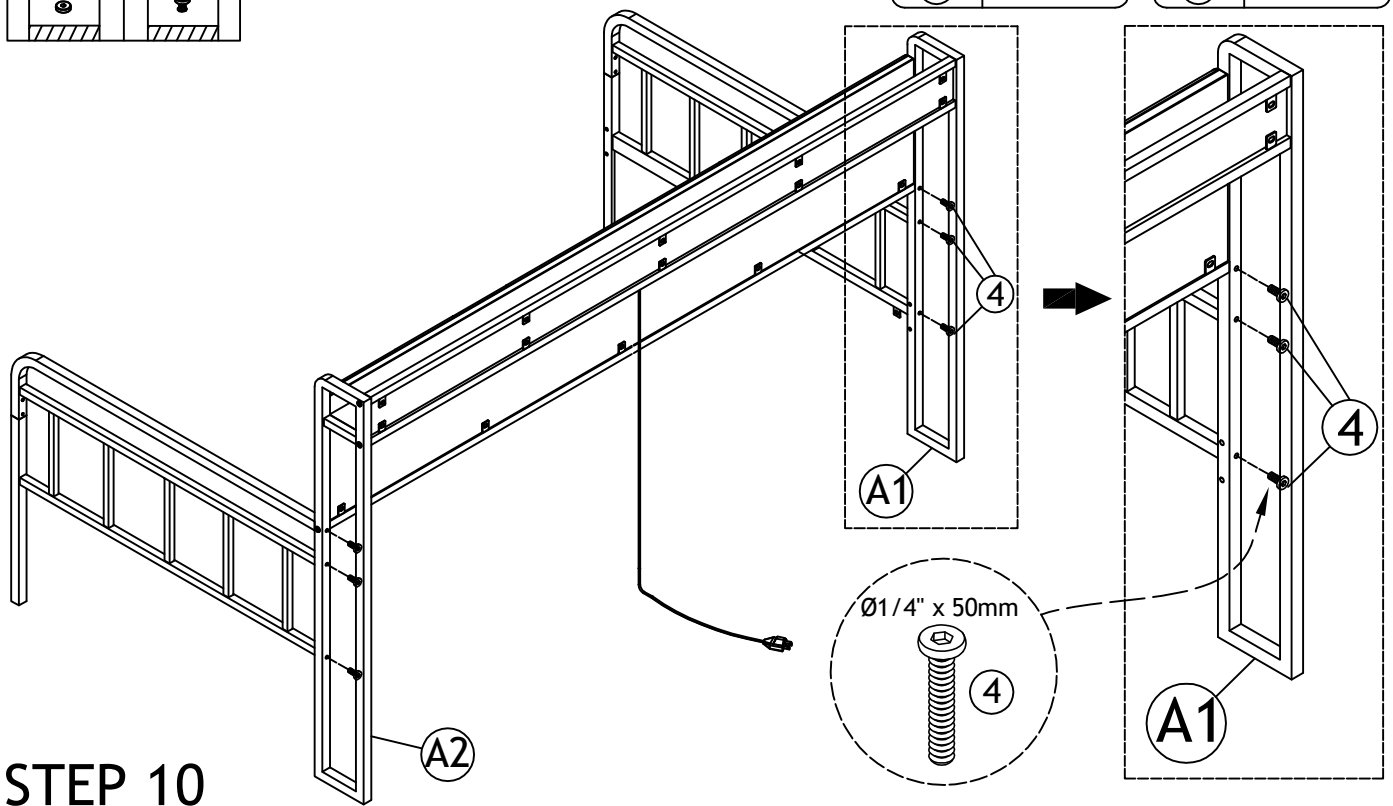
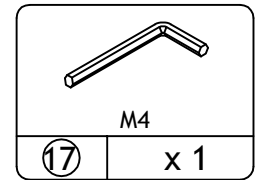
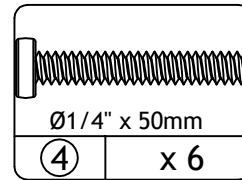
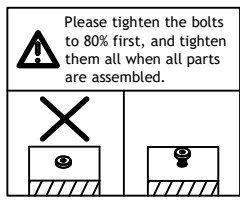

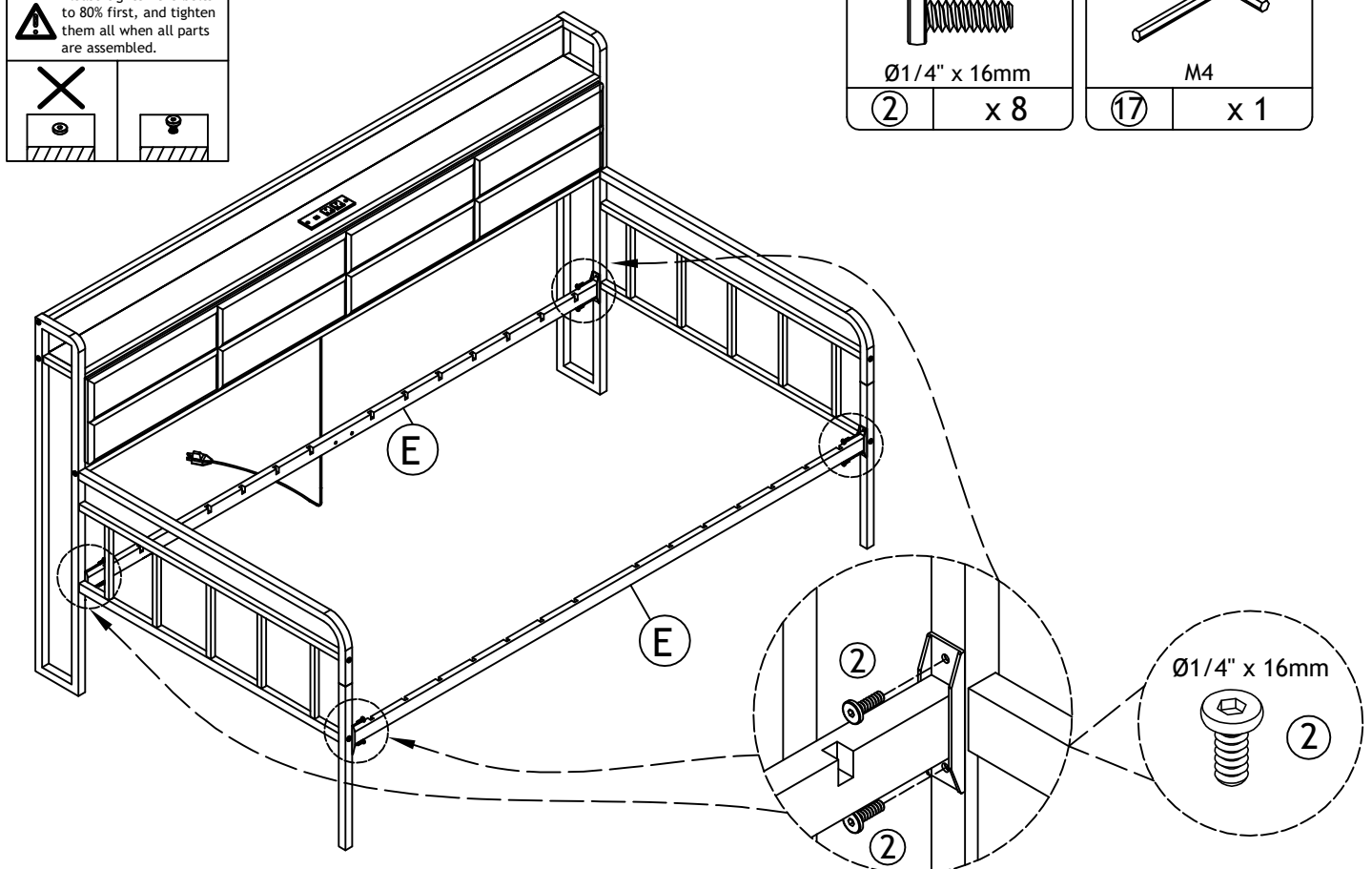
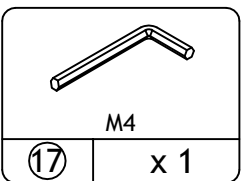
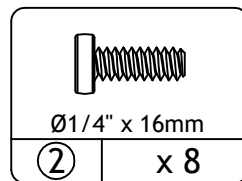
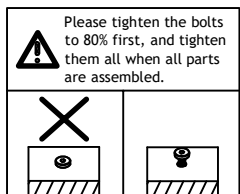

# STEP 10



# STEP 11

 Please tighten the bolts to 80% first, and tighten them all when all parts are assembled.

	
---	---

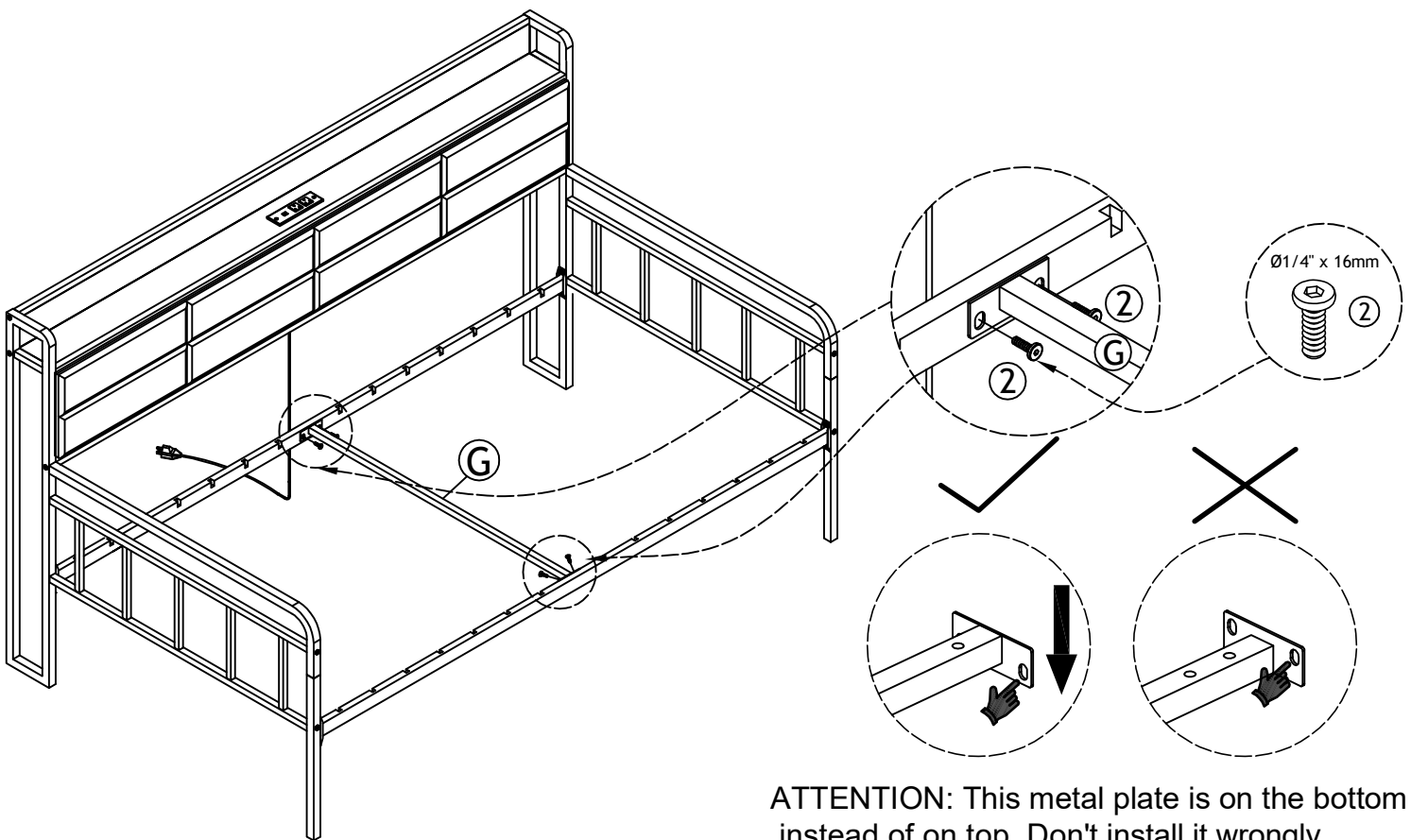

Ø1/4" x 16mm
② x 4

M4
⑰ x 1

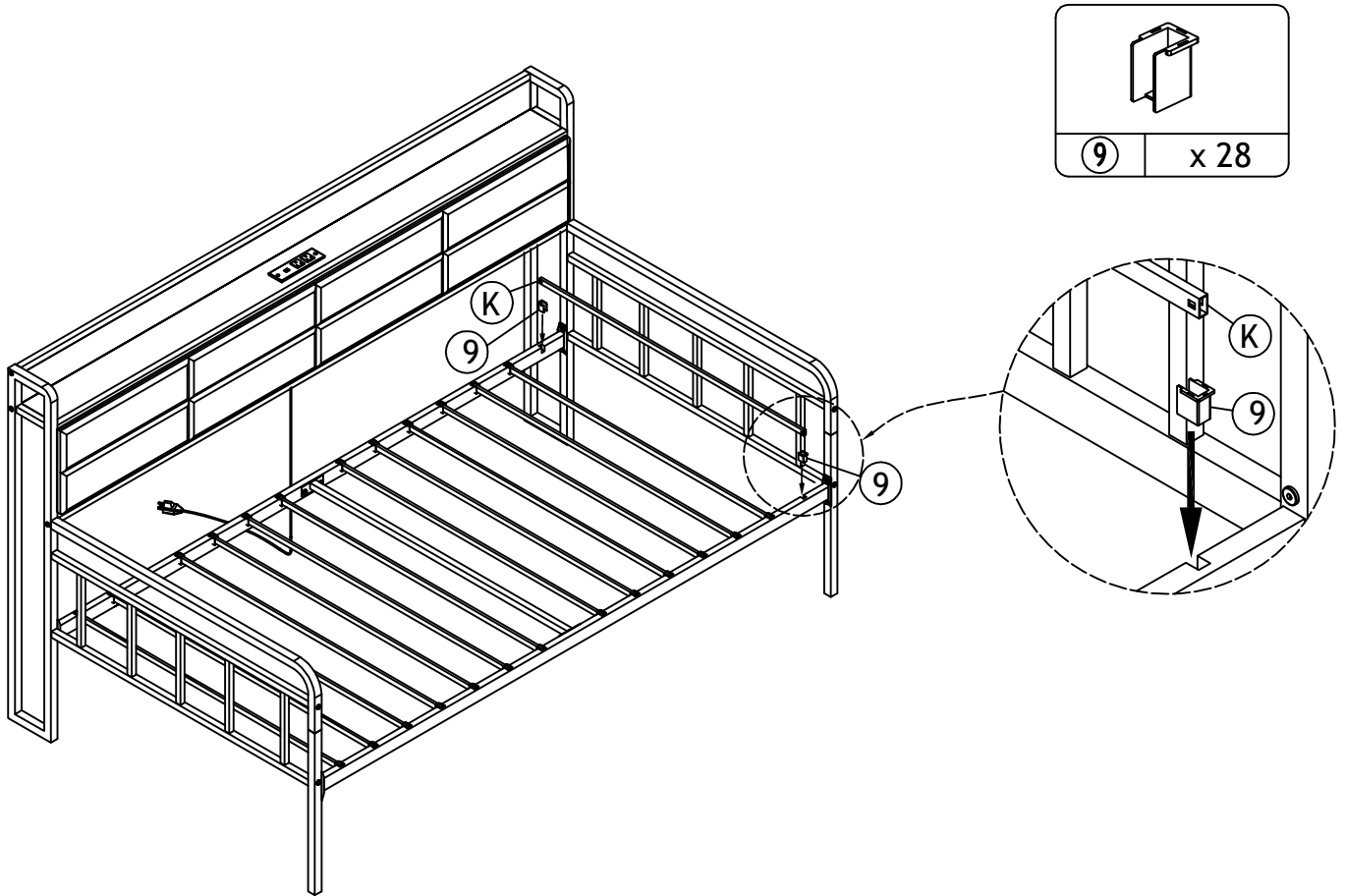

**ATTENTION:** This metal plate is on the bottom instead of on top. Don't install it wrongly.

# STEP 12



## Assemble the slats

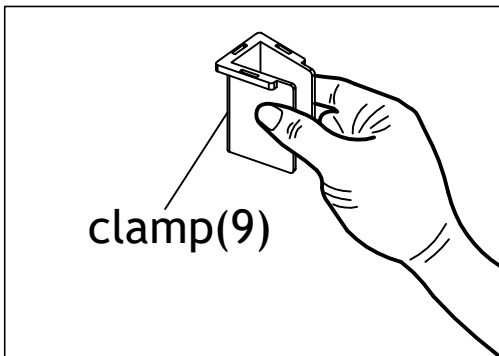

1. Squeeze the clamp (9) tightly.

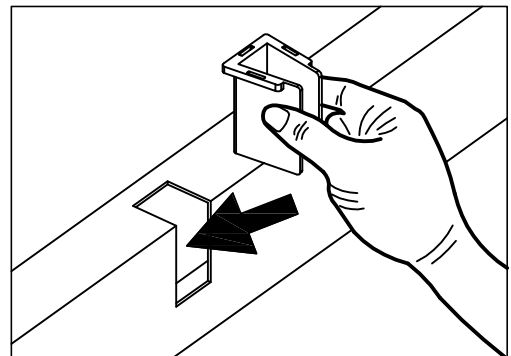

2. Put the clamp into the gaps.

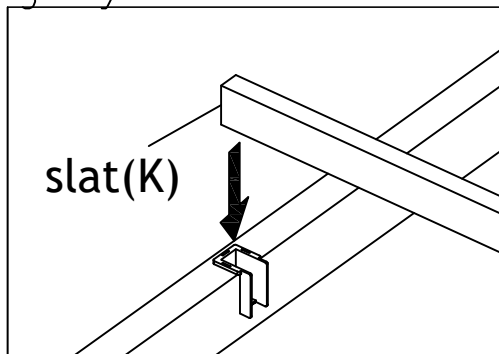

3. Put the slat (K) into the clamp.

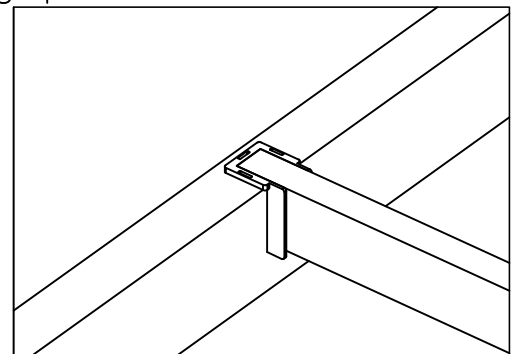

4. Finished.

# STEP 13

 Please tighten the bolts to 80% first, and tighten them all when all parts are assembled.

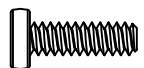
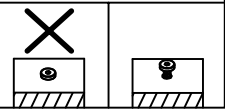

Ø1/4" x 20mm

7	x 8
---	-----



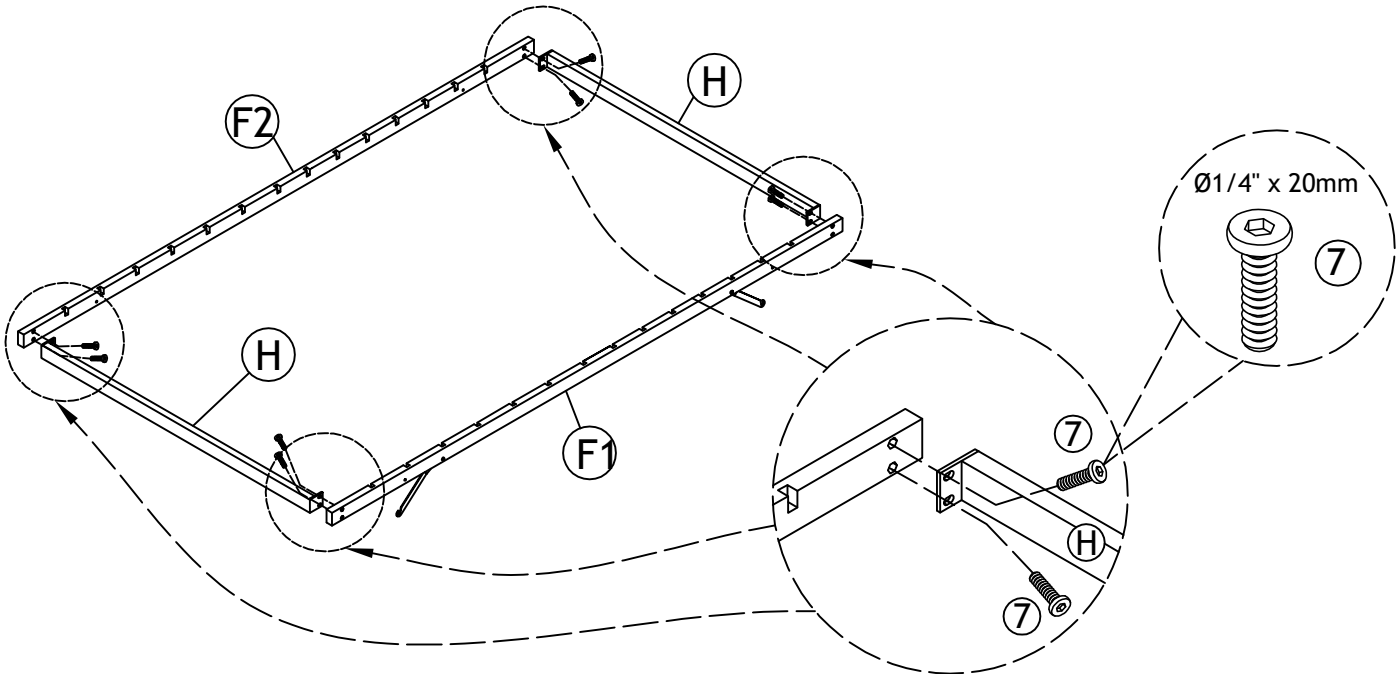

M4

17	x 1
----	-----



# STEP 14

 Please tighten the bolts to 80% first, and tighten them all when all parts are assembled.

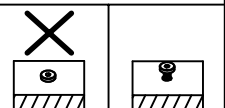

11	x 2
----	-----

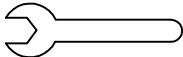

16	x 1
----	-----



14	x 2
----	-----

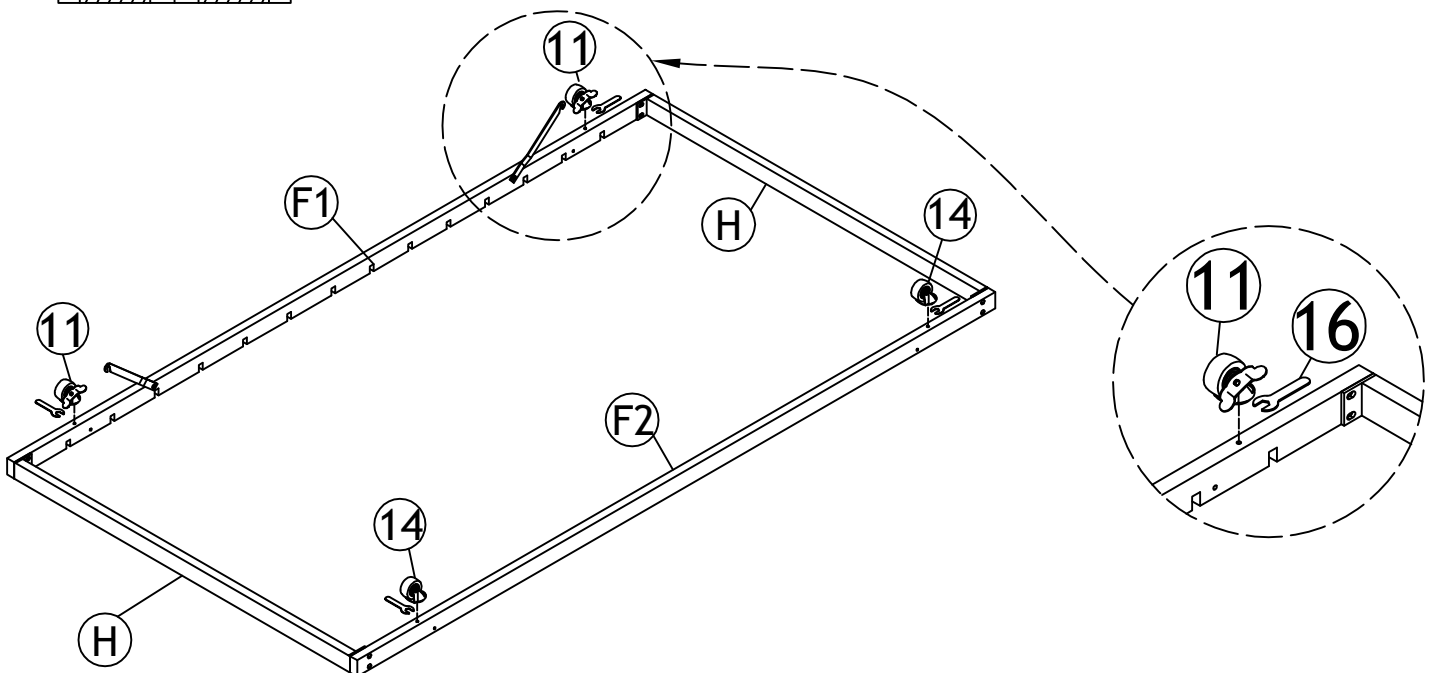

# STEP 15

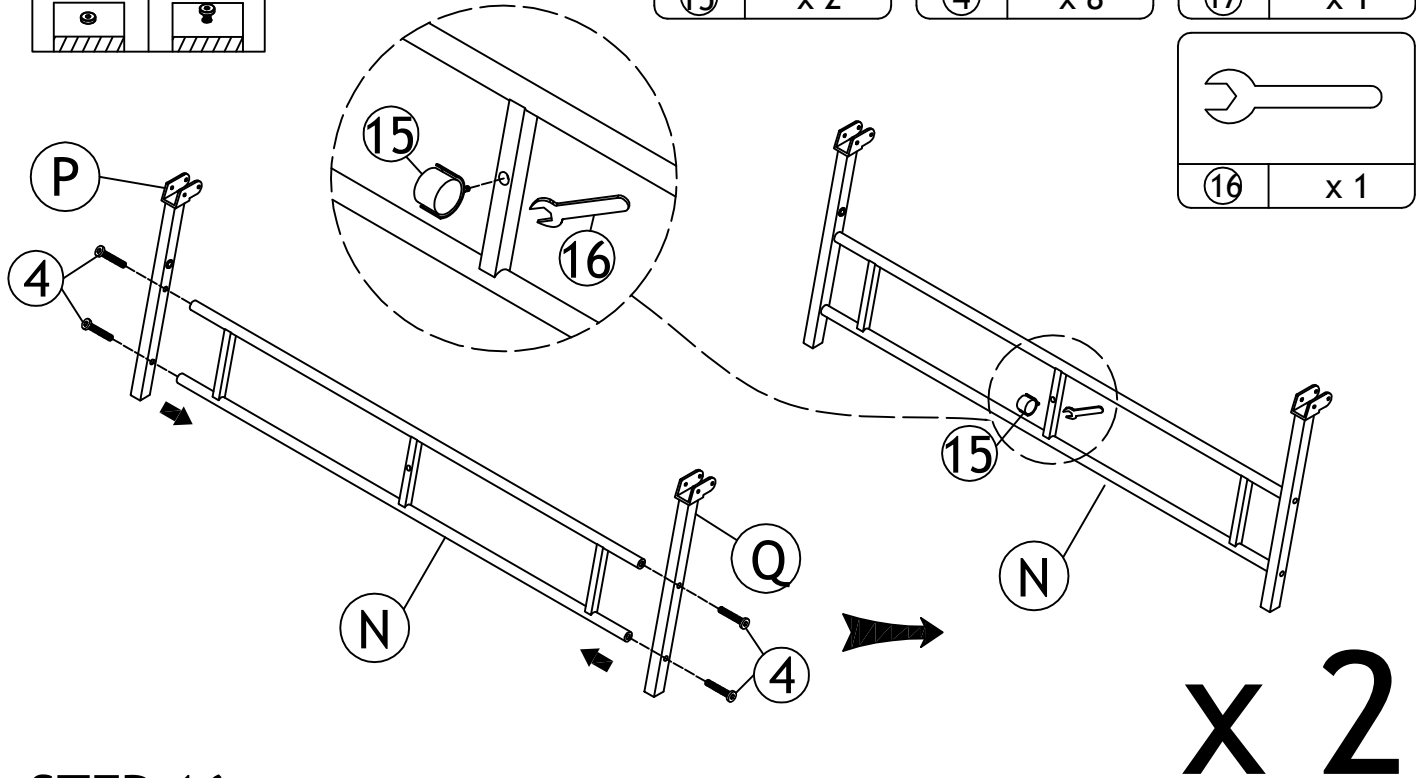
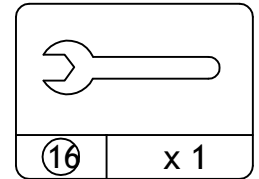
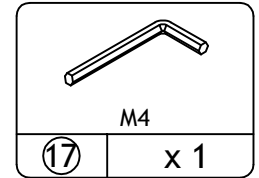
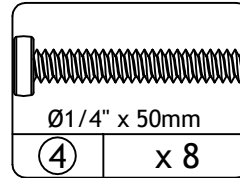
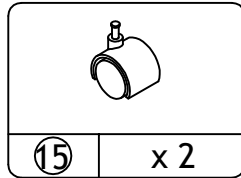
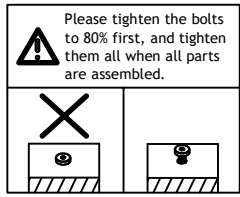

# STEP 16

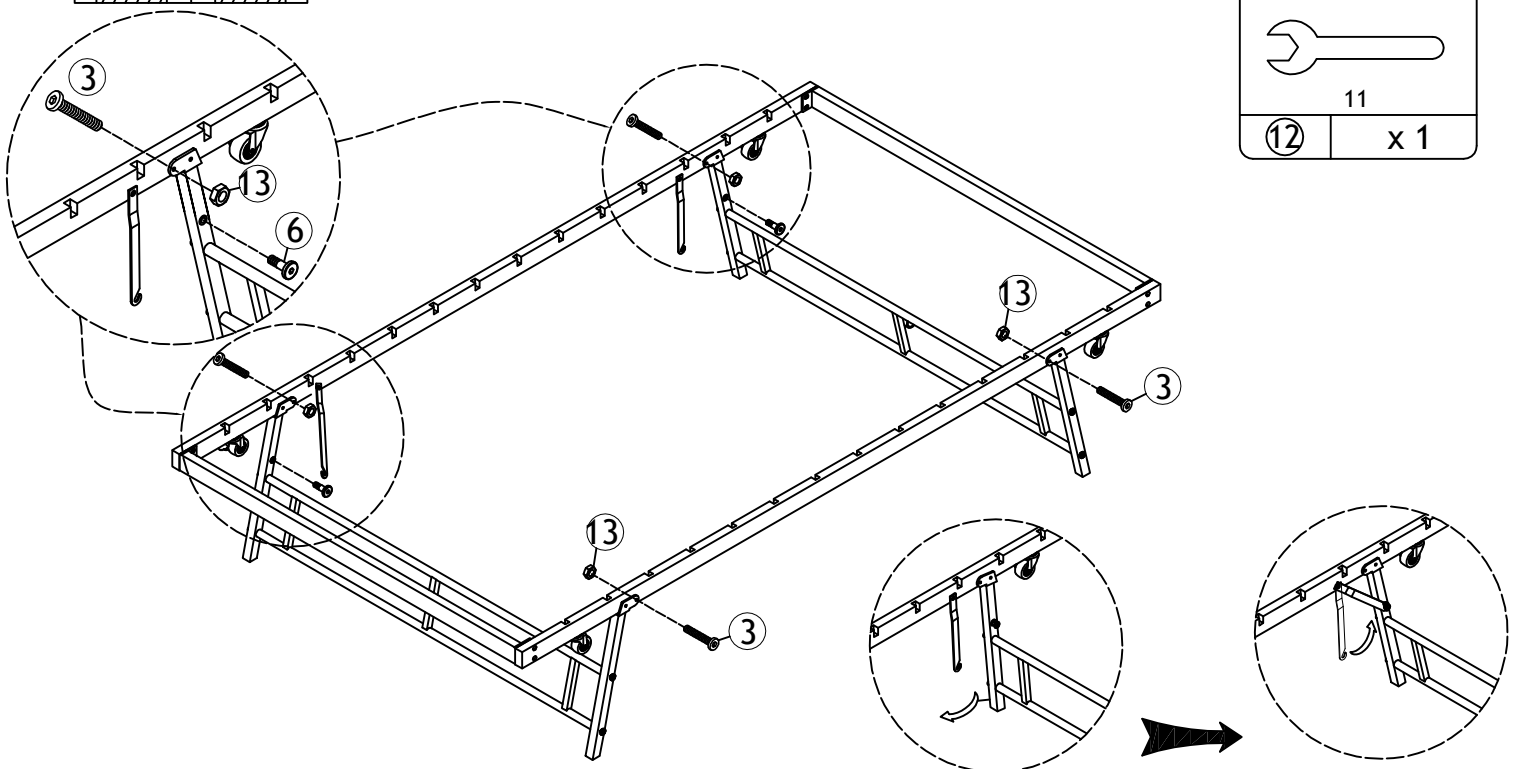
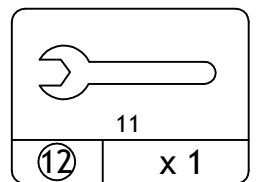
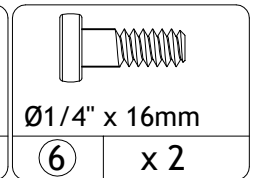
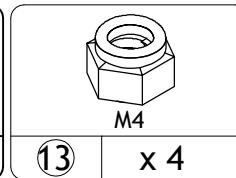
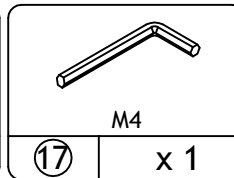
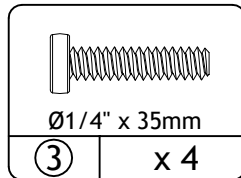
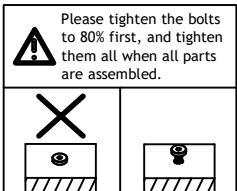

# STEP 17

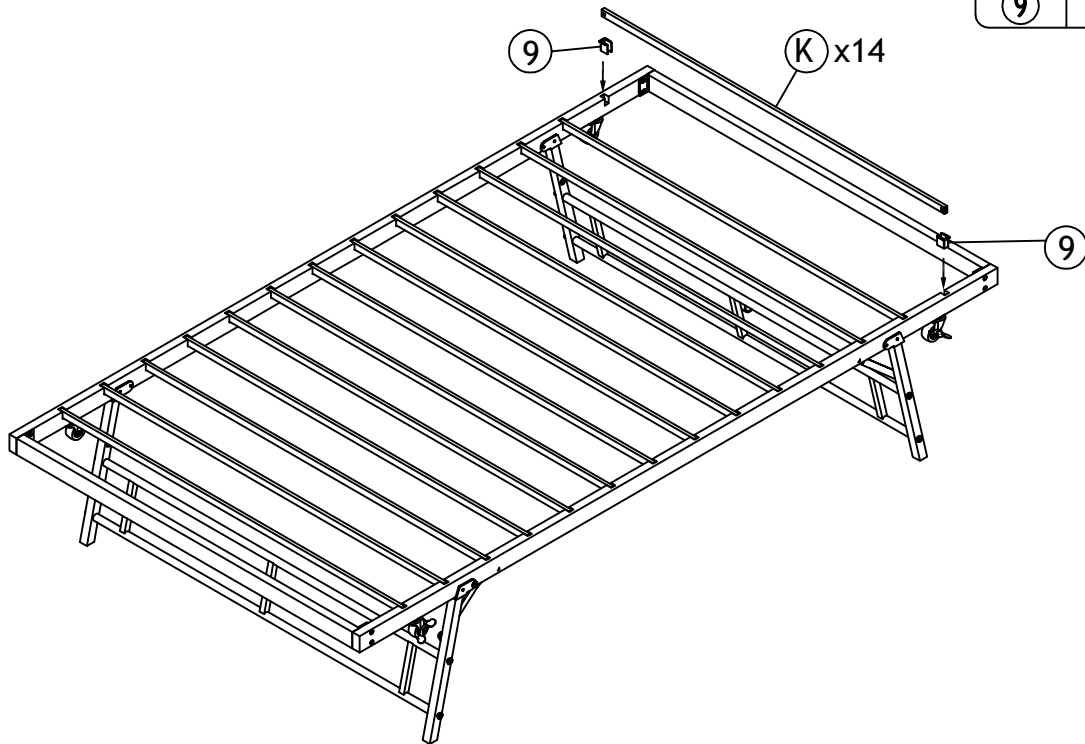
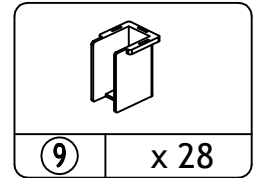

## Assemble the slats

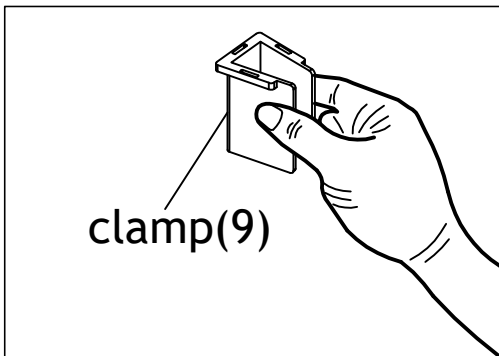

1. Squeeze the clamp (9) tightly.

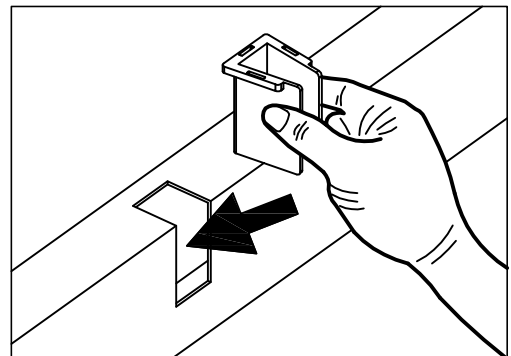

2. Put the clamp into the gaps.

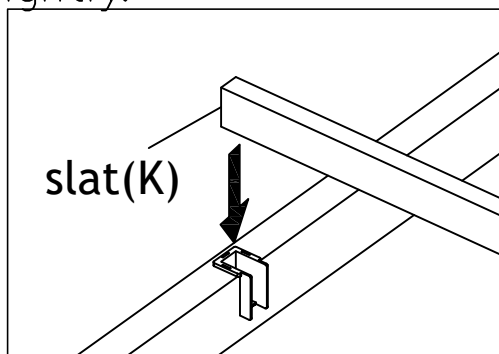

3. Put the slat (K) into the clamp.

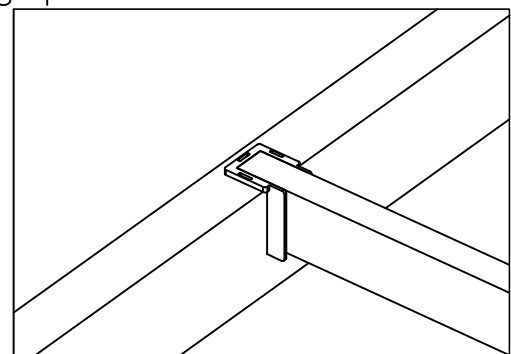

4. Finished.

# STEP 18

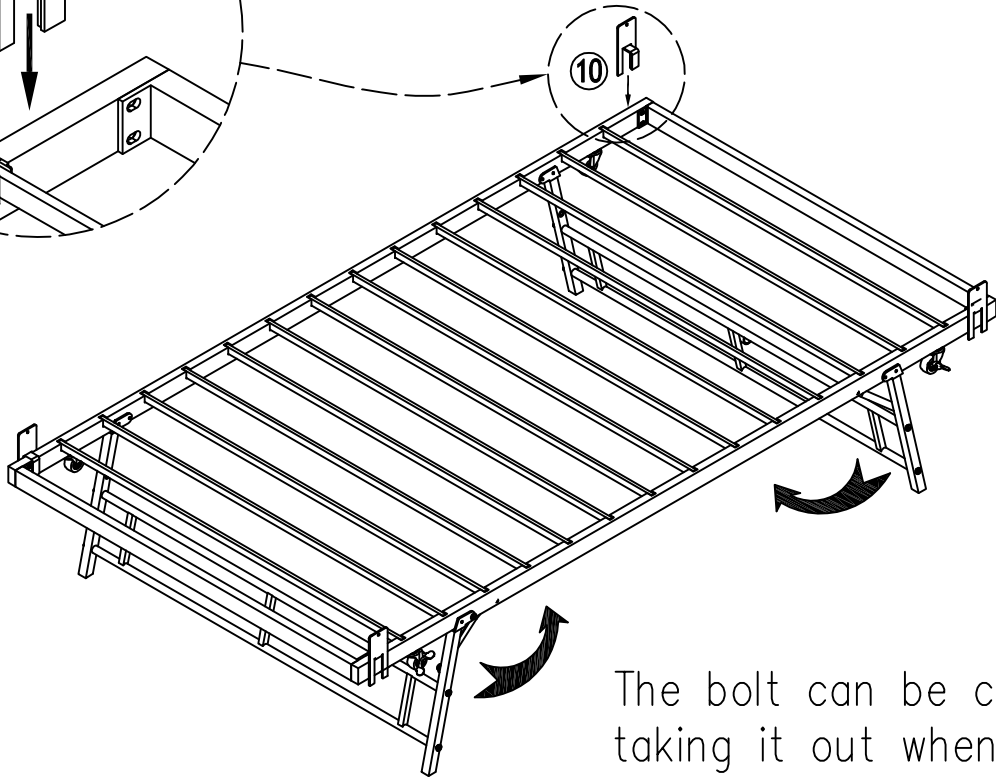
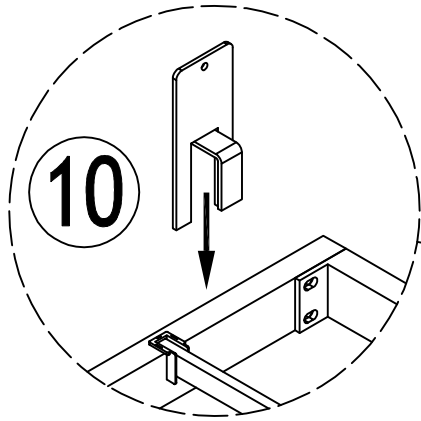
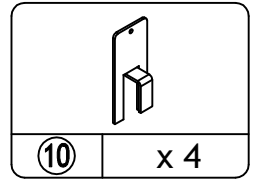

The bolt can be closed by taking it out when the supporting foot is put away

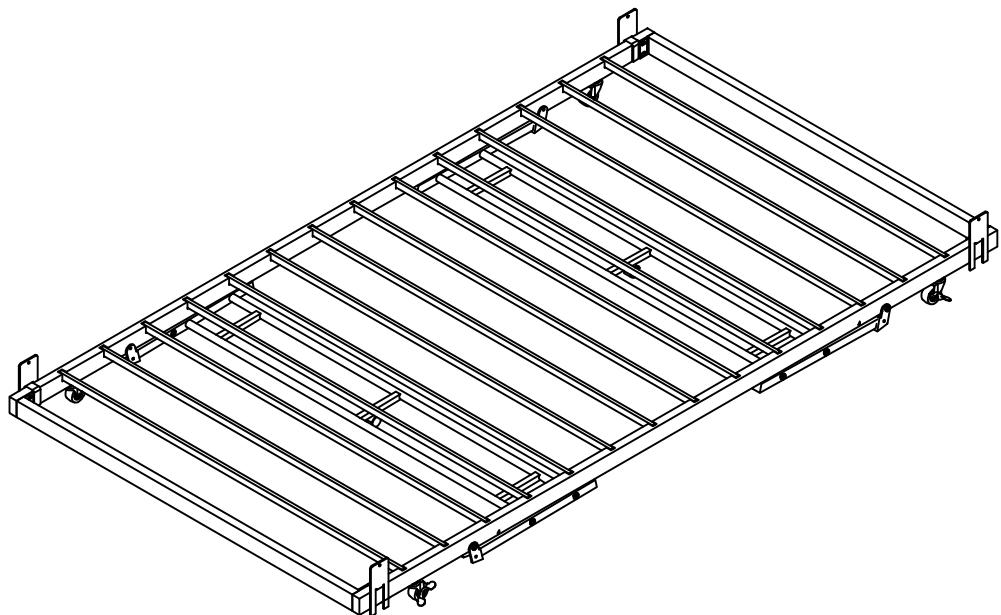

# STEP 19

---

