

IHOMDEC
Assembly instruction
Dining Table
SKU:IHD-DT06

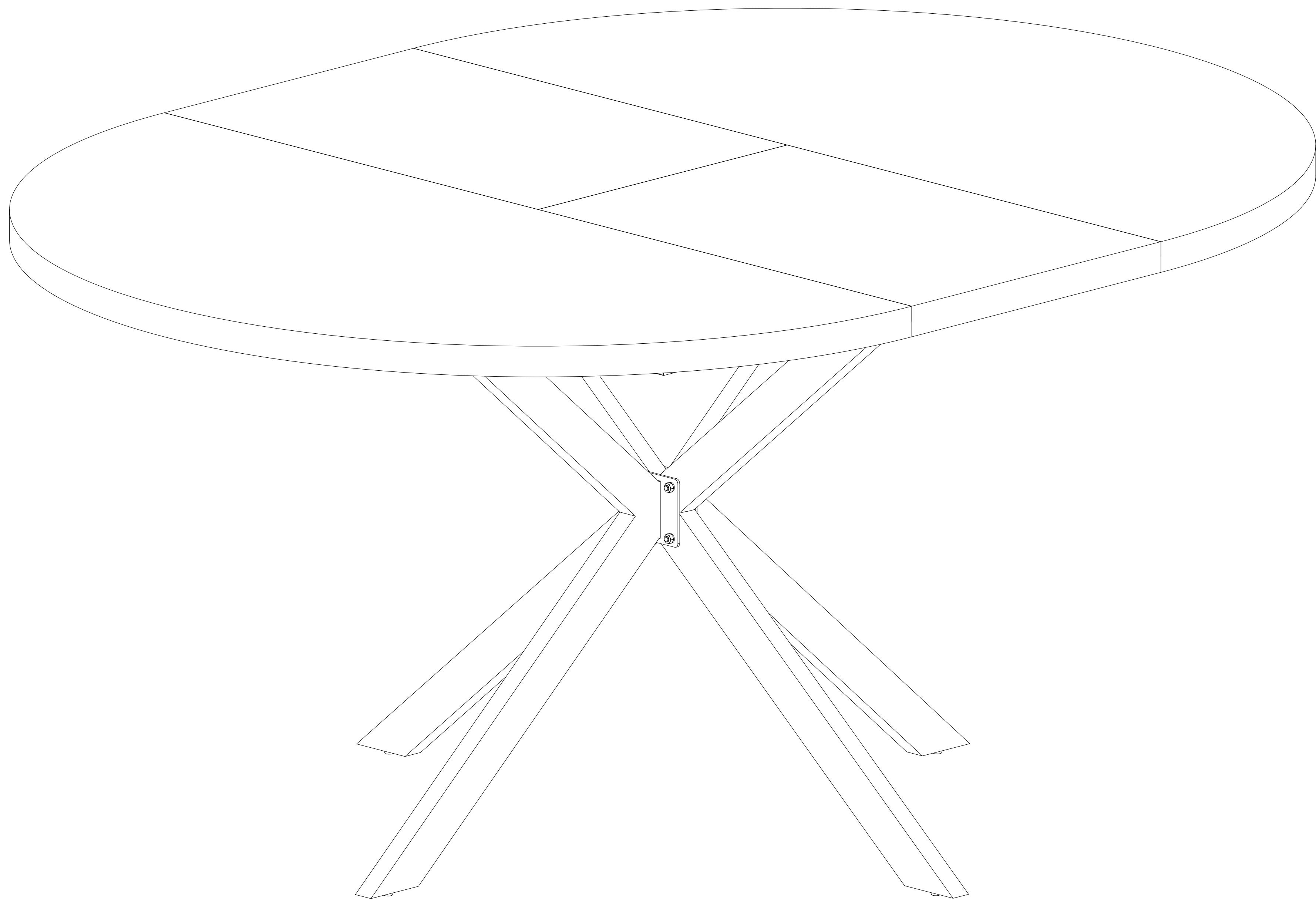

Customer Service Before Return:

If part is missing or damaged, or you need help with assembly,
Please do not hesitate to contact us.

SELLER CONTACT INFORMATION:

contacts@ihomdec.com

IHD25-ZZHY-05



Before Assembly

IMPORTANT NOTE:

- Make sure parts hardware are included and free of obvious defect before disposing of any packaging
- Place all wooden parts on a clean and smooth surface such as a rug or carpet to avoid the parts from being scratched.
- DO NOT tighten all screws and bolts until completely assembled.
- Assembly will require two people.

PART LIST

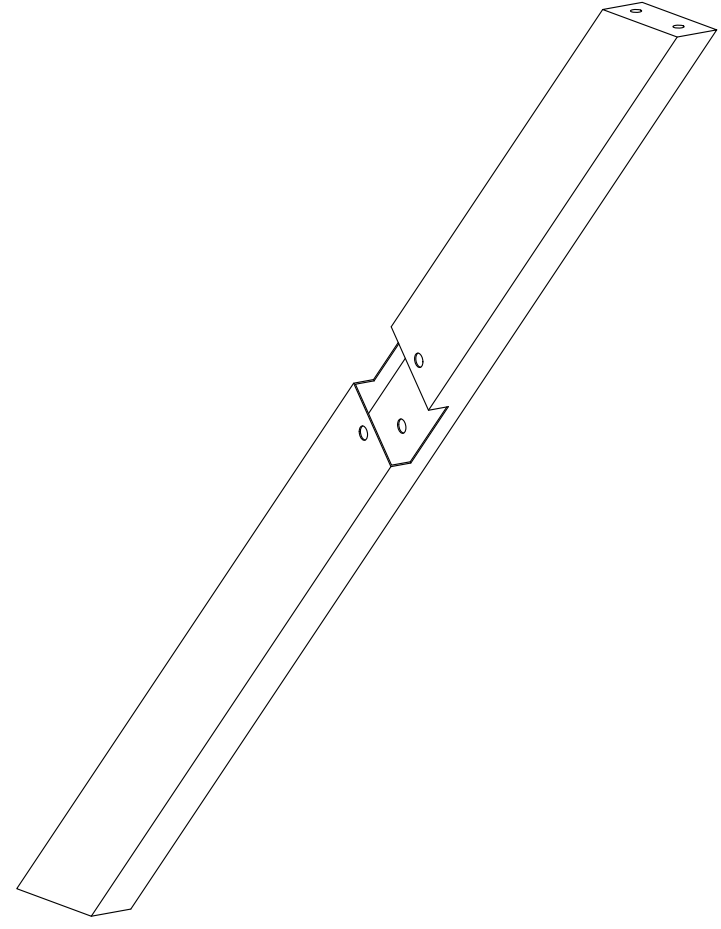
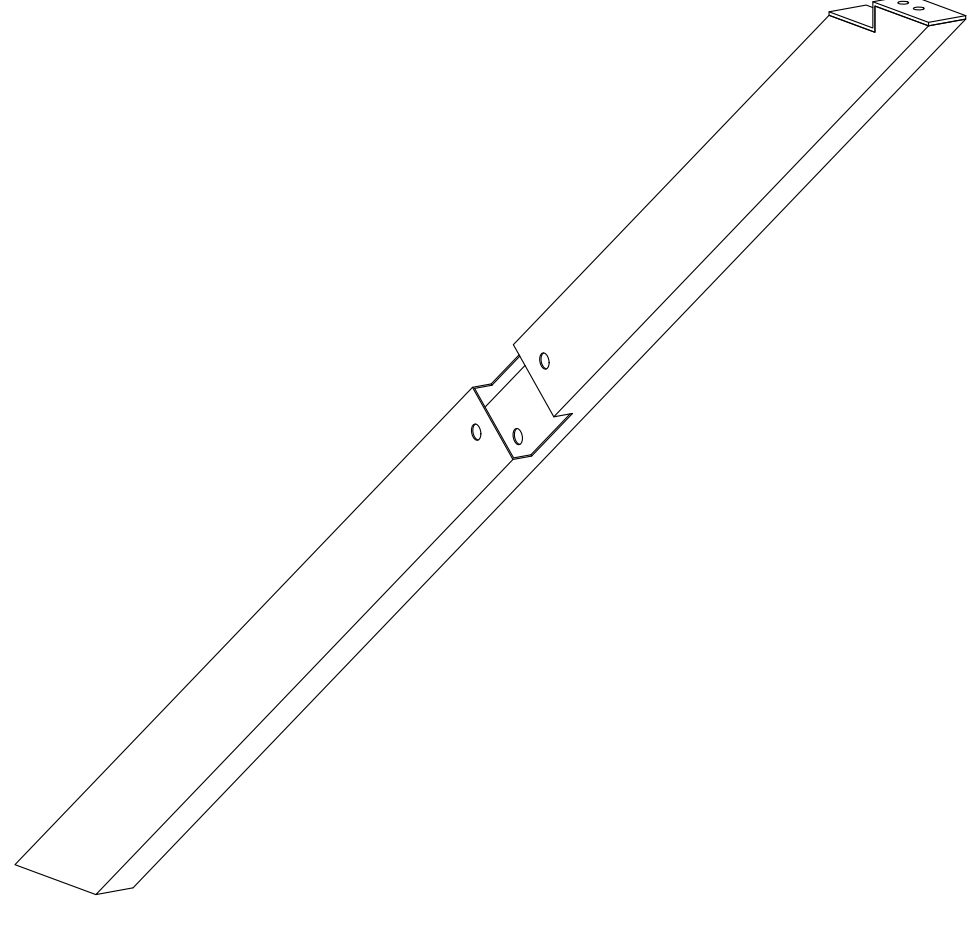
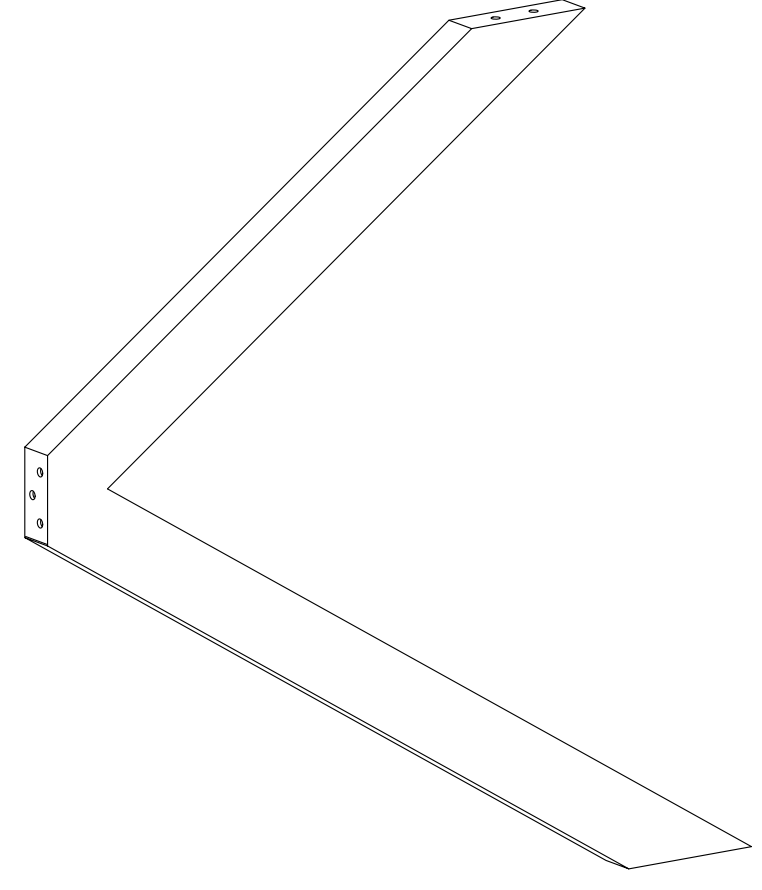
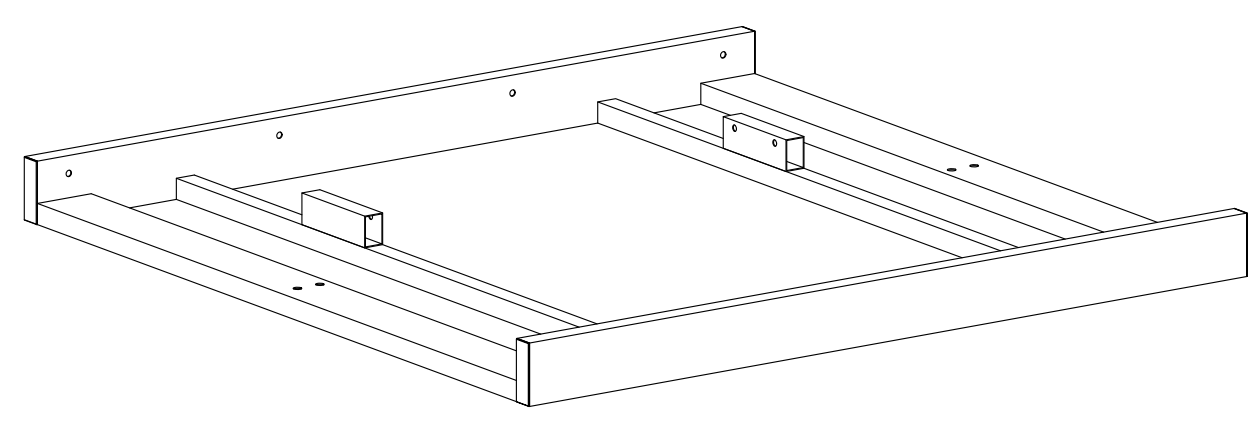
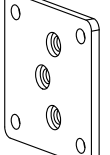
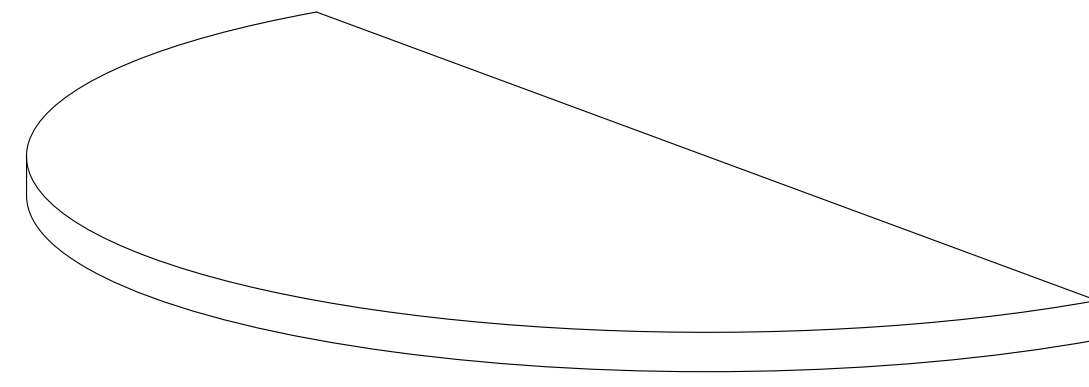
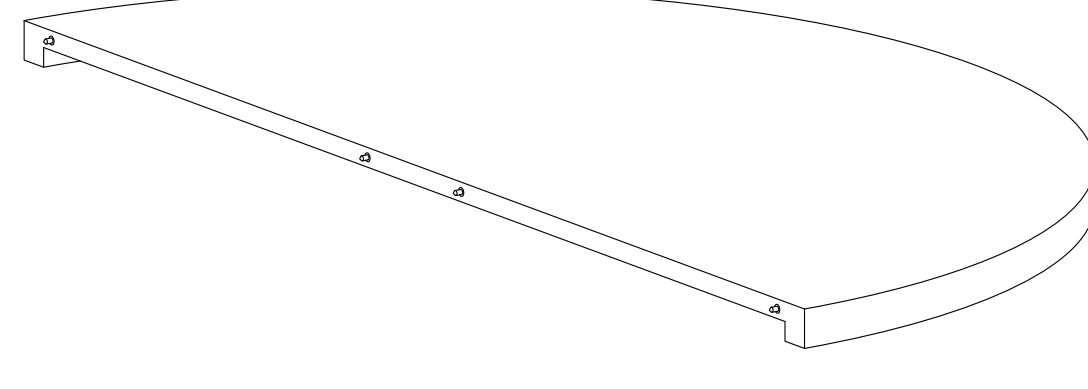
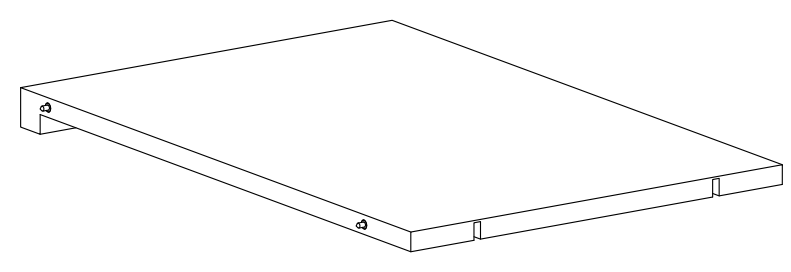
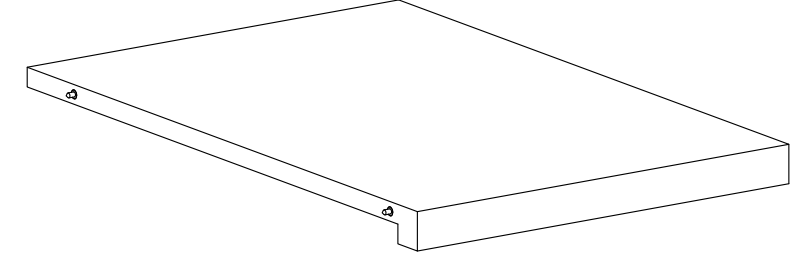
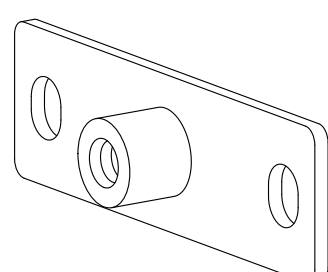
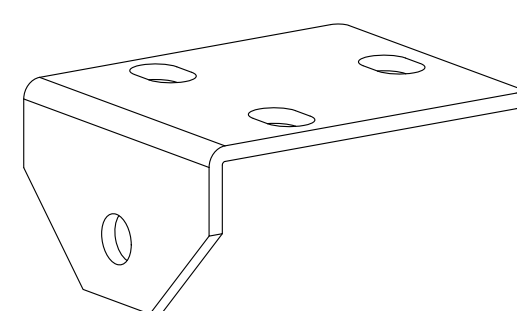
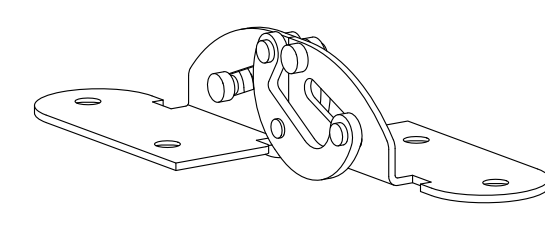
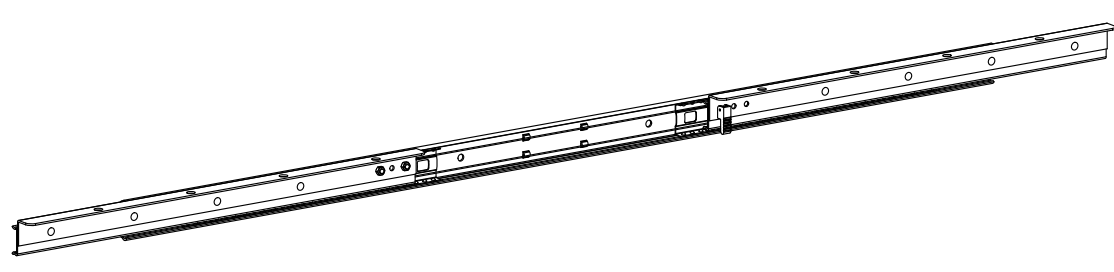
			
1PC	1PC	2PCS	1PC
			
2PCS	1PC	1PC	1PC
			
1PC	2PCS	2PCS	2PCS
			
2PCS			

HARDWARE LIST

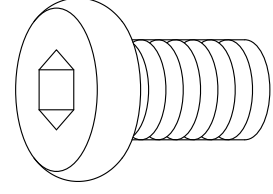
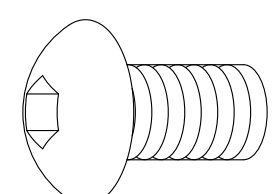
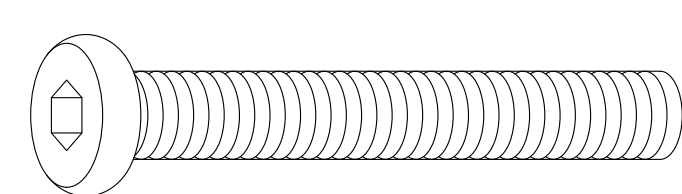
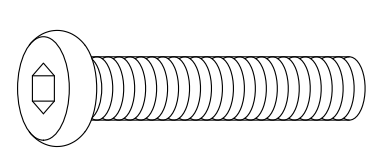
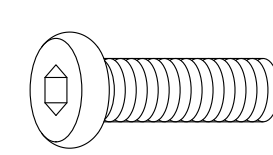
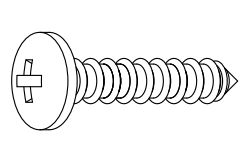
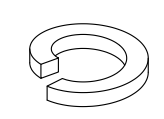
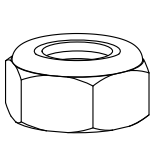
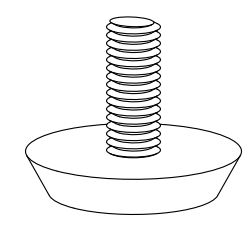
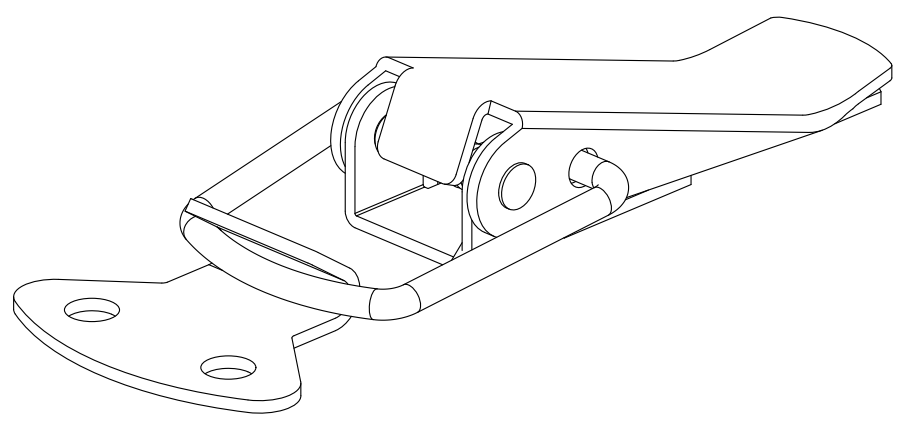
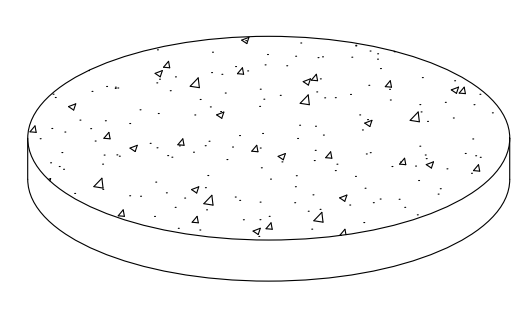
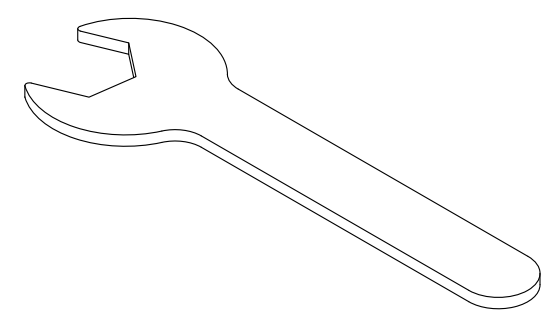
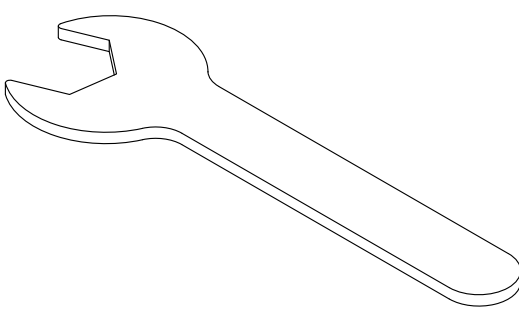
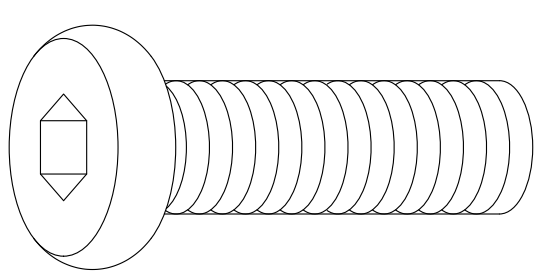
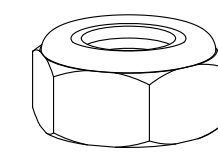
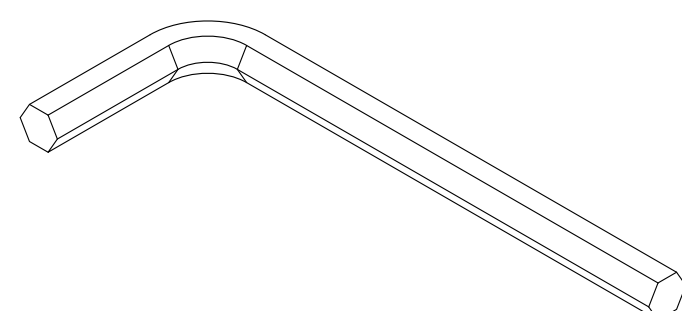
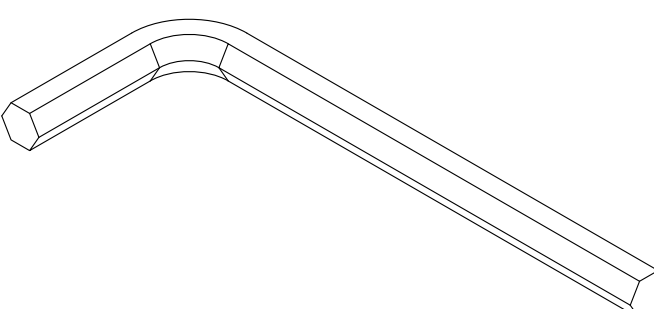
<p>A</p>  <p>M6 x 12mm</p>	<p>B</p>  <p>M6 x 12mm</p>	<p>C</p>  <p>M6 x 45mm</p>	<p>D</p>  <p>M6 x 35mm</p>
<p>14PCS</p>		<p>26PCS</p>	
<p>E</p>  <p>M6 x 20mm</p>	<p>F</p>  <p>Ø4 x 14mm</p>	<p>G</p>  <p>M6</p>	<p>H</p>  <p>M6</p>
<p>4PCS</p>		<p>24PCS</p>	
<p>J</p>  <p>Ø20</p>	<p>K</p> 	<p>L</p>  <p>Ø30</p>	<p>M</p>  <p>10mm</p>
<p>4PCS</p>		<p>4PCS</p>	
<p>N</p>  <p>14mm</p>	<p>O</p>  <p>M8 x 25mm</p>	<p>P</p>  <p>M8</p>	<p>Q</p>  <p>5mm</p>
<p>1PC</p>		<p>2PCS</p>	
<p>R</p>  <p>4mm</p>			
<p>2PCS</p>			

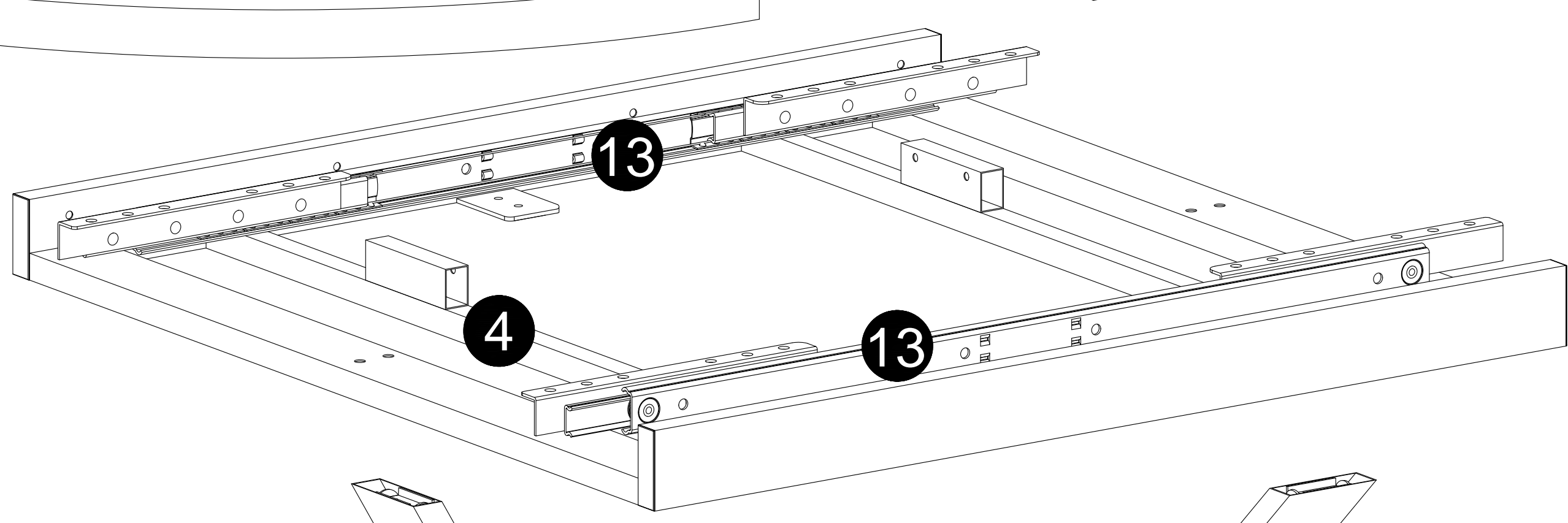
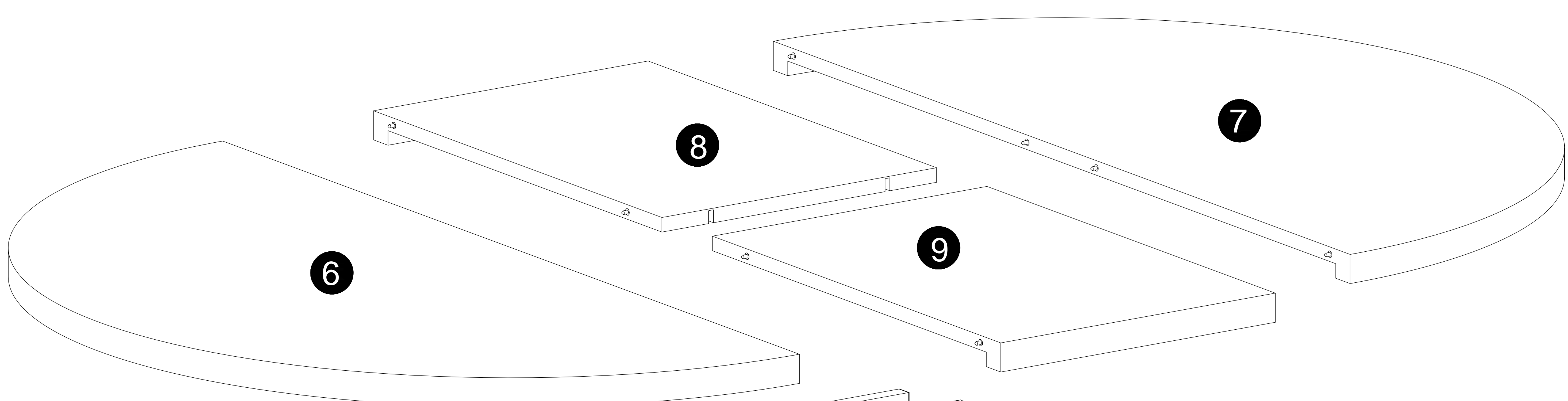

10
x 2

11
x 2

12
x 2

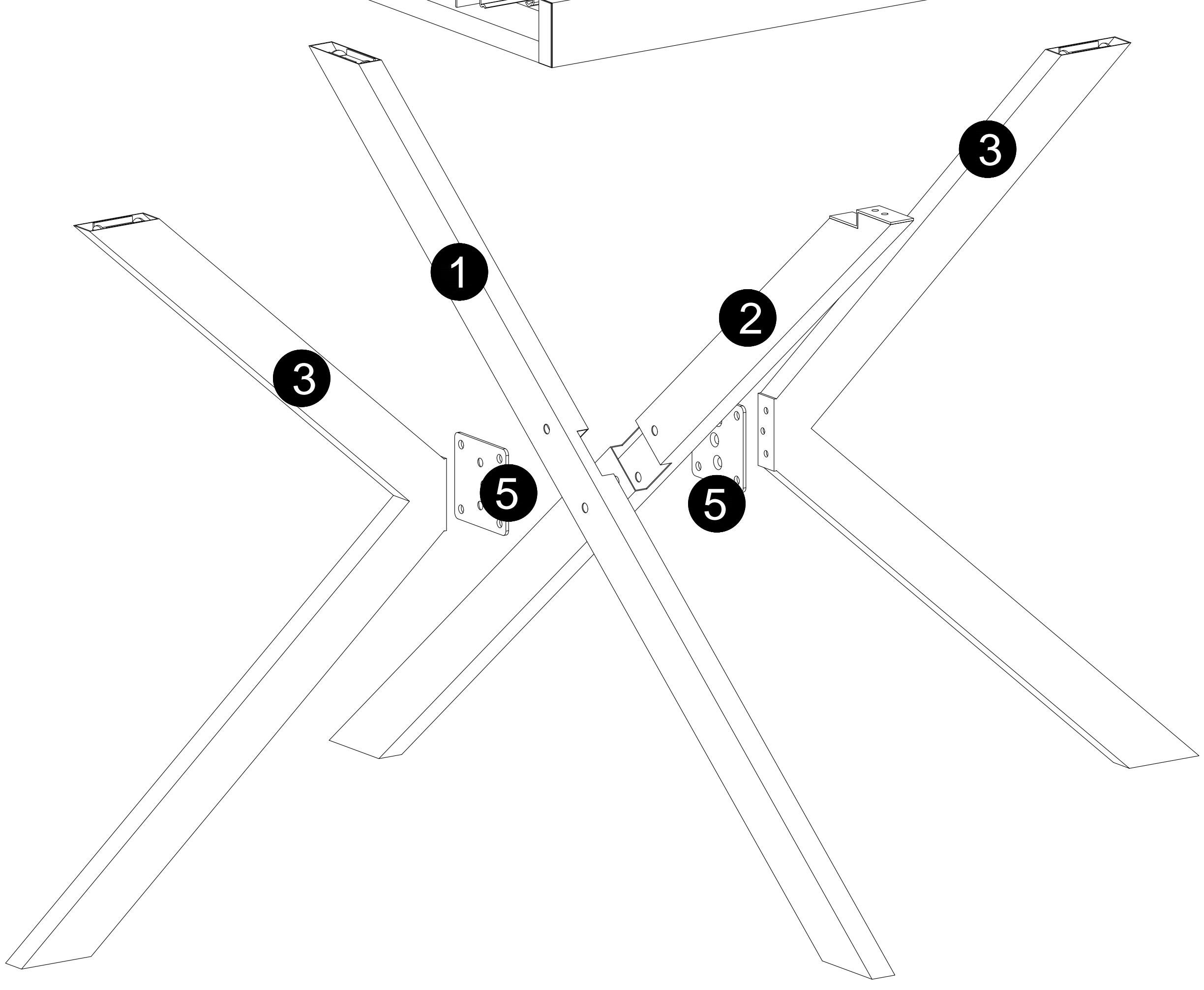

NOTED:

1. Do not fully tighten all bolts until all parts are in place. Failure to follow these instructions may cause the bolt to misalign during assembly.

2. To prevent injury and property damaged from unexpected tipping of furniture, we highly recommend installation of the anti-tip kit included with this product.

Step 1

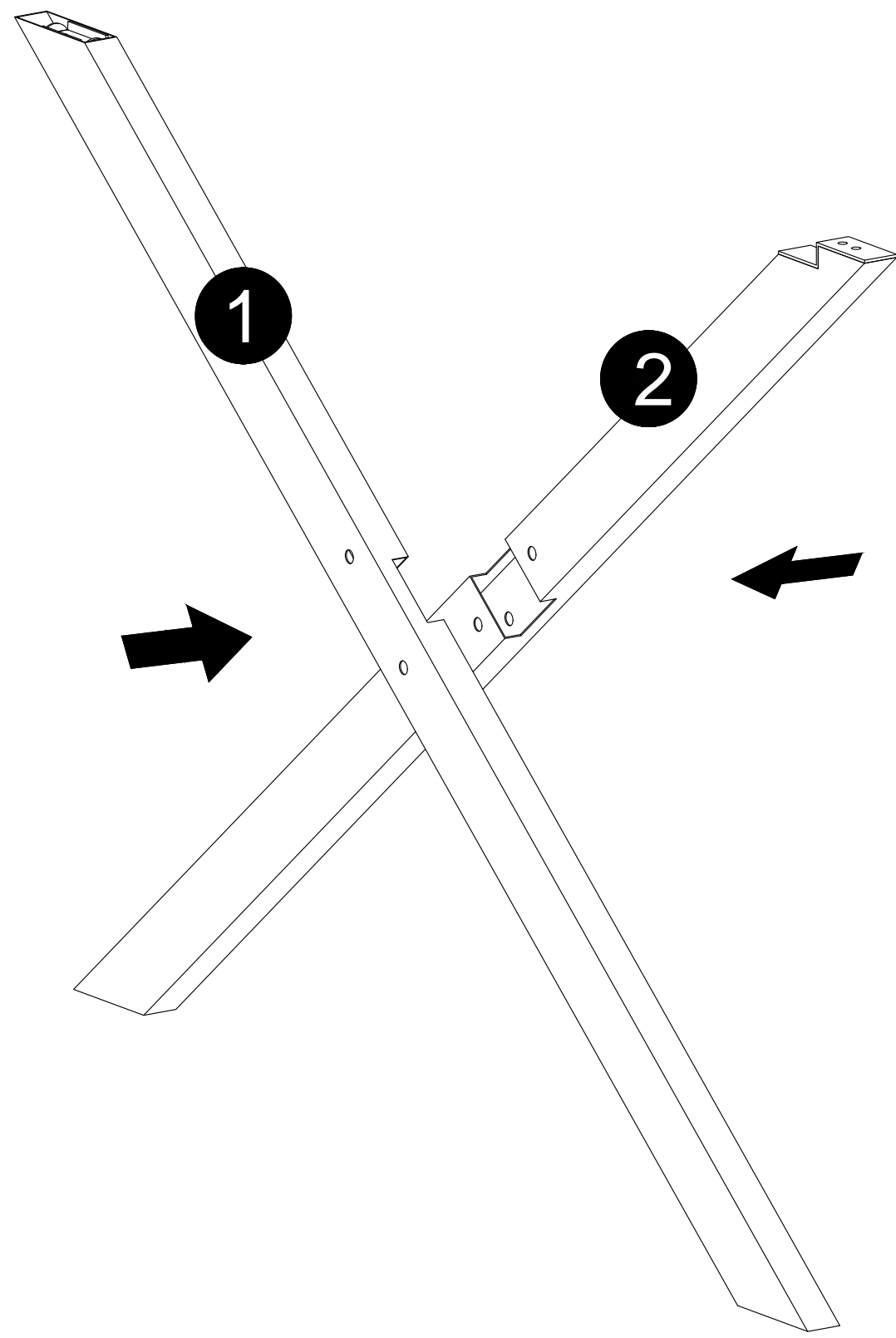

Step 2

YOU WILL NEED

Ax6

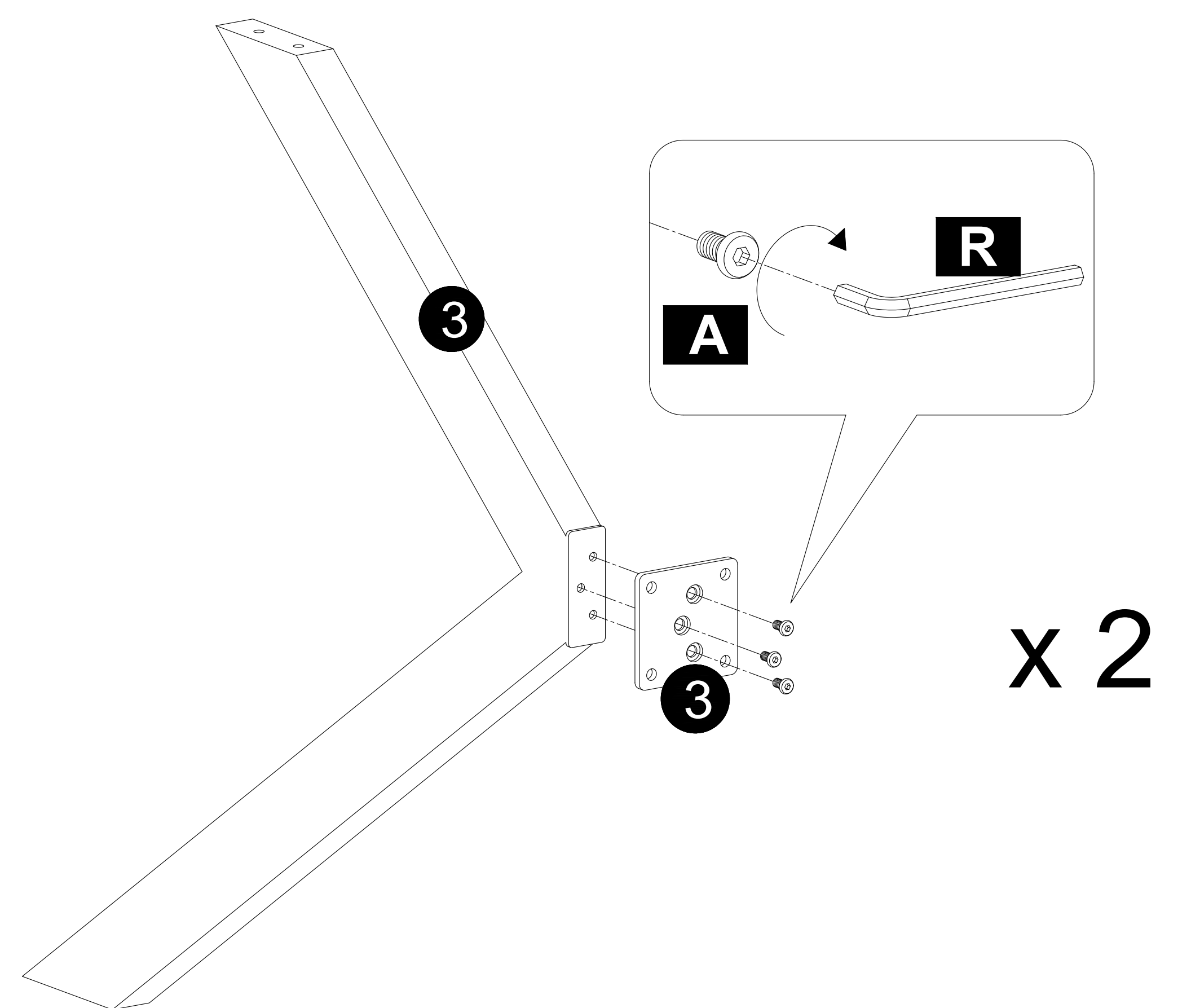

Step 3

YOU WILL NEED

Cx4 / Hx4 / Gx4

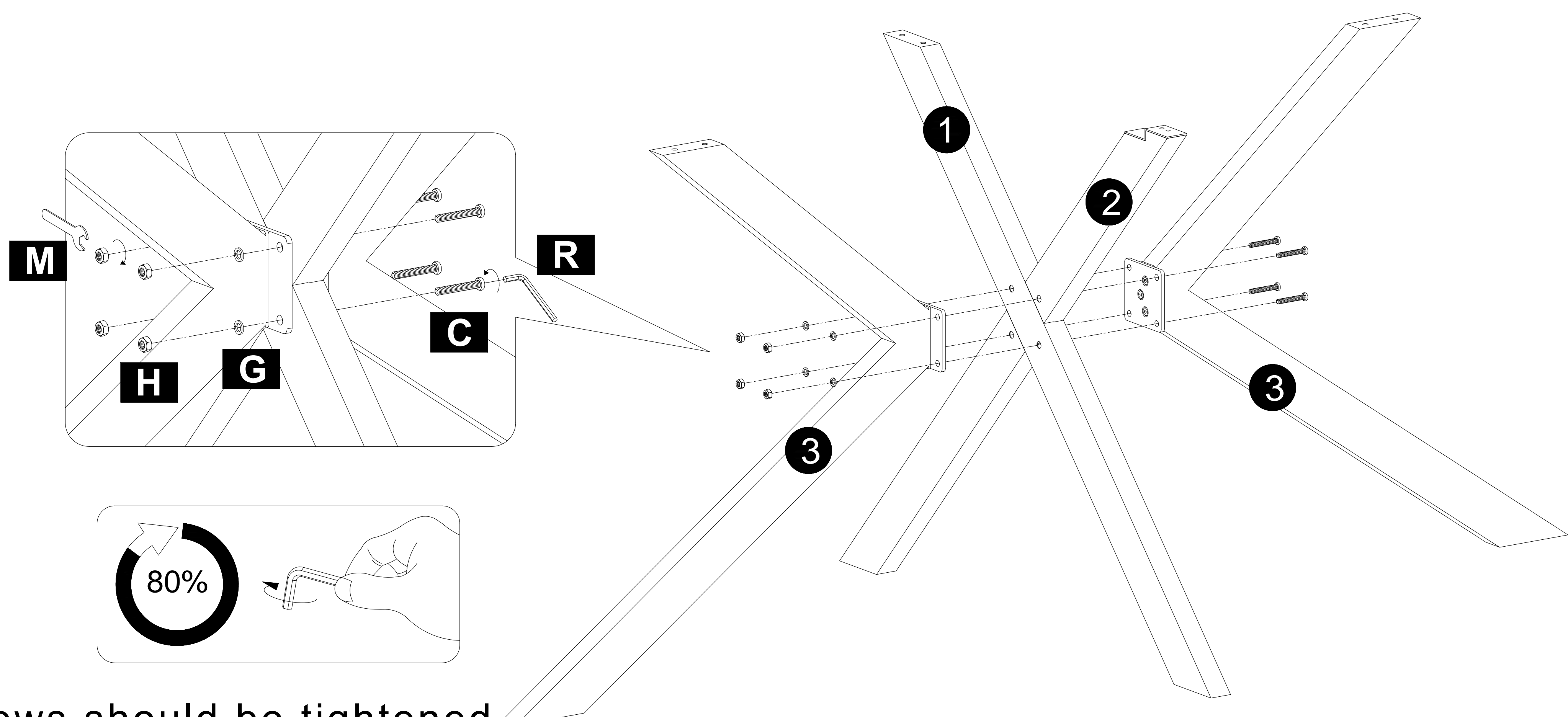

The screws should be tightened to about 80%, not fully tightened.

Step 4

YOU WILL NEED
Dx4 / Ex4

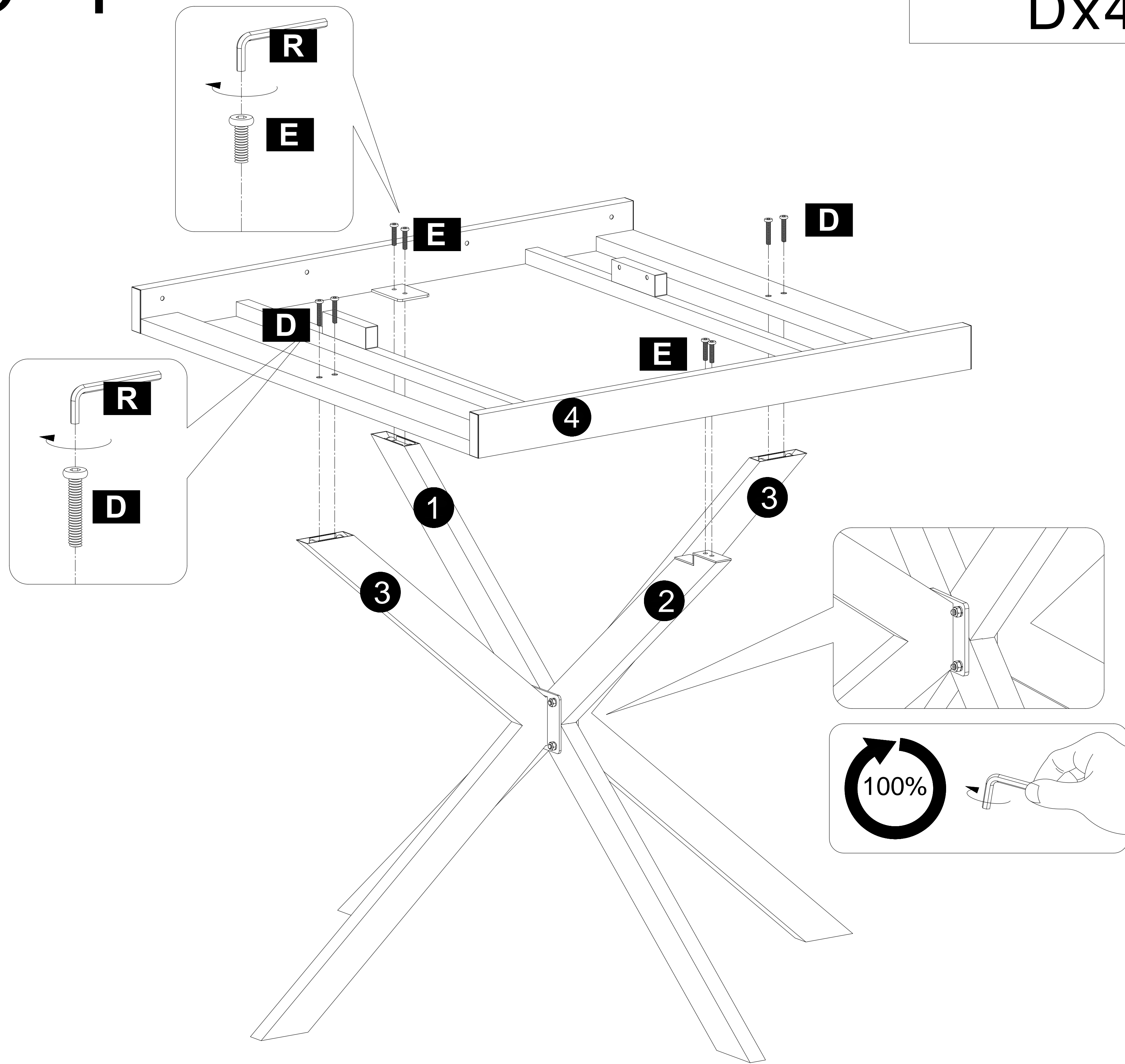

Step 5

YOU WILL NEED
Ax8

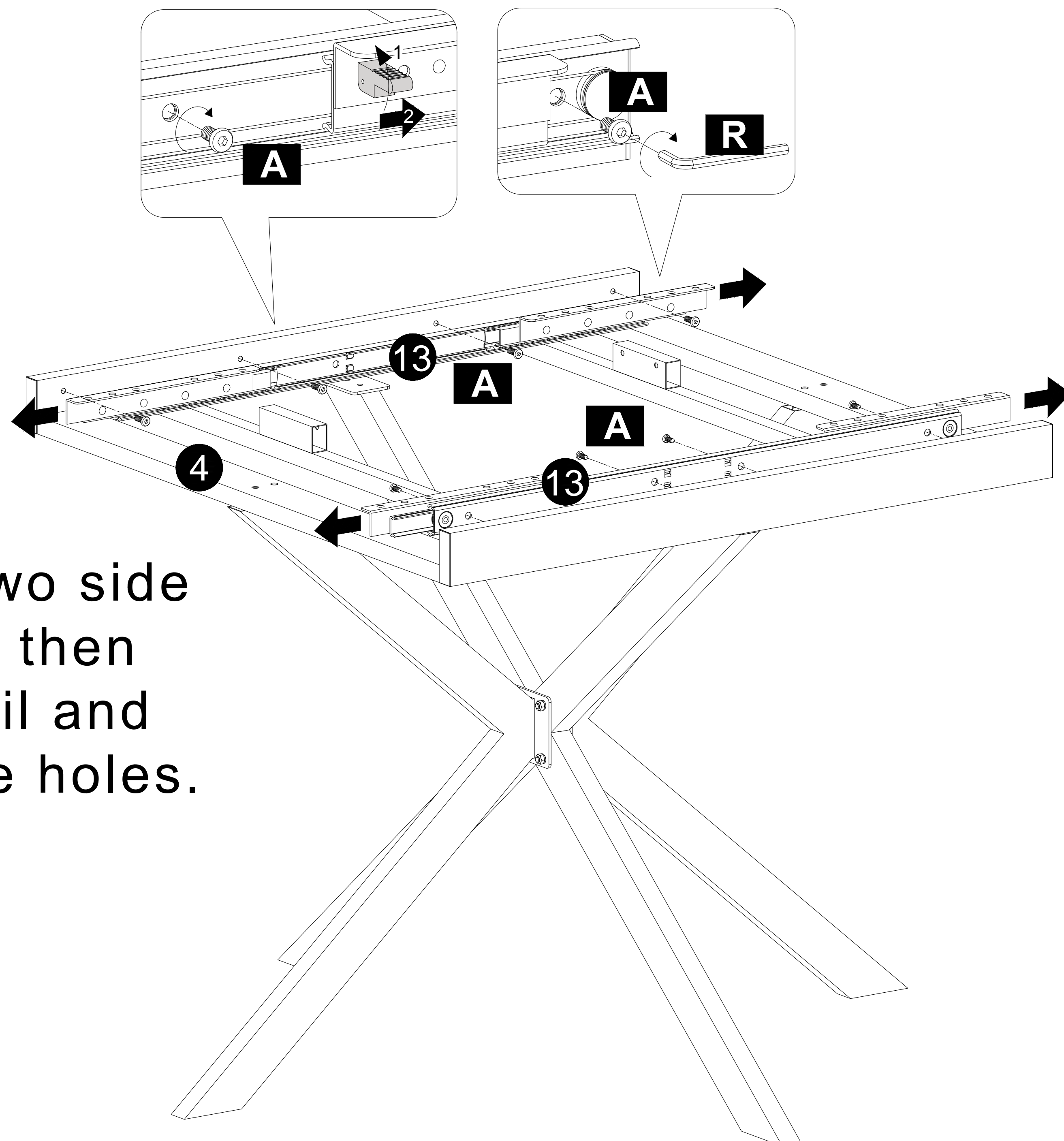

First, secure the two side holes of the rail, then slide open the rail and lock the two middle holes.

Step 6

YOU WILL NEED

Bx4

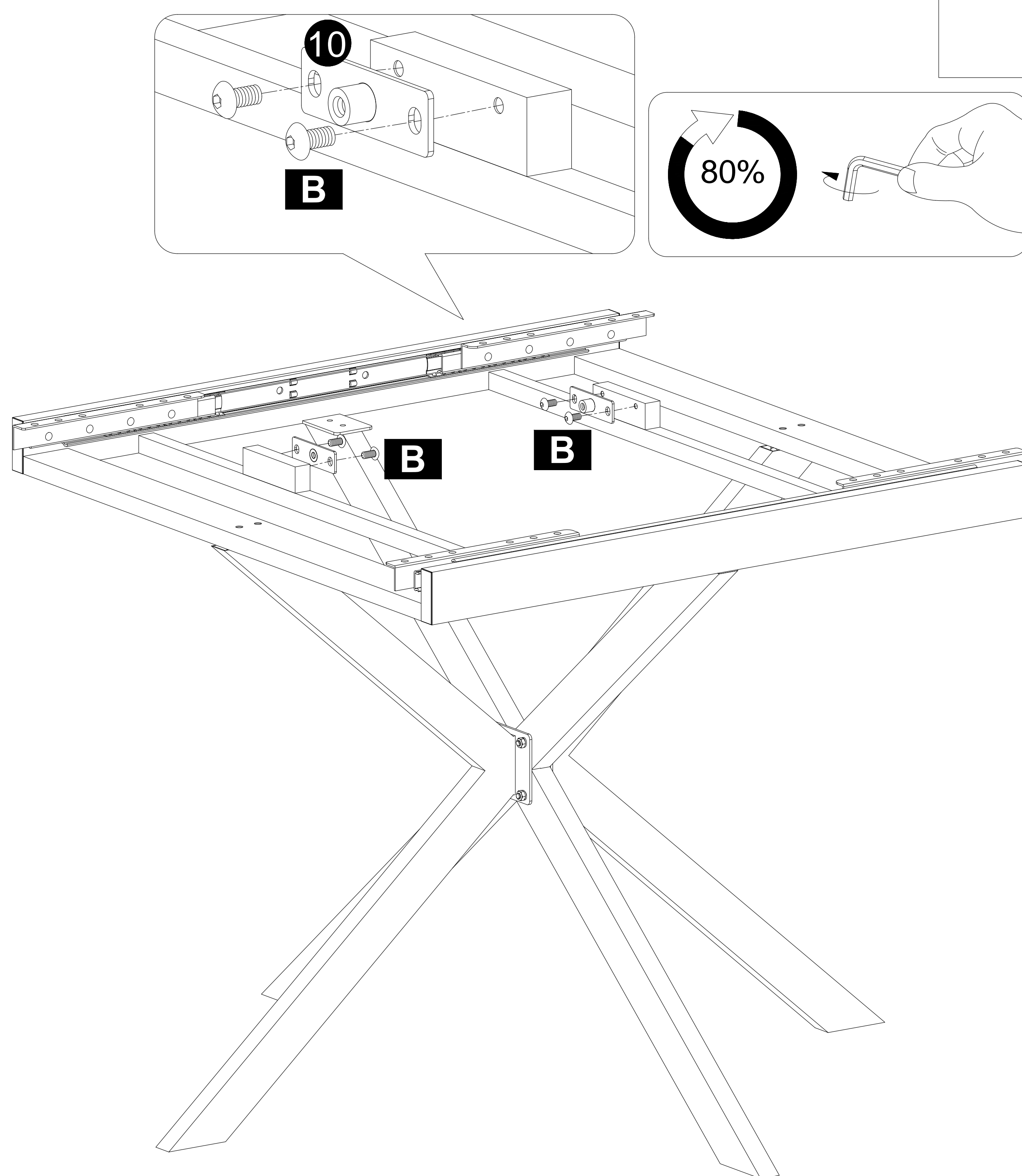

Step 7

YOU WILL NEED

Lx4 / Fx8

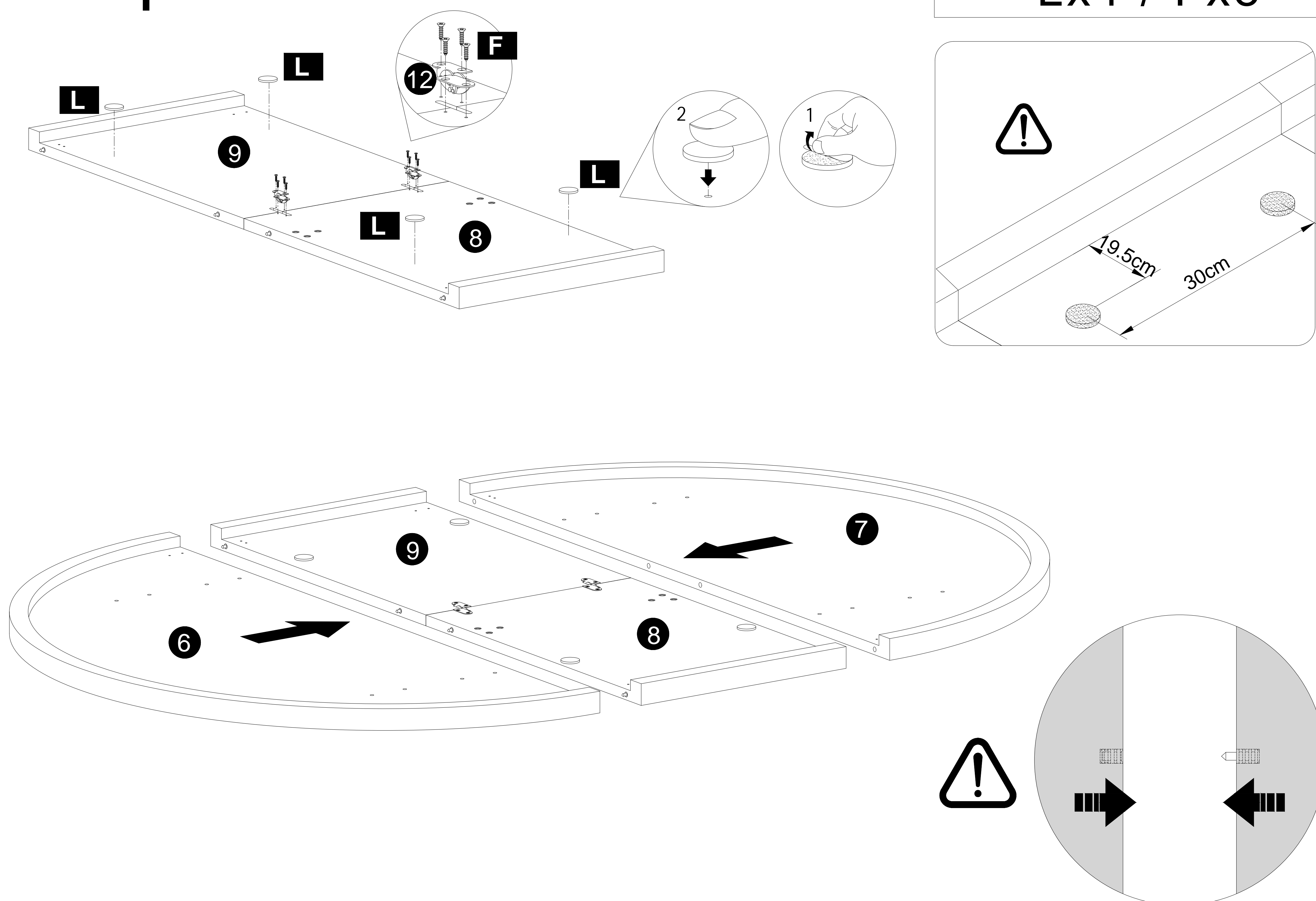

Step 8

YOU WILL NEED
Kx4 / Fx16

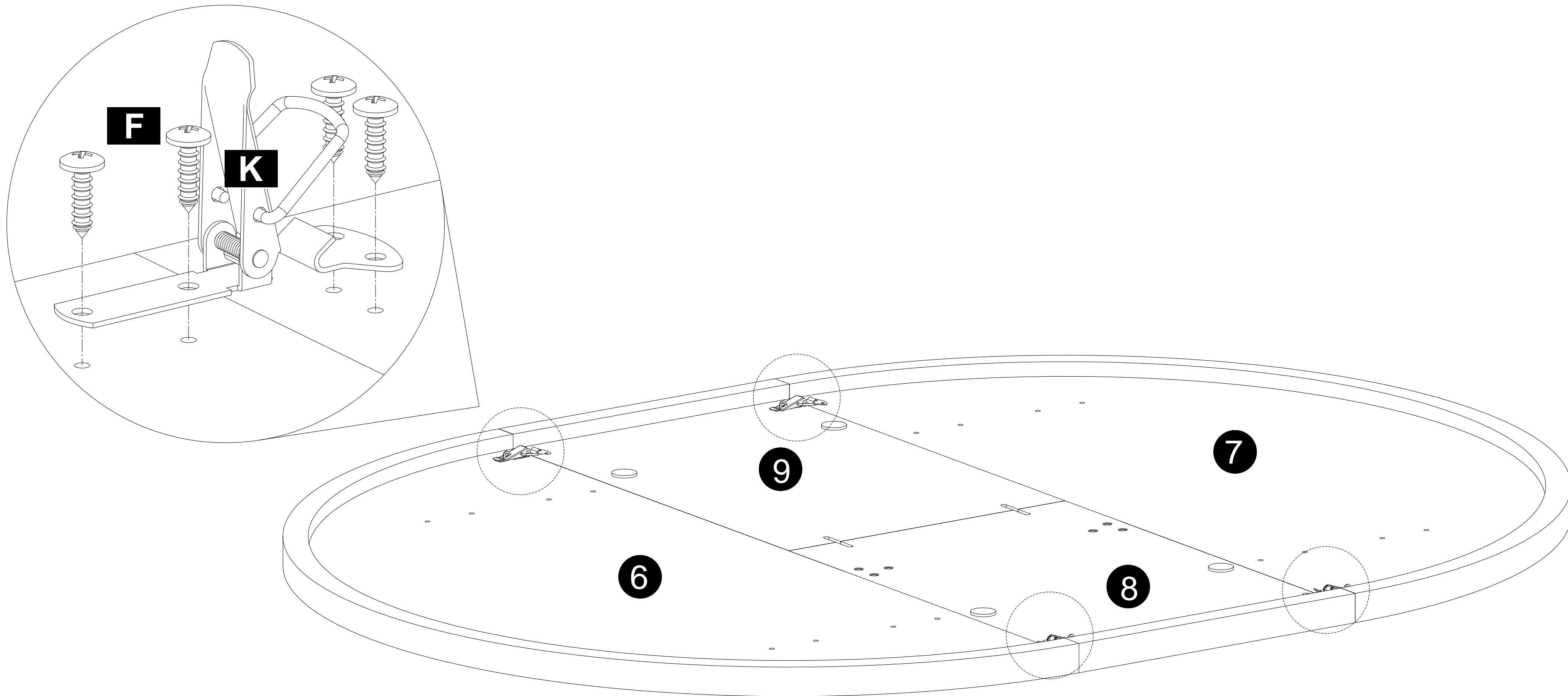

Step 9

YOU WILL NEED
Bx16 / Jx4

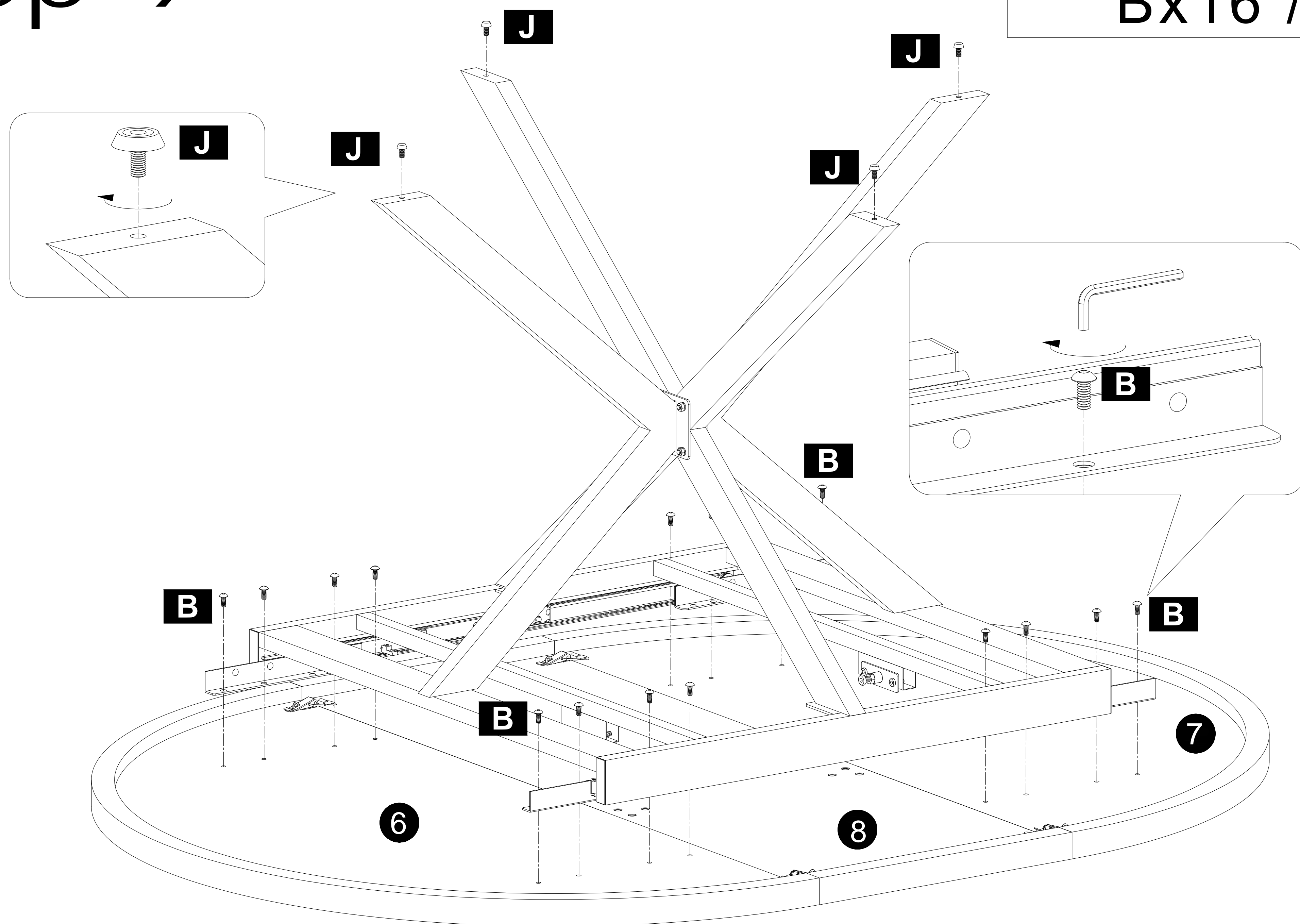

Step 10

YOU WILL NEED
Bx6 / Ox2 / Px2

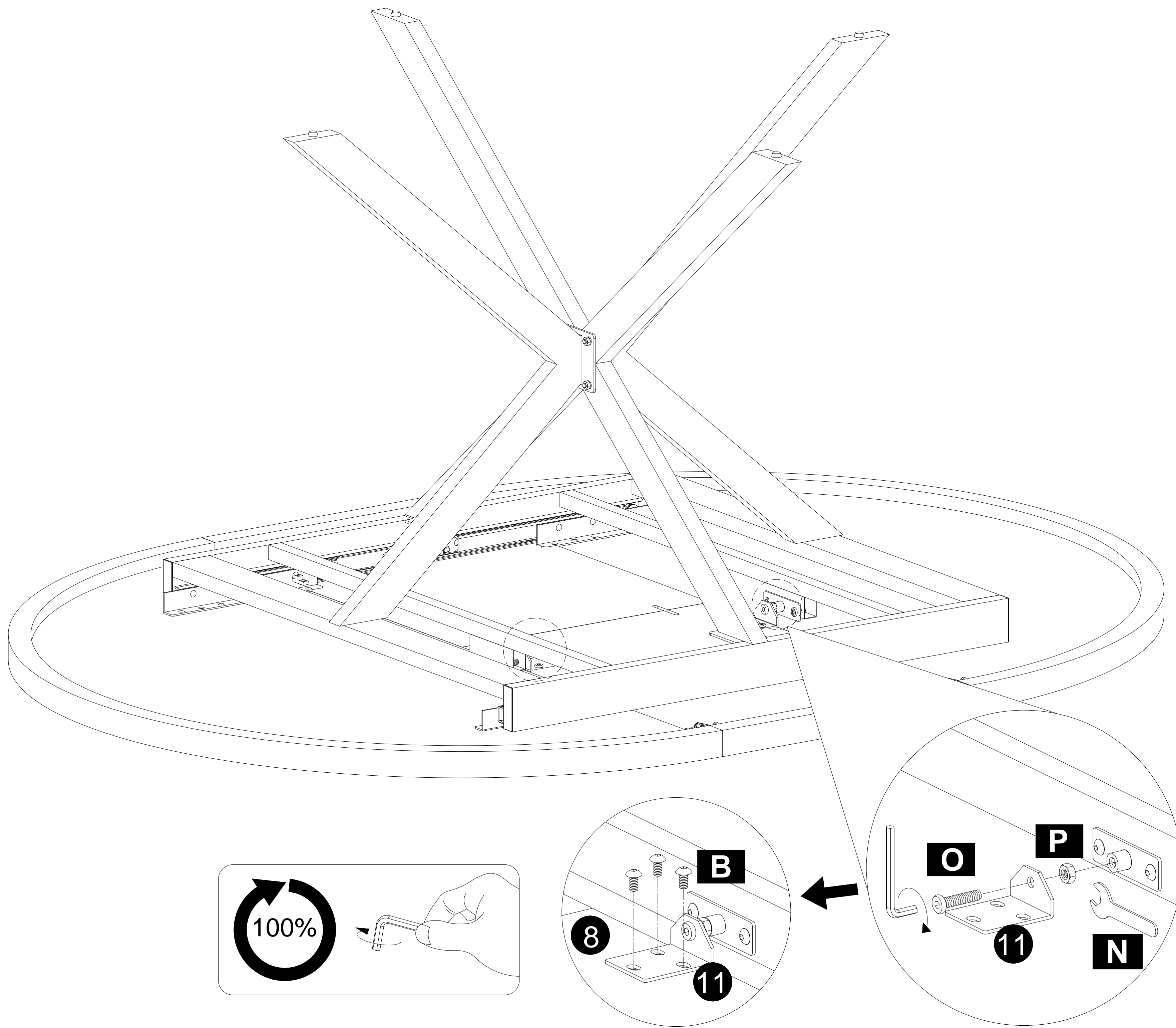

Step 11

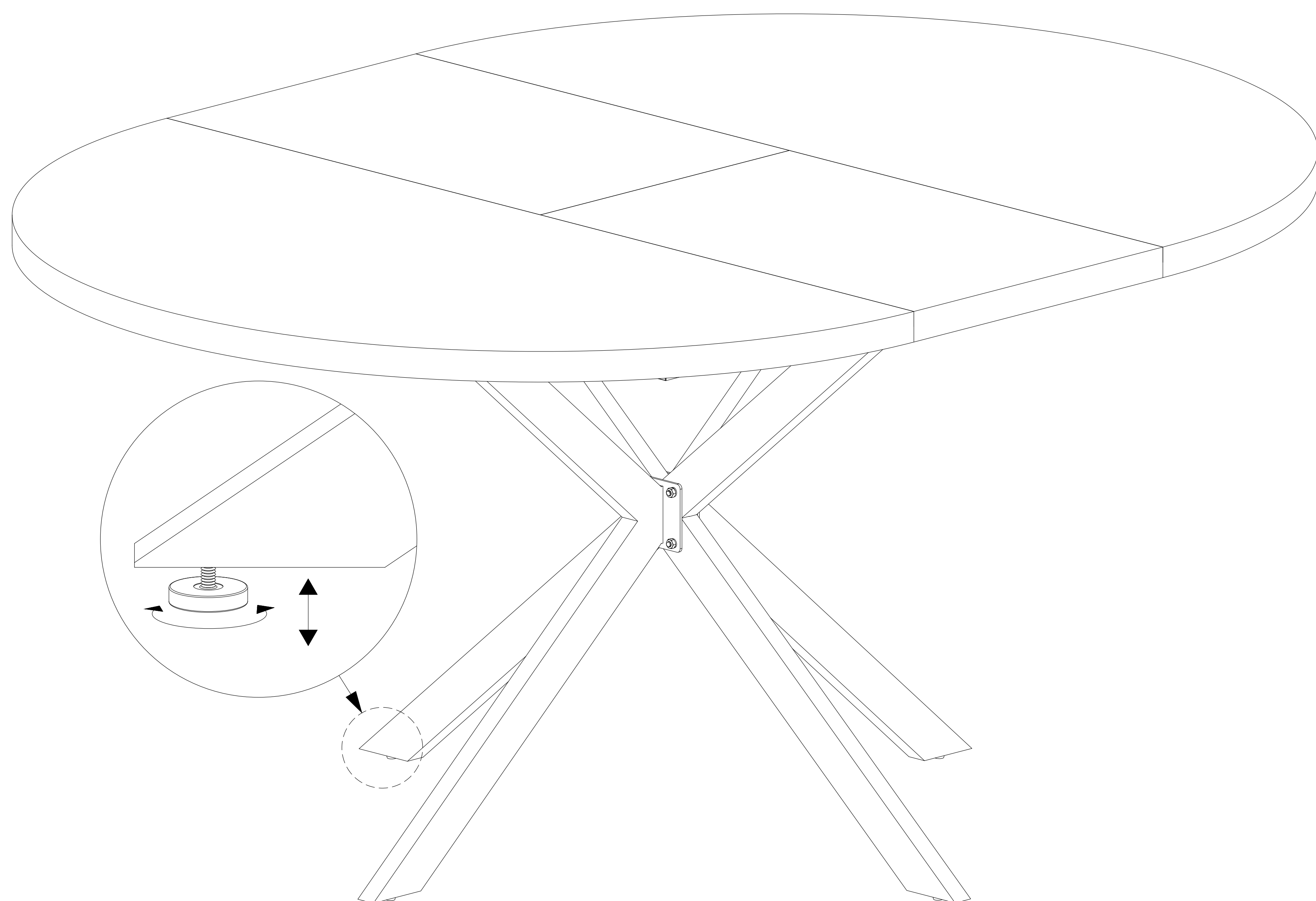

Step 12

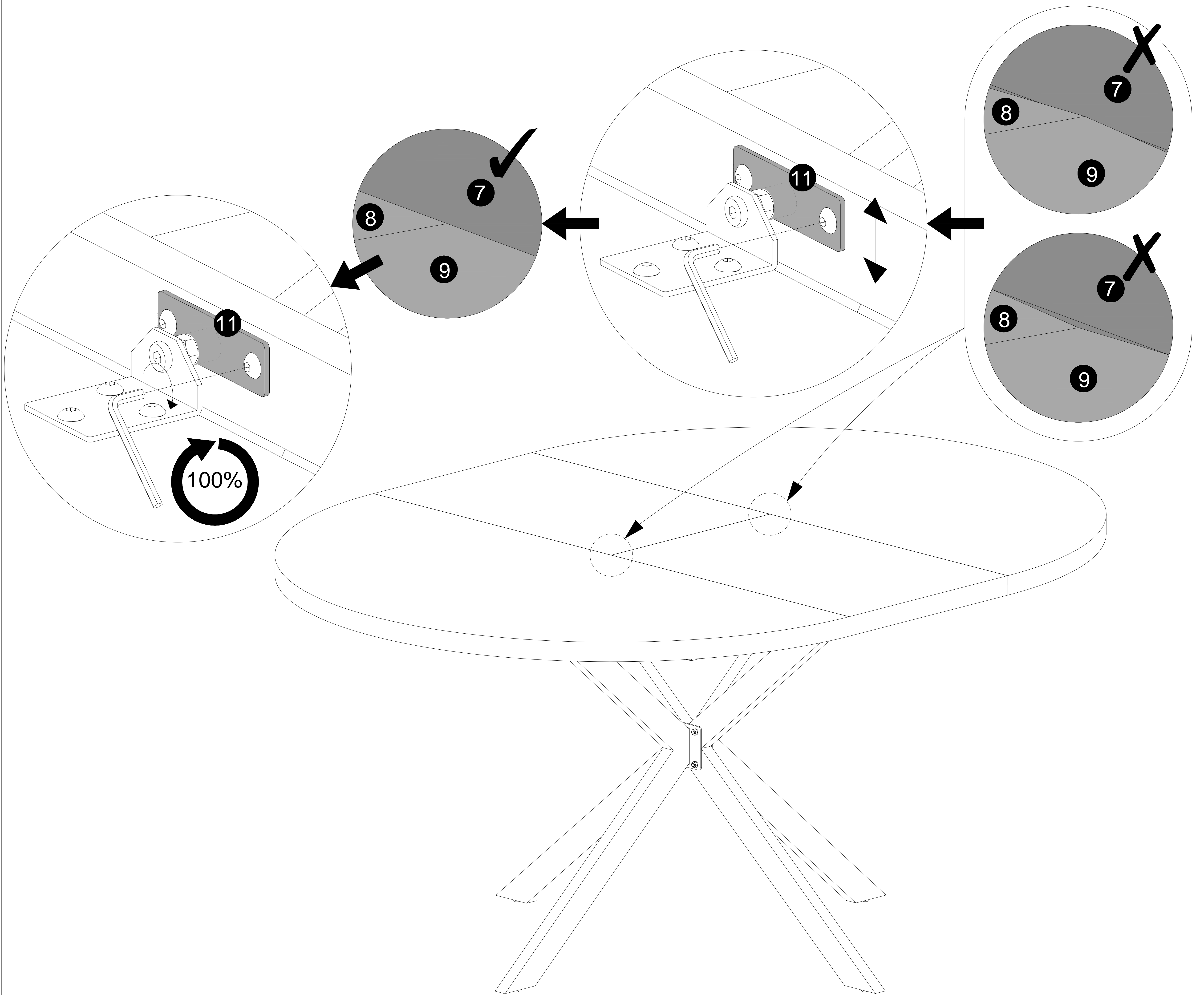

Step 13

