

ASSEMBLY INSTRUCTION

DESCRIPTION: 2577 CORA DRESSING TABLE

1.5 HR

APPROXIMATE ASSEMBLY TIME

2 PERSON ASSEMBLY

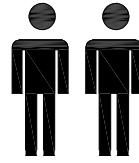

FLOOR AREA
1.8M X 2.2M

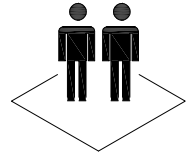

REQUIRED ASSEMBLY SPACE

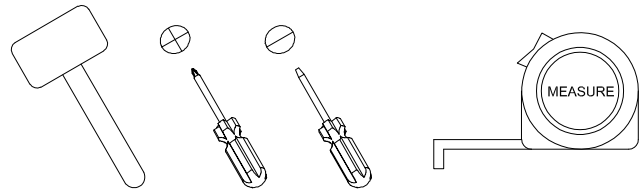

REQUIRED ASSEMBLY TOOLS (NOT PROVIDED)

ASSEMBLED DIMENSION

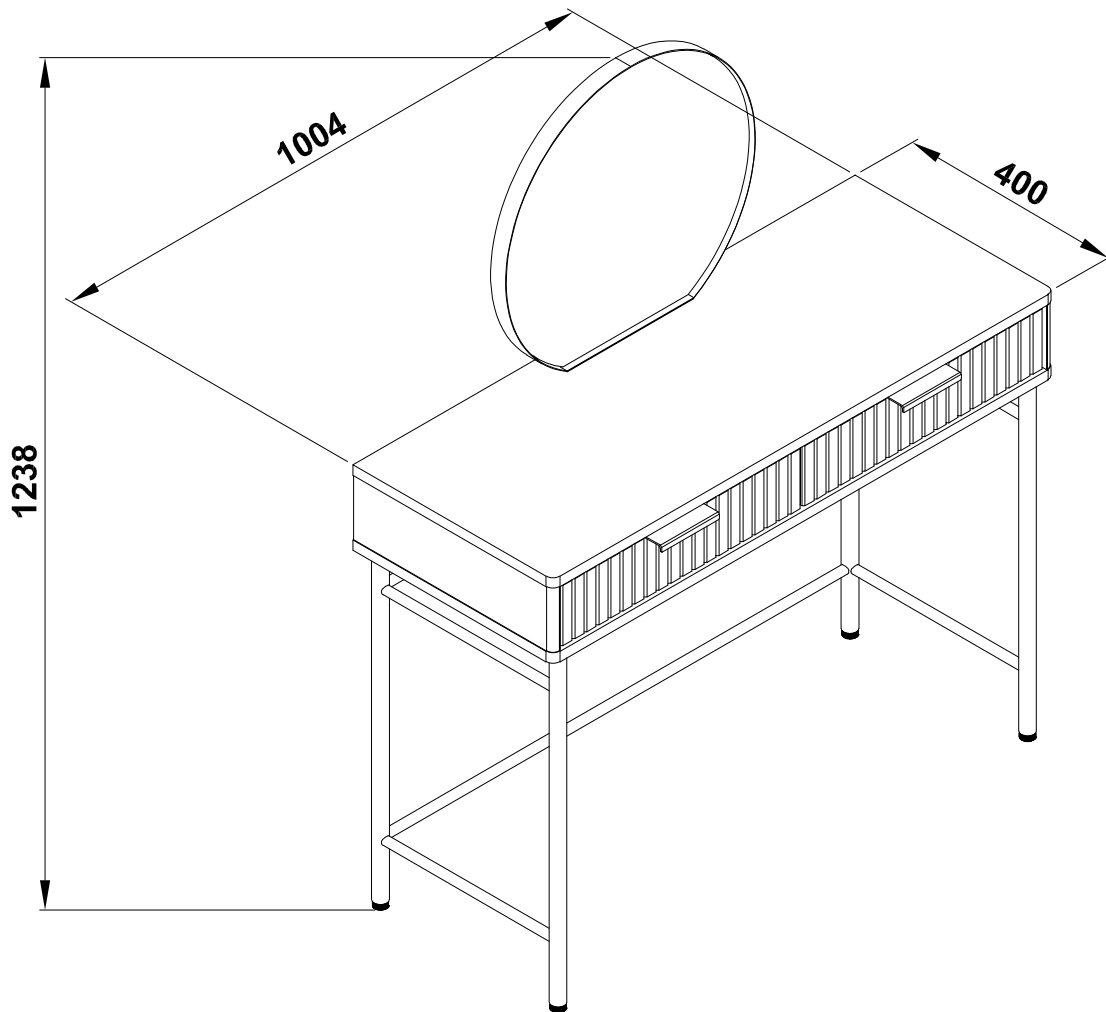

ASSEMBLY INSTRUCTION

DESCRIPTION: 2577 CORA DRESSING TABLE

PART LIST

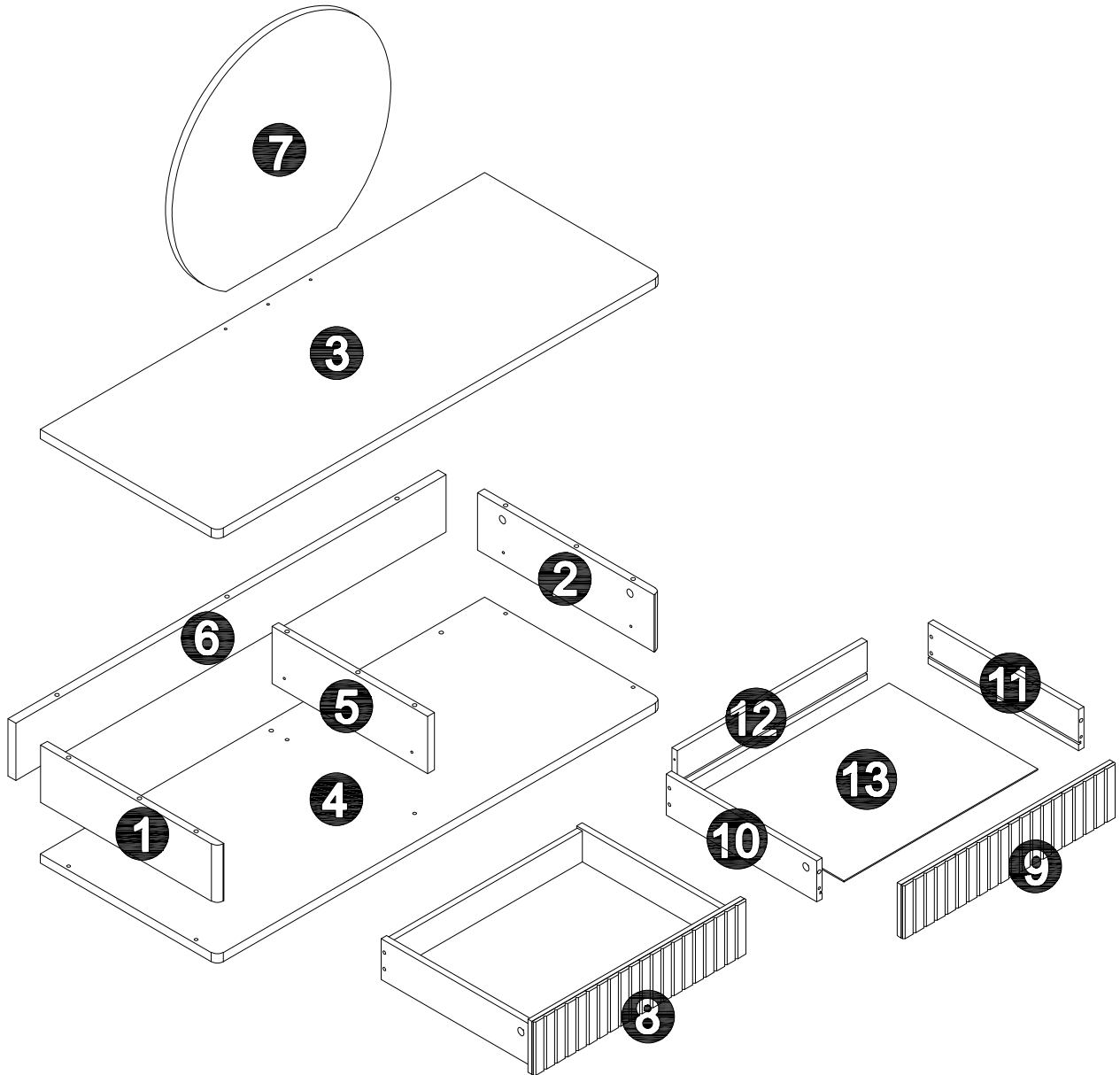







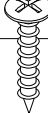

NO.	PART LIST	QTY	NO.	PART LIST	QTY
(1)	PART 1	1	(8)	PART 8	1
(2)	PART 2	1	(9)	PART 9	1
(3)	PART 3	1	(10)	PART 10	2
(4)	PART 4	1	(11)	PART 11	2
(5)	PART 5	1	(12)	PART 12	2
(6)	PART 6	1	(13)	PART 13	2
(7)	PART 7	1			

ASSEMBLY INSTRUCTION

DESCRIPTION: 2577 CORA DRESSING TABLE

HARDWARE LIST

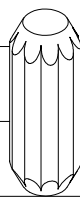
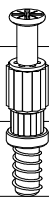
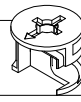
					2 CM
					2 CM
					2 CM
					2 CM
					1 CM
					0 CM
					
X8	X8	X15	X2	X14	
M3.5 X 12MM	M6 X 9MM	M6 X 13MM	M4 X 16MM	M6 X 40MM	
A	B	C	D	E	
SCREW	SCREW	SCREW	SCREW	SCREW	

						3 CM
						2 CM
						1 CM
						0 CM
						
X4	X4	X9	X10	X6	X4	
M6 X 15MM	Ø6 X 20MM	Ø8 X 25MM	20 X 5MM	Ø15 X 12MM	Ø15 X 9MM	
F	G	H	J	K	L	
SCREW	WOOD DOWEL	WOOD DOWEL	BOLT DOWEL	CAM	CAM	

ASSEMBLY INSTRUCTION

DESCRIPTION: 2577 CORA DRESSING TABLE

HARDWARE LIST

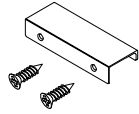

X2 SETS

M

**ALUMINIUM U
SHAPE HANDLE**

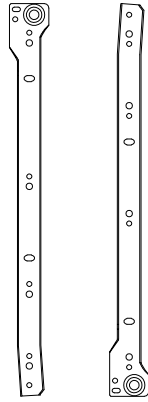

X2 SETS

N1 & N2

**DRAWER SLIDE
(350MM)**

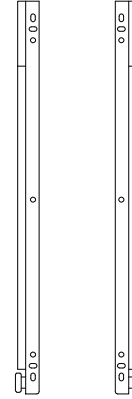

X2 SETS

P1 & P2

**DRAWER SLIDE
(350MM)**

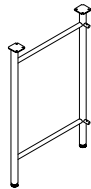

X1

Q

**H SHAPE METAL LEG
(390X620XD25MM) - L**

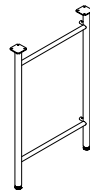

X1

R

**H SHAPE METAL LEG
(390X620XD25MM) - R**

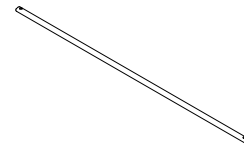

X2

S

**METAL CENTER
ROUND SUPPORT BAR
(D16 X 919)MM**

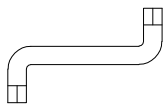

X1

T

ALLEN KEY M4



X2

U

**PP STRAP 12 X 150 X
1.2MM BLK 2 HOLE
WITH EYELEY**

Top Tips before you start!

1. Please check that all parts are present before you start the assembly of your furniture, as once assembled, the furniture is exempt from our home approval policy.
2. For ease and speed of assembly, we recommend that before you commence each step of the assembly, that you identify all the parts required for the step.
3. For larger items, please ensure that you have sufficient space and people (as indicated on page 1) to assemble your product safely.
4. We recommend that, where possible, all items are assembled near to the area in which they will be placed in use, to avoid moving the product unnecessarily once assembled.
5. For the protection of your furniture, particularly items of high gloss finish, we recommend that the product is placed on a protected surface during assembly to prevent any damage.
6. During assembly please take care not to over-tighten any fittings, as this may damage the product.

Care and Maintenance of your Furniture

- Please periodically check all fittings and re-tighten as necessary.
- Please do not drag or pull your furniture.
- Wipe occasionally with a soft cloth slightly dampened with water. Then buff with a dry clean soft cloth.
- Never allow any kind of liquid to remain on your furniture. Absorption can cause wood to warp or finishes to de-laminate.
- Please do not sit or stand on this item.

Special Tips for Fitting Minifix Cam (Cam-Lock), and Minifix Bolt (Cam-Bolts)

CAM-BOLT

Tighten until shoulder is flush with panel. Do not overtighten or undertighten (see example below).

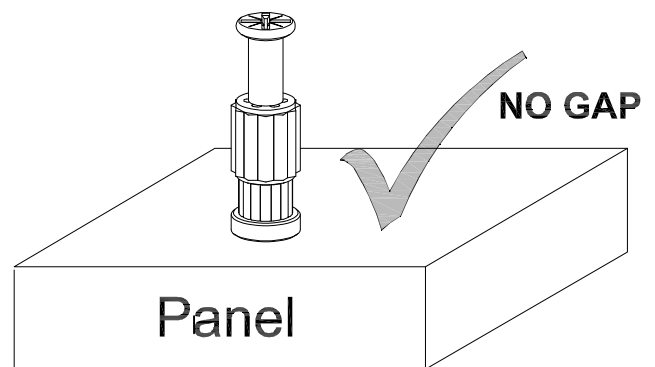
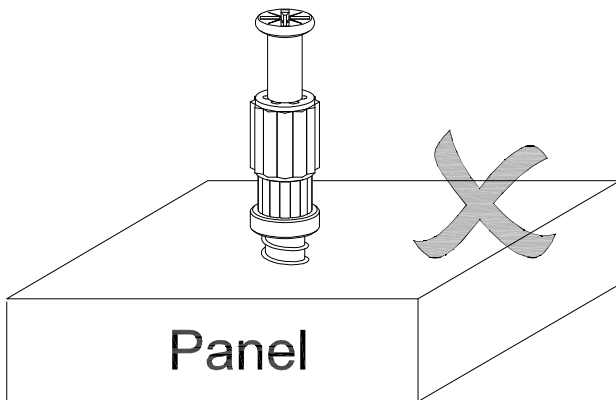
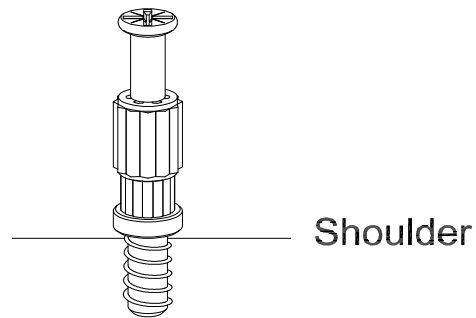

CAM-LOCK

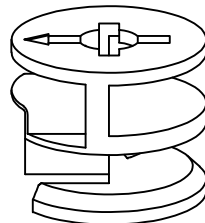

WHEN TIGHTENING CAM-LOCK
Turn The Cam-Lock Clockwise Until
The Arrow Points in The Position as Below !

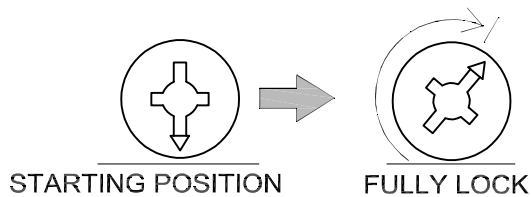

See this Arrow Points !

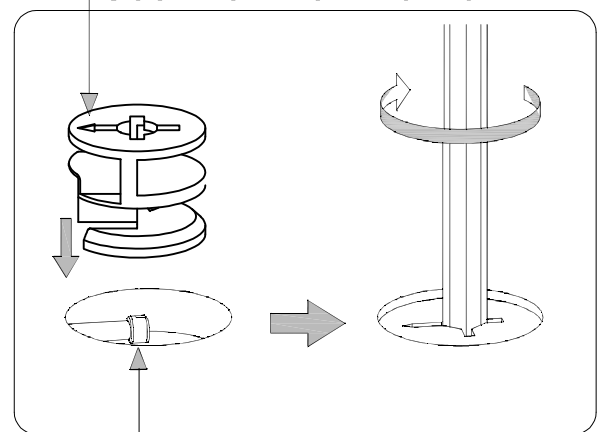

ASSEMBLY INSTRUCTION

DESCRIPTION: 2577 CORA DRESSING TABLE

STEP 1

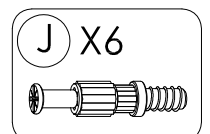
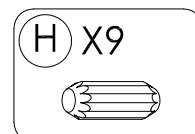
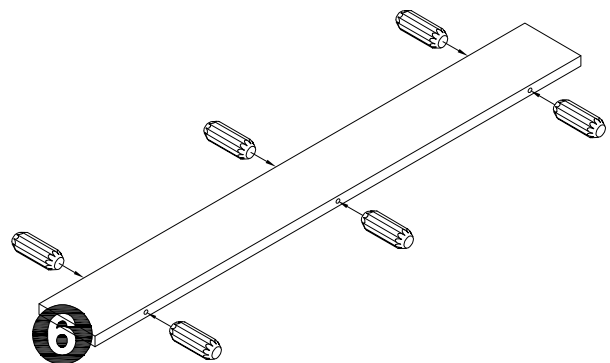
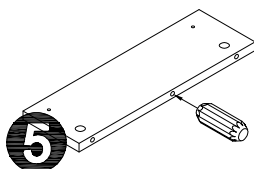
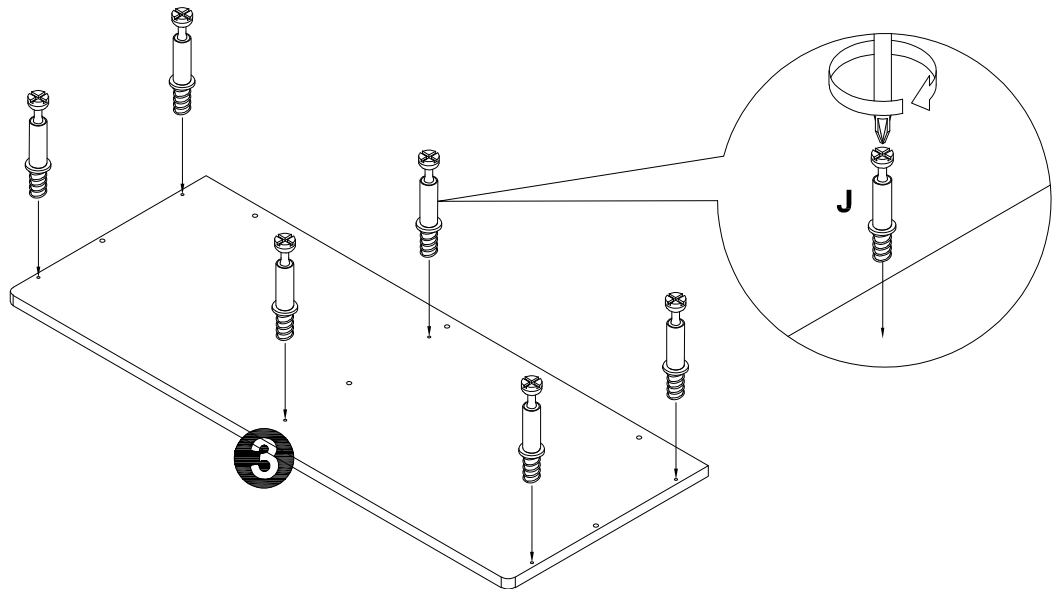
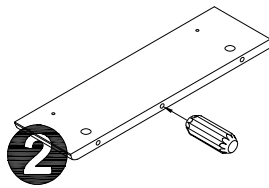
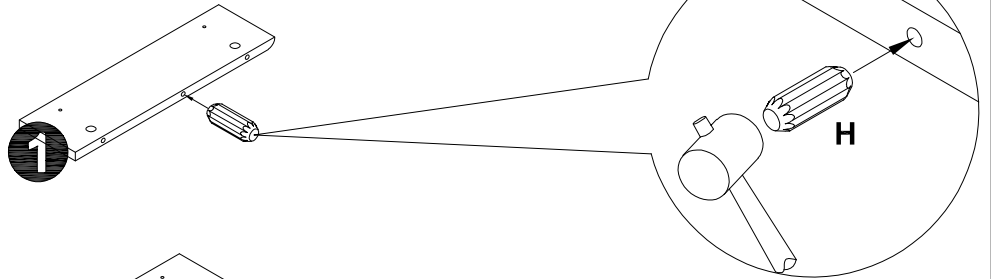

ASSEMBLY INSTRUCTION

DESCRIPTION: 2577 CORA DRESSING TABLE

STEP 2

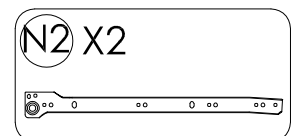
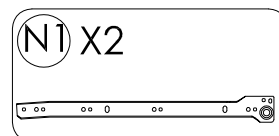
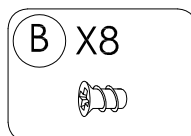
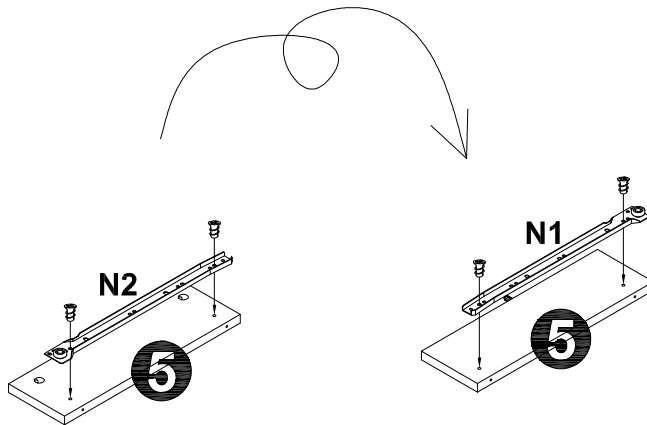
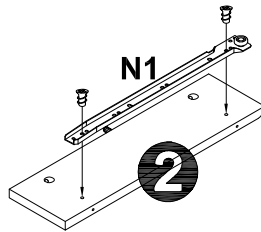
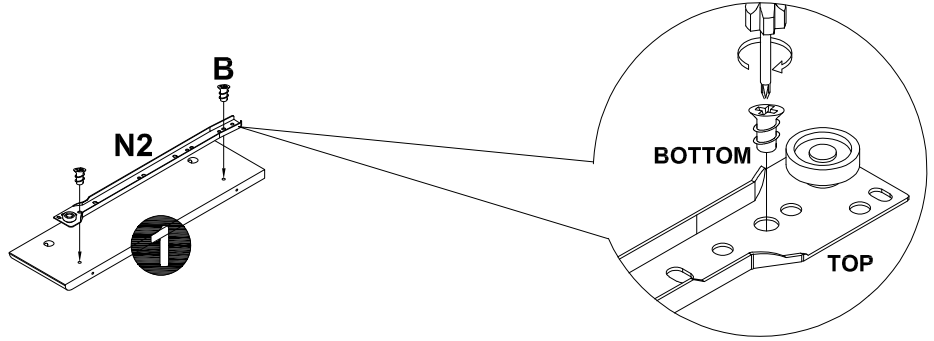
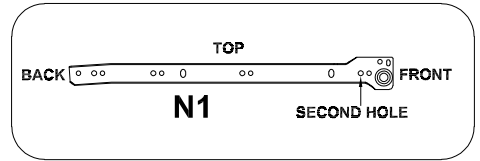

ASSEMBLY INSTRUCTION

DESCRIPTION: 2577 CORA DRESSING TABLE

STEP 3

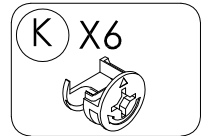
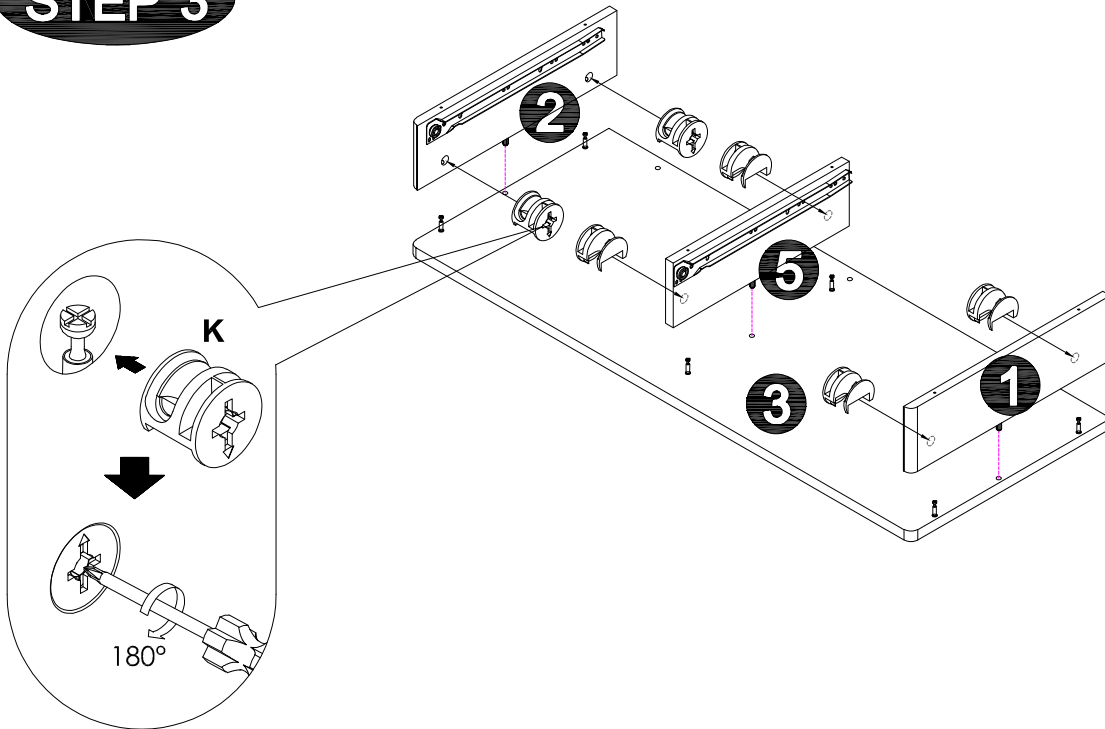

STEP 4

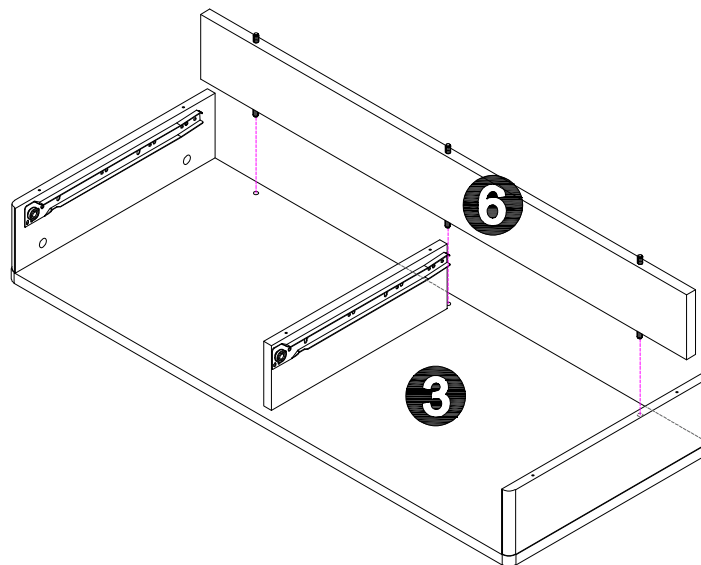

ASSEMBLY INSTRUCTION

DESCRIPTION: 2577 CORA DRESSING TABLE

STEP 5

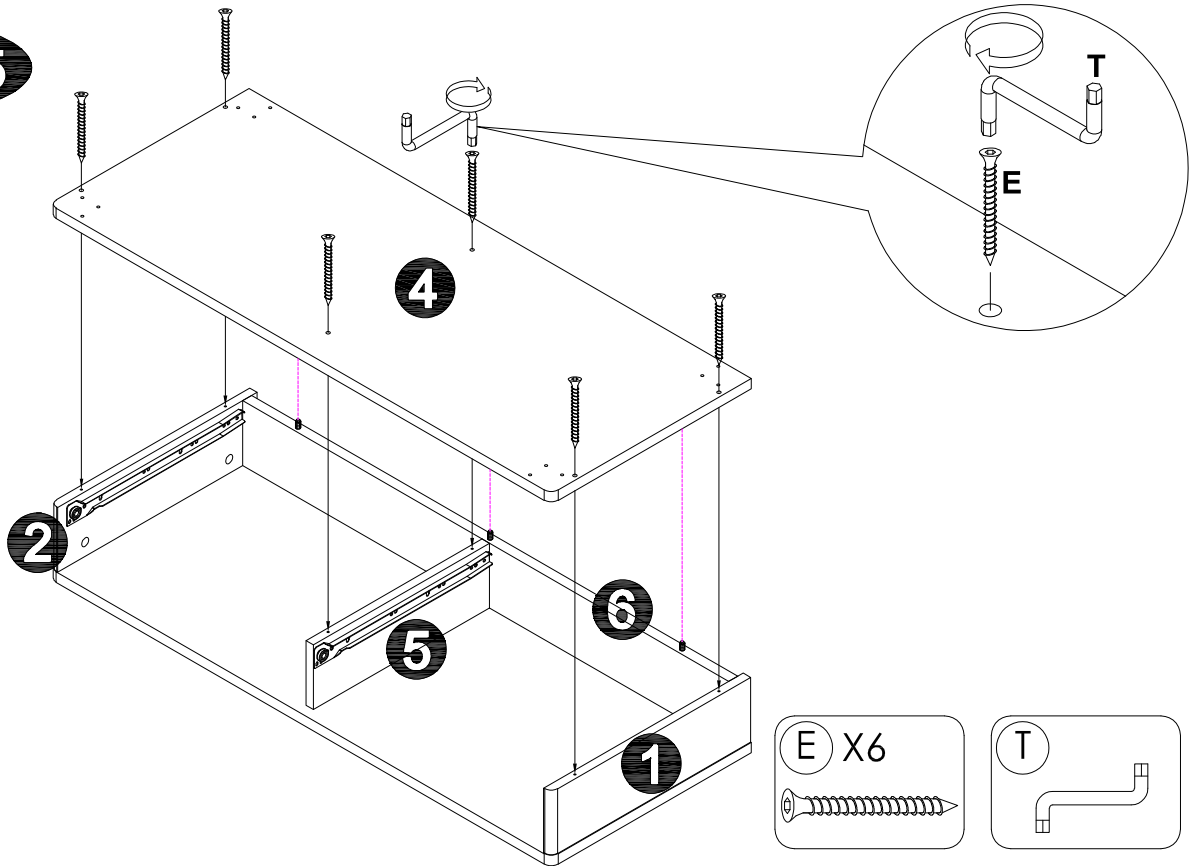

STEP 6

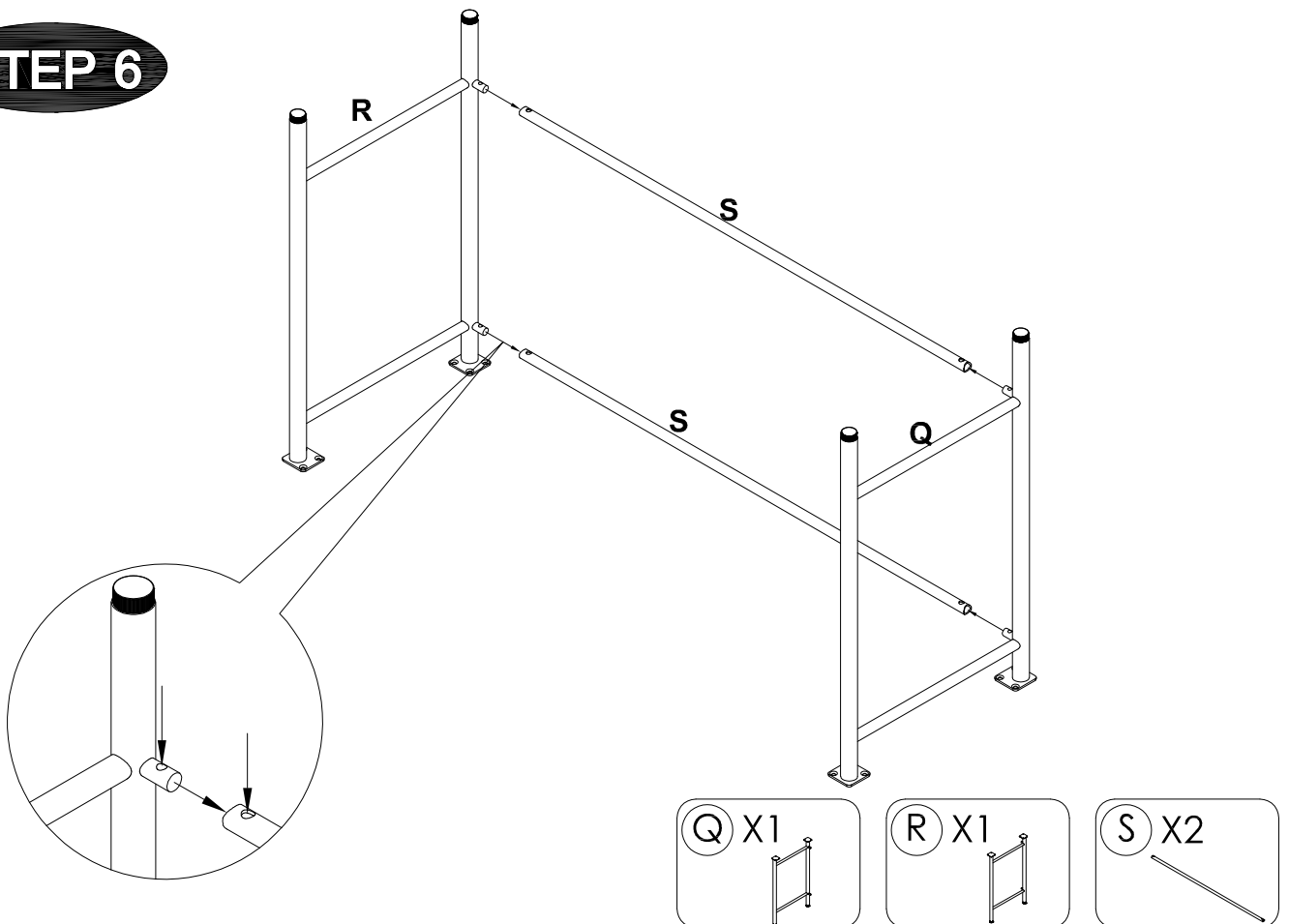

ASSEMBLY INSTRUCTION

DESCRIPTION: 2577 CORA DRESSING TABLE

STEP 7

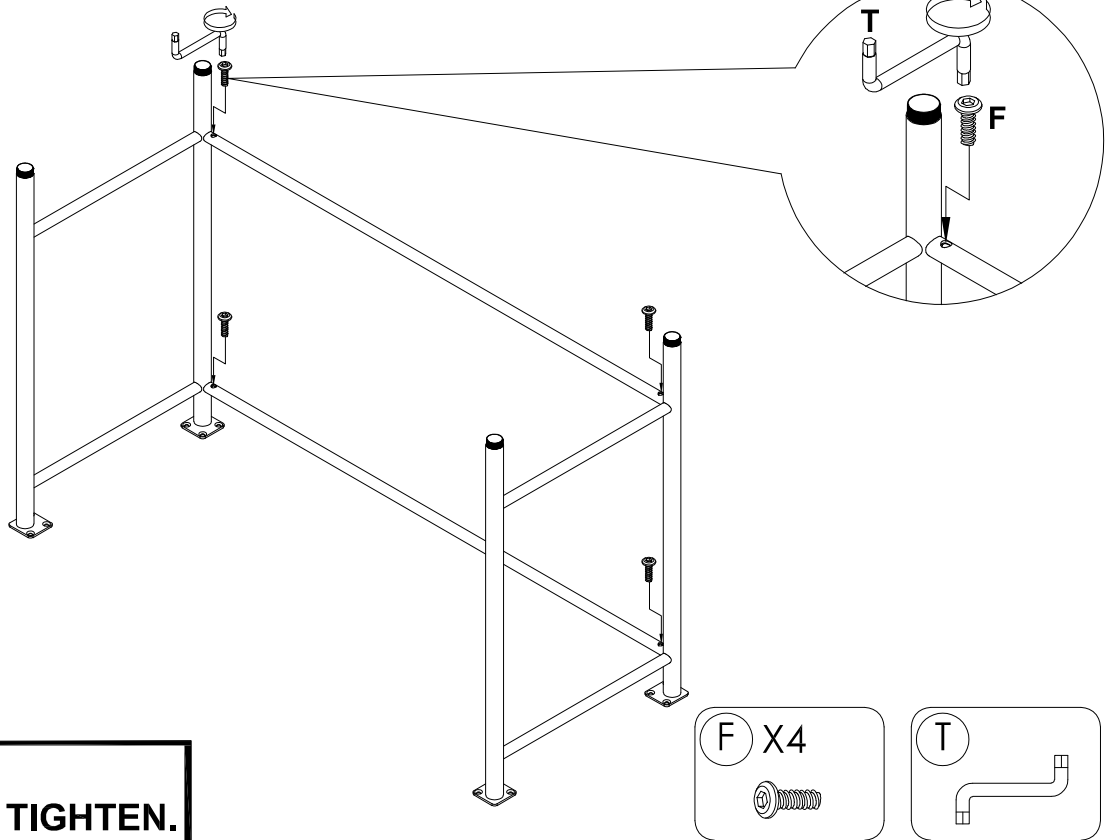

NOTE :
DO NOT FULLY TIGHTEN.

STEP 8

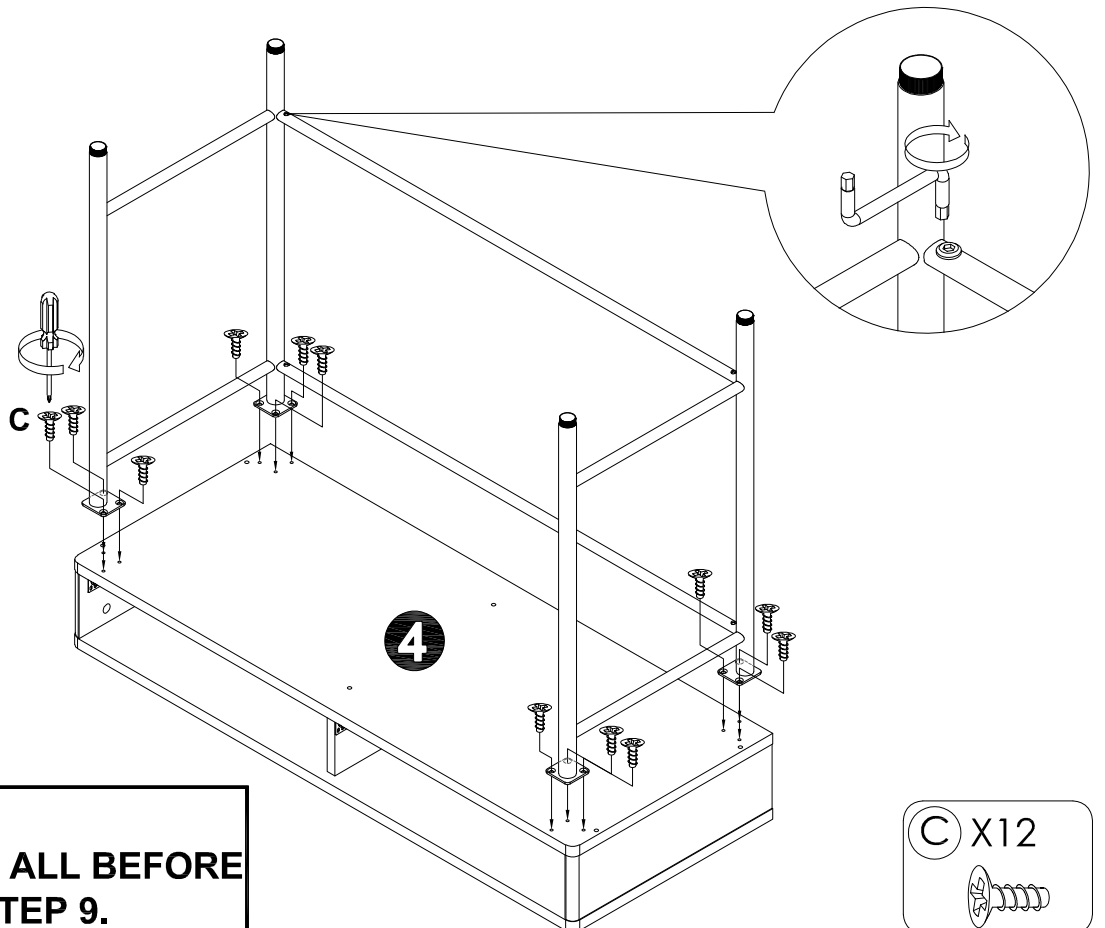

NOTE :
**FULLY TIGHTEN ALL BEFORE
CONTINUE TO STEP 9.**

ASSEMBLY INSTRUCTION

DESCRIPTION: 2577 CORA DRESSING TABLE

STEP 9

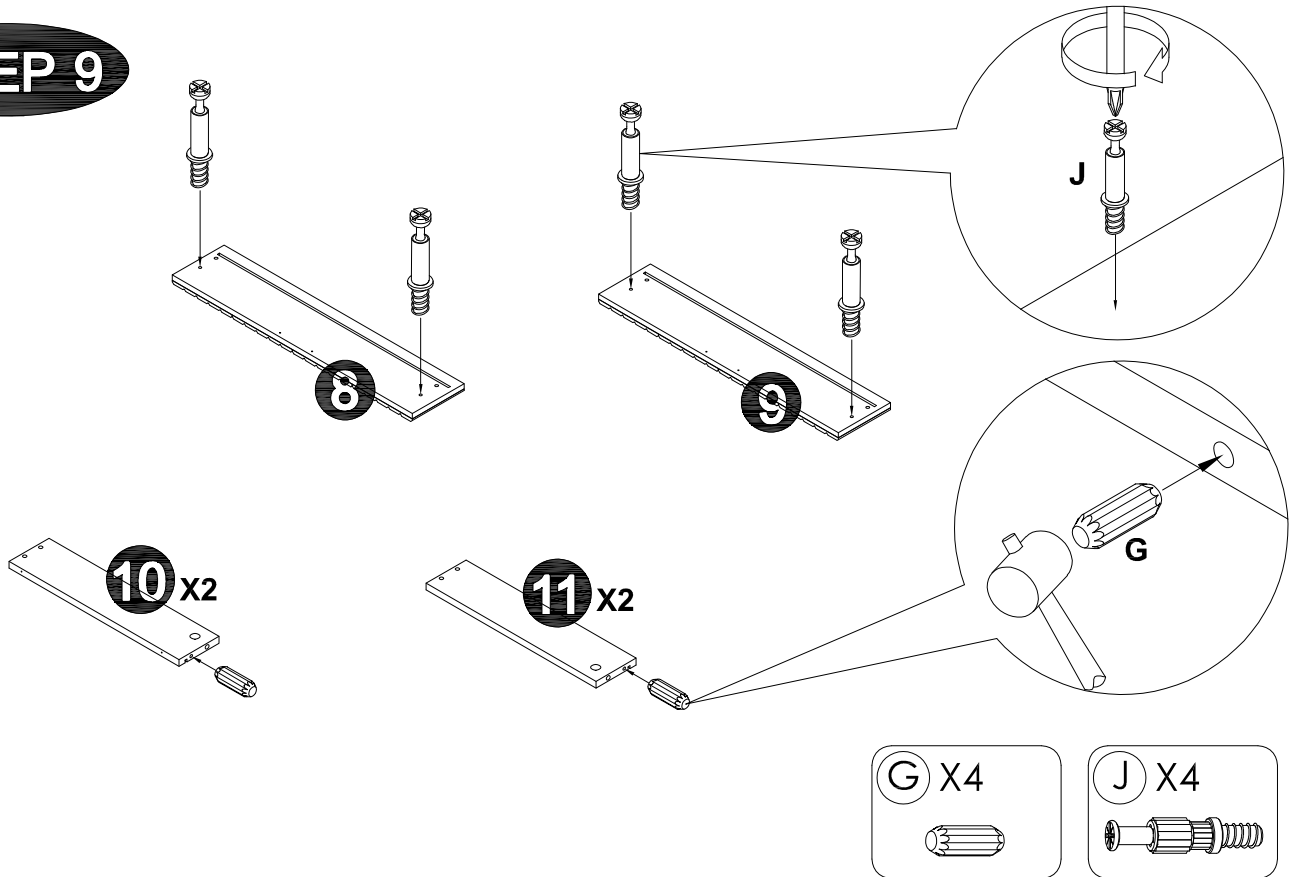

STEP 10

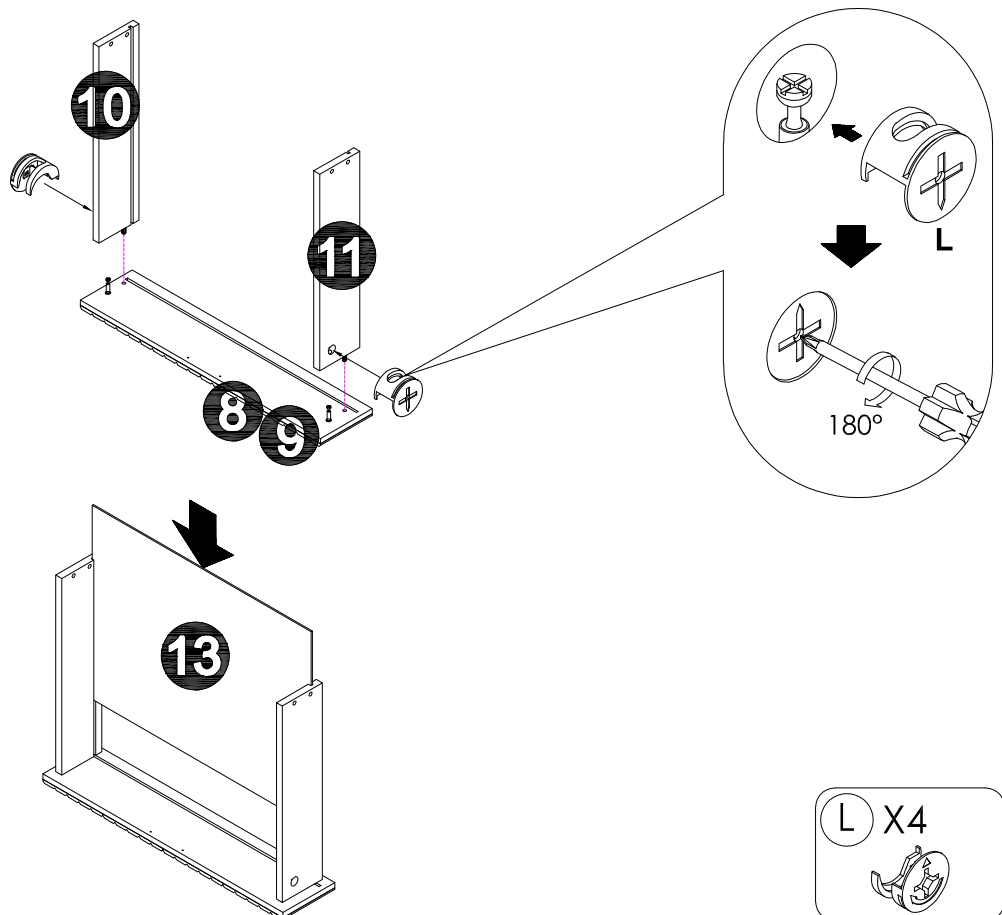

X2

**ASSEMBLY
INSTRUCTION**

**DESCRIPTION:
2577
CORA DRESSING TABLE**

STEP 11

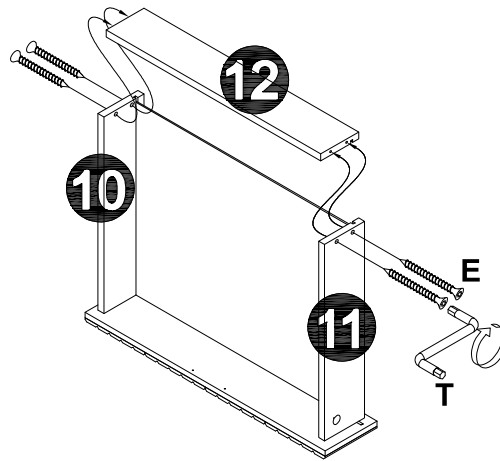

X2

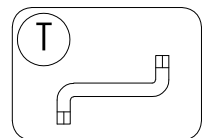
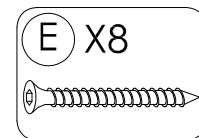

STEP 12

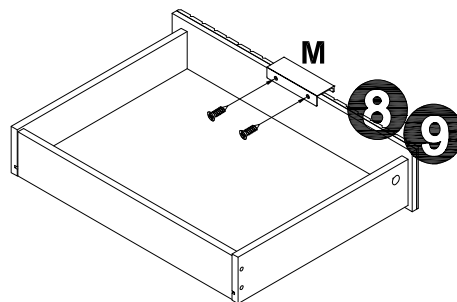

X2

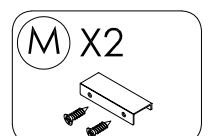

**ASSEMBLY
INSTRUCTION**

**DESCRIPTION:
2577
CORA DRESSING TABLE**

STEP 13

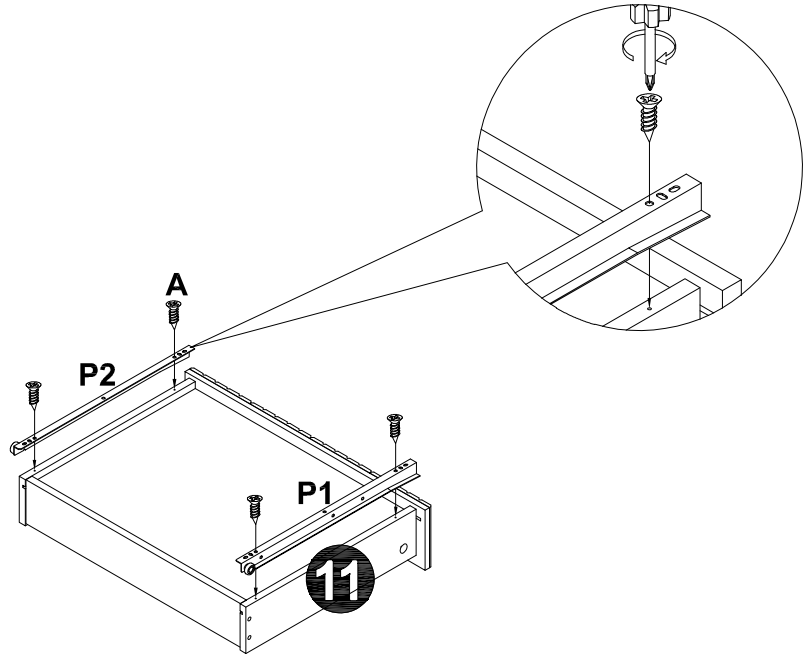

X2

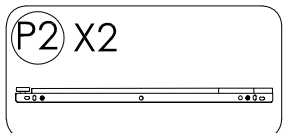
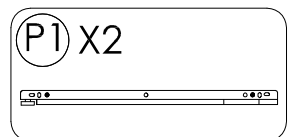
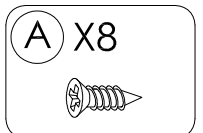
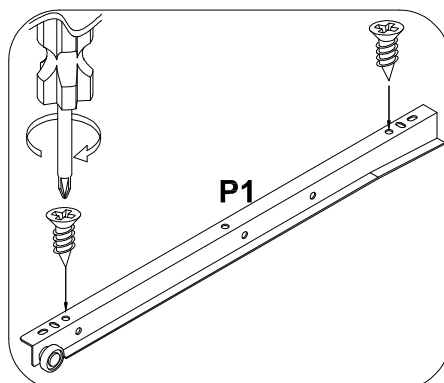
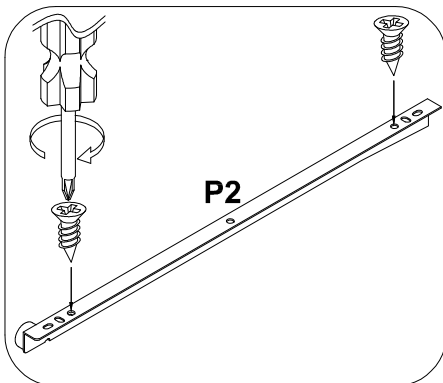

**ASSEMBLY
INSTRUCTION**

**DESCRIPTION:
2577
CORA DRESSING TABLE**

STEP 14

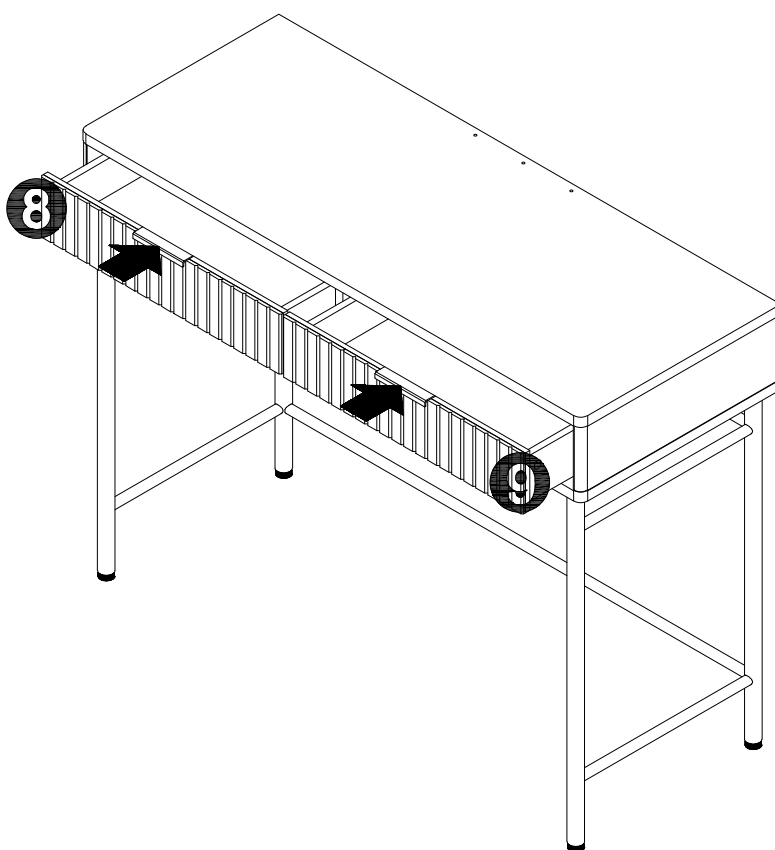

**ASSEMBLY
INSTRUCTION**

**DESCRIPTION:
2577
CORA DRESSING TABLE**

STEP 15

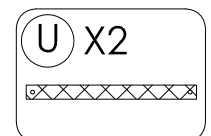
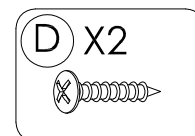
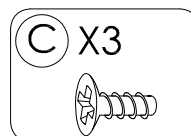
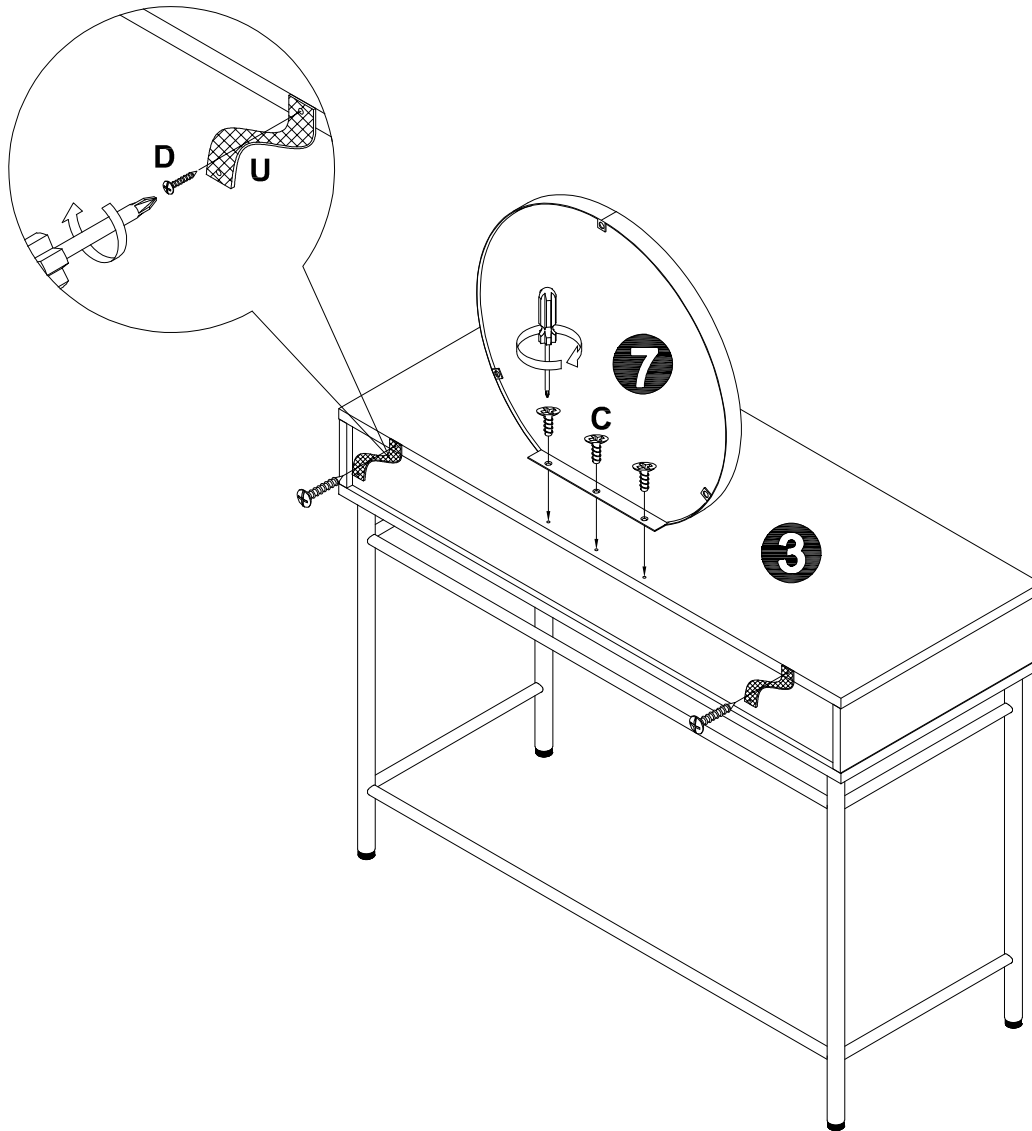

ASSEMBLY INSTRUCTION

DESCRIPTION: 2577 CORA DRESSING TABLE

STEP 16

NOTE :
WALL PLUG & SCREW ARE
NOT SUPPLIED WITH THIS
PRODUCT AS DIFFERENT WALL
MATERIALS REQUIRE DIFFERENT
TYPES OF FIXING HARDWARE &
YOU MUST USE SUITABLE FIXING
HARDWARE FOR TYPE OF WALL
YOU INTEND TO MOUNT THIS
PRODUCT TO WALL.

WALL

