

**ASSEMBLY
INSTRUCTION**

**DESCRIPTION:
8323**

45 MINS

APPROXIMATE ASSEMBLY TIME

1 PERSON ASSEMBLY



FLOOR AREA
1.2M X 1.7M

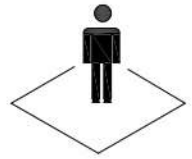

REQUIRED ASSEMBLY SPACE

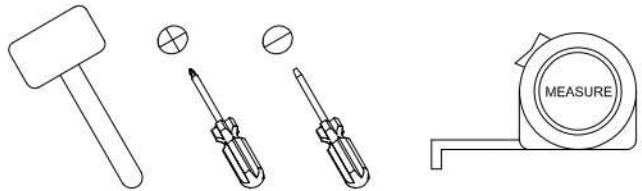

REQUIRED ASSEMBLY TOOLS (NOT PROVIDED)

ASSEMBLED DIMENSION

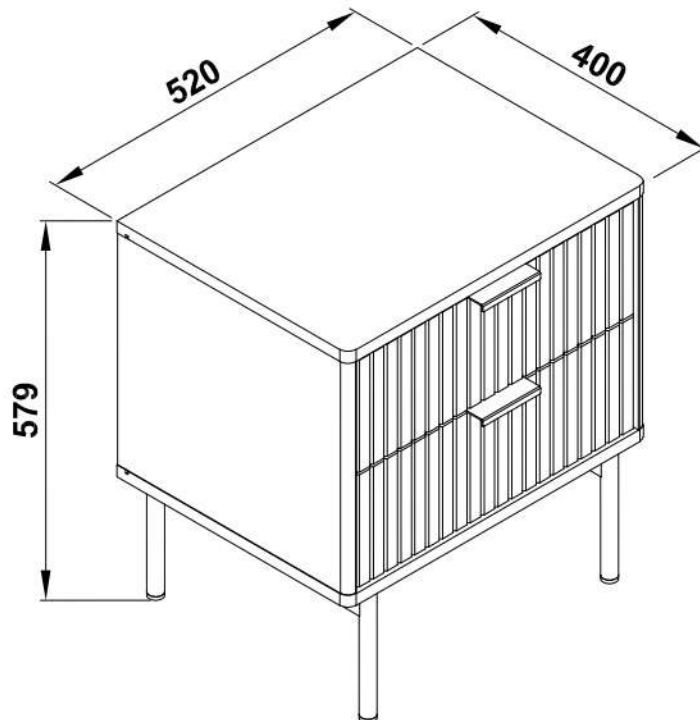

ASSEMBLY INSTRUCTION

DESCRIPTION: 8323

PART LIST

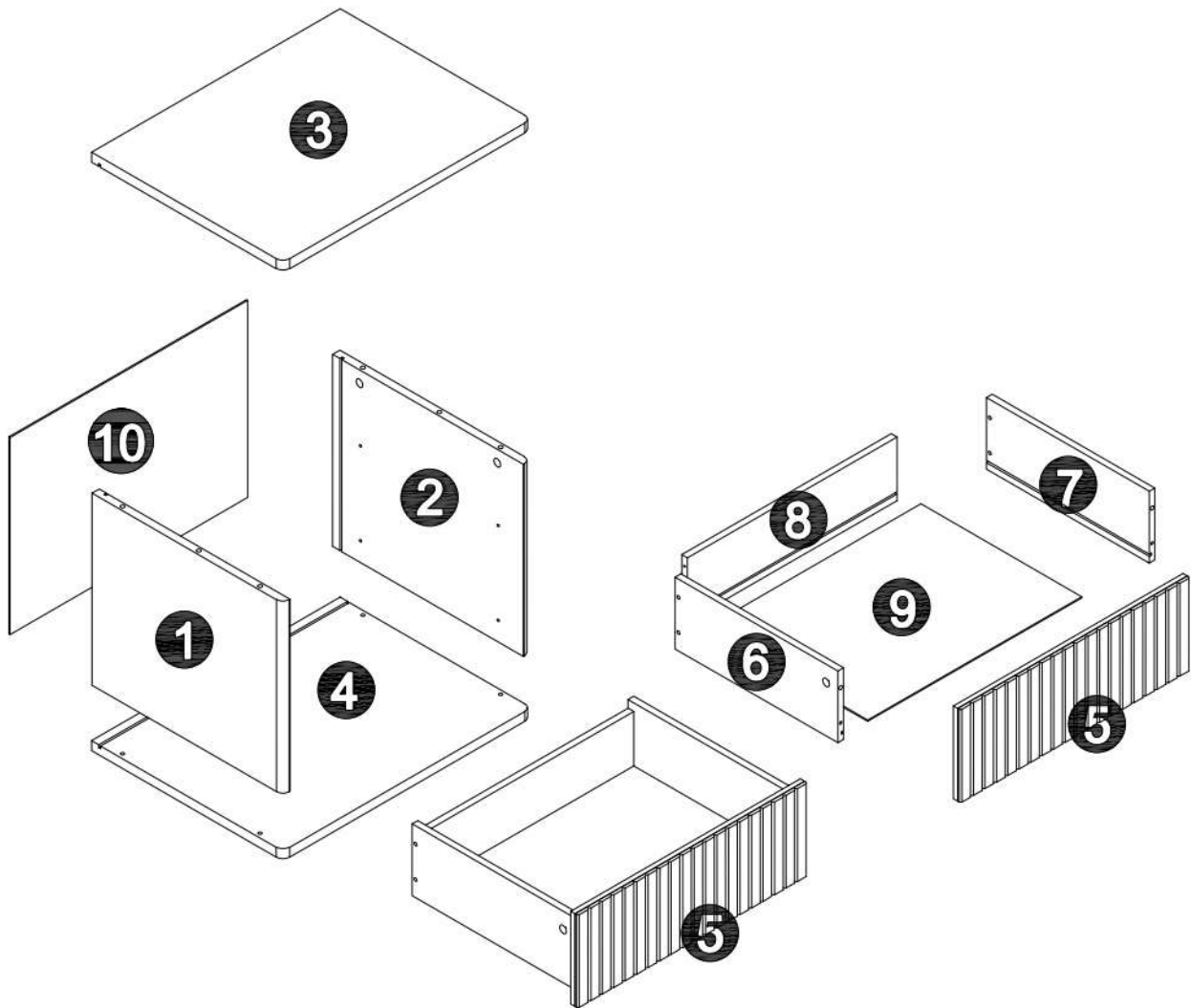





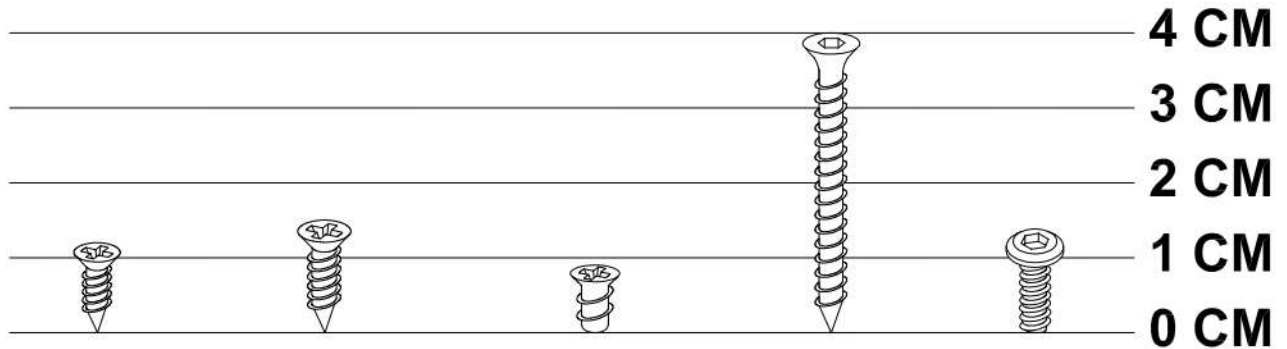

| NO. | PART LIST | QTY | NO. | PART LIST | QTY |
|-----|-----------|-----|------|-----------|-----|
| (1) | PART 1 | 1 | (6) | PART 6 | 2 |
| (2) | PART 2 | 1 | (7) | PART 7 | 2 |
| (3) | PART 3 | 1 | (8) | PART 8 | 2 |
| (4) | PART 4 | 1 | (9) | PART 9 | 2 |
| (5) | PART 5 | 2 | (10) | PART 10 | 1 |

ASSEMBLY INSTRUCTION





DESCRIPTION: 8323

HARDWARE LIST

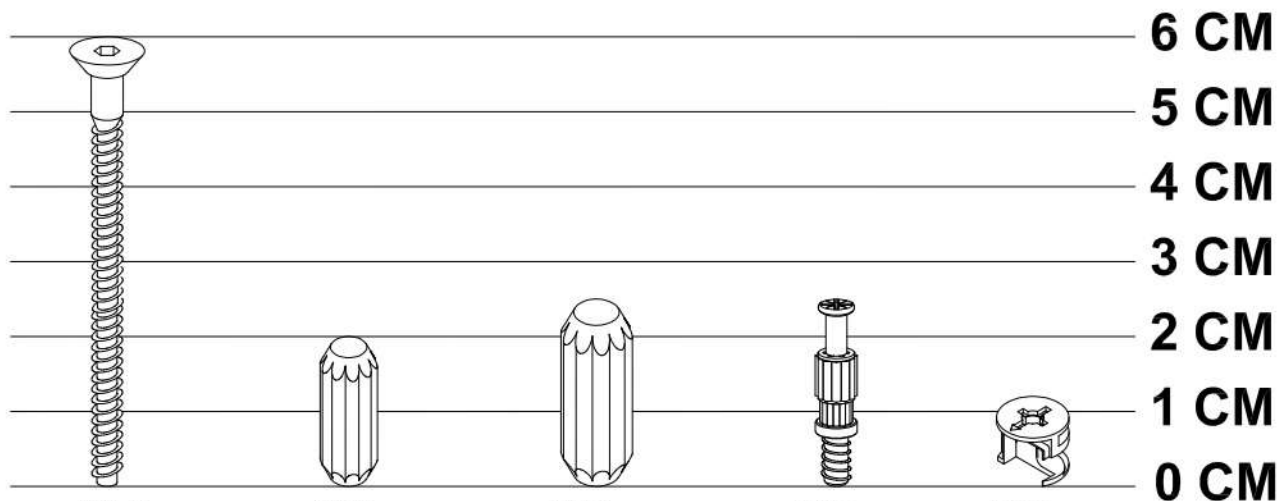

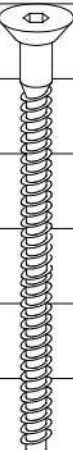
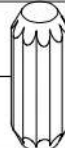
| | | | | |
|---|---|---|--|---|
|  |  |  |  |  |
| X8 | X4 | X8 | X12 | X2 |
| M3.5 X 12MM | M3.5 X 15MM | M6 X 9MM | M6 X 40MM | M6 X 15MM |
| A | B | C | D | E |
| SCREW | SCREW | SCREW | SCREW | SCREW |



| | | | | |
|---|---|---|--|---|
|  |  |  |  |  |
| X4 | X4 | X2 | X8 | X4 |
| M7 X 60MM | Ø6 X 20MM | Ø8 X 25MM | 20 X 5MM | Ø15 X 12MM |
| F | G | H | J | K |
| SCREW | WOOD DOWEL | WOOD DOWEL | BOLT DOWEL | CAM |



| |
|---|
|  |
| X4 |
| Ø15 X 9MM |
| L |
| CAM |

HARDWARE LIST



X4

M

**FLAT WASHER
1.5T X M7 X 18MM**



X4

N

**SPRING WASHER
M7**



X6

P

**ALUMINIUM U
SHAPE HANDLE**

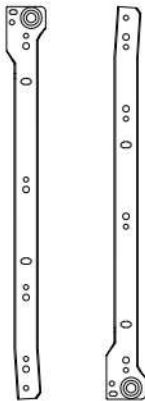

X2 SETS

Q1 & Q2

**DRAWER SLIDE
(350MM)**



X2 SETS

R1 & R2

**DRAWER SLIDE
(350MM)**

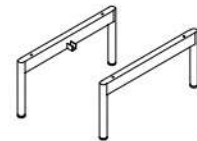

X2

S

**N SHP MTL LEG
(20X390X195XD22MM)**

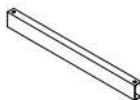

X1

T

**MTL SUP. BAR
20X40X398MM**

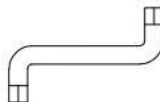

X1

U

ALLEN KEY M4

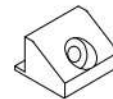

X4

V

**BACKPLY
STOPPER**

Top Tips before you start!

1. Please check that all parts are present before you start the assembly of your furniture, as once assembled, the furniture is exempt from our home approval policy.
2. For ease and speed of assembly, we recommend that before you commence each step of the assembly, that you identify all the parts required for the step.
3. For larger items, please ensure that you have sufficient space and people (as indicated on page 1) to assemble your product safely.
4. We recommend that, where possible, all items are assembled near to the area in which they will be placed in use, to avoid moving the product unnecessarily once assembled.
5. For the protection of your furniture, particularly items of high gloss finish, we recommend that the product is placed on a protected surface during assembly to prevent any damage.
6. During assembly please take care not to over-tighten any fittings, as this may damage the product.

Care and Maintenance of your Furniture

- Please periodically check all fittings and re-tighten as necessary.
- Please do not drag or pull your furniture.
- Wipe occasionally with a soft cloth slightly dampened with water. Then buff with a dry clean soft cloth.
- Never allow any kind of liquid to remain on your furniture. Absorption can cause wood to warp or finishes to de-laminate.
- Please do not sit or stand on this item.

Special Tips for Fitting Minifix Cam (Cam-Lock), and Minifix Bolt (Cam-Bolts)

CAM-BOLT

Tighten until shoulder is flush with panel. Do not overtighten or undertighten (see example below).

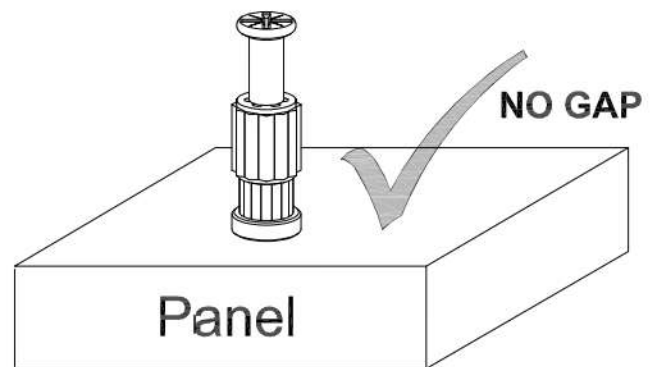
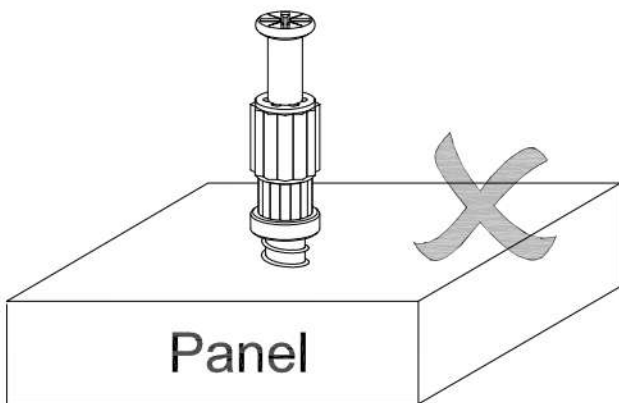
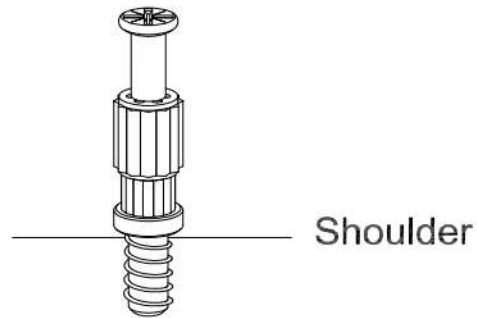

CAM-LOCK

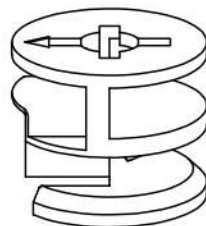

WHEN TIGHTENING CAM-LOCK
Turn The Cam-Lock Clockwise Until
The Arrow Points in The Position as Below !

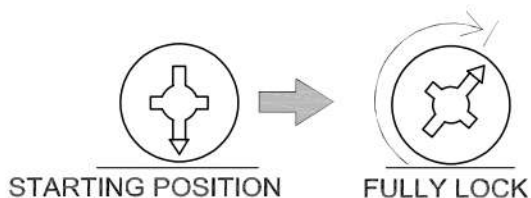

See this Arrow Points !

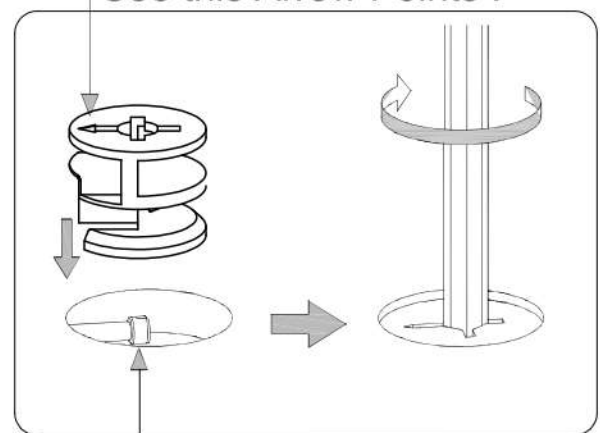

Bolt's head needs to be in centre !

ASSEMBLY INSTRUCTION

DESCRIPTION: 8323

STEP 1

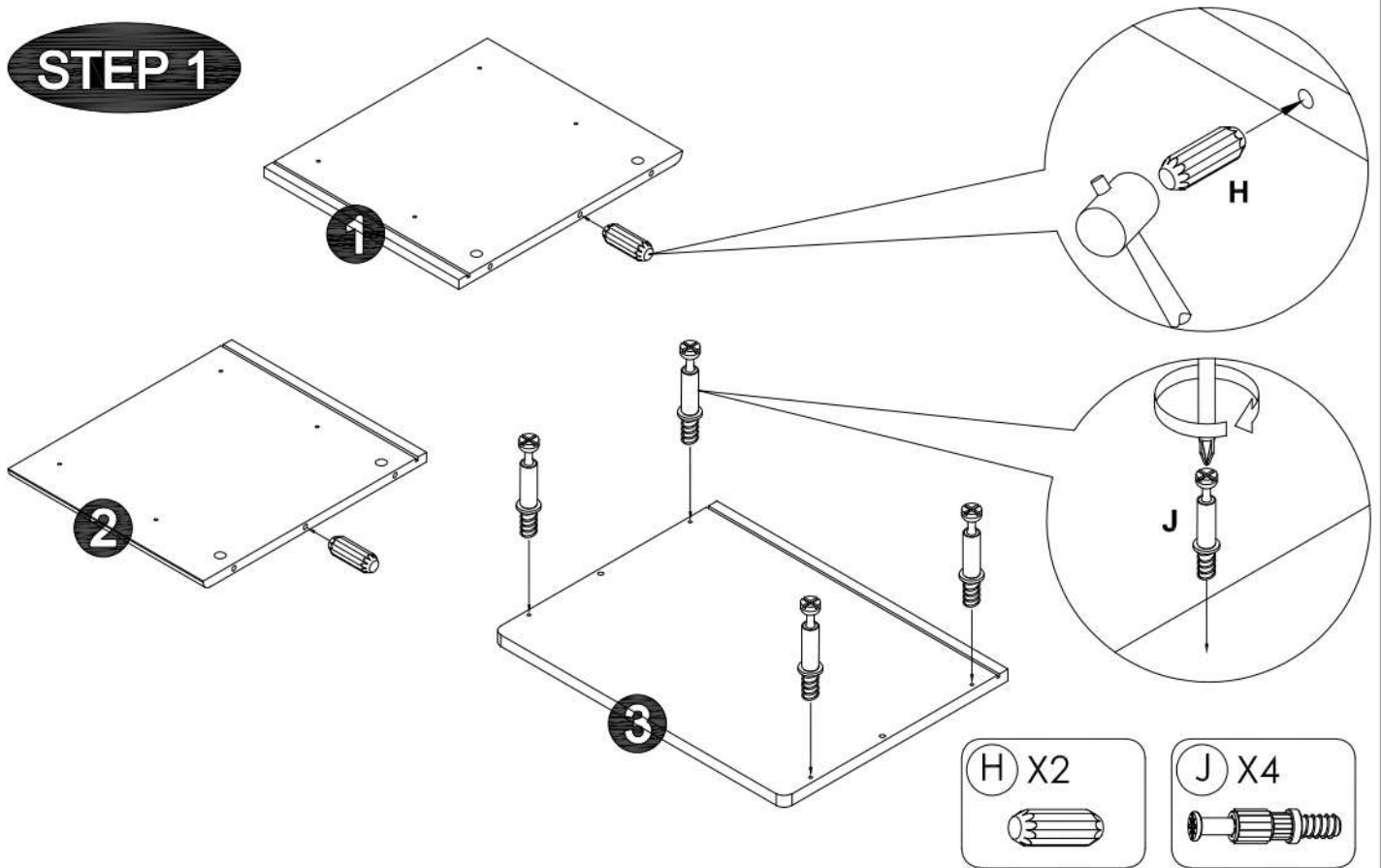

STEP 2

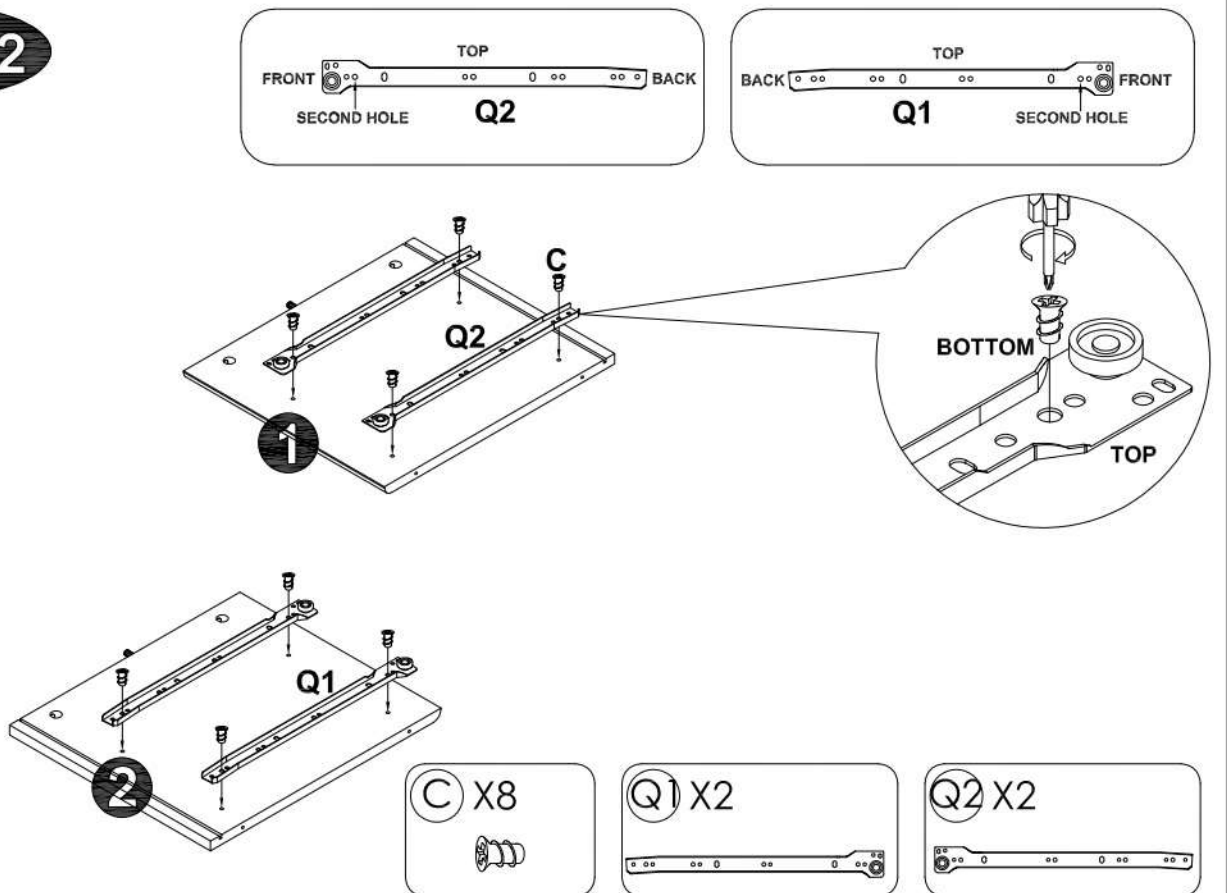

ASSEMBLY INSTRUCTION

DESCRIPTION: 8323

STEP 3

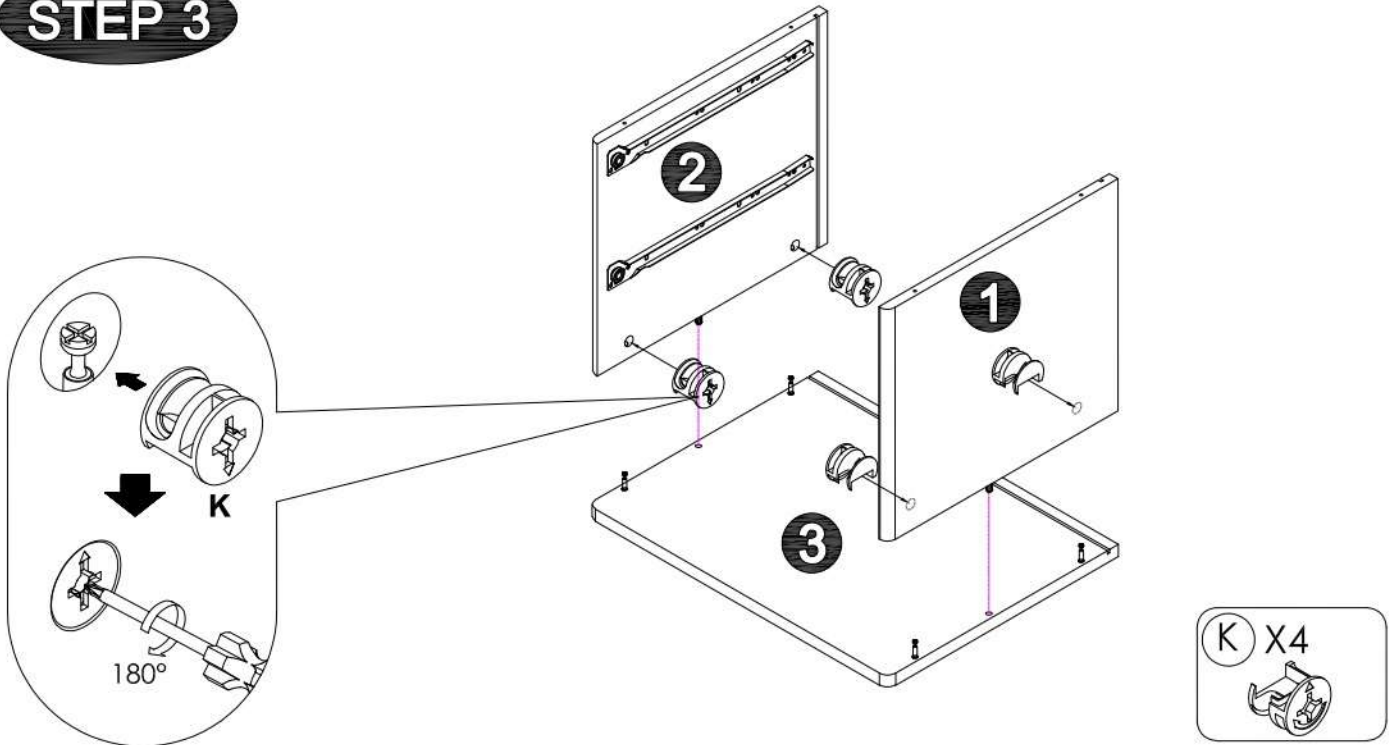

STEP 4

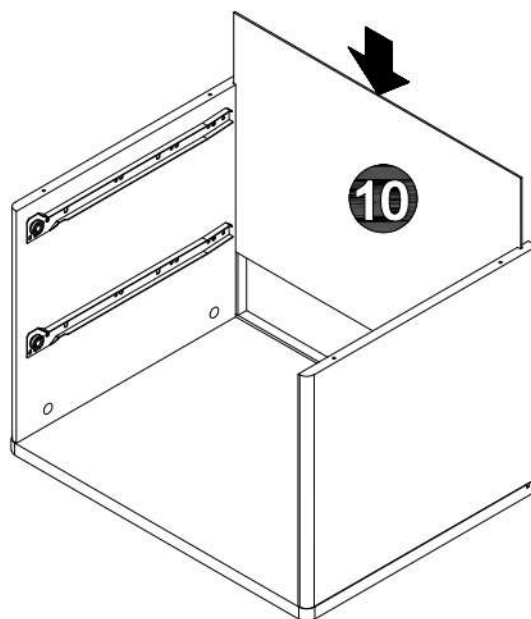

**ASSEMBLY
INSTRUCTION**

**DESCRIPTION:
8323**

STEP 5

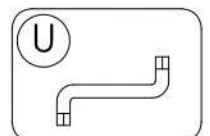
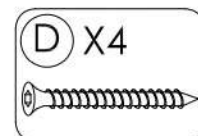
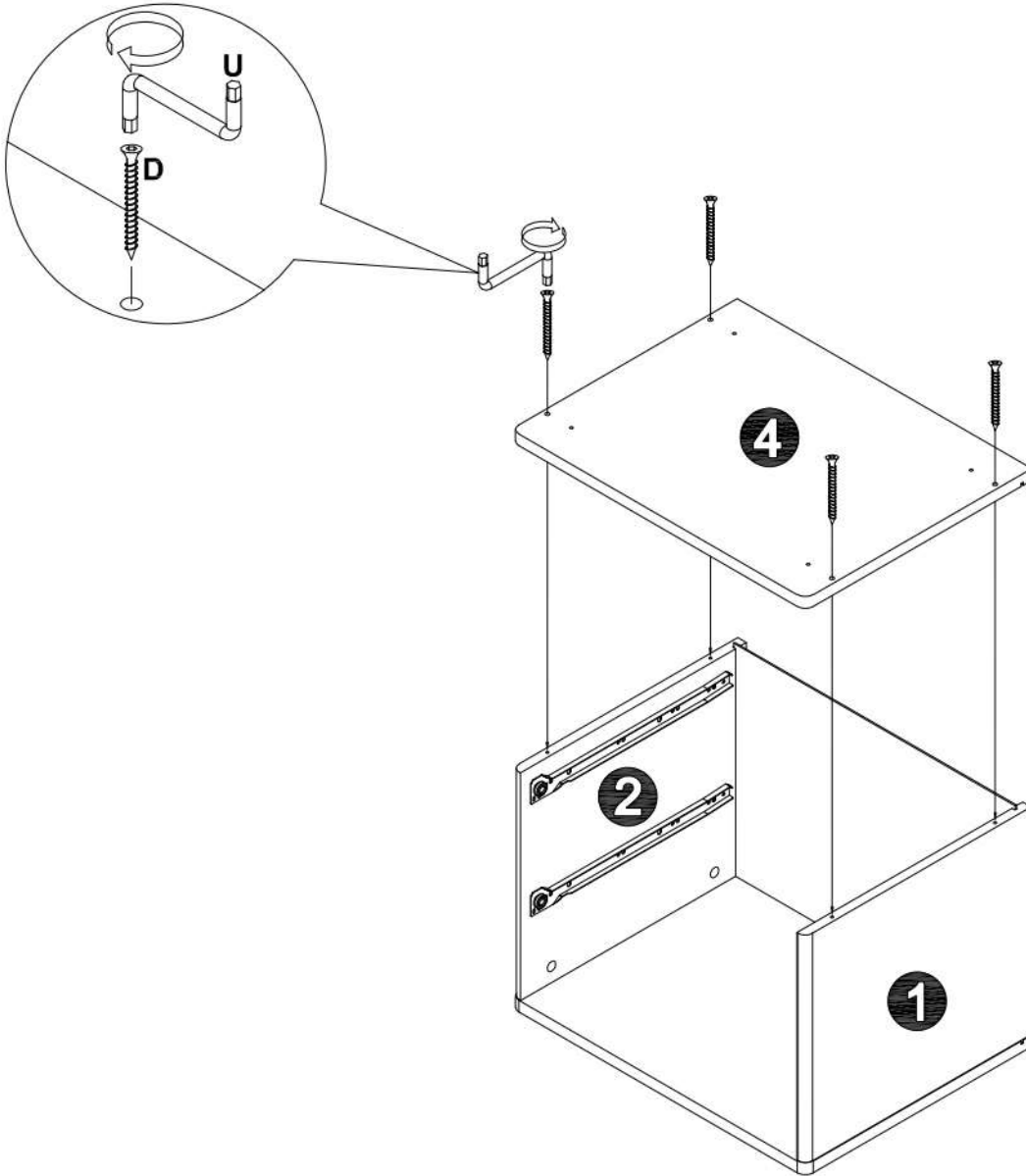

ASSEMBLY INSTRUCTION

DESCRIPTION: 8323

STEP 6

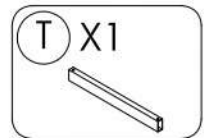
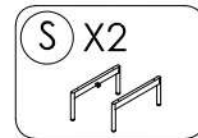
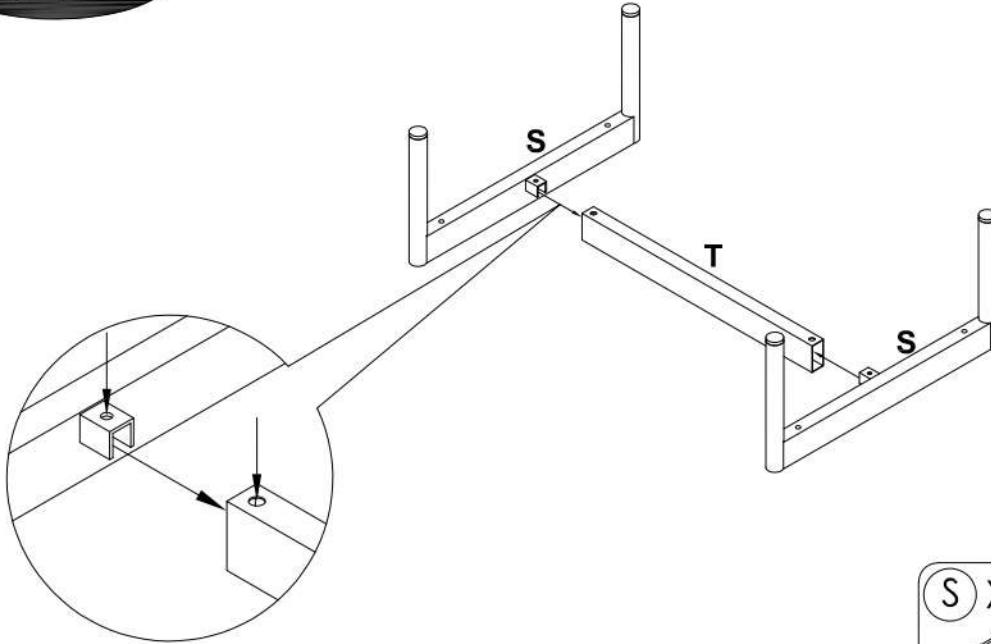

STEP 7

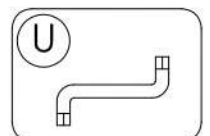
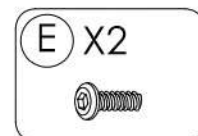
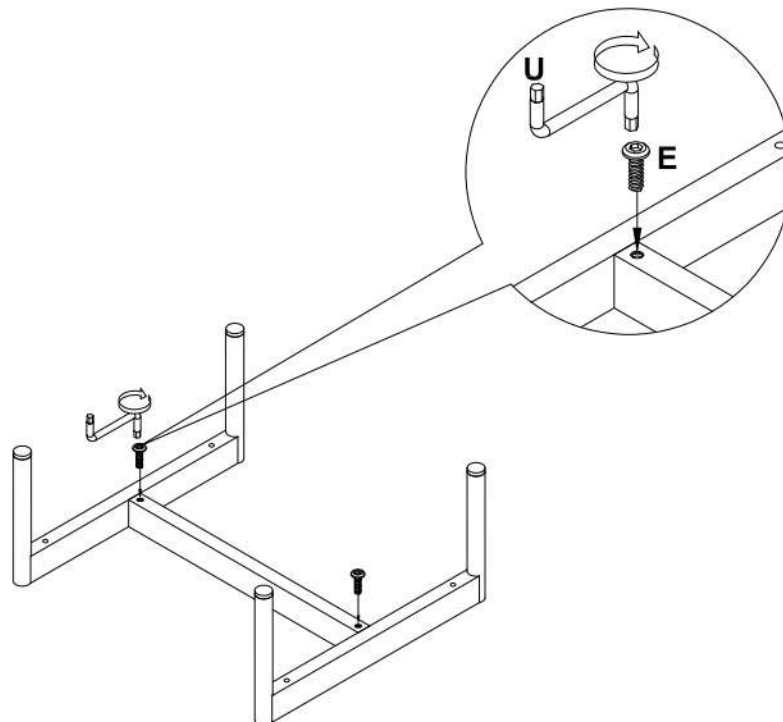

NOTE :
DO NOT FULLY TIGHTEN.

**ASSEMBLY
INSTRUCTION**

**DESCRIPTION:
8323**

STEP 8

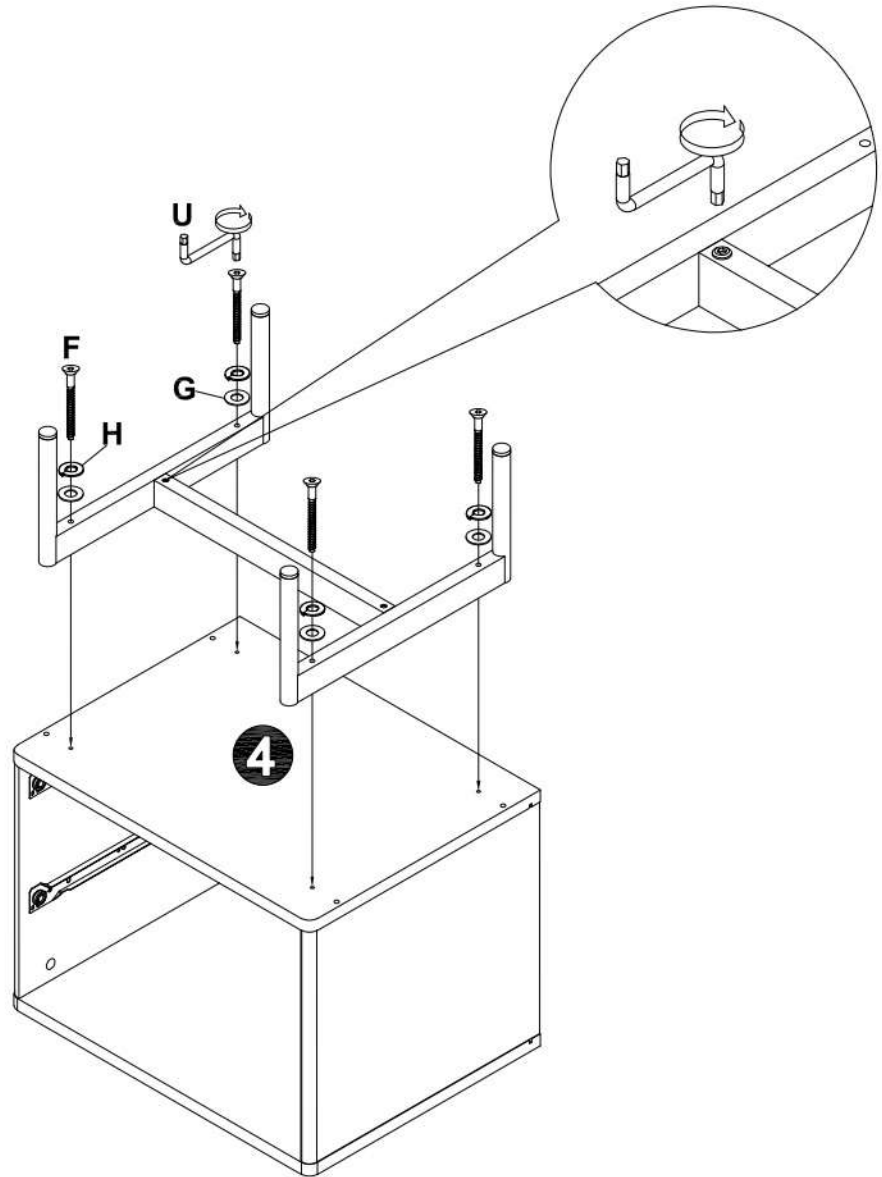

NOTE :
FULLY TIGHTEN ALL BEFORE
CONTINUE TO STEP 9.

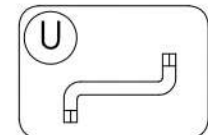
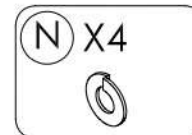
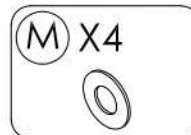
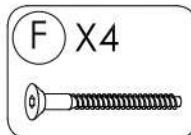

ASSEMBLY INSTRUCTION

DESCRIPTION: 8323

STEP 9

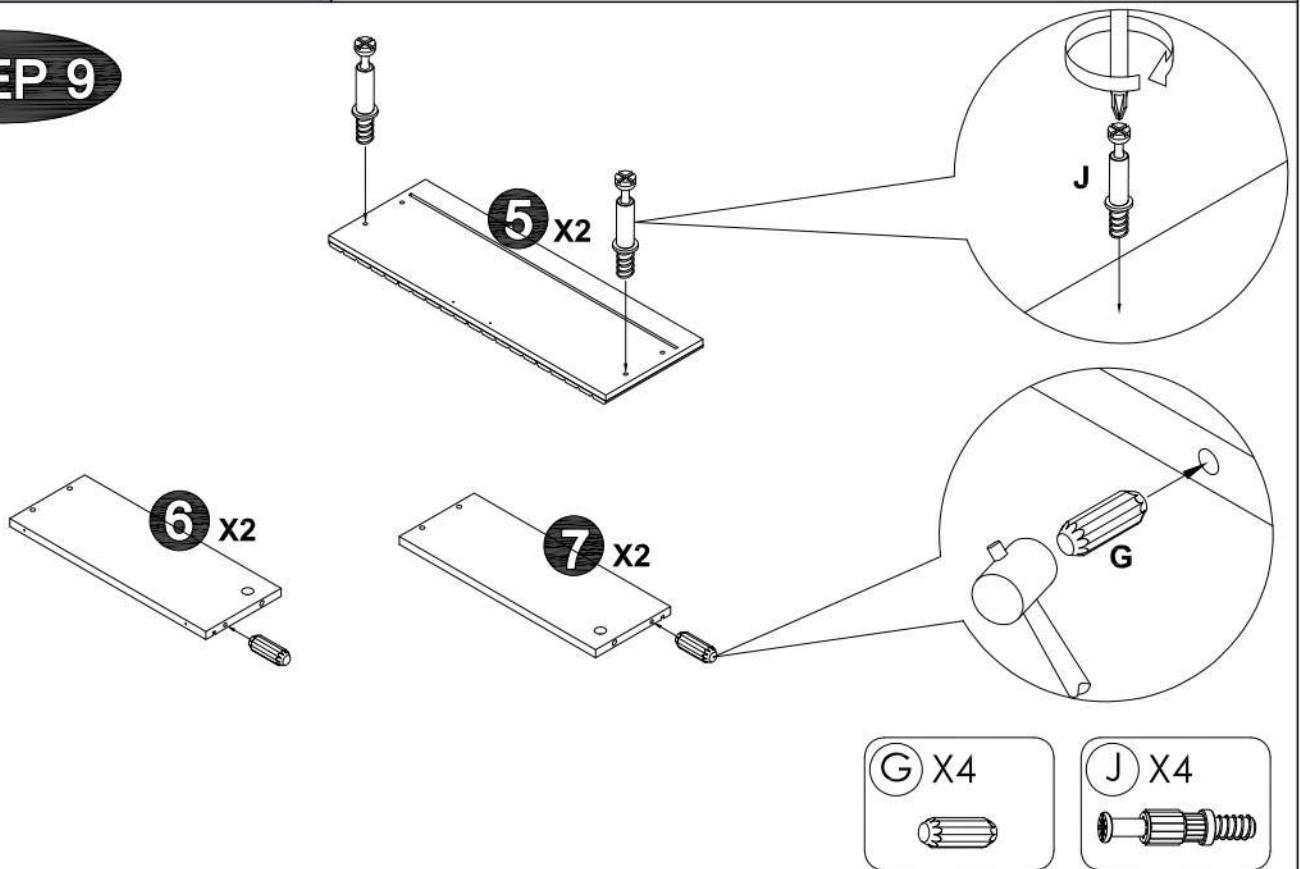

STEP 10

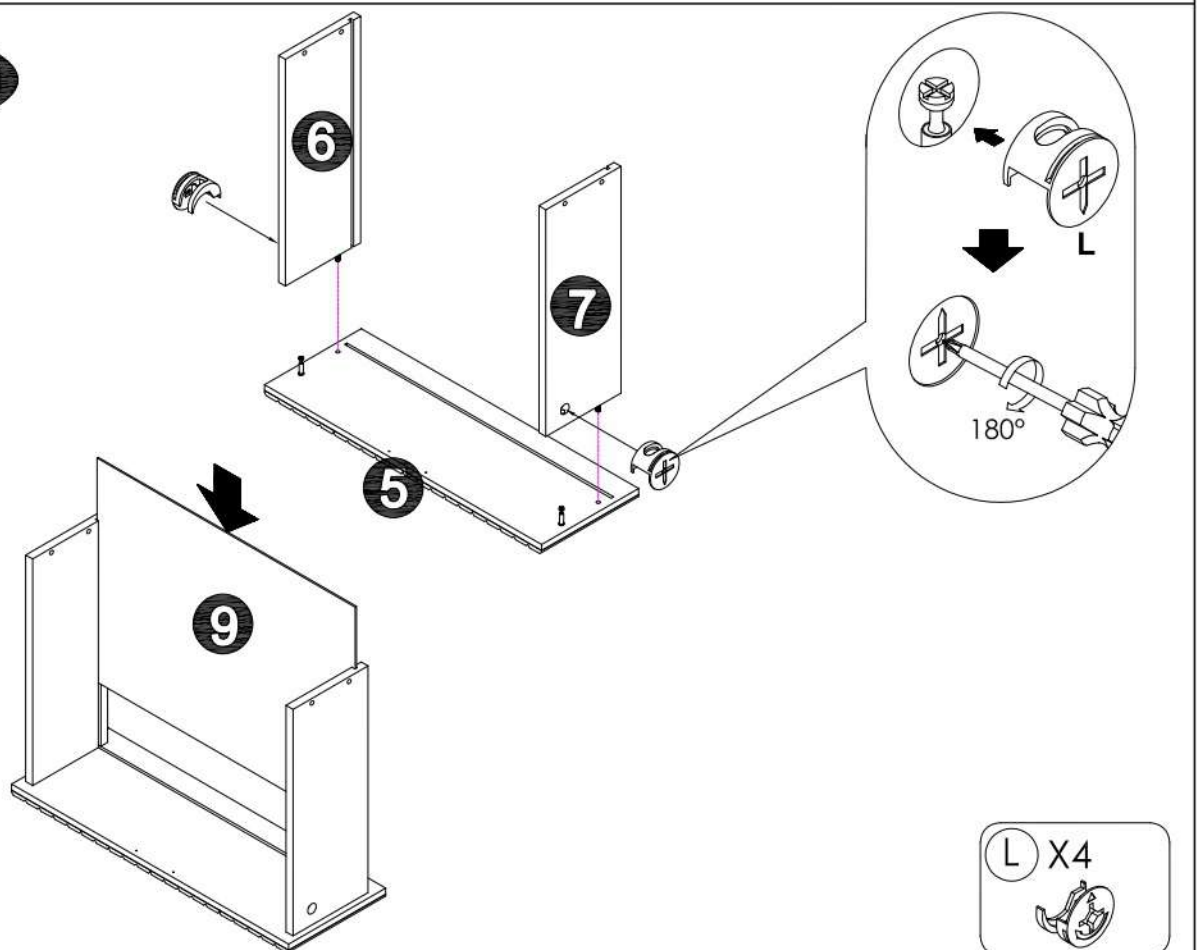

X2

ASSEMBLY INSTRUCTION

DESCRIPTION: 8323

STEP 11

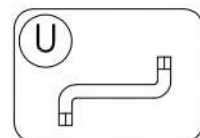
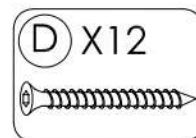
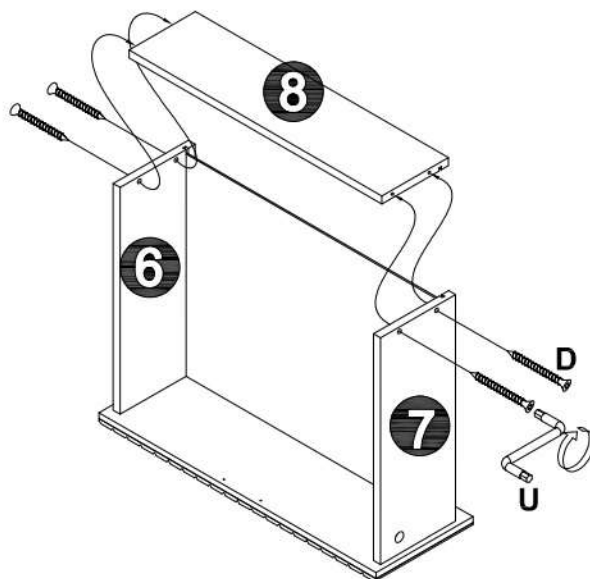

X2

STEP 12

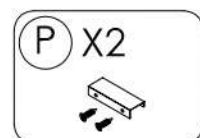
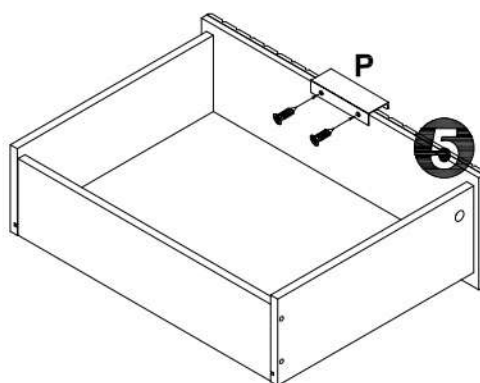

X2

**ASSEMBLY
INSTRUCTION**

**DESCRIPTION:
8323**

STEP 13

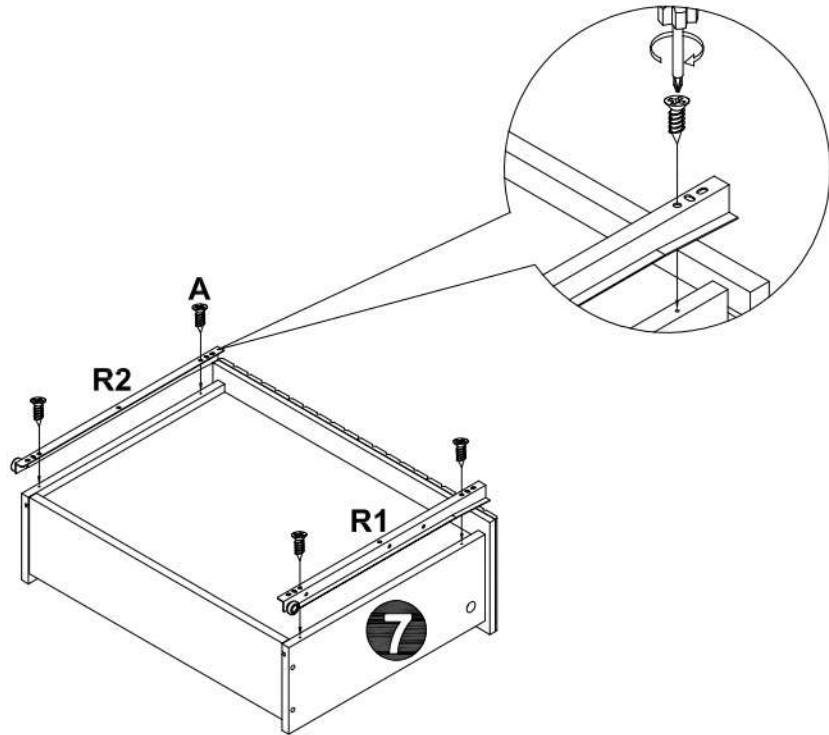

X2

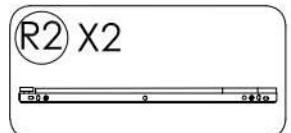
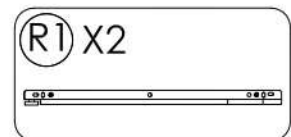
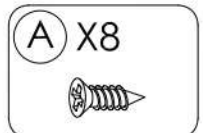
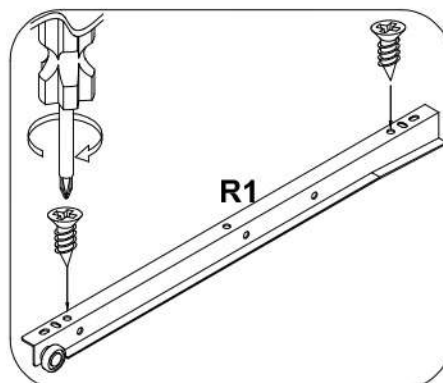
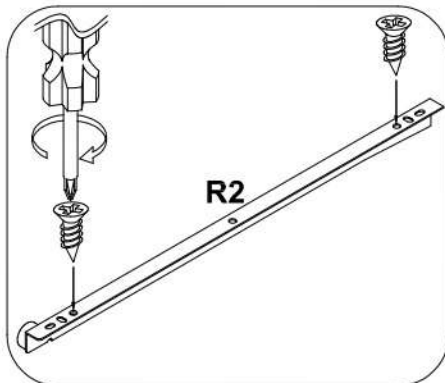

ASSEMBLY INSTRUCTION

DESCRIPTION: 8323

STEP 14

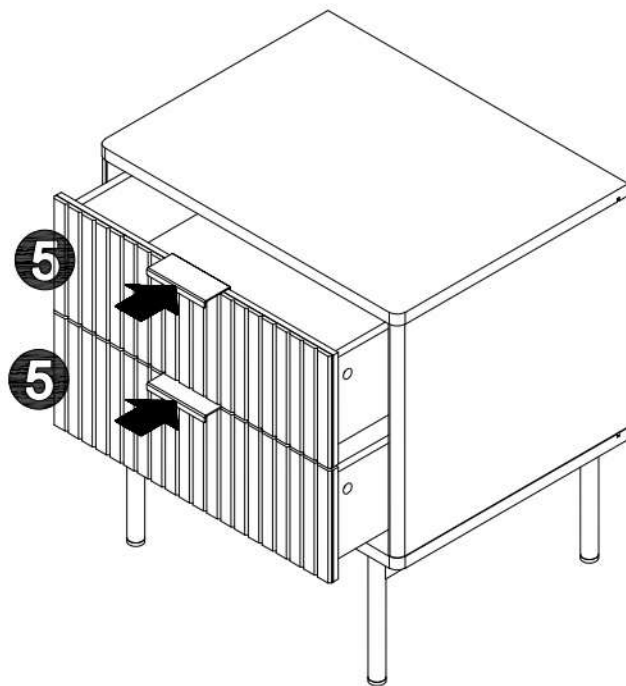

STEP 15

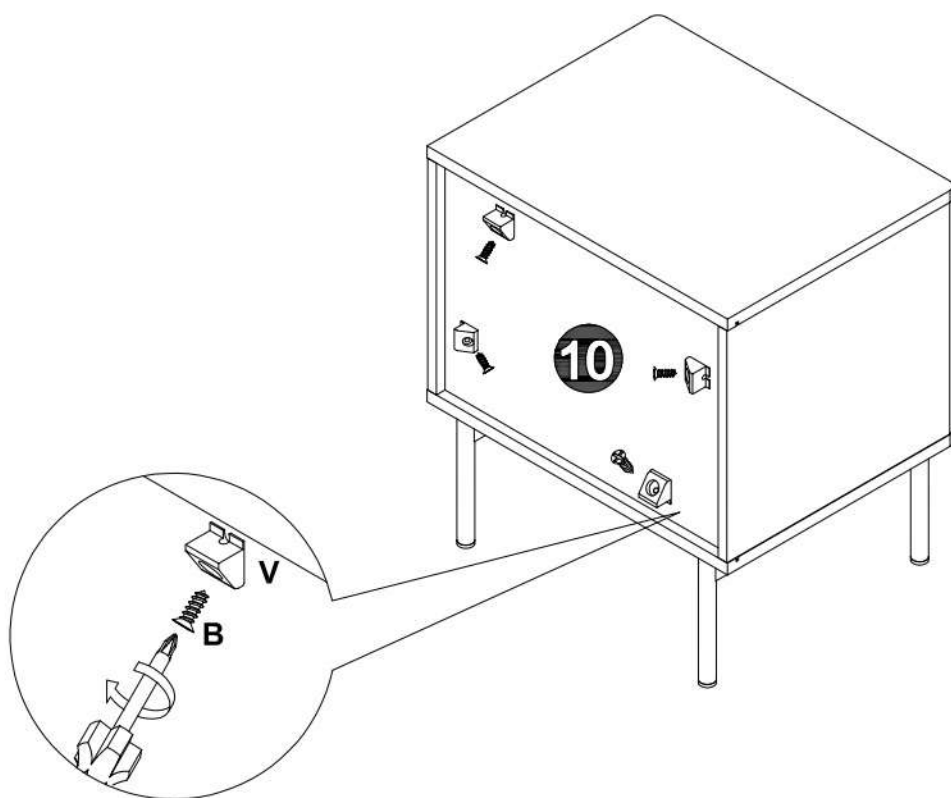

B X4



V X4



**ASSEMBLY
INSTRUCTION**

**DESCRIPTION:
8323**

STEP 16

WALL

