

# TEMPLE & WEBSTER

## ASSEMBLY INSTRUCTIONS



### STA2DMOK

*"Read these instructions and follow steps carefully to ensure you assemble the product correctly and avoid damages. Check that all parts and hardware have been provided before assembling the product. Place all contents on a clean, soft-flat surface to avoid scratching the product."*

**▲ CAUTION :**  
 Only tighten bolts to 80% at first. Once all parts have been assembled, fully tighten all hardware.  
 To prevent damage to threads, do not use a power tool and do not overtighten bolts.  
 Use two people to lift and turn the product when assembling.  
 Do not attempt with only one person and do not roll onto legs.  
 Keep all hardware and small parts away from children."



PART LIST		
ITEM	DESCRIPTION	QTY
A	Structure	1 PC
B	Legs part	3 PC

HARDWARE LIST		
ITEM	DESCRIPTION	QTY
1	JCB BOLT M6x60MM 	8 pcs
2	Washer 	6 pcs
3	Allen Key 4 mm 	1 PC
4		
5		
6		
7		
8		

STEP 1 :

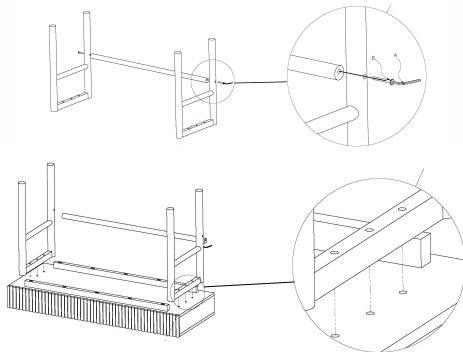

STEP 2 :

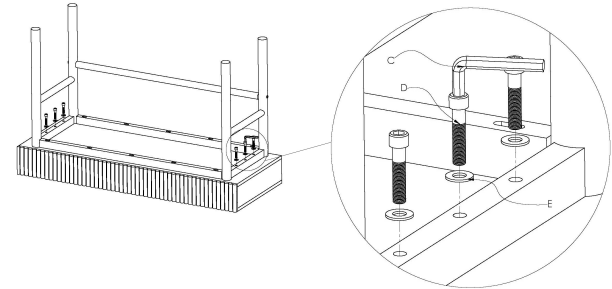

STEP 3 :

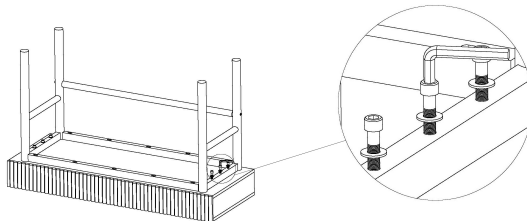

STEP 4 :

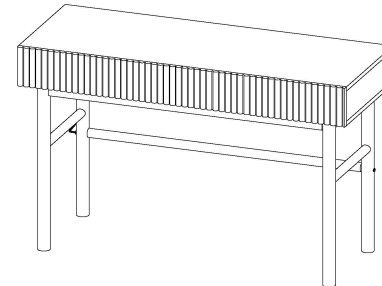

COMPLETED ASSEMBLY