

# TEMPLE & WEBSTER

## ASSEMBLY INSTRUCTIONS AACAOBBU/AACAOBGY

Read these instructions and follow steps carefully to ensure you assemble the product correctly and avoid damages. Check that all parts and hardware have been provided before assembling the product. Place all contents on a clean, soft-flat surface to avoid scratching the product



CAUTION:

Only tighten bolts to 80% at first. Once all parts have been assembled fully tighten all hardware

To prevent damage to threads, do not use a power tool and do not overtighten bolts.

Use two people to lift and turn the product when assembling.

Do not attempt with only one person and do not roll on to legs.

Keep all hardware and small parts away from children.



PART LIST		
ITEM	DESCRIPTION	QTY
A	HEADBOARD	1PC
B	SIDE RAIL	2PCS
C	FOOTBOARD	1PC
D	CENTRE RAIL	1PC
E	BED LEG	4PCS
F	SUPPORT LEGS	2PCS
G	SLATS	2PCS

HARDWARE LIST			
ITEM	DESCRIPTION		QTY
1	JCBC SCREW M8*30MM		16PCS
2	PAN HEAD WOOD SCREW M5*40MM		16PCS
3	JCBC SCREW M6*20MM		4PCS
4	BRACKET		4PCS
5	PAN HEAD WOOD SCREW M4*16MM		4PCS
6	PAN HEAD WOOD SCREW M4*30MM		20PCS
7	POTHOOK		2PCS
8	JCBC SCREW M6*15MM		2PCS
9	M5 ALLEN KEY (BALL SHAPE) LONG		1PC

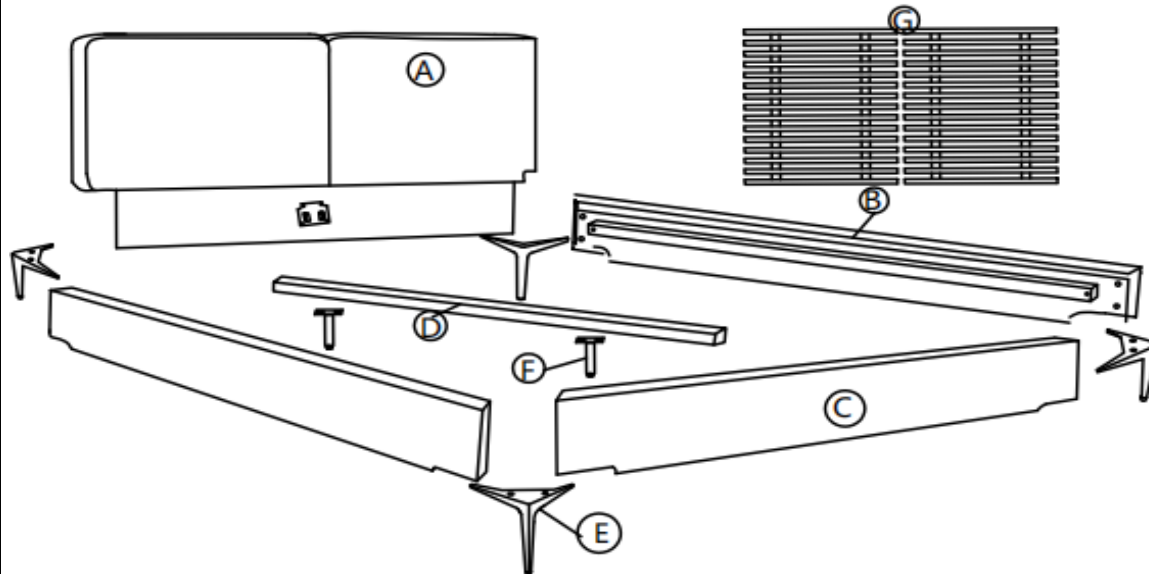

STEP 1:

①X8



⑨X1

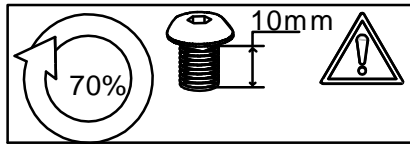
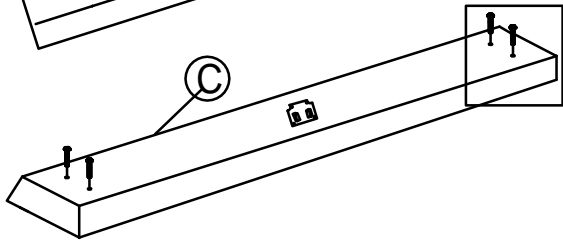
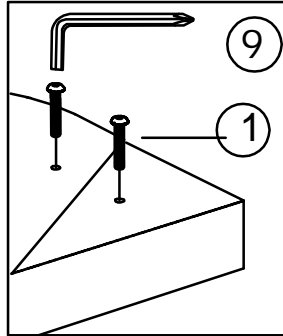
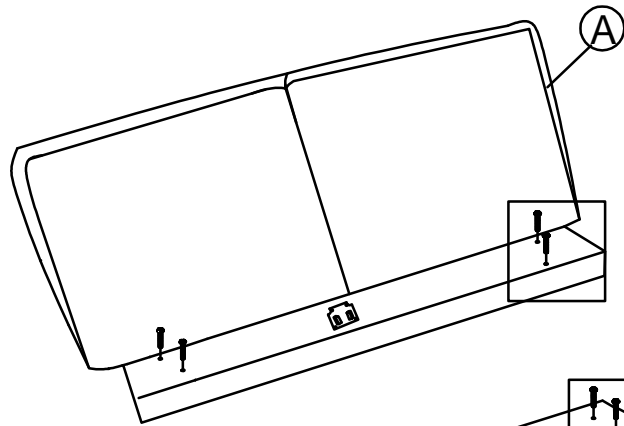

STEP 2:

①X8



④X4

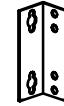

⑨X1

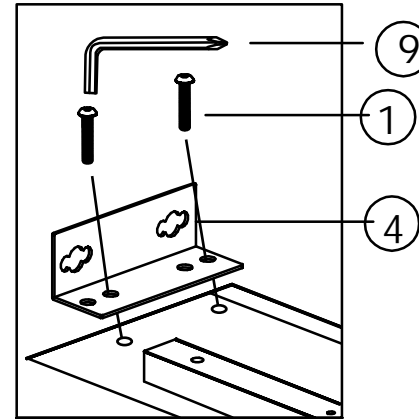
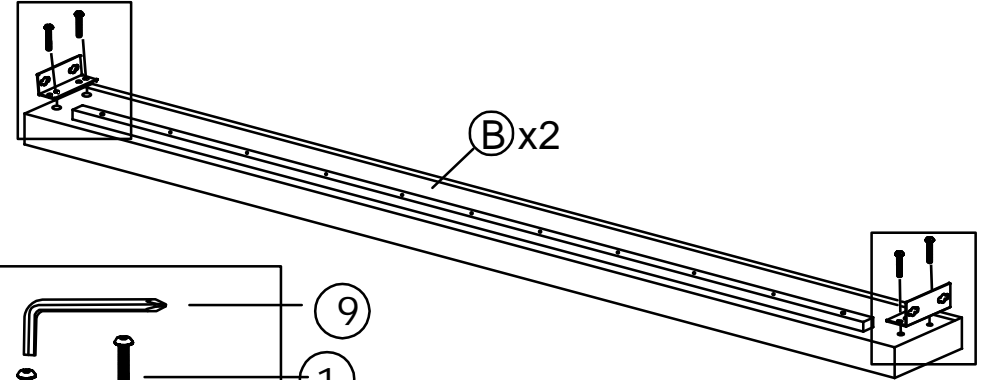
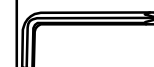

STEP 3:

⑨ X1

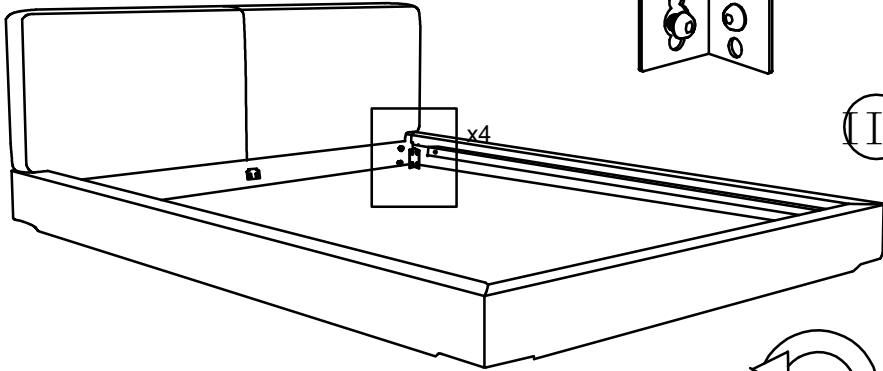

I

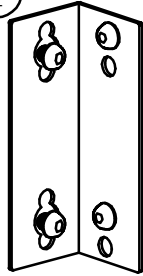

II

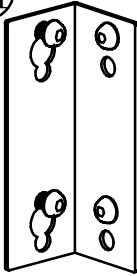

III

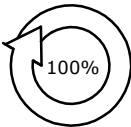
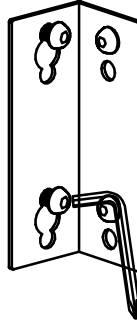

STEP 4:

② X12



⑨ X1

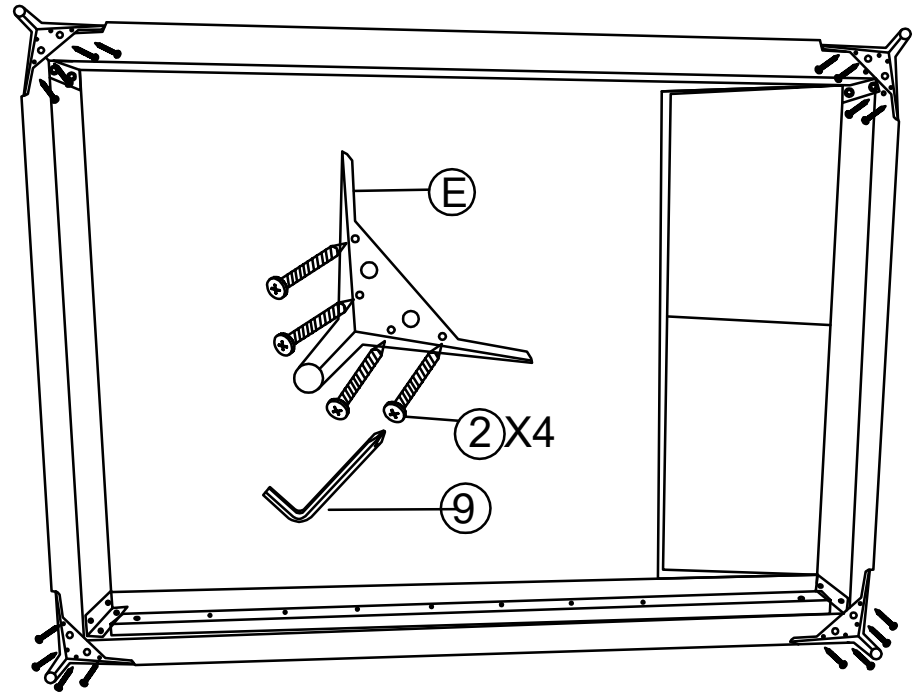

STEP 5:

③X4

⑤X4

⑦X 2

⑧X 2

⑨X1

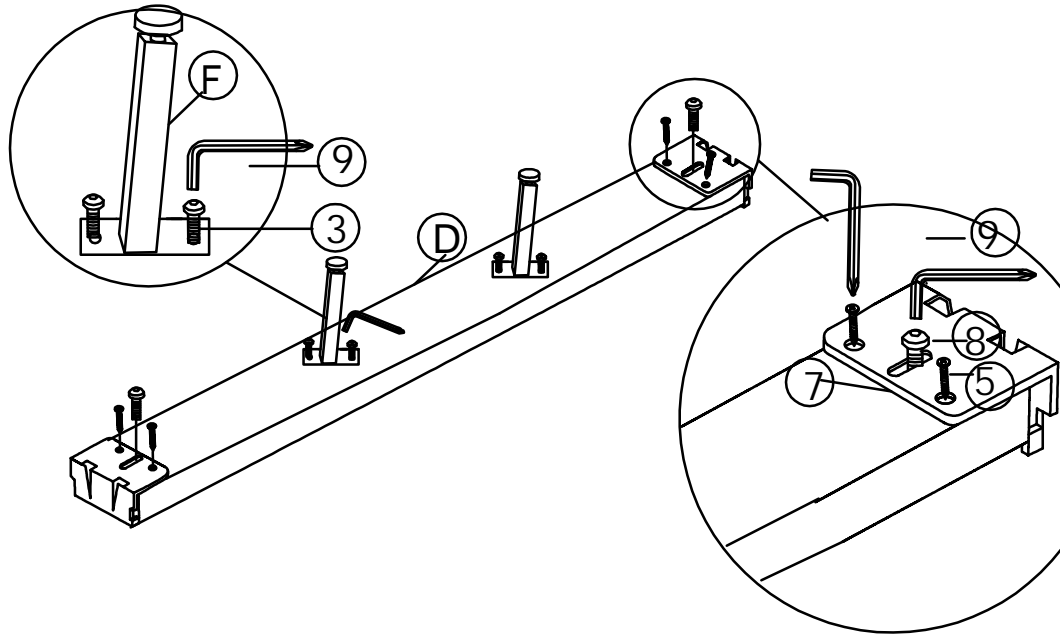

STEP 6:

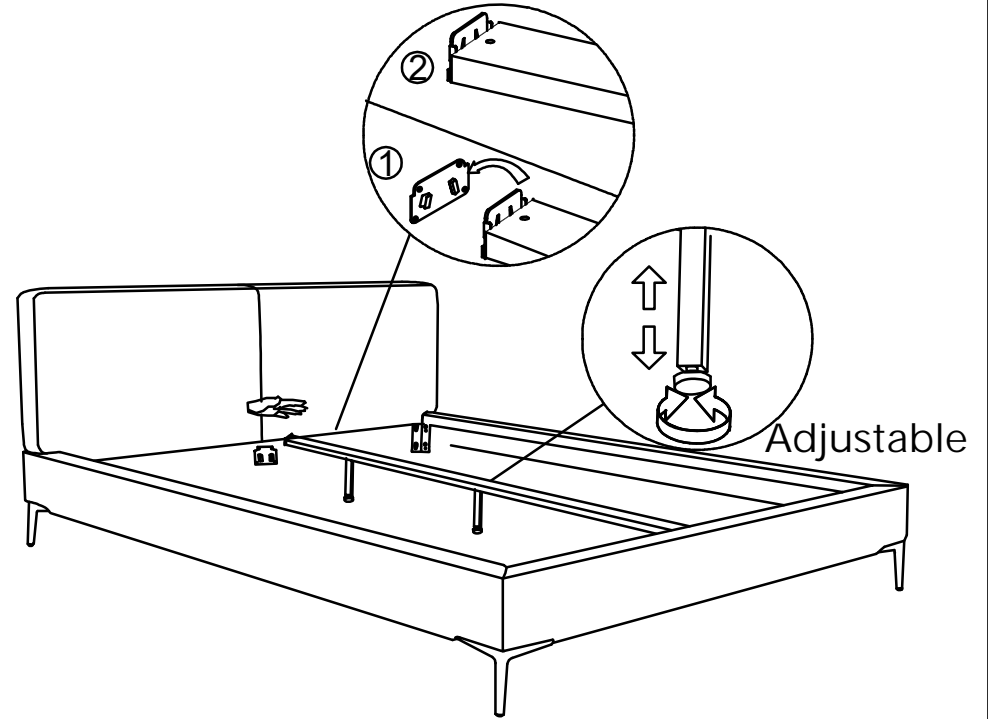

STEP 7

:

6X20

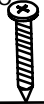

9X1

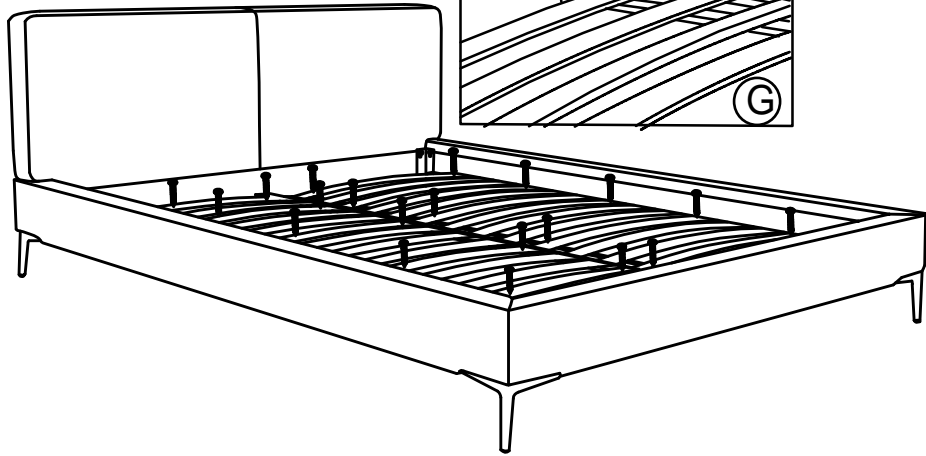
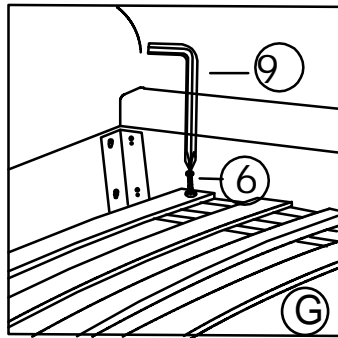

STEP 8:

