

Assembly Instructions

Suppliers are responsible for creating accurate and easy-to-follow assembly instructions where required. Assembly Instructions must adhere to QC requirements, and follow the Temple and Webster branding guidelines.

Critical Information

- Suppliers must use the attached template and guideline to create Assembly Instructions. Do not alter the template layout,
- Assembly Instructions must be printed on A4 paper, double-sided
- Font must be Montserrat. Fonts and assets are provided together with this guideline
- Step numbers must be clearly visible at the top left of every page
- Page numbers must be included on the right bottom of each page
- Each step must include images of hardware, parts and tools required for that step
- Maximum 2 steps per page
- Images must be large. Images should be zoomed in where required to show details
- Assembly Instructions must be packed inside product carton, as per T&W Packaging Guideline

For new products, assembly instructions must be sent by email to quality@templeandwebster.com.au for approval. No assembly instructions should be printed or packed without TPW approval.

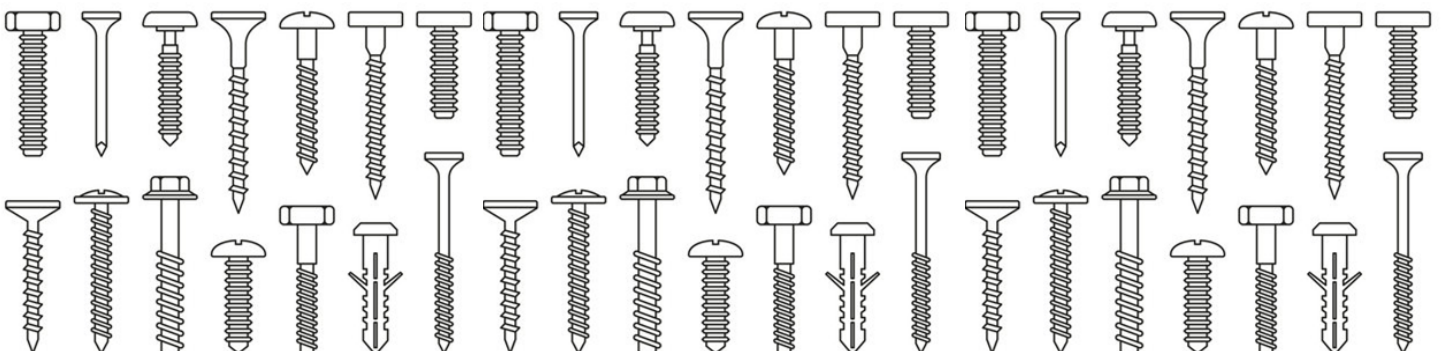

**TEMPLE &
WEBSTER**

**ASSEMBLY
INSTRUCTIONS**

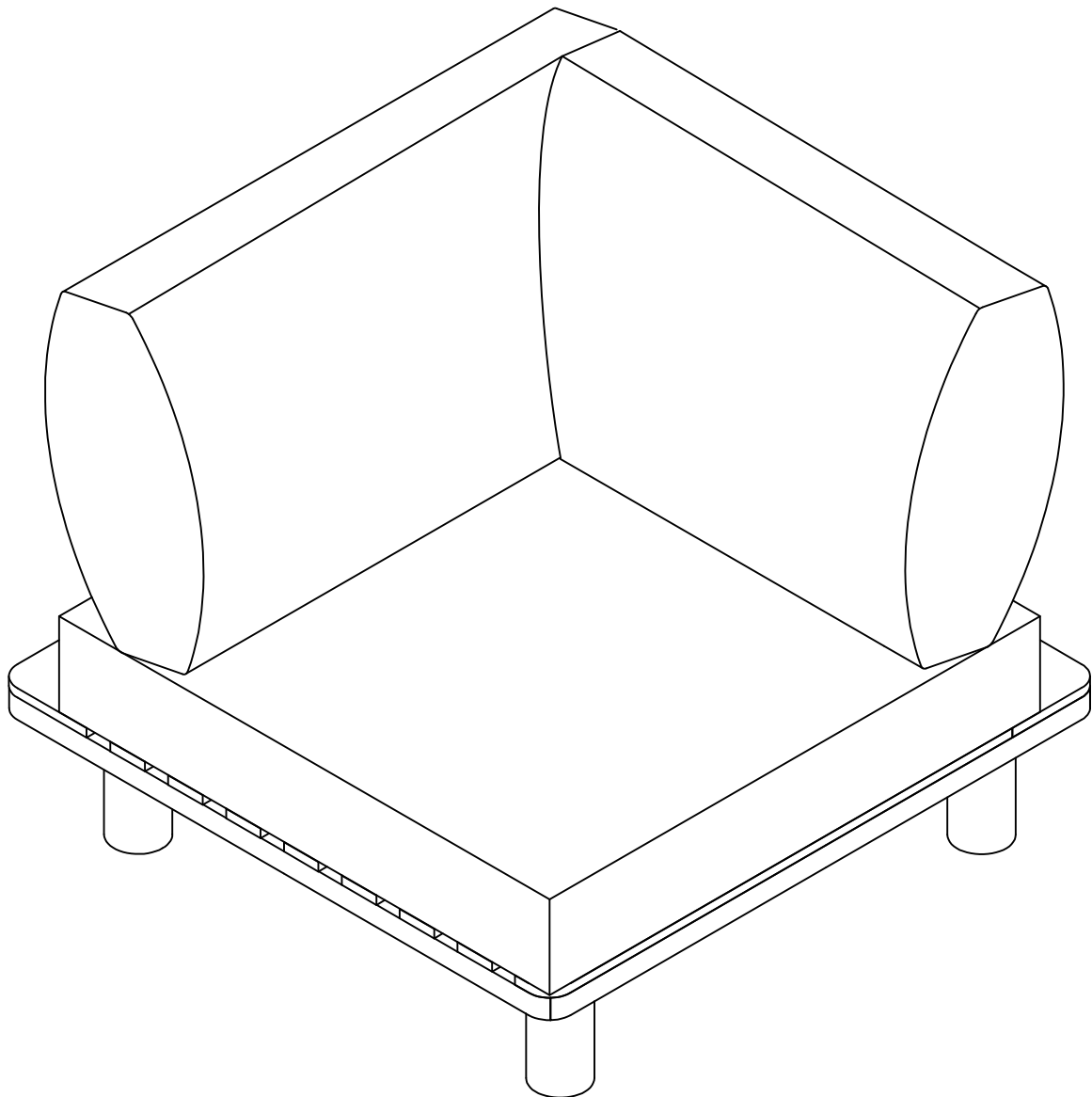

**CLIFTON OUTDOOR MODULAR
SOFA SET, CORNER CHAIR**

Read first, enjoy forever

Assembly tips

- Assemble your product on a level surface and lay something soft underneath to protect potential floor damage.
- Don't over tighten screws. During assembly we recommend tightening to approximately 70% tightness. Only tighten hardware 100% when fully assembled.
- Keep children away from assembly area as bags and small parts can pose a choking hazard.
- Make sure you have enough space to layout parts before starting. We recommend assembling your item in its final location.
- Do not stand on or put weight on the parts as it may warp or damage product.
- We do not recommend the use of drills or power tools (unless specified) as it may damage the product or hardware. Use hand held screwdrivers only.
- It is best that two people assemble the product as some products may be too heavy for one person. Check this booklet for guidance.

Safety, care and maintenance

- To reduce the risk of injury, always secure storage furniture to walls and/or floors by using tip-over restraints.
- Never let children climb or hang on drawers, doors or shelves.
- To protect your product and your home, we recommend using coasters, placemats, rugs and other protective items.
- Screws may loosen over time. We recommend setting a reminder to tighten up every six months.
- Remove any liquid spills immediately using a clean cloth with mild detergent. Do not use bleach or abrasive cleaners. Always test any cleaning agent in an inconspicuous spot first to know if it is suitable.

Recycling

We hope that you love your product forever, but we know situations change. In the event that you wish to dispose of your product please consider some creative ways to give it a new home:

- If it's still in great shape, sell it on your favourite online marketplace!
- Give it a second life by affording it a fresh coat of paint.
- If you must dispose of it, why not donate it to your local charity or shelter for someone else to enjoy.

Please dispose of this product and packaging responsibly and recycle where possible. Scan the QR code to read more about Temple and Webster's commitment to a more sustainable future.



**TEMPLE &
WEBSTER**

Damaged or missing parts? Or just need help?
Contact us on service@templeandwebster.com.au





Parts list

ASSEMBLY INSTRUCTIONS CLIFTON OUTDOOR MODULAR SOFA SET, CORNER CHAIR SBCMSS

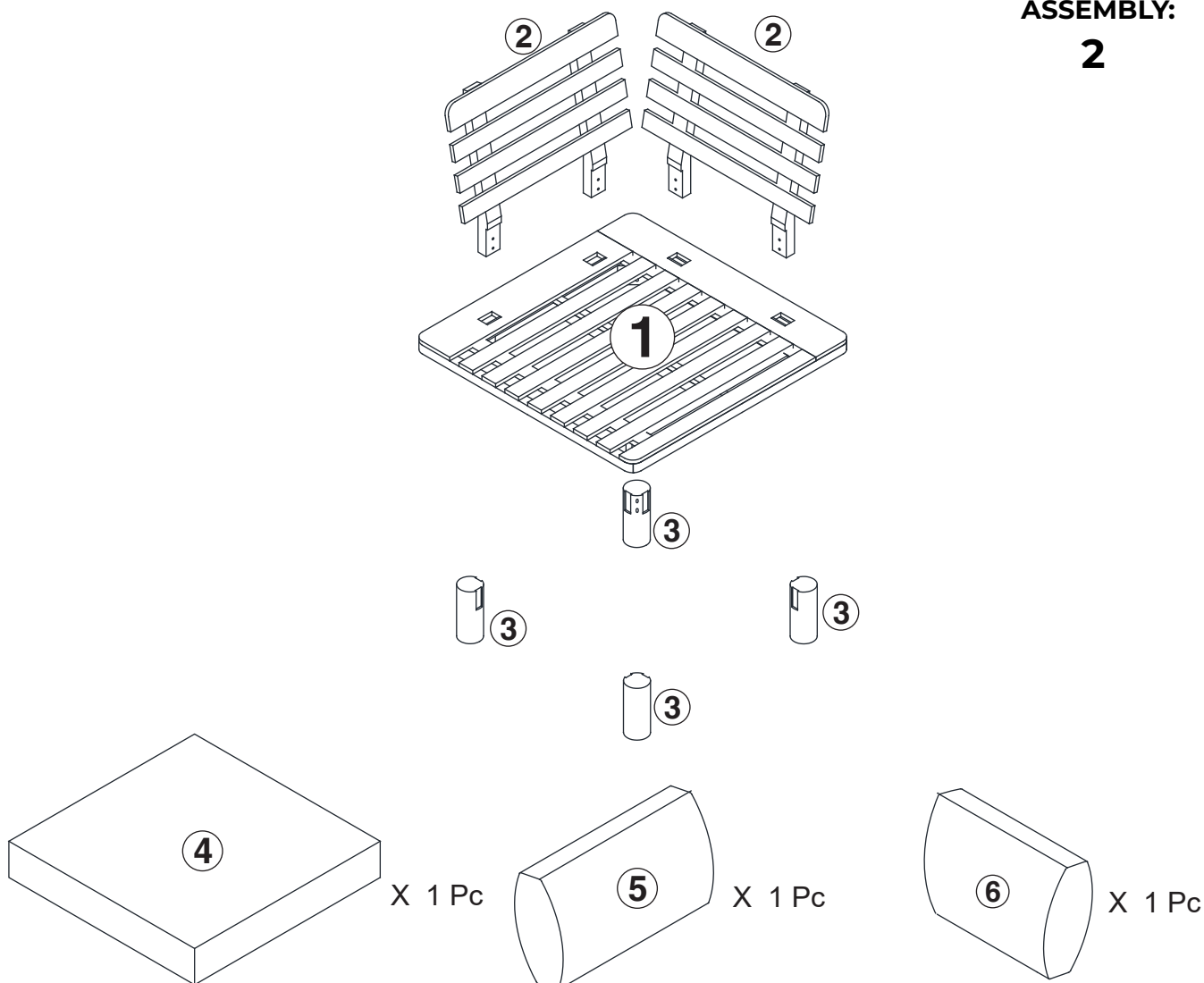
NUMBER OF PEOPLE REQUIRED FOR
ASSEMBLY:

2

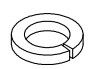

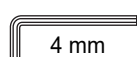
<p>A</p>  <p>M8 x 70 mm 8 Pcs</p>	<p>B</p>  <p>Ø8.5/20 x 2 mm 8 Pcs</p>	<p>C</p>  <p>Ø8.5/13x 2 mm 8 Pcs</p>
<p>D</p>  <p>M6 x 50mm 8 Pcs</p>	<p>E</p>  <p>4 mm 1 Pcs</p>	





**TEMPLE &
WEBSTER**

Damaged or missing parts? Or just need help?
Contact us on service@templeandwebster.com.au

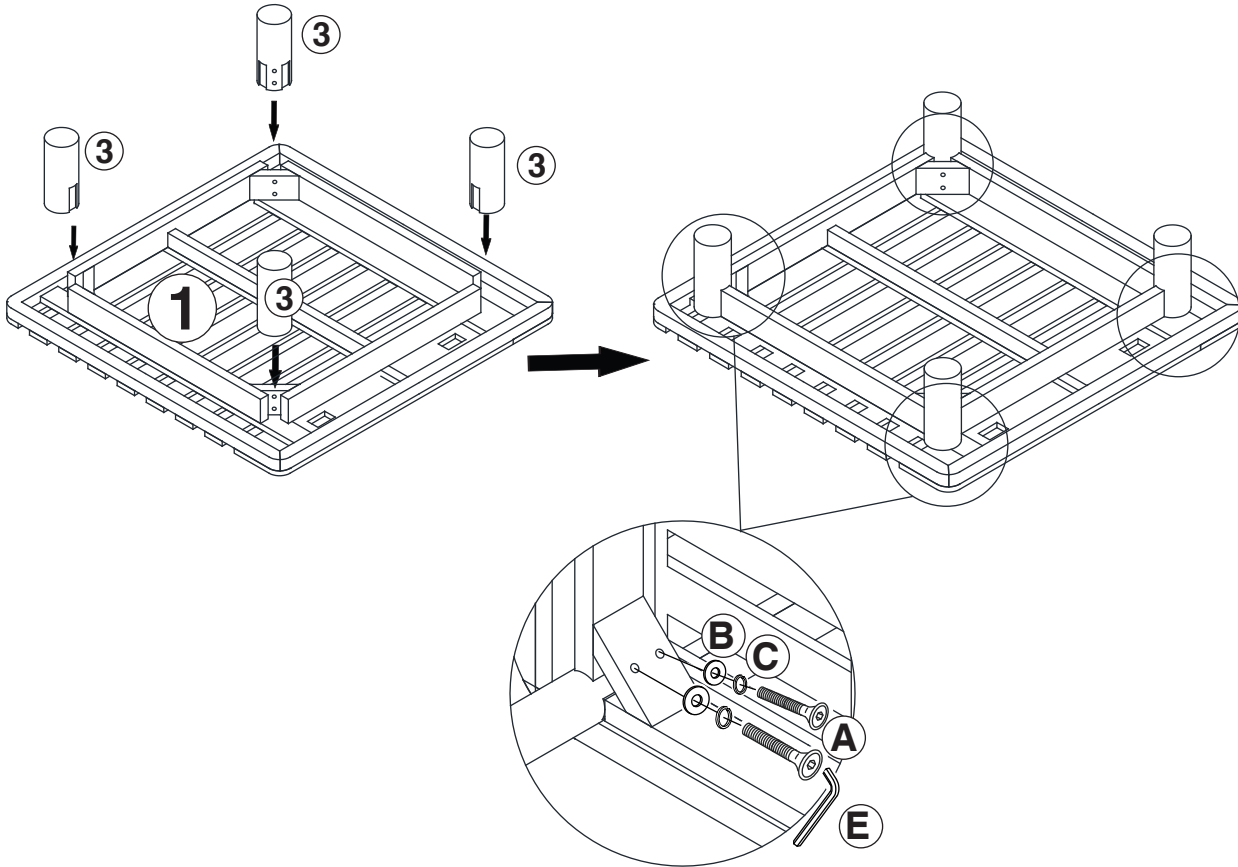
1.

Attach 4 x Legs (3) to Seat Panel (1) with 8x Bolt (A) With Washer (B),(C).





You will need :	
	M8 x 70 mm 8 Bolt
	Ø8.5/20 x 2 mm 8 Washer
	Ø8.5/13x 2 mm 8 Small washer
	4 mm 1 Allenkey

2.

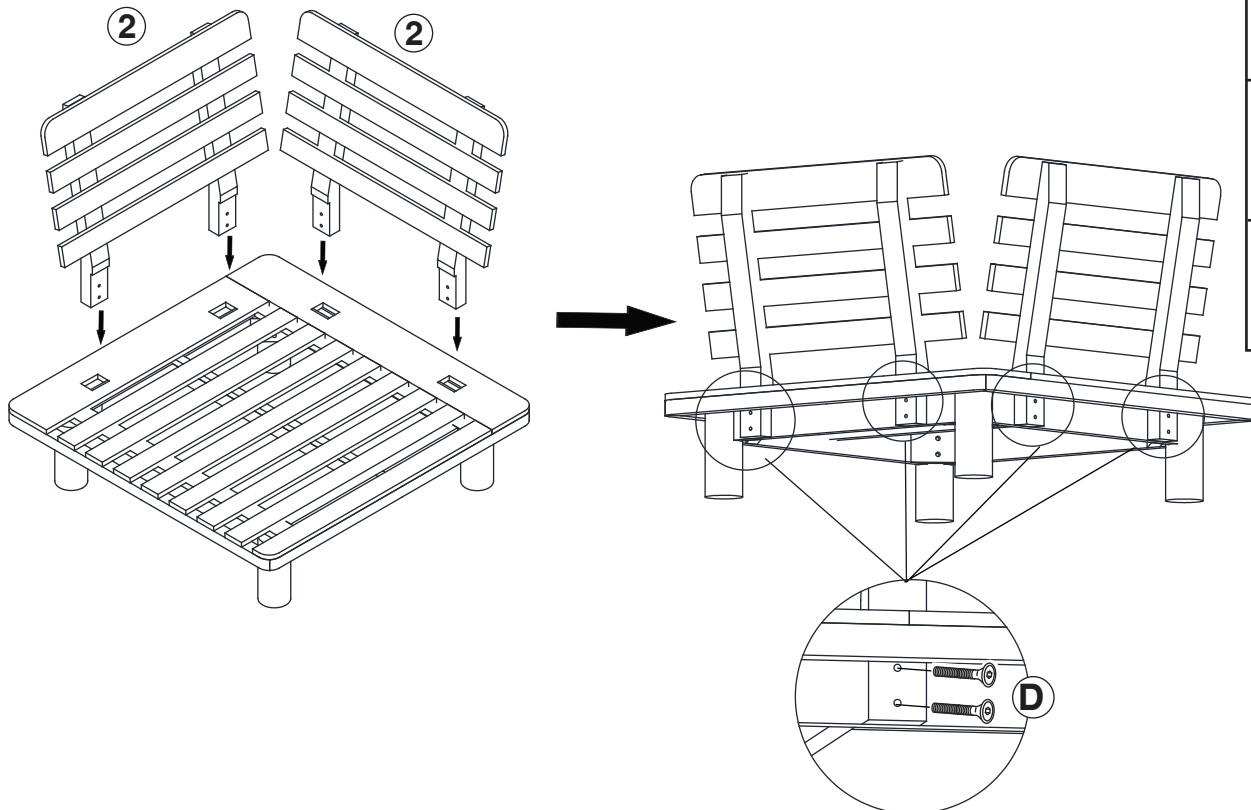
Attach 2x Backrest panel (2) to Seat Panel (1) with 8x Bolt (D).



You will need :	
	M6 x 50 mm 8 Bolt
	4 mm 1 Allen key

3. Attach 1x Seat Cushion **(4)** to Seat Panel .
Attach 1x Big Back Cushion **(5)** And 1x Small Back Cushion **(6)** to backrest Panel **(2)** .

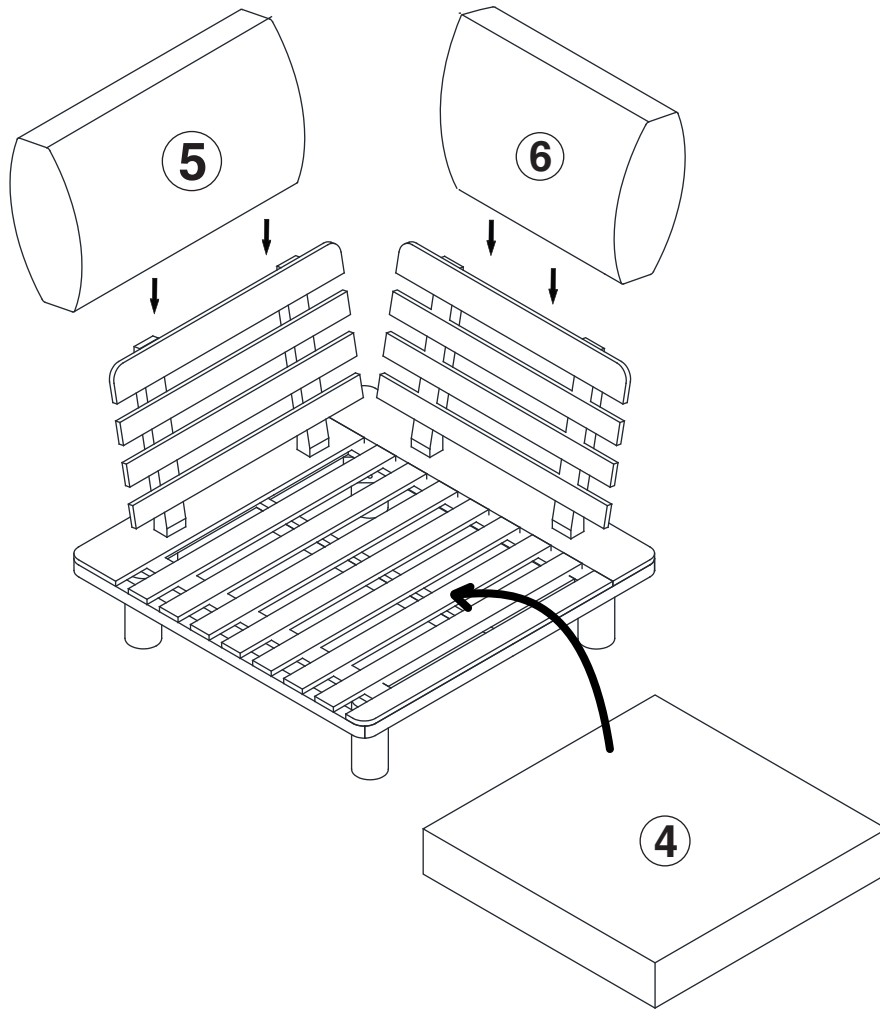

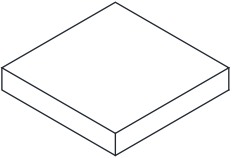
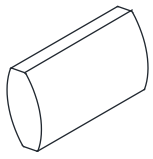
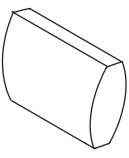
- You will need :**
-  1 seat cushion
 -  1 Big back cushion
 -  1 Small back cushion

4. Attach 2x Velcro of Seat Cushion **(4)** to Backrest Panel .

