

Read these instructions and follow steps carefully to ensure you assemble the product correctly and avoid damages. Check that all parts and hardware have been provided before assembling the products. Place all contents on a clean, soft-flat surface to avoid scratching the product.

CAUTION:

Only tighten bolts to 80% at first. Once all parts have been assembled, fully tighten all hardware.

To prevent damage to threads, do not use a power tool and do not over tighten bolts.

Use two people to lift and turn the product when assembling.

Do not attempt with only one person and do not roll onto legs.

Keep all hardware and small parts away from children.







Box of 1: Headboard(A), Footboard(B), Plastic caps(C&D), Plywood slats(E), Support legs(H), U-bracket(K), Hardware.

Box of 2: Siderail(F), Middle rail(G), Cross bar(I), Middle cross bar(J).

Please confirm you have all the parts listed before commencing assembly.



PART LIST		
ITEM	DESCRIPTION	QTY
A	HEADBOARD	1
B	FOOTBOARD	1
C	PLASTIC CAPS	12
D	PLASTIC CAPS	24
E	PLYWOOD SLATS	24
F	SIDERAIL	2
G	MIDDLE RAIL	1
H	SUPPORT LEGS	3
I	CROSS BAR	2
J	MIDDLE CROSS BAR	1
K	U-BRACKET	2

HARDWARE LIST		
ITEM	DESCRIPTION	QTY
1	SCREW M6x20mm 	12
2	SCREW M6x40mm 	9
3	HEX NUTS M6 	12
4	FLAT WASHER 	31
5	SCREW M6x55mm 	6
6	SPANNER 	1
7	ALLEN KEY 	1

STEP 1

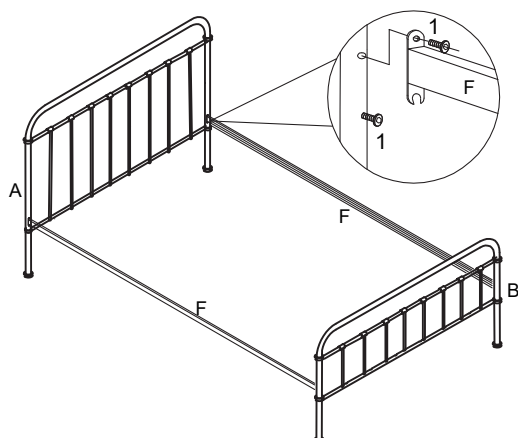

STEP 2

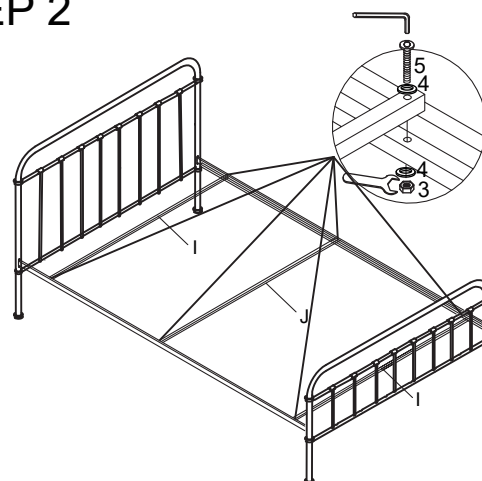

STEP 3

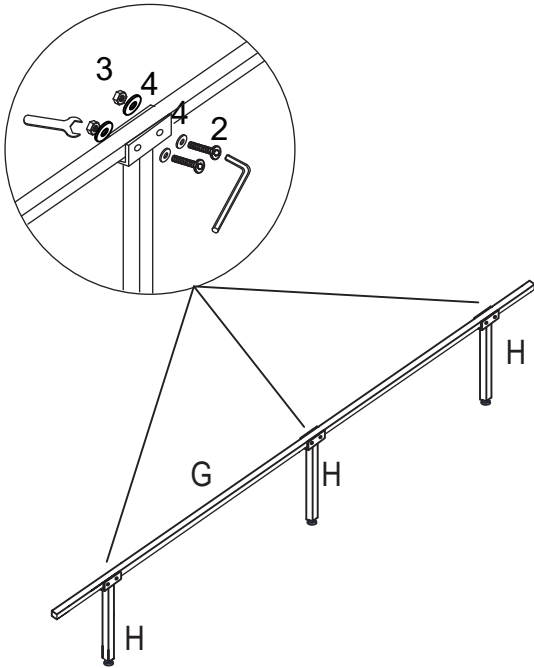

STEP 4

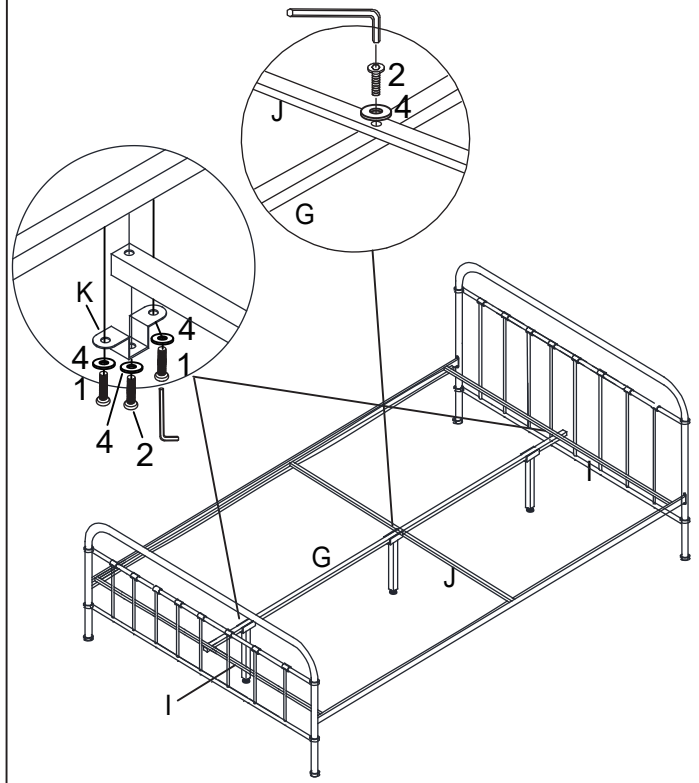

STEP 5

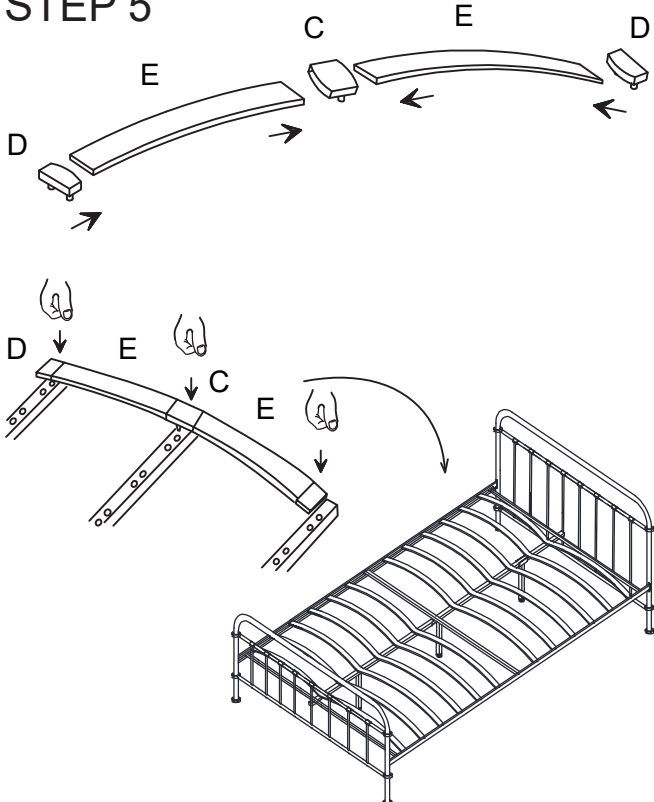

Note: Press side first then the middle

STEP 6

The feet should be adjusted up (i.e. off the ground) before moving the bed to prevent damaging the centre rail and support legs.

