

ASSEMBLY INSTRUCTIONS GLBELSBS

Read these instructions and follow steps carefully to ensure you assemble the product correctly and avoid damages. Check that all parts and hardware have been provided before assembling the product. Place all contents on a clean, soft-flat surface to avoid scratching the product.

⚠ CAUTION:

Only tighten bolts to 80% at first. Once all parts have been assembled, fully tighten all hardware.





To prevent damage to threads, do not use a power tool and do not overtighten bolts.

Use two people to lift and turn the product when assembling.

Do not attempt with only one person and do not roll onto legs.

Keep all hardware and small parts away from children.

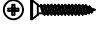
PART LIST		
ITEM	DESCRIPTION	QTY
A	SIDE LID	1PC
B	TOP LID	1PC
C	BACK LID	1PC
D	SIDE LID	1PC
E	BOTTOM LIDS	2PCS
F	FRONT LID	1PC

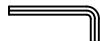
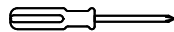
HARDWARE LIST		
ITEM	DESCRIPTION	QTY
1	SCREW M7X65 	8PCS
2	SCREW M4X12 	28PCS
3	SCREW M4X12 	10PCS
4	GAS SPRING 	2PCS
5	BRACKET 	8PCS
6	ALLEN KEY 	1PC
7	SCREWDRIVER 	1PC

STEP 1: Attach side lid (A) and side lid (D) to back lid (C) and front lid (F). As shown below. Insert screws (1) through side lid (A) and side lid (D) into back lid (C) and front lid (F). Do not completely tighten screws at this point.

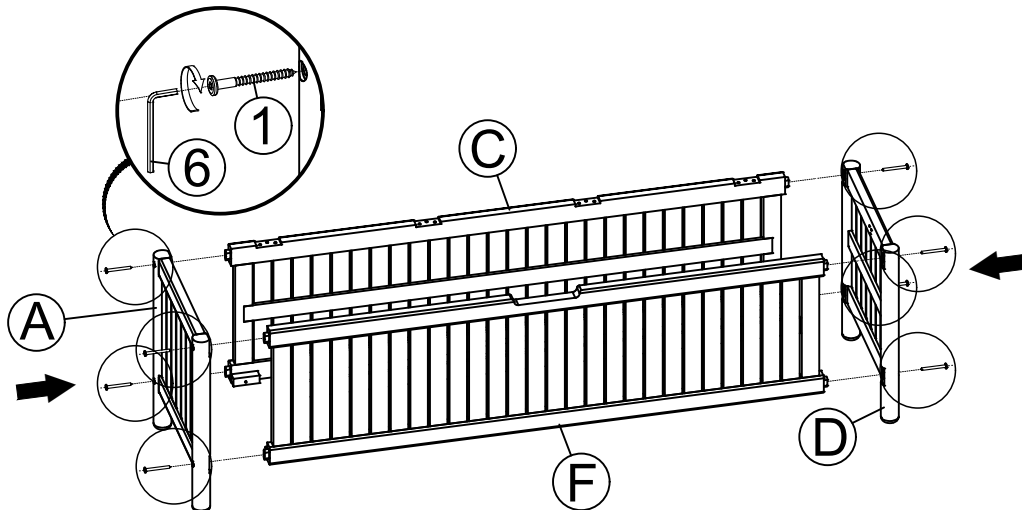

STEP 2: Attach bracket (5) to bottom lids (E). As shown below. Insert screws (2) through bracket (5) into bottom lids (E). Do not completely tighten screws at this point.

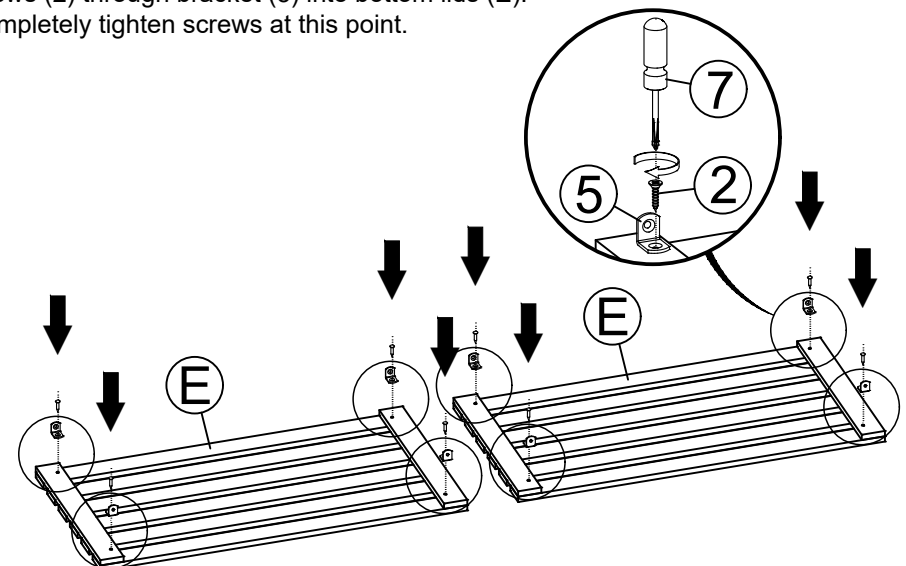

ASSEMBLY INSTRUCTIONS GLBELSBS

Read these instructions and follow steps carefully to ensure you assemble the product correctly and avoid damages. Check that all parts and hardware have been provided before assembling the product. Place all contents on a clean, soft-flat surface to avoid scratching the product.

⚠ CAUTION:

Only tighten bolts to 80% at first. Once all parts have been assembled, fully tighten all hardware.







To prevent damage to threads, do not use a power tool and do not overtighten bolts.

Use two people to lift and turn the product when assembling.

Do not attempt with only one person and do not roll onto legs.

Keep all hardware and small parts away from children.

PART LIST		
ITEM	DESCRIPTION	QTY
A	SIDE LID	1PC
B	TOP LID	1PC
C	BACK LID	1PC
D	SIDE LID	1PC
E	BOTTOM LIDS	2PCS
F	FRONT LID	1PC

HARDWARE LIST		
ITEM	DESCRIPTION	QTY
1	SCREW M7X65 	8PCS
2	SCREW M4X12 	28PCS
3	SCREW M4X12 	10PCS
4	GAS SPRING 	2PCS
5	BRACKET 	8PCS
6	ALLEN KEY 	1PC
7	SCREWDRIVER 	1PC



STEP 3: Attach bottom lids (E) and bracket (5) to back lid (C) and front lid (F). As shown below. Insert screws (2) through bracket (5) into back lid (C) and front lid (F). Do not completely tighten screws at this point.

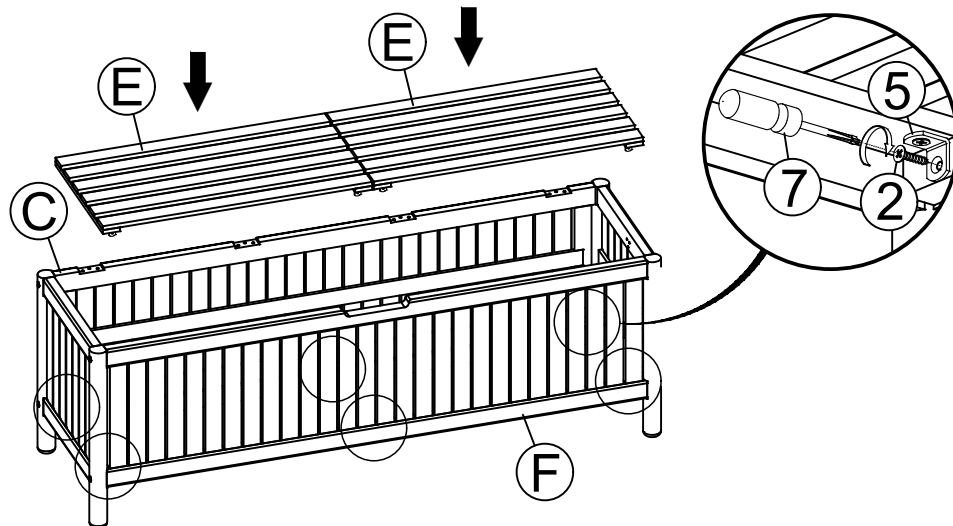

STEP 4: Attach top lid (B) with butt hinge to back lid (C). As shown below. Insert screws (2) through butt hinge of top lid (B) into back lid (C). Do not completely tighten screws at this point.

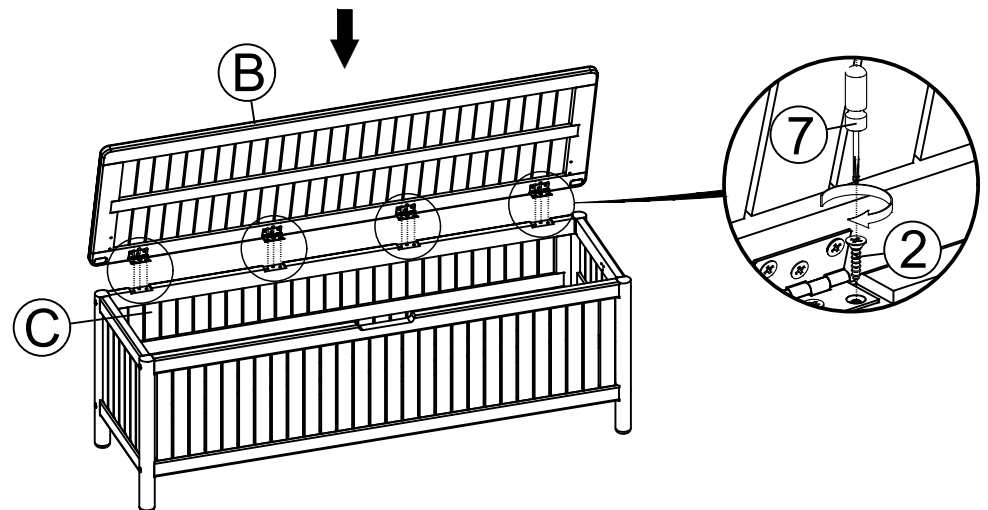

ASSEMBLY INSTRUCTIONS GLBELSBS

Read these instructions and follow steps carefully to ensure you assemble the product correctly and avoid damages. Check that all parts and hardware have been provided before assembling the product. Place all contents on a clean, soft-flat surface to avoid scratching the product.

⚠ CAUTION:

Only tighten bolts to 80% at first. Once all parts have been assembled, fully tighten all hardware.







To prevent damage to threads, do not use a power tool and do not overtighten bolts.

Use two people to lift and turn the product when assembling.

Do not attempt with only one person and do not roll onto legs.

Keep all hardware and small parts away from children.

PART LIST		
ITEM	DESCRIPTION	QTY
A	SIDE LID	1PC
B	TOP LID	1PC
C	BACK LID	1PC
D	SIDE LID	1PC
E	BOTTOM LIDS	2PCS
F	FRONT LID	1PC

HARDWARE LIST		
ITEM	DESCRIPTION	QTY
1	SCREW M7X65 	8PCS
2	SCREW M4X12 	28PCS
3	SCREW M4X12 	10PCS
4	GAS SPRING 	2PCS
5	BRACKET 	8PCS
6	ALLEN KEY 	1PC
7	SCREWDRIVER 	1PC



STEP 5: Attach butt hinge of gas spring (4) to top lid (B) and side lid (A) side lid (D). As shown below. Insert screws (3) through butt hinge of gas spring (4) into top lid (B) and side lid (A) side lid (D). Do not completely tighten screws at this point.

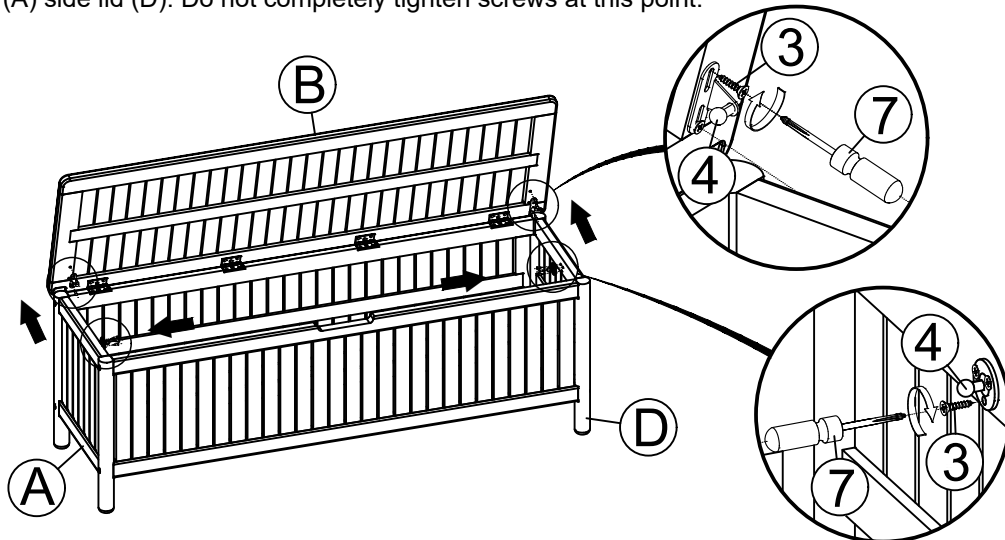

STEP 6: Attach gas spring (4) to butt hinge. As shown below.

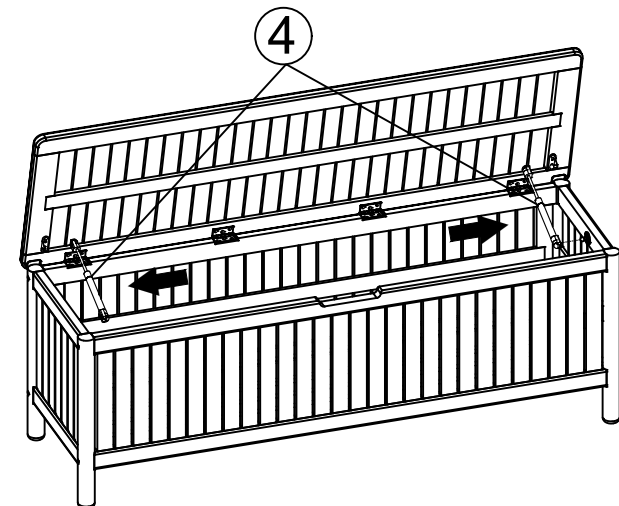

ASSEMBLY INSTRUCTIONS GLBELSBS

Read these instructions and follow steps carefully to ensure you assemble the product correctly and avoid damages. Check that all parts and hardware have been provided before assembling the product. Place all contents on a clean, soft-flat surface to avoid scratching the product.

⚠ CAUTION:

Only tighten bolts to 80% at first. Once all parts have been assembled, fully tighten all hardware.





To prevent damage to threads, do not use a power tool and do not overtighten bolts.

Use two people to lift and turn the product when assembling.

Do not attempt with only one person and do not roll onto legs.

Keep all hardware and small parts away from children.

PART LIST		
ITEM	DESCRIPTION	QTY
A	SIDE LID	1PC
B	TOP LID	1PC
C	BACK LID	1PC
D	SIDE LID	1PC
E	BOTTOM LIDS	2PCS
F	FRONT LID	1PC

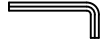
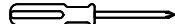
HARDWARE LIST		
ITEM	DESCRIPTION	QTY
1	SCREW M7X65 	8PCS
2	SCREW M4X12 	28PCS
3	SCREW M4X12 	10PCS
4	GAS SPRING 	2PCS
5	BRACKET 	8PCS
6	ALLEN KEY 	1PC
7	SCREWDRIVER 	1PC



STEP 7: Place the assembled cushion box upright on a level surface. Ensure the box legs are aligned & level, then fully tighten all screw using allen key (6) and screwdriver (7). Your cushion box is now ready for use.

