

ASSEMBLY INSTRUCTIONS GLOVLDT

"Read these instructions and follow steps carefully to ensure you assemble the product correctly and avoid damages. Check that all parts and hardware have been provided before assembling the product. Place all contents on a clean, soft-flat surface to avoid scratching the product."

⚠️ "CAUTION:

Only tighten bolts to 80% at first. Once all parts have been assembled, fully tighten all hardware.



To prevent damage to threads, do not use a power tool and do not overtighten bolts.

Use two people to lift and turn the product when assembling.

Do not attempt with only one person and do not roll onto legs.

Keep all hardware and small parts away from children."

PART LIST		
ITEM	DESCRIPTION	QTY
A	FRAME ROUND TOP	2PCS
B	FRAME ROUND BOTTTOM	2PCS
C	LEG FRAMES	8PCS
D	BAR TOP 1	2PCS
E	BAR TOP 2	2PCS
F	TABLE TOP	1PC

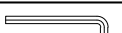
HARDWARE LIST		
ITEM	DESCRIPTION	QTY
1	BOLT M6 x 35 	32PCS
2	BOLT M6 x 65 	16PCS
3	SCREW M6 x 45 	16PCS
4	ALLEN KEY 4 	2PCS



STEP 1: Attach leg frames (C) to frame round top (A) .

Insert caps (1) into leg frames (C), Then insert bolts (1) through frame round top (A) into leg frames (C) as shown below. Tighten with allen key (4).

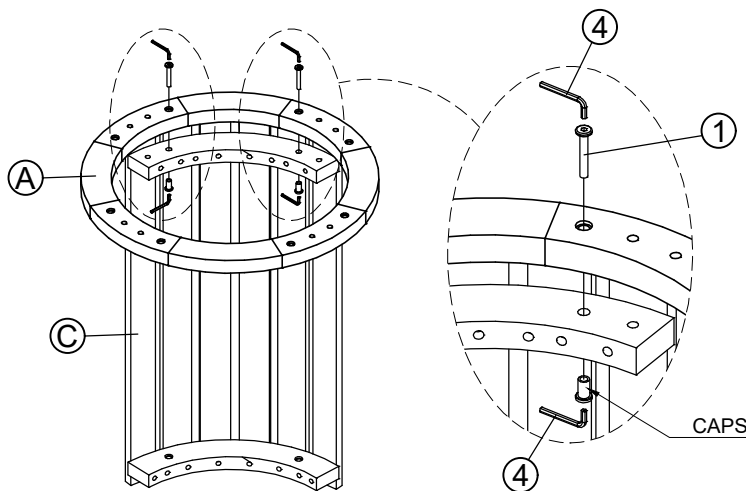

STEP 2: Attach frame round bottom (B) to leg frames (C).

Insert caps (1) into leg frames (C), Then insert bolts (1) through frame round bottom (B) into leg frames (C) as shown below. Tighten with allen key (4).

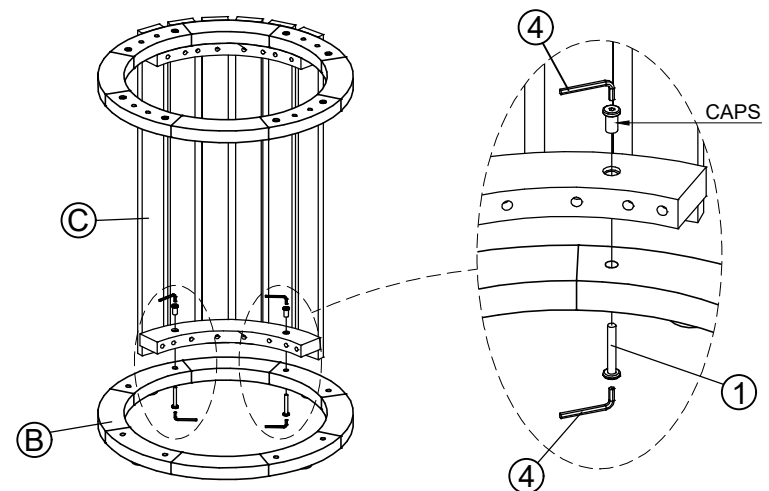

ASSEMBLY INSTRUCTIONS GLOVLDT

"Read these instructions and follow steps carefully to ensure you assemble the product correctly and avoid damages. Check that all parts and hardware have been provided before assembling the product. Place all contents on a clean, soft-flat surface to avoid scratching the product."

⚠️ "CAUTION:

Only tighten bolts to 80% at first. Once all parts have been assembled, fully tighten all hardware.



To prevent damage to threads, do not use a power tool and do not overtighten bolts.

Use two people to lift and turn the product when assembling.

Do not attempt with only one person and do not roll onto legs.

Keep all hardware and small parts away from children."

PART LIST		
ITEM	DESCRIPTION	QTY
A	FRAME ROUND TOP	2PCS
B	FRAME ROUND BOTTTOM	2PCS
C	LEG FRAMES	8PCS
D	BAR TOP 1	2PCS
E	BAR TOP 2	2PCS
F	TABLE TOP	1PC

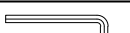
HARDWARE LIST		
ITEM	DESCRIPTION	QTY
1	BOLT M6 x 35 	32PCS
2	BOLT M6 x 65 	16PCS
3	SCREW M6 x 45 	16PCS
4	ALLEN KEY 4 	2PCS



STEP 3: Attach leg frames (C) to frame round top (A) and frame round bottom (B). Repeat the process in the same order for the remaining pins

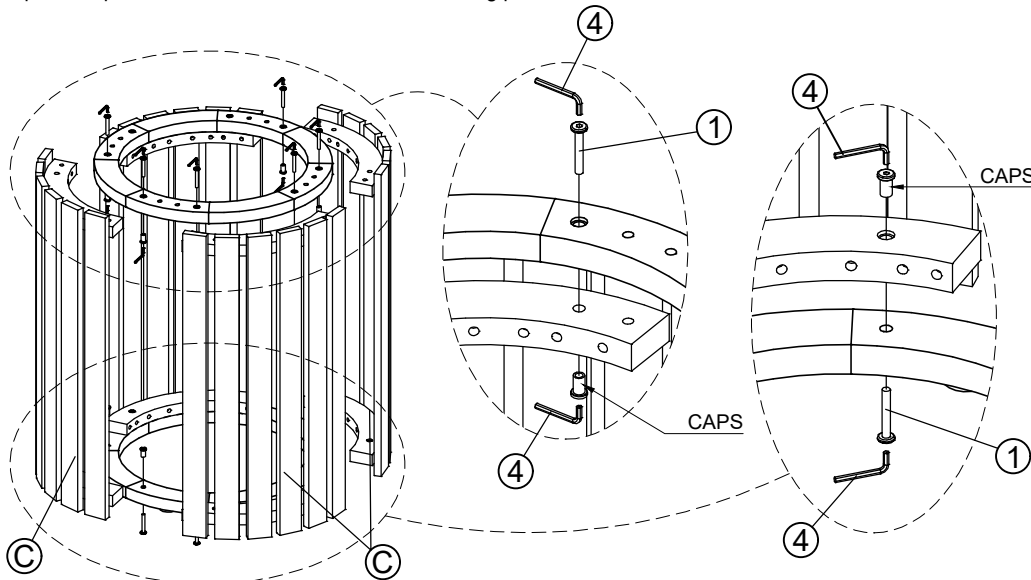

STEP 4: Attach bar top 1 (D) and bar top 2 (E) to frame round top (A). Insert caps (2) into leg frames (C), Then insert bolts (2) through bar top 1 (D) into leg frames (C), tighten with allen key (4). Insert caps (2) into leg frames (C), Then insert bolts (2) through bar top 2 (E) into leg frames (C) as shown below Tighten with allen key (4).

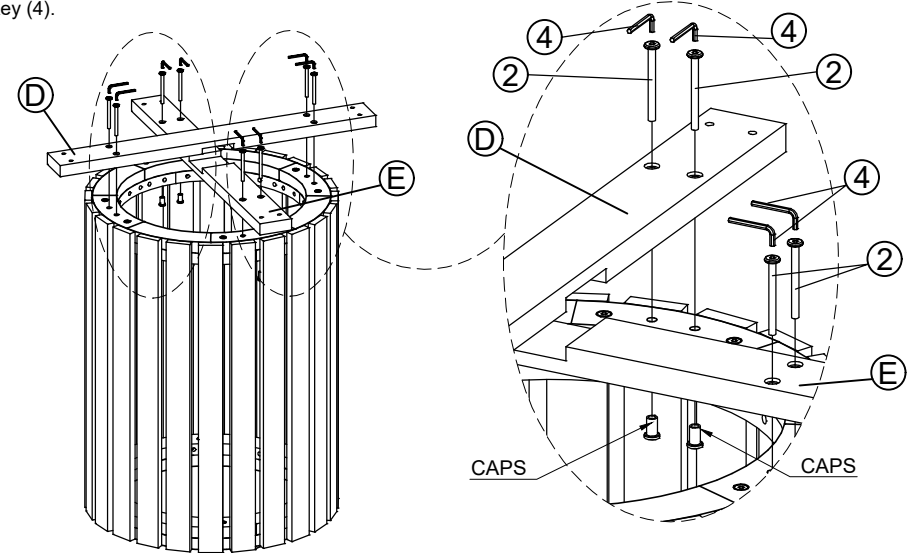

ASSEMBLY INSTRUCTIONS GLOVLDT

"Read these instructions and follow steps carefully to ensure you assemble the product correctly and avoid damages. Check that all parts and hardware have been provided before assembling the product. Place all contents on a clean, soft-flat surface to avoid scratching the product."

⚠️ "CAUTION:

Only tighten bolts to 80% at first. Once all parts have been assembled, fully tighten all hardware.





To prevent damage to threads, do not use a power tool and do not overtighten bolts.

Use two people to lift and turn the product when assembling.

Do not attempt with only one person and do not roll onto legs.

Keep all hardware and small parts away from children."

PART LIST		
ITEM	DESCRIPTION	QTY
A	FRAME ROUND TOP	2PCS
B	FRAME ROUND BOTTTOM	2PCS
C	LEG FRAMES	8PCS
D	BAR TOP 1	2PCS
E	BAR TOP 2	2PCS
F	TABLE TOP	1PC

HARDWARE LIST		
ITEM	DESCRIPTION	QTY
1	BOLT M6 x 35 	32PCS
2	BOLT M6 x 65 	16PCS
3	SCREW M6 x 45 	16PCS
4	ALLEN KEY 4 	2PCS



STEP 5: Attach leg frames to table top (F)
Insert Screw (3) through bar top 1 (D) into table top (F). Insert Screw (3) through bar top 2 (E) into table top (F) as shown below. Tighten with allen key (4).

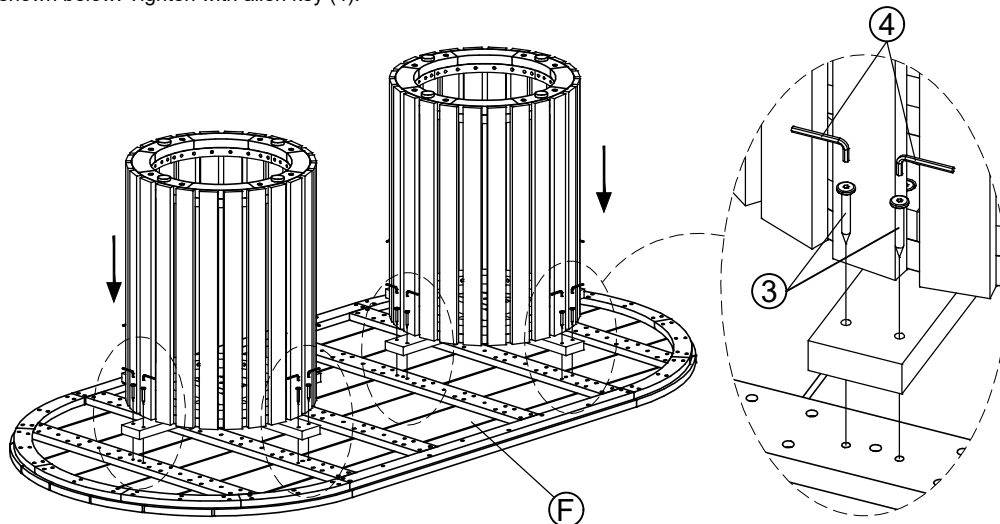

STEP 6: Place the assembled table upright on a level surface. Ensure all table legs are aligned & level, then fully tighten all bolts & screw using allen key (4).
Your table is now ready for use.

