

ASSEMBLY INSTRUCTIONS















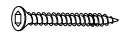



PAGE: 1/6

MODEL : UG 0275

Before you begin, please follow assembly instructions carefully, then follow them step by step.

Read instruction carefully . See Furniture Parts list and Hardware List for guidance . Be sure you have all parts before you start assembling . Place and assemble furniture on a clean flat soft surface , such as carpet or rug to prevent being scratched .

PART LIST		QTY
1	TOP PANEL	1 PC
2	BOTTOM PANEL	1 PC
3	SIDE PANEL (L)	1 PC
4	SIDE PANEL (R)	1 PC
5	CENTER PANEL-UP	4 PCS
6	CENTER PANEL-DOWN	1 PC
7	MIDDLE PANEL-1	1 PC
8	MIDDLE PANEL-2	1 PC
9	SLIDING DOOR	2 PCS
10	BACK PANEL	1 PC
11	DOOR BONE	2 PCS
12	LEG	4 PCS

HARDWARE				
A	MINI FIX	A1  A2  A3 		22 SETS
B	M8 X 30MM WOOD DOWEL			36 PCS
C	M8 X 25MM WOOD DOWEL			4 PCS
D	M6 X 50MM CSK CAP WOOD SCREW			14 PCS
E	ALLEN KEY M4			1 PC
F	M4 X 25MM C.B SCREW			6 PCS
G	M3 X 12MM C.B SCREW			16 PCS
H	5/8 NAIL			38 PCS
I	JCBC Screw M6 x 70			8 PCS
J	SPRING WASHER M6			8 PCS
K	FLAT WASHER M6			8 PCS
L	U 480 ROLLER	L1  L2 		4 PCS
M	TIPPING PACK WITH AI	M1  M2  M3  M4 		2 SETS
N	WALL PLUG (NOT INCLUDED)			-

SELF-PREPARED TOOLS: Tools below are NOT included in package.



SCREWDRIVER



HAMMER

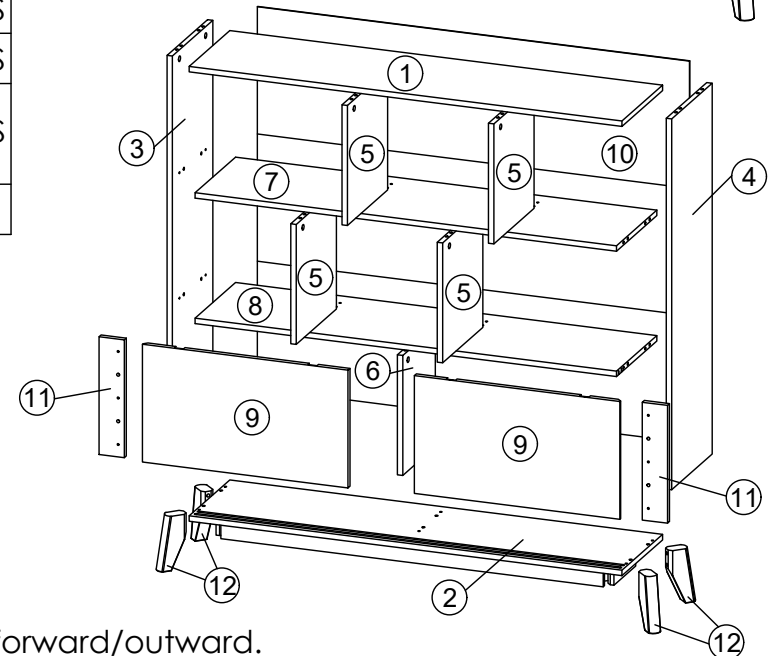
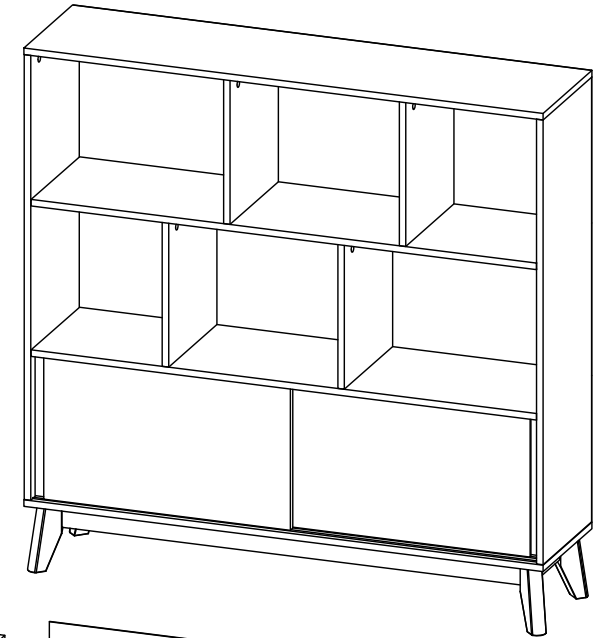

Reminder:

Please ensure that all surfaces and edges with colours/laminations are facing forward/outward.

ASSEMBLY INSTRUCTIONS

PAGE: 2/6

MODEL : UG 0275

STEP 1

- Insert hardware **A1** onto panel (3) and (4).
(Repeat 4 times.)
- Insert hardware **A2** onto panel (1), (3) and (4).
(Repeat 16 times.)
- Insert hardware **B** onto panel (3) and (4).
(Repeat 8 times.)

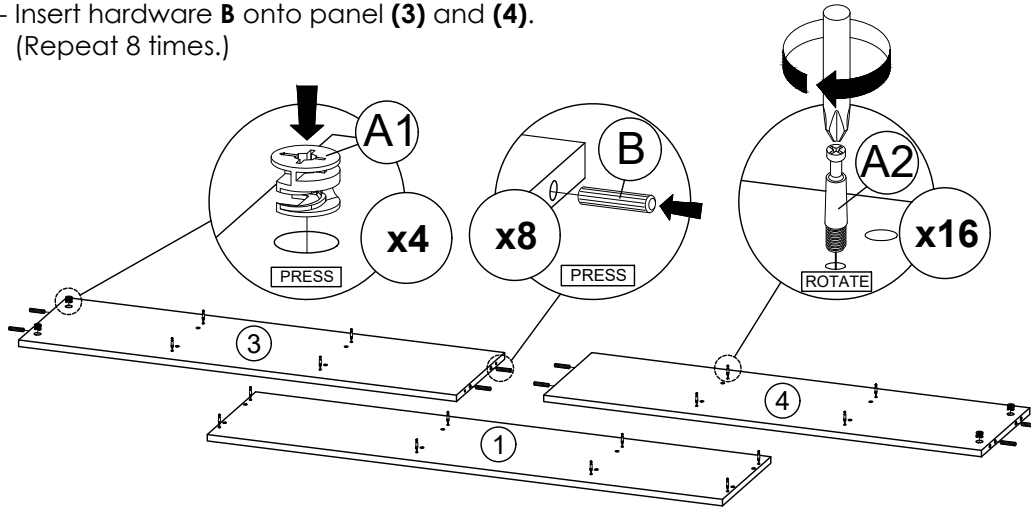

STEP 2

- Insert hardware **A1** onto panel (5) and (6).
(Repeat 10 times.)
- Insert hardware **B** onto panel (5) and (6).
(Repeat 20 times.)

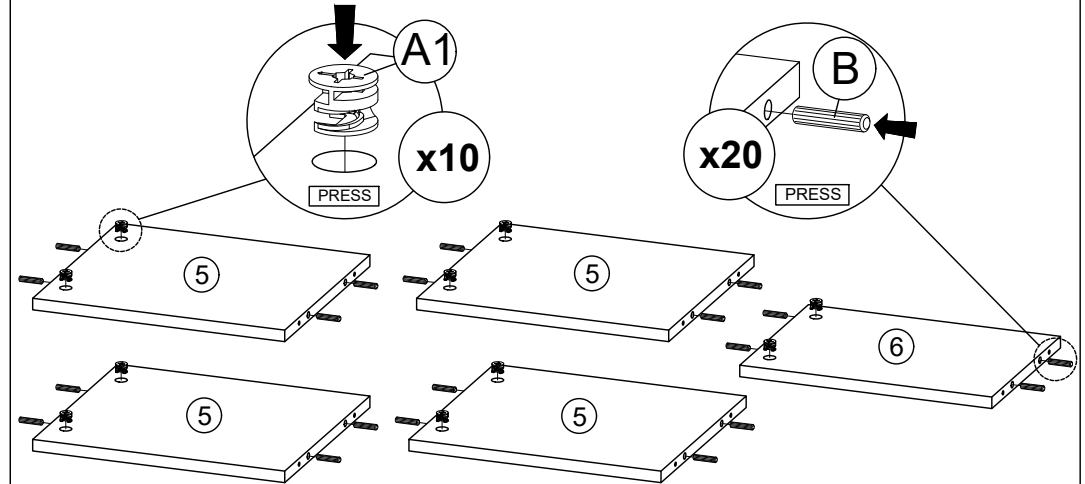

STEP 3

- Insert hardware **A1** and **B** onto panel (7) and (8).
(Repeat 8 times.)
- Insert hardware **A2** onto panel (7) and (8).
(Repeat 6 times.)

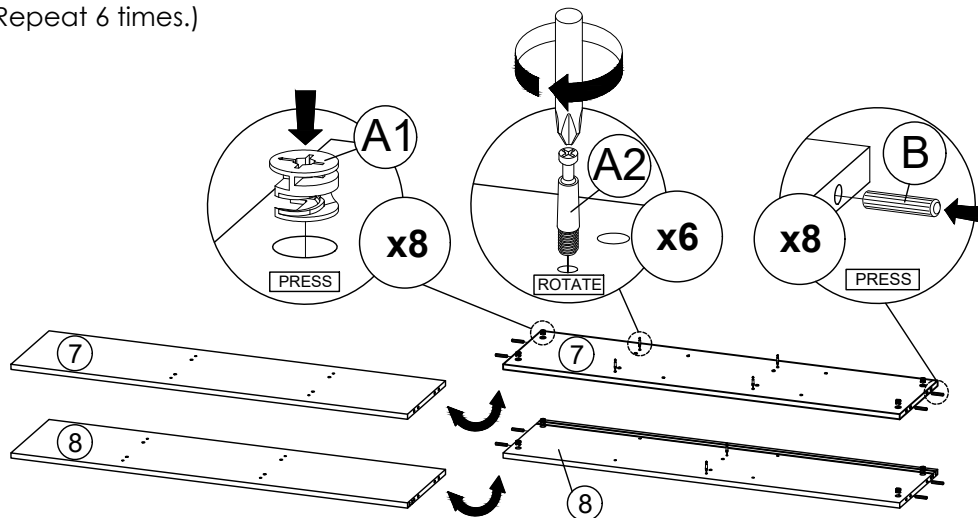

STEP 4

- Attach panel (5) and (6) to panel (7) and (8).
- Insert all hardware **A2** into **A1**.
- Rotate all **A1** until tight.
- Apply **A3** onto all **A1**.
(Repeat 6 times.)



OR

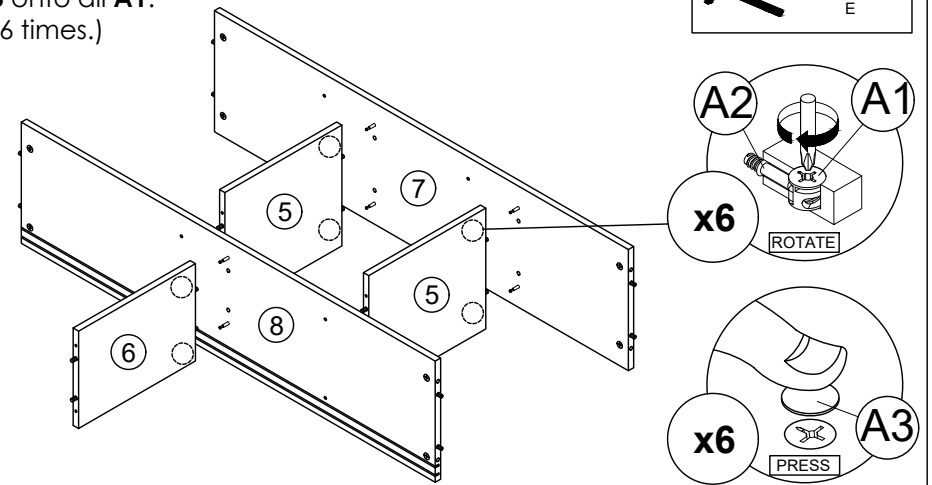

* In this step hardware **A1**, **A2** and **B** are pre-inserted.

ASSEMBLY INSTRUCTIONS

PAGE: 3/6

MODEL : UG 0275

STEP 5

- Connect panel (5) to panel (7) and (8) by using hardware **D** and **E**.
(Repeat 8 times.)

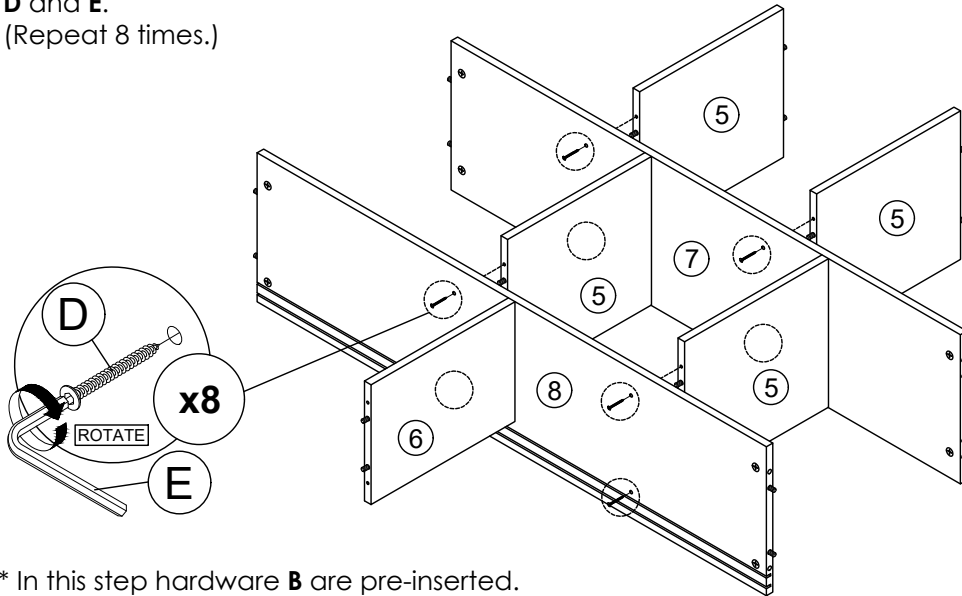

* In this step hardware **B** are pre-inserted.

STEP 6

- Connect **A2** from panel (3) into **A1** in panel (7) and (8).
- Rotate all **A1** until tight.
- Apply **A3** onto all **A1**.
(Repeat 4 times.)



OR

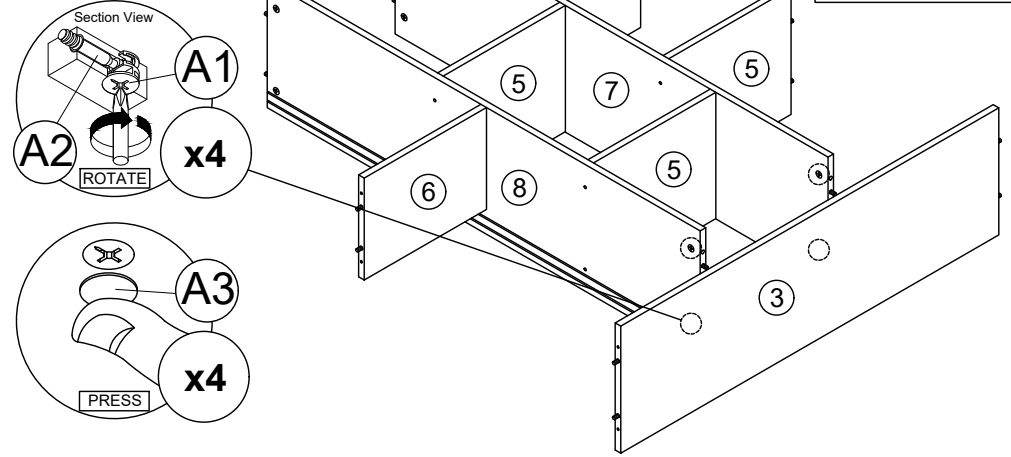

* In this step hardware **A1**, **A2** and **B** are pre-inserted.

STEP 7

- Connect **A2** from panel (4) into **A1** in panel (7) and (8).
- Rotate all **A1** until tight.
- Apply **A3** onto all **A1**.
(Repeat 4 times.)



OR

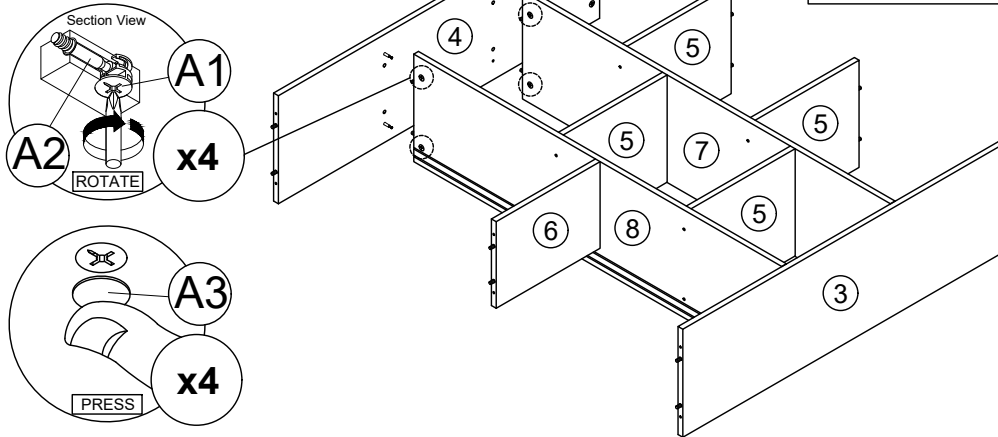
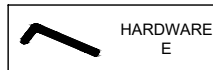

* In this step hardware **A1**, **A2** and **B** are pre-inserted.

STEP 8

- Connect **A2** from panel (1) into **A1** in panel (3), (4) and (5).
- Rotate all **A1** until tight.
- Apply **A3** onto all **A1**.
(Repeat 8 times.)

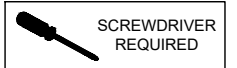

OR

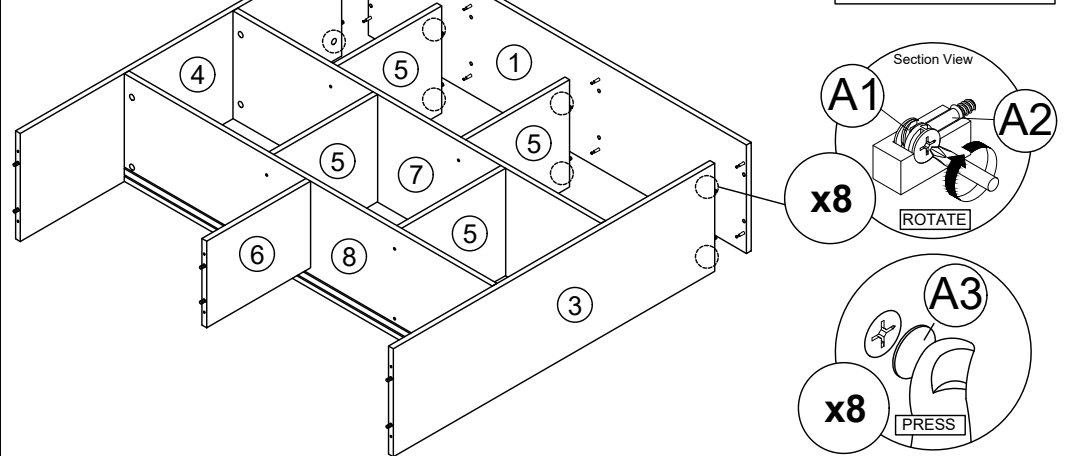

* In this step hardware **A1**, **A2** and **B** are pre-inserted.

ASSEMBLY INSTRUCTIONS

PAGE: 4/6

MODEL : UG 0275

STEP 9

- Connect panel (2) to panel (3), (4) and (6) by using hardware D and E.
(Repeat 6 times.)

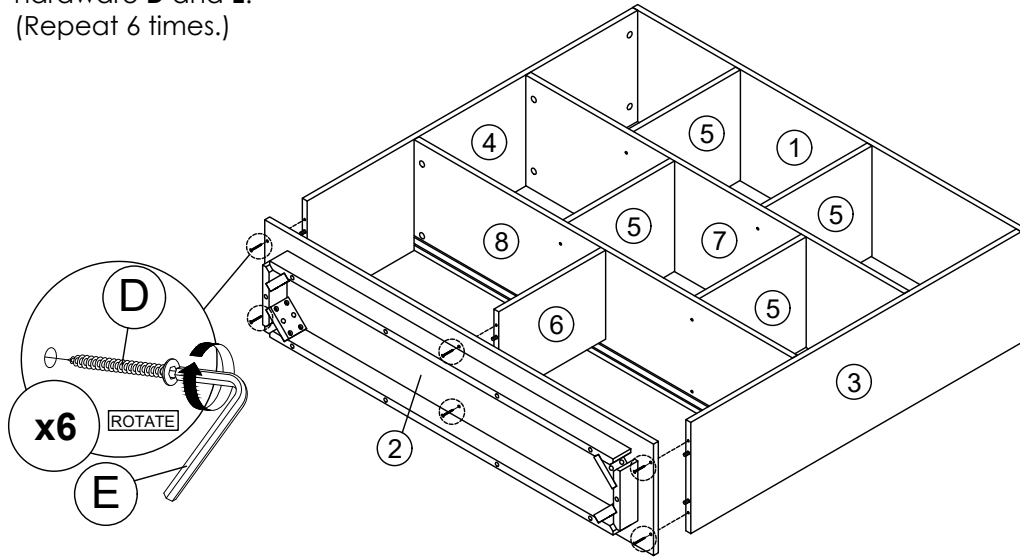

* In this step hardware B are pre-inserted.

STEP 10

- Assemble part (12) into panel (2) by using hardware E, I, J and K.
(Repeat 2 times for each Leg.)

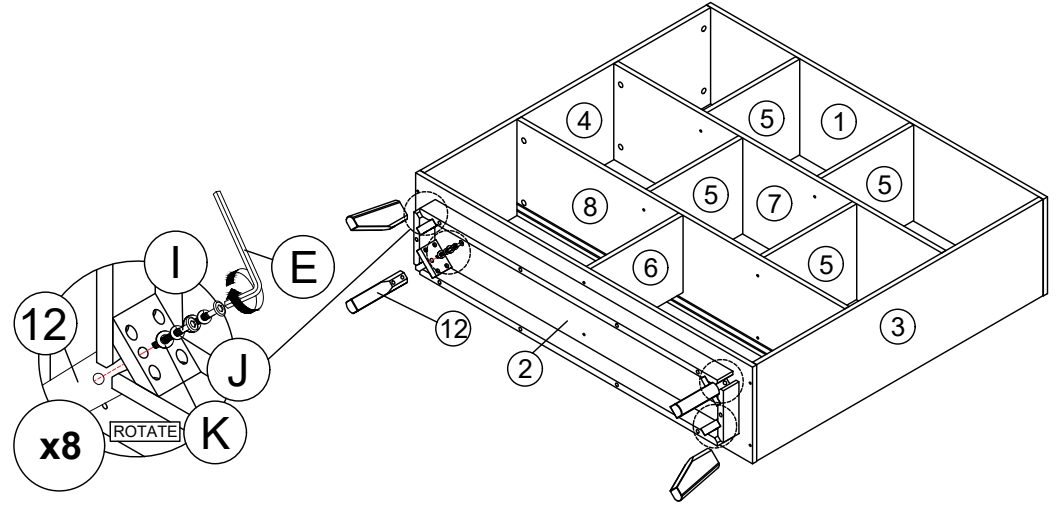

STEP 11

- Hit hardware H into back of panel (10).
(Repeat 38 times.)

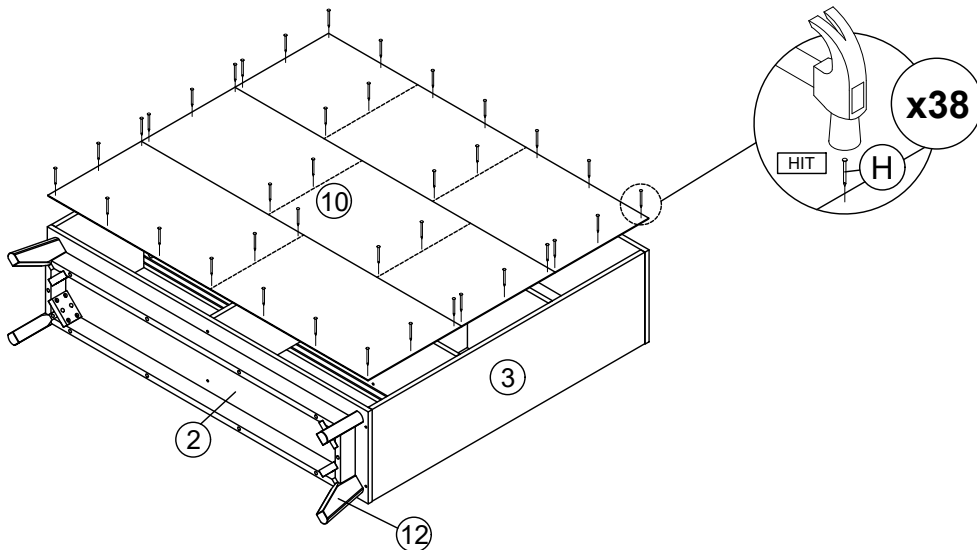

STEP 12

- Insert hardware C onto panel (9).
(Repeat 4 times.)

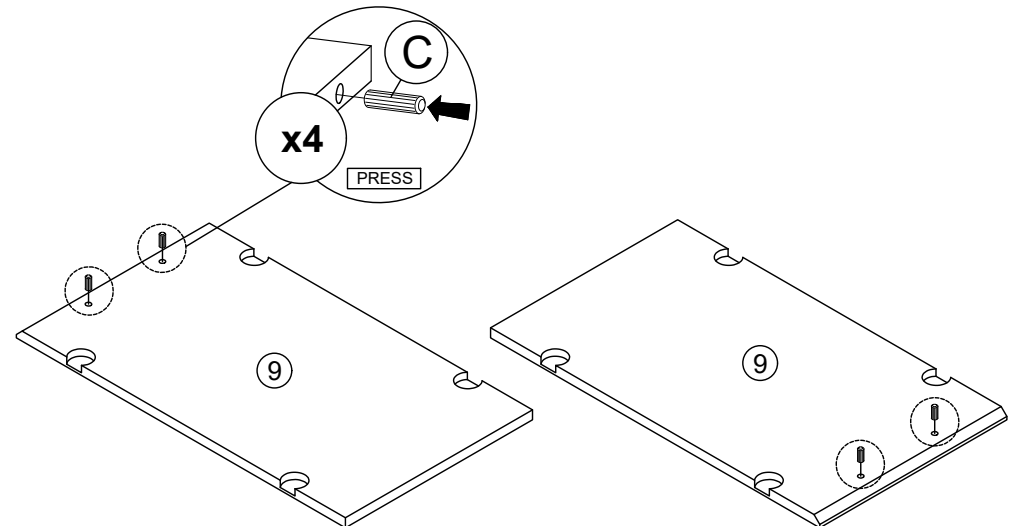

ASSEMBLY INSTRUCTIONS

PAGE: 5/6

MODEL : UG 0275

STEP 13

- Connect panel (11) to panel (9) by using hardware F. (Repeat 6 times.)

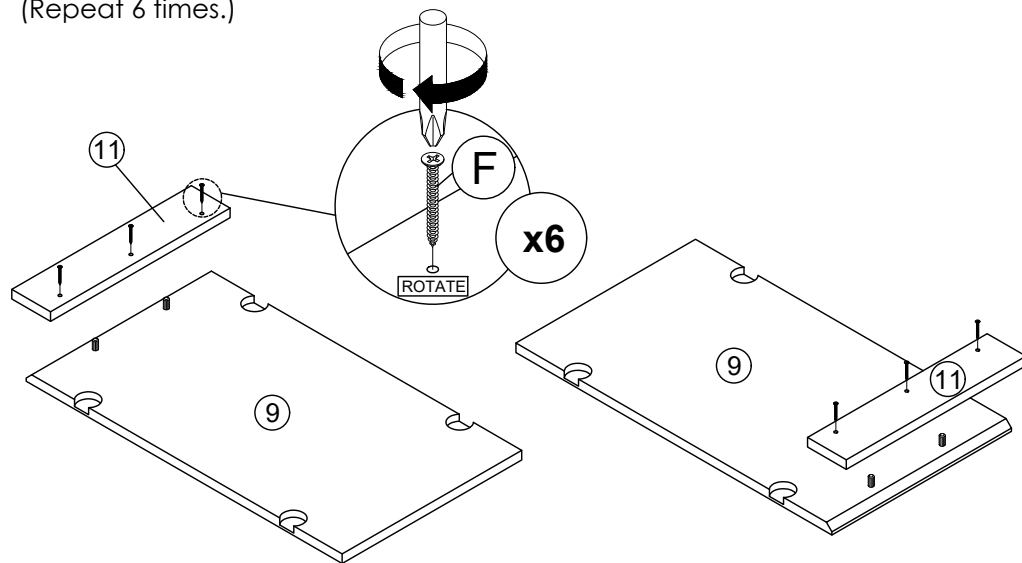

* In this step hardware C are pre-inserted.

STEP 14

- Assemble hardware L1/L2 to two panel (9) with hardware G. (Repeat 2 times for each hardware.)

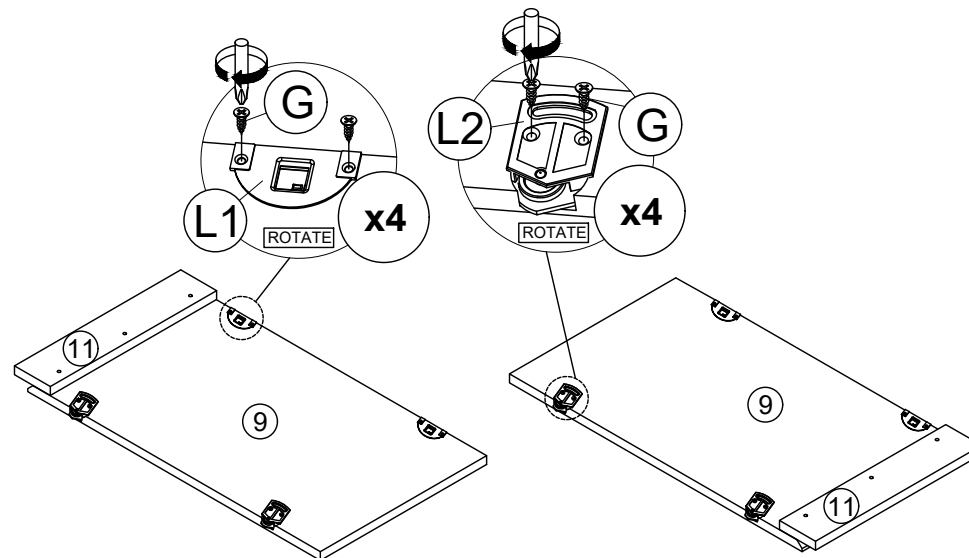

STEP 15

- Put the panel (9) in place. (Repeat 2 times.)

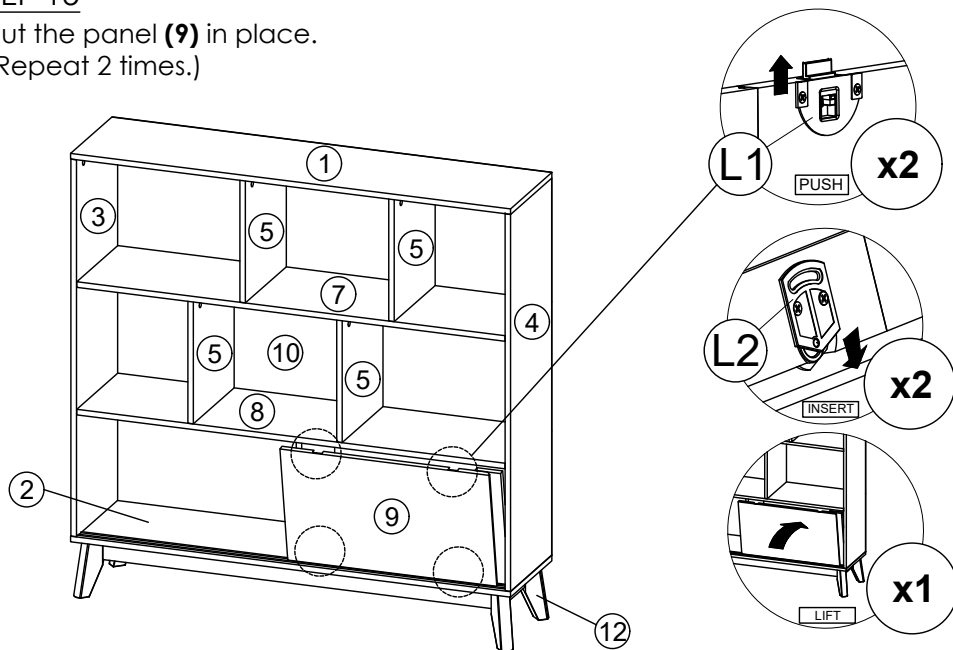

STEP 16

- Put the panel (9) in place. (Repeat 2 times.)

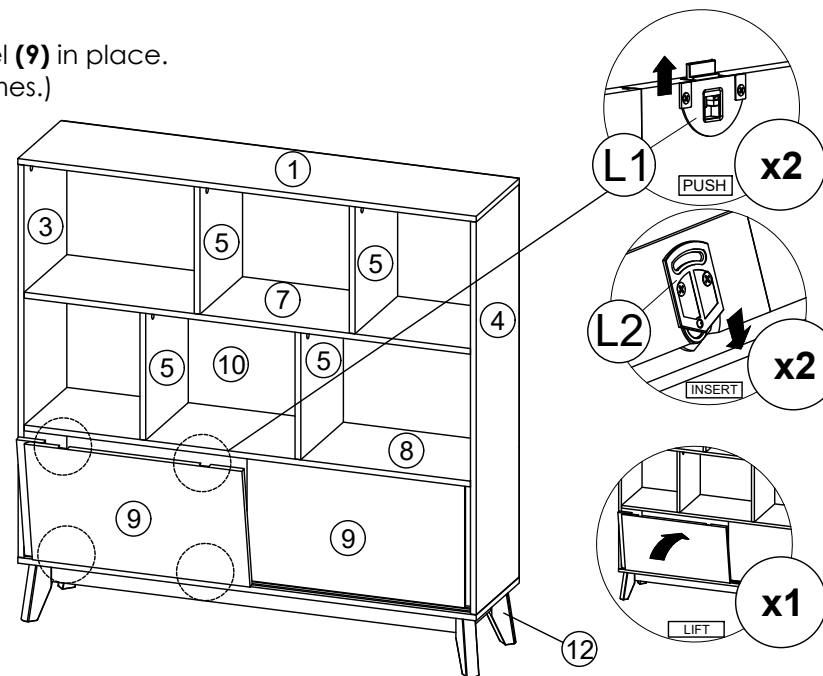

ASSEMBLY INSTRUCTIONS

PAGE: 6/6

MODEL : UG 0275

STEP 17

- Assemble hardware **M1** into panel **(1)** and **(10)** by using hardware **M2**.
(Repeat 2 times.)

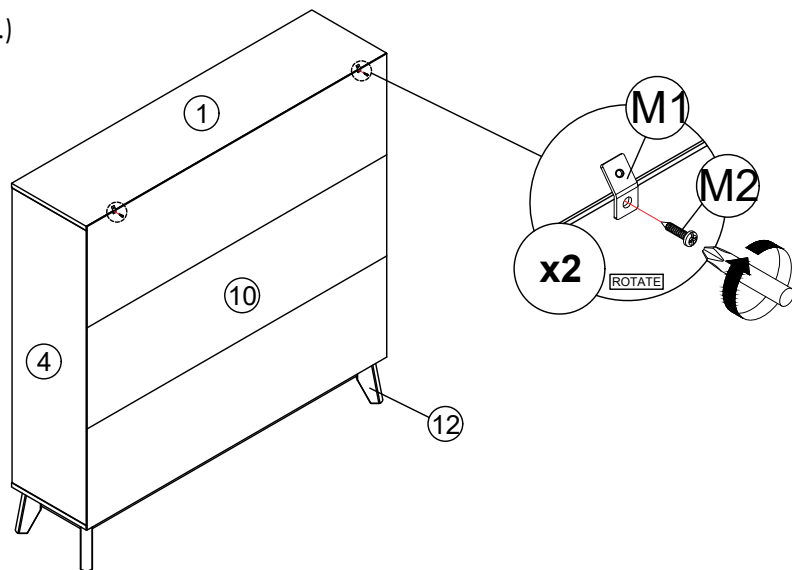

STEP 18

- Mark and use the power drill to drill a hole on the wall.
- Hit hardware **N** into the wall.
(Repeat 2 times.)

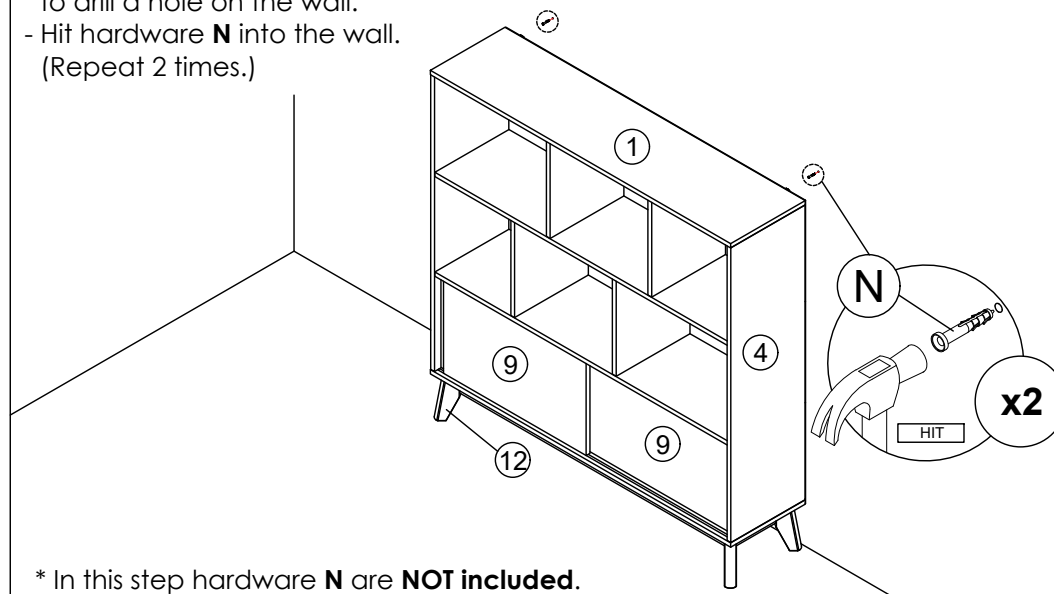

* In this step hardware **N** are **NOT** included.

STEP 19

- Assemble hardware **M1** into **N** by using hardware **M3**.
(Repeat 2 times.)

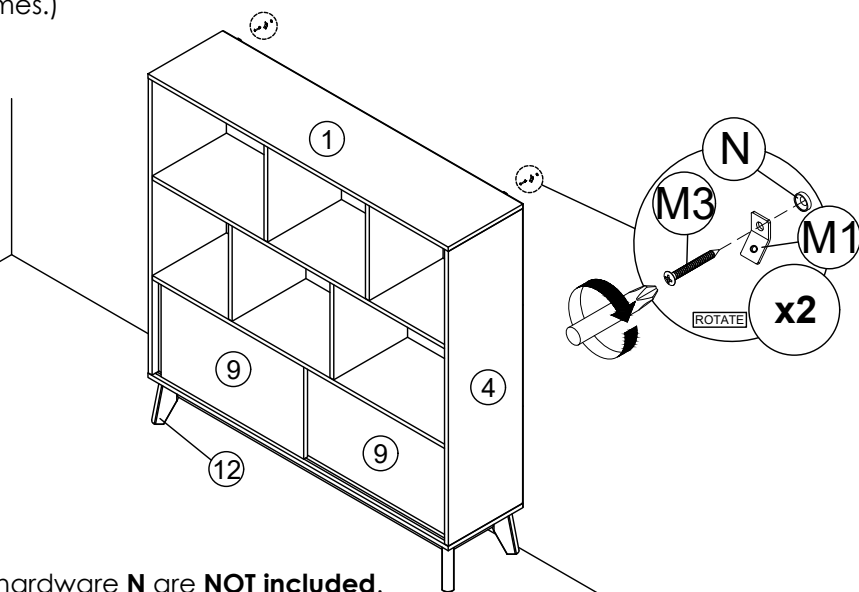

* In this step hardware **N** are **NOT** included.

STEP 20

- Connect both of the hardware **M1** by using hardware **M4**.
- Tighten the hardware **M4**.
(Repeat 2 times.)

