

Linen Fabric Office Chair

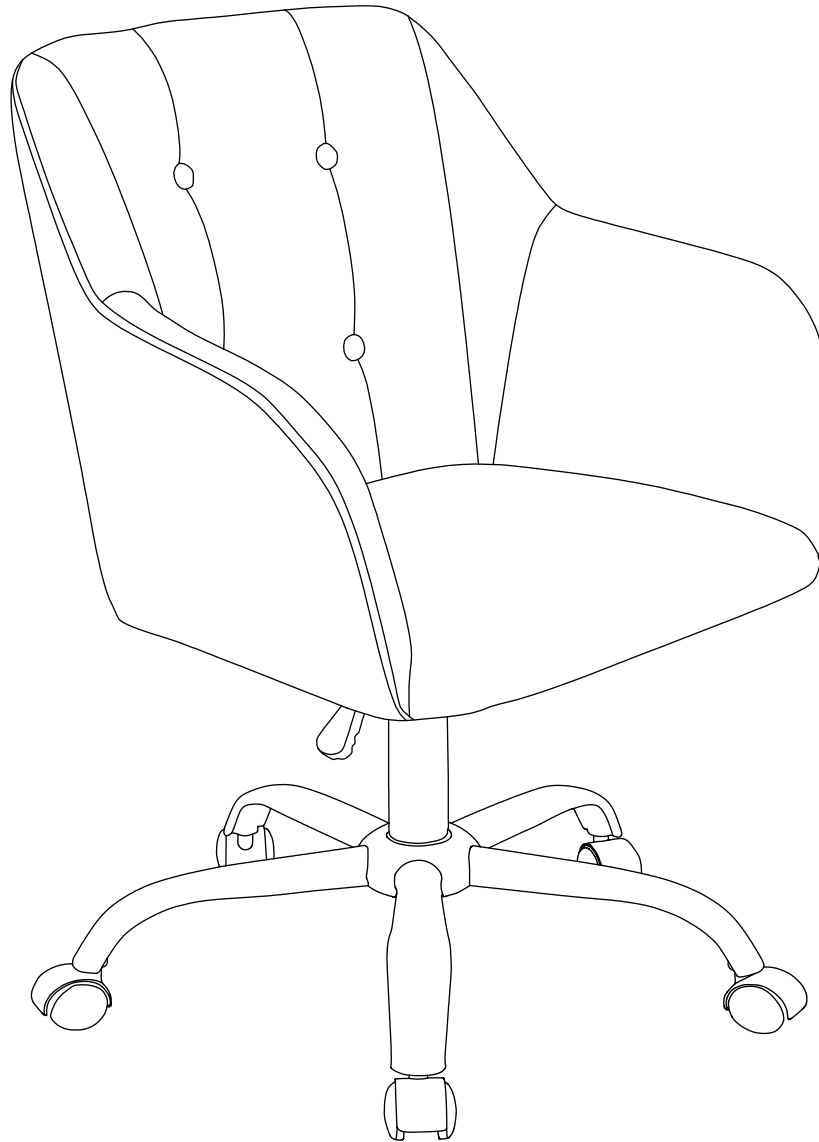

ASSEMBLY AND CARE GUIDE

0.5 HOUR
ASSEMBLY TIME

1 PERSON
REQUIRED FOR ASSEMBLY

1 x 1 m
FLOOR SPACE REQUIRED

SAFETY PRECAUTIONS

PLEASE READ ALL INSTRUCTIONS CAREFULLY BEFORE ASSEMBLING AND USING THE PRODUCT.



1. Please check that all parts are present before you start the assembly of your furniture.
2. For ease and speed of assembly, we recommend that before you commence each step of the assembly, that you identify all the parts required for that step.
3. For larger items, please ensure that you have sufficient space and people to assemble your product safely.
4. We recommend that, where possible, all items are assembled near to the area in which they will be placed in use, to avoid moving the product unnecessarily once assembled.
5. For the protection of your furniture, we recommend that the product is placed on a protected surface during assembly to prevent any damage.
6. During assembly please take care not to over-tighten any fitting, as this may damage the product.
7. Always place the product on a flat, steady and stable surface.
8. Do not stand on the product. Do not use the product as a stepladder.
9. This product is intended for indoor, household use only as it is a non industrial product.

CARE AND CLEANING

- Please periodically check all fittings and re-tighten as necessary.
- To clean your item, please use a damp cloth and wipe clean.
- Never allow any kind of liquid to remain on your furniture. If liquid spills onto the product, please wipe clean as soon as possible.

READ AND SAVE THESE INSTRUCTIONS FOR FUTURE REFERENCE

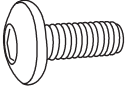
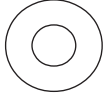
HARDWARE LIST

a		b		c	
4 PCS		4 PCS		1 PC	

PARTS LIST

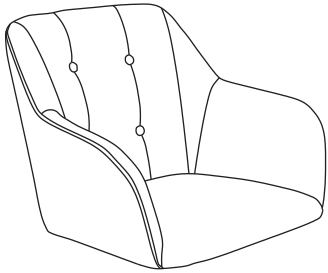

1 1PC

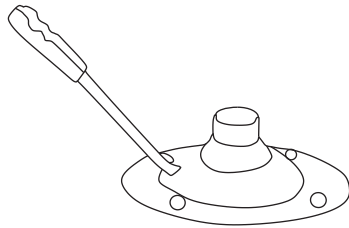

2 - 1 PC

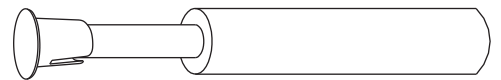

3 - 1 PC

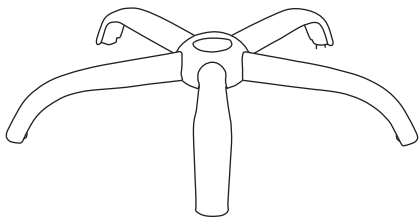

4 - 1 PC



5 - 5 PCS

AFTER SALES SUPPORT

If you have any general enquiries or require spare parts for this product, please contact our nationwide Customer Service Line.

Phone: 1300 777 137

Hours: Monday - Friday 9:00am - 4:30pm (AEST)

Saturday 9:00am - 3:00pm (AEST)

(excluding public holidays)

ASSEMBLY STEPS

STEP 1.

Push castors 5 into wheel base 4.

Lower gas lift 3 into the wheel base 4, as shown.

Note: Take the cap of the gas lift first.

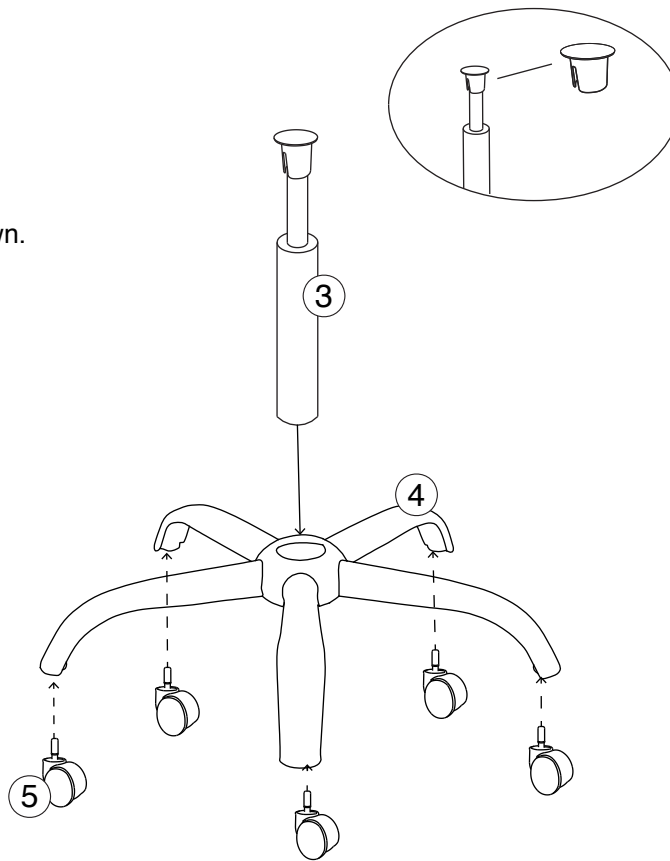

STEP 2.

Fix lift mechanism 2 onto seat 1 using screws (a), washers (b) and allen key (c), as shown.

Note: Ensure lift mechanism 2 is orientated in the correct direction to the front of the chair, as indicated by the sticker.

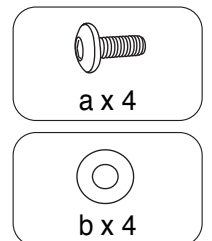
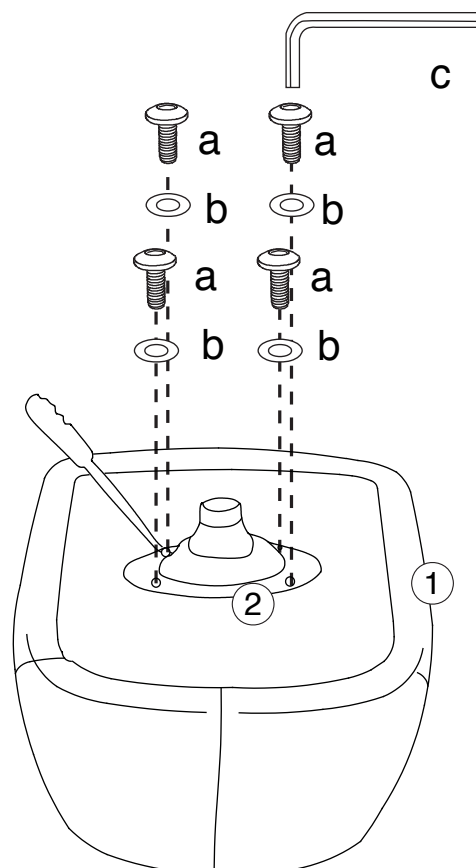

ASSEMBLY STEPS

STEP 3.

Lower assembled seat onto assembled base.

Apply pressure to fix together.

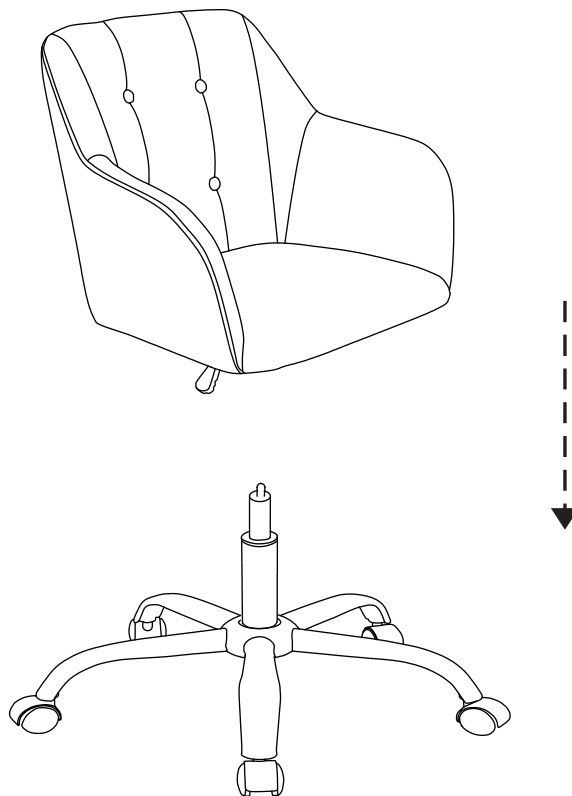

STEP 4.

Please note: Maximum recommended weight is 100kg.

Your office chair is ready for use.

