

CODY BUFFET 3 DRAWER 3 SHELF 1 DOOR

2 hrs

APPROXIMATE ASSEMBLY TIME

2 PERSON ASSEMBLY

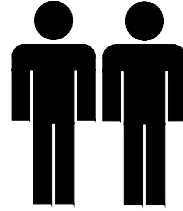

FLOOR AREA
2M x 2M

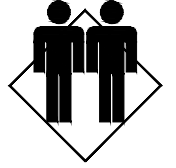

REQUIRED ASSEMBLY SPACE

REQUIRED ASSEMBLY TOOLS

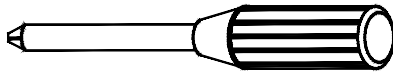

PHILLIPS SCREWDRIVER

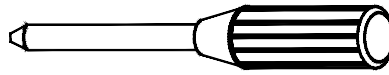

FLAT HEAD SCREWDRIVER

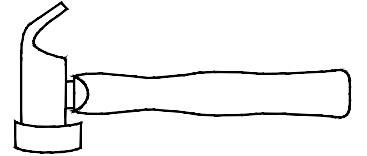

HAMMER

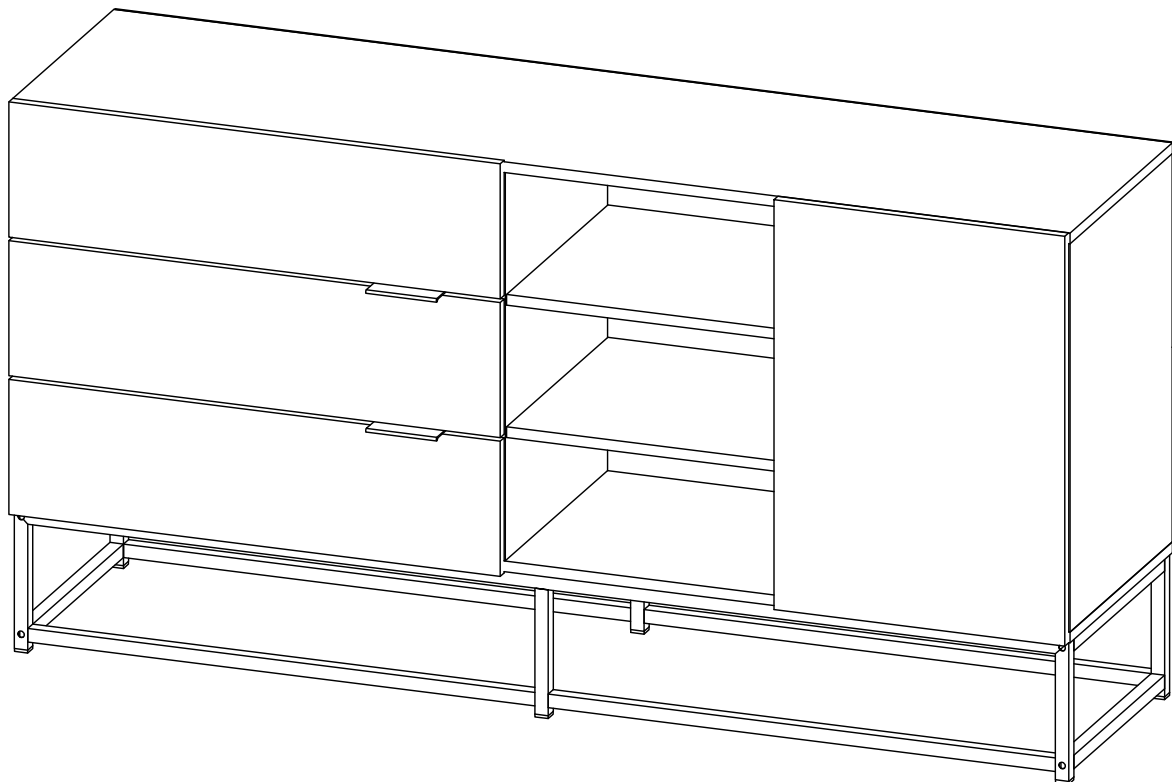

CODY BUFFET 3 DRAWER 3 SHELF 1 DOOR

Tips before you start:

1. Please check that all parts are present before you start the assembly of your furniture.
2. For ease and speed of assembly, we recommend that before you commence each step of the assembly, that you identify all the parts required for that step.
3. For larger items, please ensure that you have sufficient space and people (as indicated on page 1) to assemble your product safely.
4. We recommend that, where possible, all items are assembled near to the area in which they will be placed in use, to avoid moving the product unnecessarily once assembled.
5. For the protection of your furniture, we recommend that the product is placed on a protected surface during assembly to prevent any damage.
6. During assembly please take care not to over-tighten any fittings, as this may damage the product.
7. Always place the product on a flat, steady and stable surface.
8. Do not stand on the product. Do not use the product as a stepladder.
9. This product is intended for indoor, household use only as it is a non-industrial product.
10. Please use caution and care when lifting the product to avoid personal injury and/or product damage.

Care and Maintenance of your Furniture

- ✓ Please periodically check all fittings and re-tighten as necessary.
- ✓ To clean your item, please use a damp cloth and wipe clean.
- ✓ Never allow any kind of liquid to remain on your furniture. Absorption can cause wood to warp or finishes to de-laminate.
- ✓ Please do not place hot items (eg. hot drinks) directly on to the surface.
- ✓ Please do not drag and pull your furniture.

CODY BUFFET 3 DRAWER 3 SHELF 1 DOOR

QUICKFIT

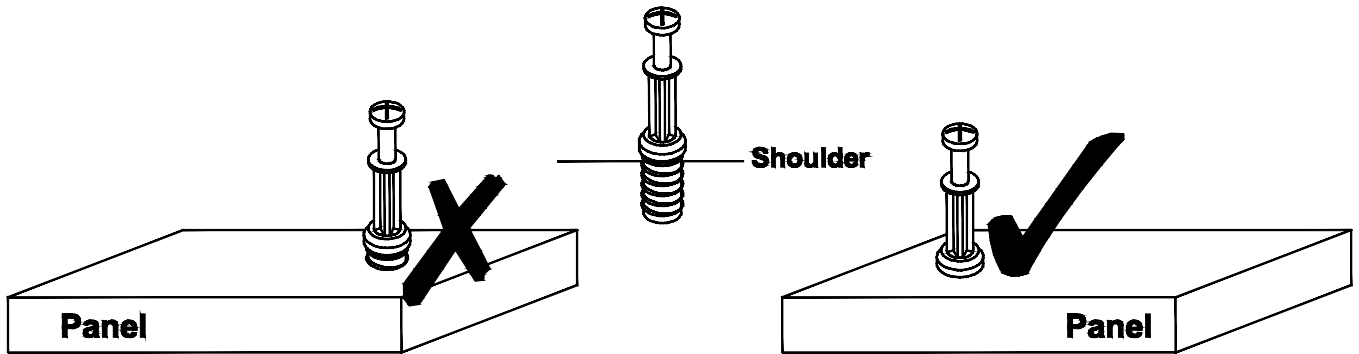

Tighten quickfit until shoulder is flush with panel. Do not overtighten or undertighten.

CAM LOCK

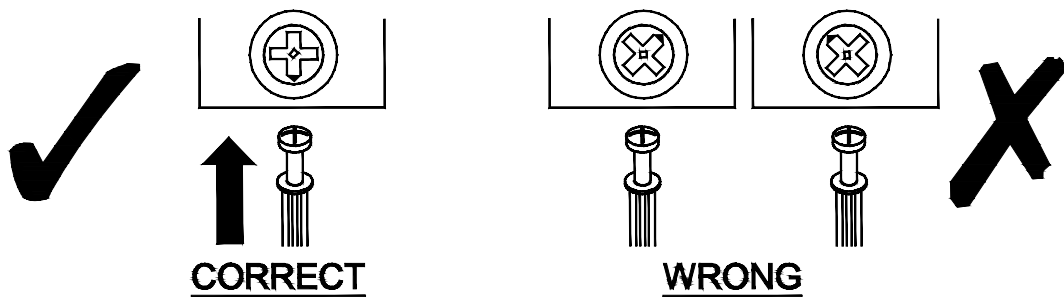

When fitting cam lock, ensure starting position is correct before you insert connecting quickfit.

Quickfit head should be in the centre of the cam lock when the two panels are joined.

Cam lock should be inserted before quickfit.

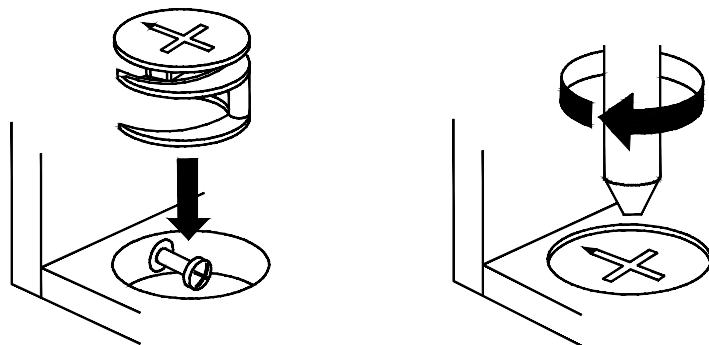

Turn cam lock clockwise to tighten.

CODY BUFFET 3 DRAWER 3 SHELF 1 DOOR

HARDWARE LIST



10 x A1
Cam
Lock

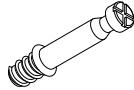

10 x A2
Quickfit
Screw



10 x A3
Cover

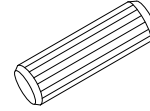

18 x B
Wooden
Dowel

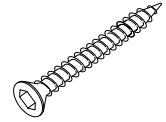

8 x C
Cap Wood
Screw

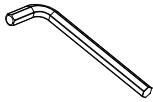

1 x D
Allen
Key



4 x E
Screw



54 x F
Screw



24 x G
Screw

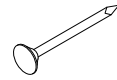

58 x H
Nail

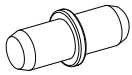

16 x I
Metal Shelf
Support



8 x J
Bolt

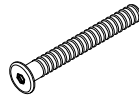

8 x K
Bolt

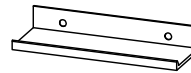

2 x L
Handle

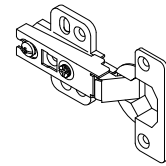

2 x M
Hinge

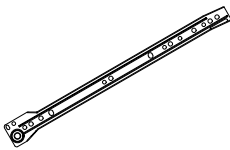

6 x N1
Drawer
Slide

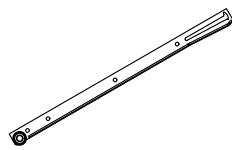

6 x N2
Drawer
Slide

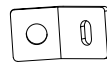

4 x O1
Wall
Support



2 x O2
Screw

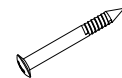



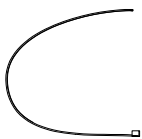



2 x O3
Screw

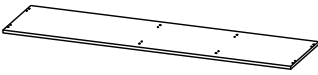

2 x O4
Cable
Tie

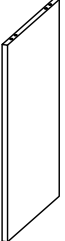
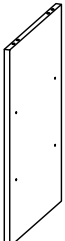
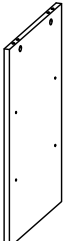
CODY BUFFET 3 DRAWER 3 SHELF 1 DOOR

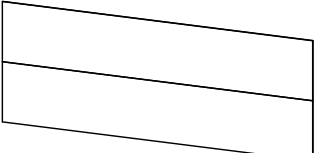
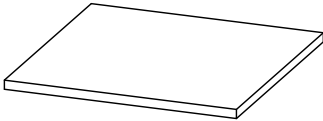
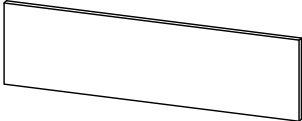
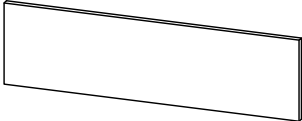
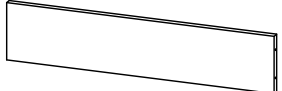
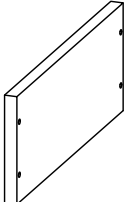
PART LIST

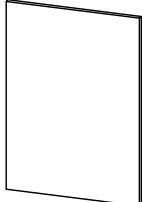
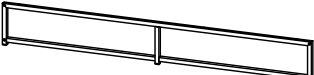
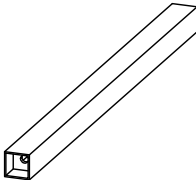
			
1 1 PC	2 1 PC	3 1 PC	4 1 PC
			
5 1 PC	6 1 PC	7 1 PC	8 1 PC
			
9 4 PCS	10 1 PC	11 2 PCS	12 3 PCS
			
13 6 PCS	14 3 PCS	15 1 PC	16 2 PCS
			
17 4 PCS			

CODY BUFFET 3 DRAWER 3 SHELF 1 DOOR

STEP 1

Insert hardware **A1** onto panel (7).
(Repeat 2 times.)

Insert hardware **A2** onto panel (1).
(Repeat 8 times.)

Insert hardware **B** onto panel (7).
(Repeat 2 times.)

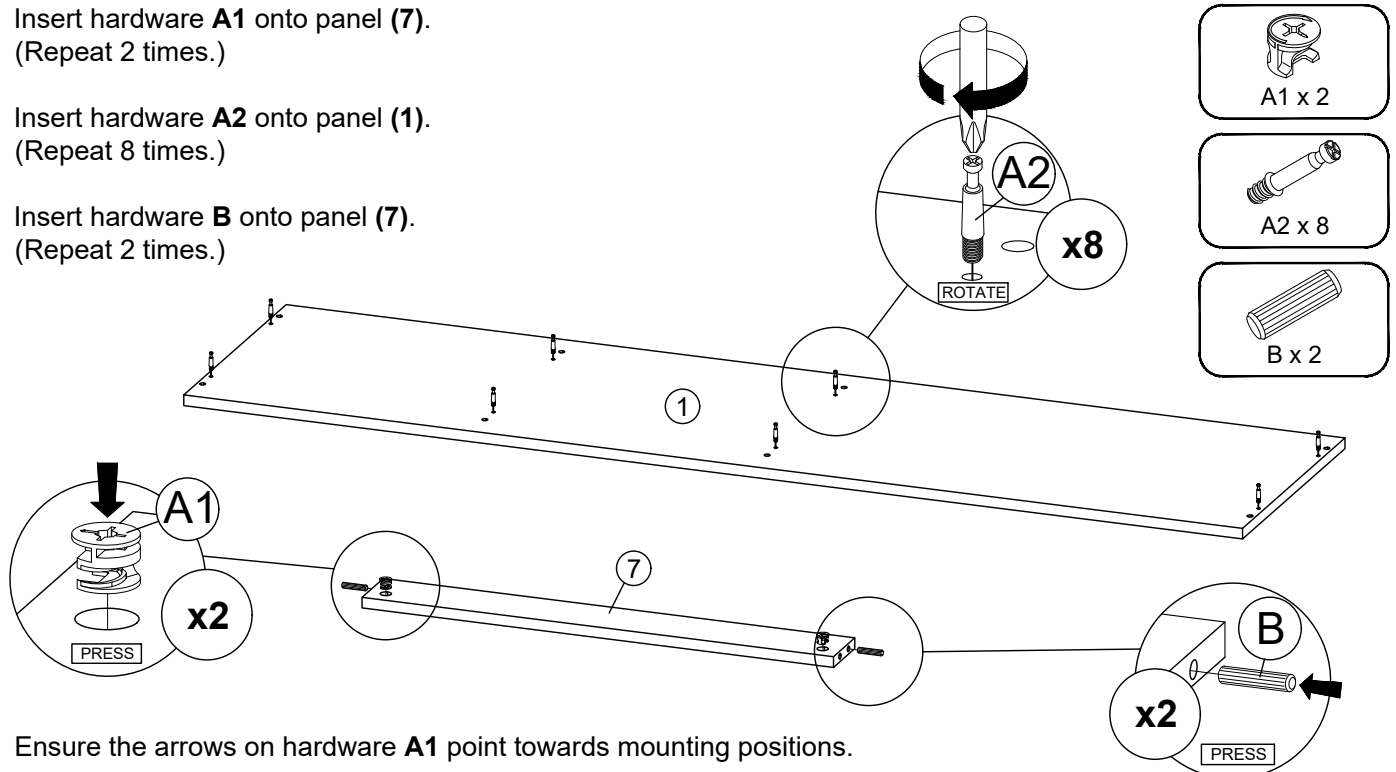

Ensure the arrows on hardware **A1** point towards mounting positions.

STEP 2

Insert hardware **A1** onto panel (3) and (5).
(Repeat 4 times.)

Insert hardware **A2** onto panel (3) and (5).
(Repeat 2 times.)

Insert hardware **B** onto panel (3) and (5).
(Repeat 8 times.)

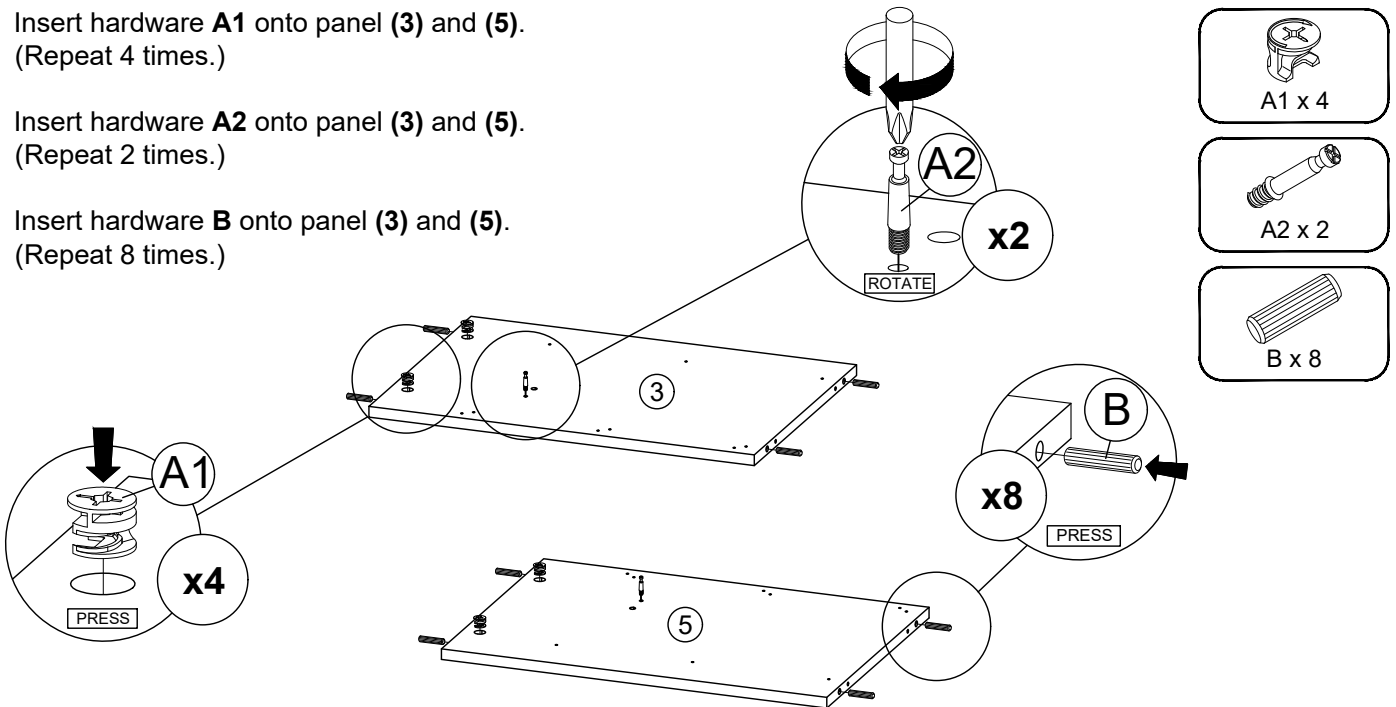

Ensure the arrows on hardware **A1** point towards mounting positions.

CODY BUFFET 3 DRAWER 3 SHELF 1 DOOR

STEP 3

Insert hardware **A1** onto panel (4) and (6).
(Repeat 4 times.)

Insert hardware **B** onto panel (4) and (6).
(Repeat 8 times.)

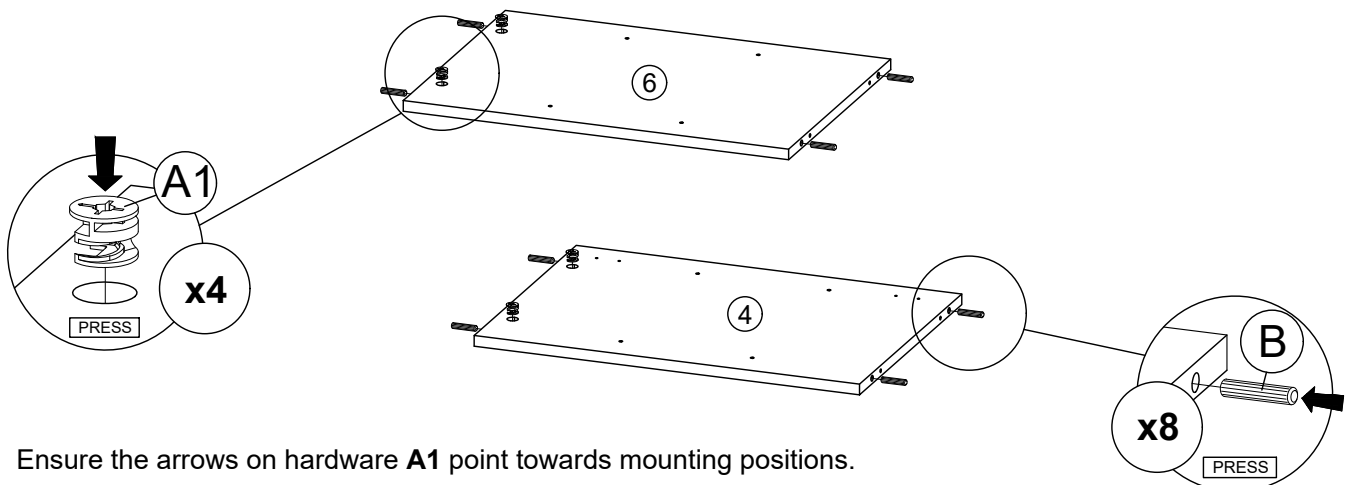
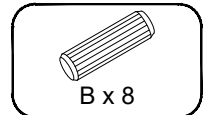

Ensure the arrows on hardware **A1** point towards mounting positions.

STEP 4

Fix hardware **N1 (L/R)** into panel (3) and (5) with hardware **F**.
(Repeat 4 times for each hardware.)

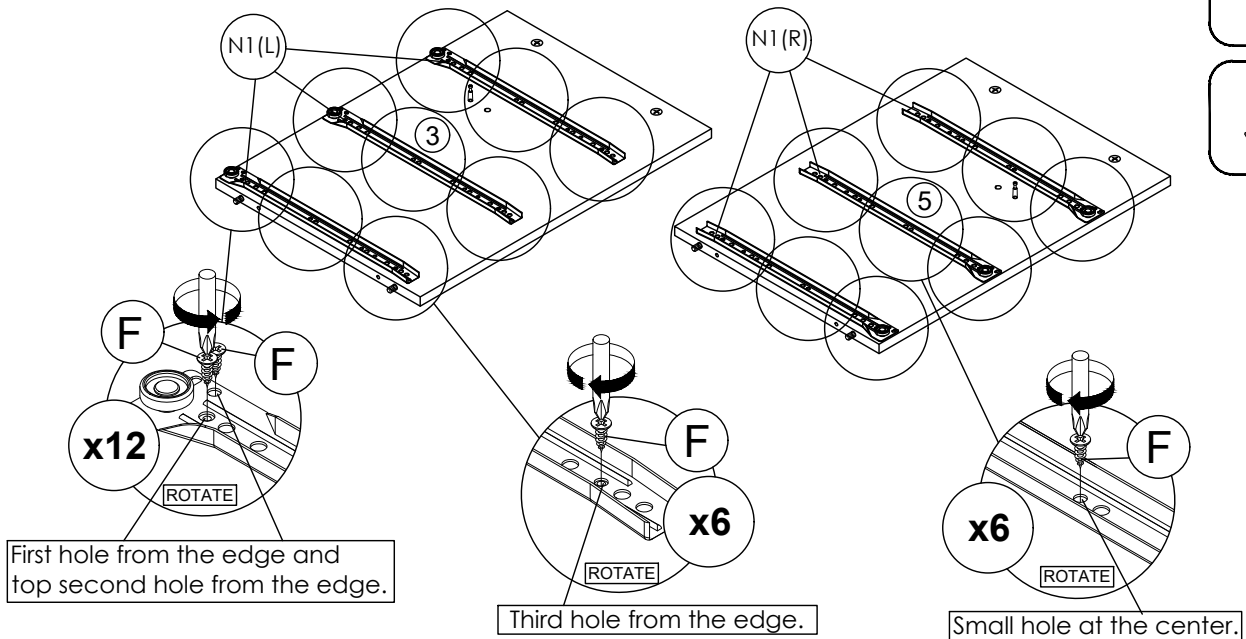
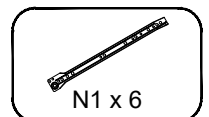
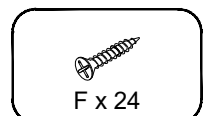

CODY BUFFET 3 DRAWER 3 SHELF 1 DOOR

STEP 5

Attach panel (3) and (5) to panel (7).

Insert all hardware **A2** into **A1**.

Rotate all **A1** until tight.

Apply **A3** onto all **A1**.
(Repeat 2 times.)

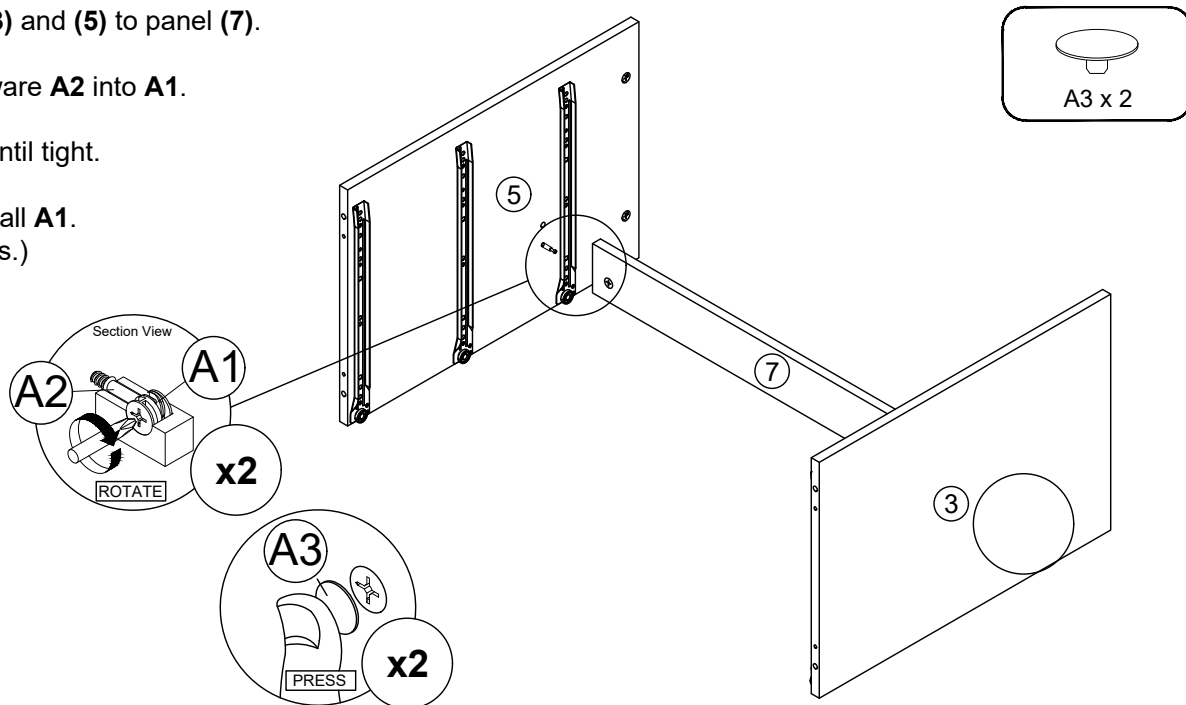

In this step hardware **A1**, **A2** and **B** are pre-inserted.

STEP 6

Attach panel (1) to panel (3), (4), (5) and (6).

Insert all hardware **A2** into **A1**.

Rotate all **A1** until tight.

Apply **A3** onto all **A1**.
(Repeat 8 times.)

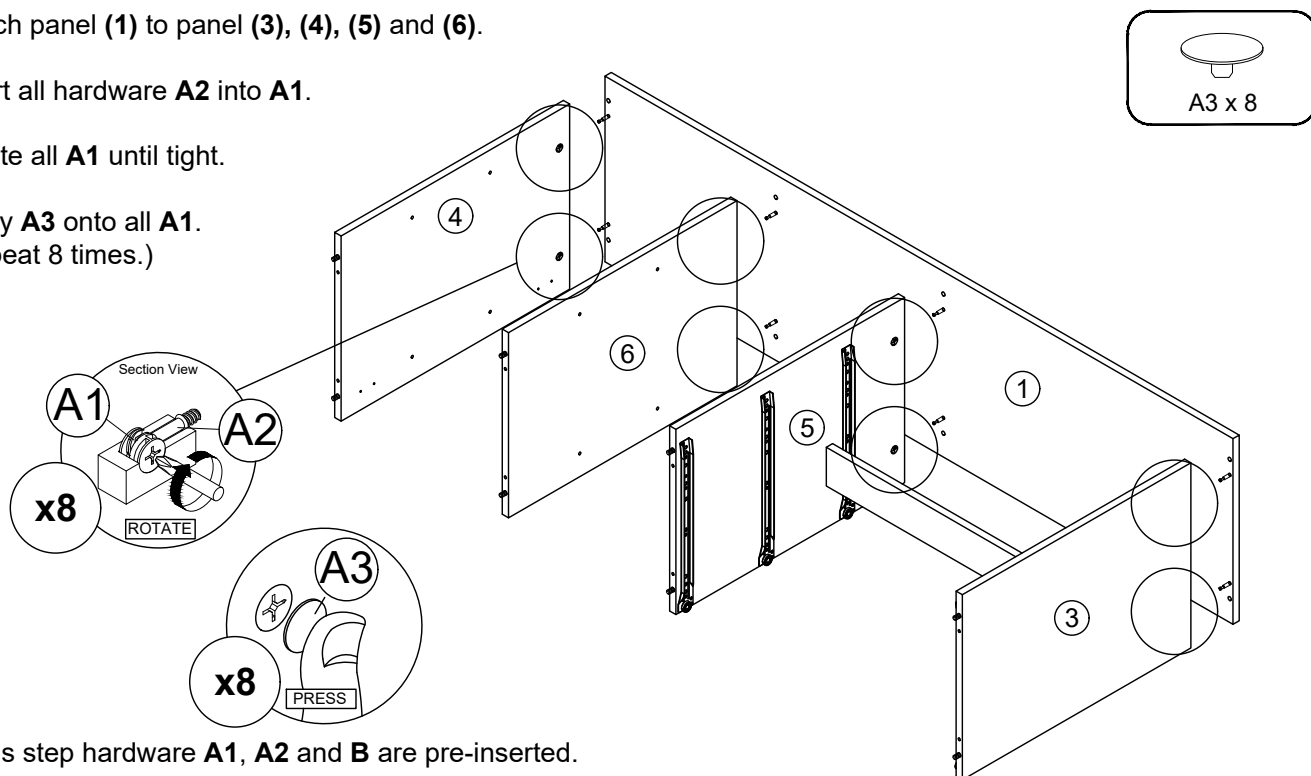

In this step hardware **A1**, **A2** and **B** are pre-inserted.

CODY BUFFET 3 DRAWER 3 SHELF 1 DOOR

STEP 7

Connect panel (2) to panel (3), (4), (5) and (6) by using hardware C and D.
(Repeat 8 times.)

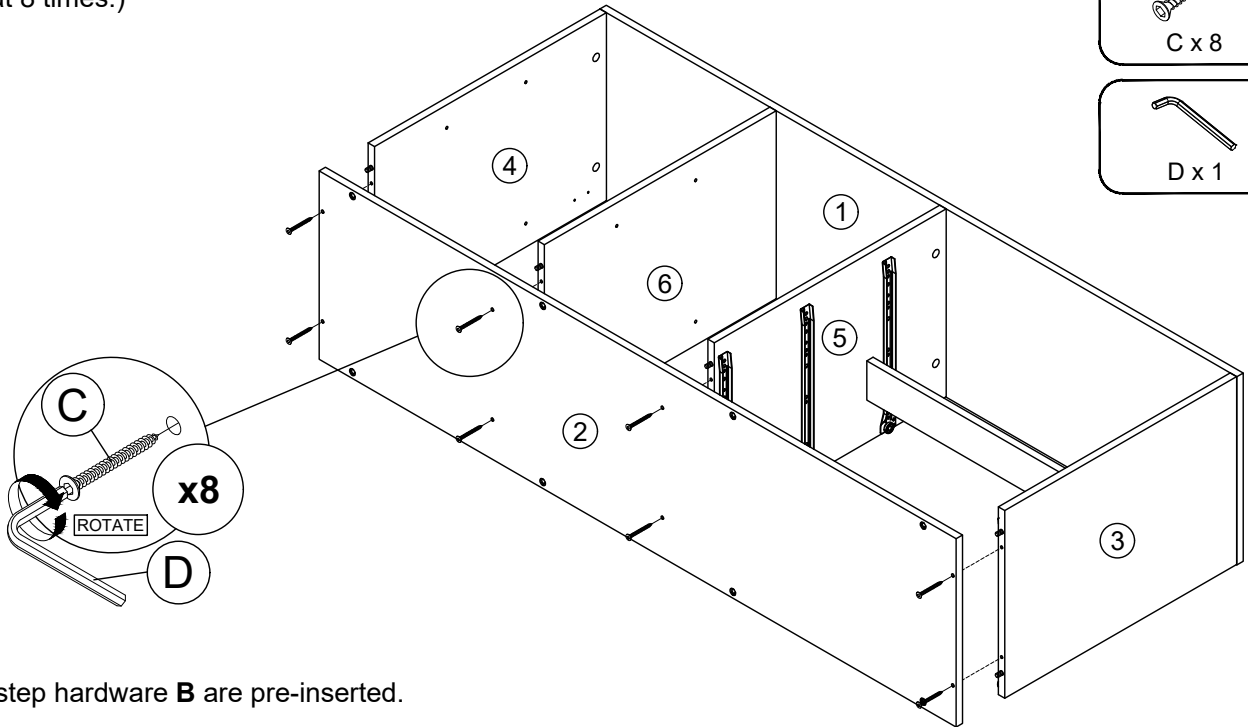
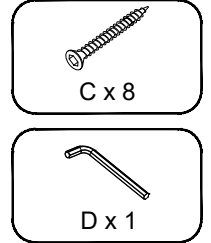

In this step hardware B are pre-inserted.

STEP 8

Assemble panel (8) to entire body with hardware H.
(Repeat 34 times.)

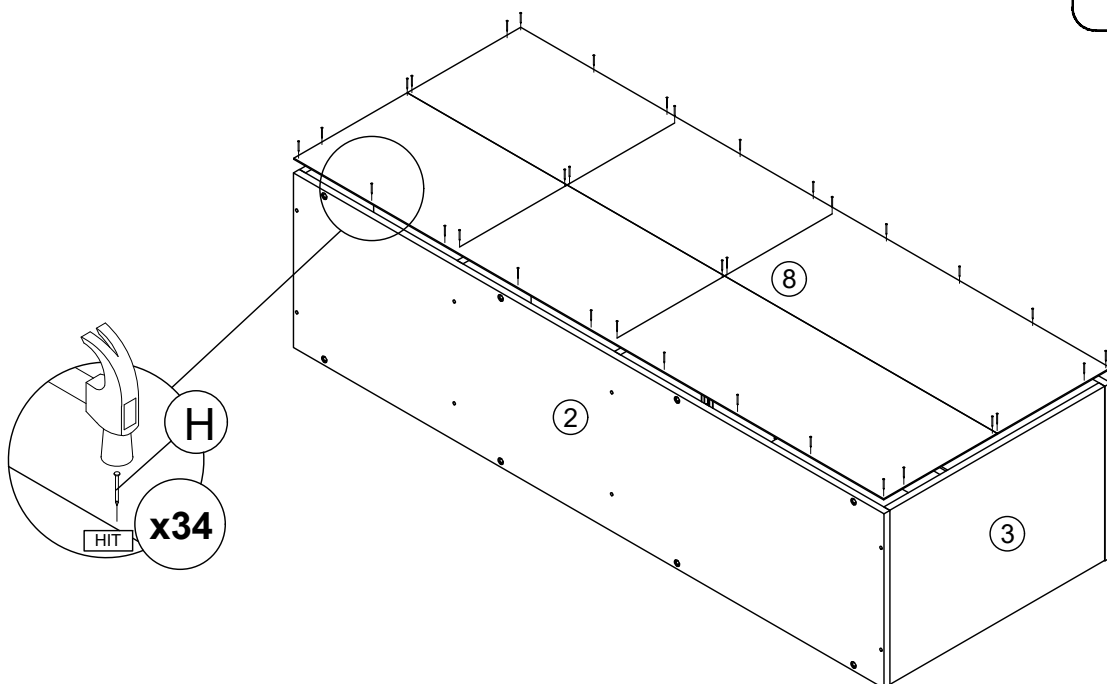
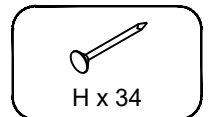

CODY BUFFET 3 DRAWER 3 SHELF 1 DOOR

STEP 9

Connect Metal Frame (16) to Metal Support (17) by using hardware D and K.
(Repeat 8 times.)

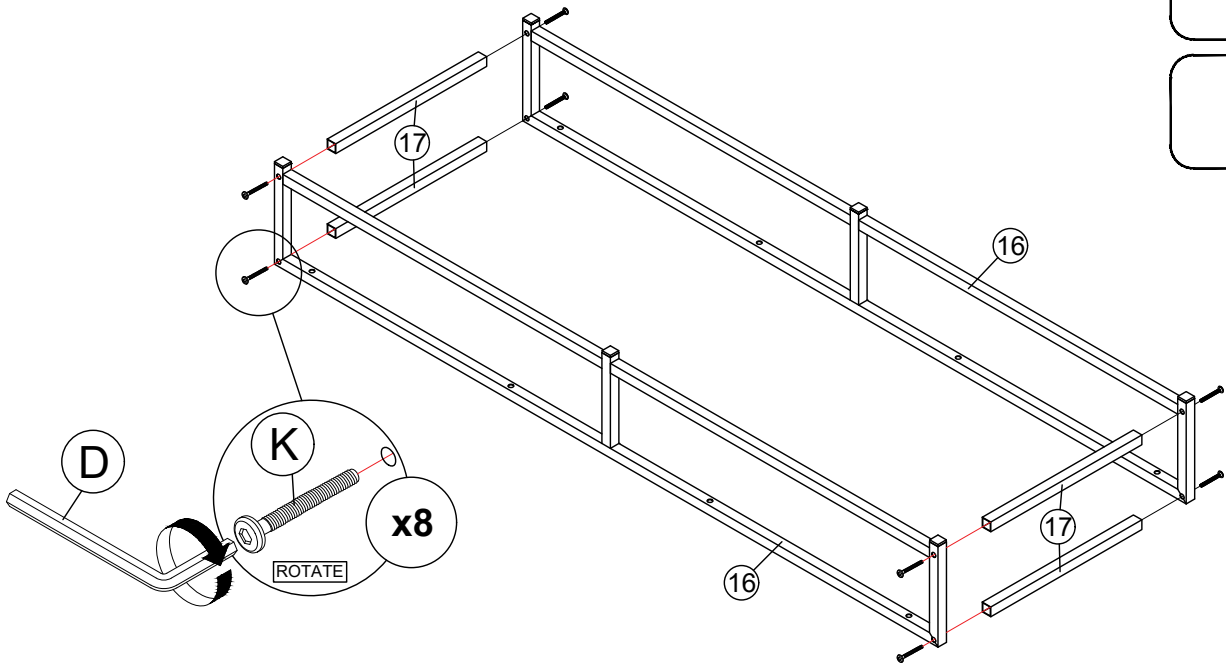
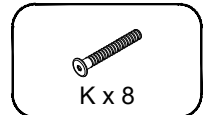
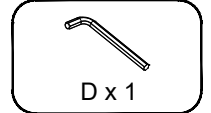

STEP 10

Connect Metal Frame (16) to panel (2) by using hardware D and J.
(Repeat 8 times.)

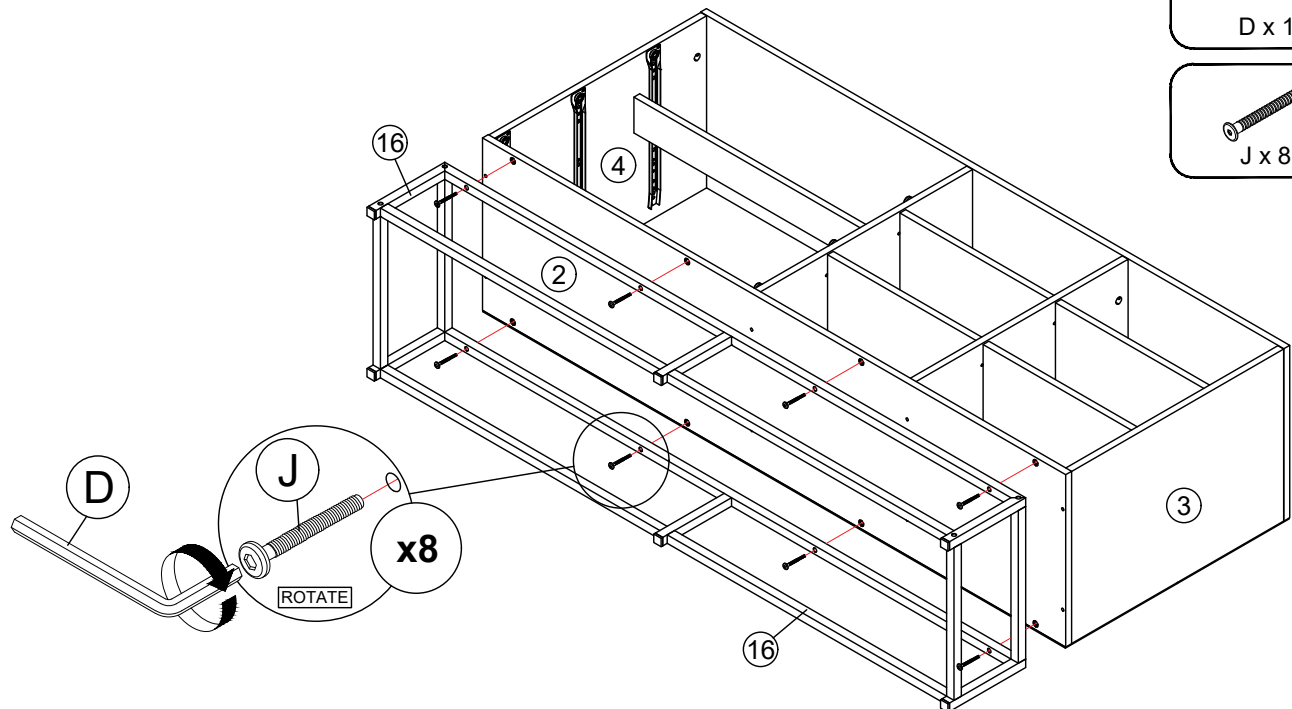
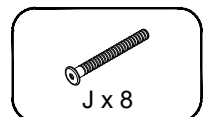
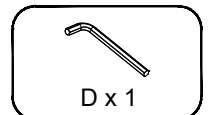

CODY BUFFET 3 DRAWER 3 SHELF 1 DOOR

STEP 11

Assemble panel (13) with panel (10) or (11) and (12) by using hardware G.
(Repeat 24 times.)

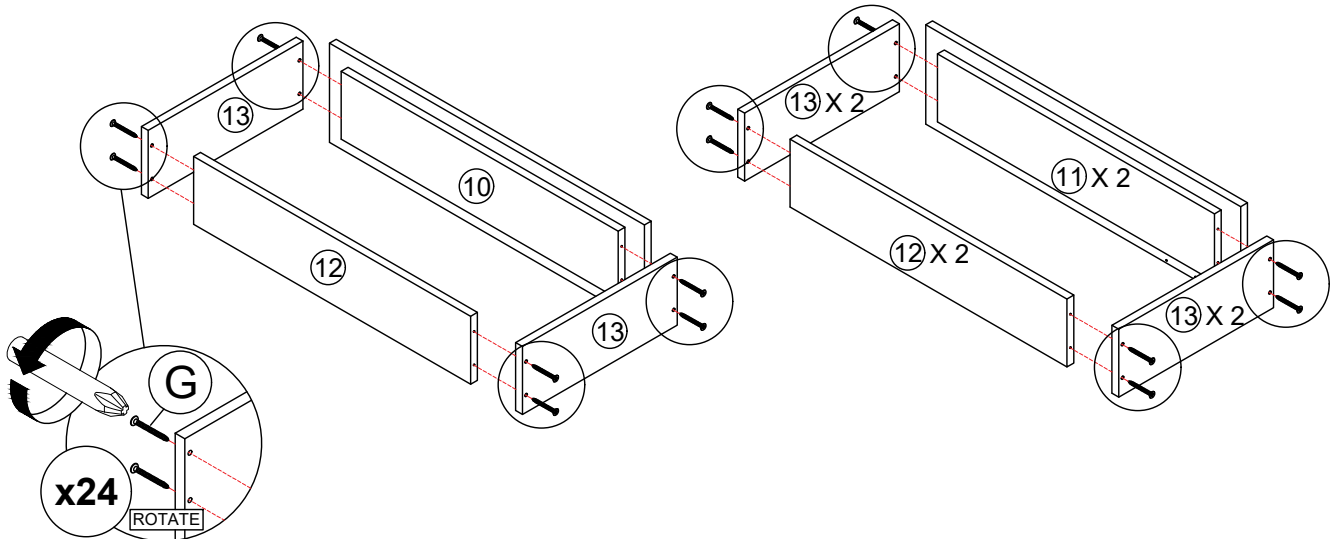

In this step only show one of the drawers.

STEP 12

Assemble panel (14) to entire body with hardware H.
(Repeat 24 times.)

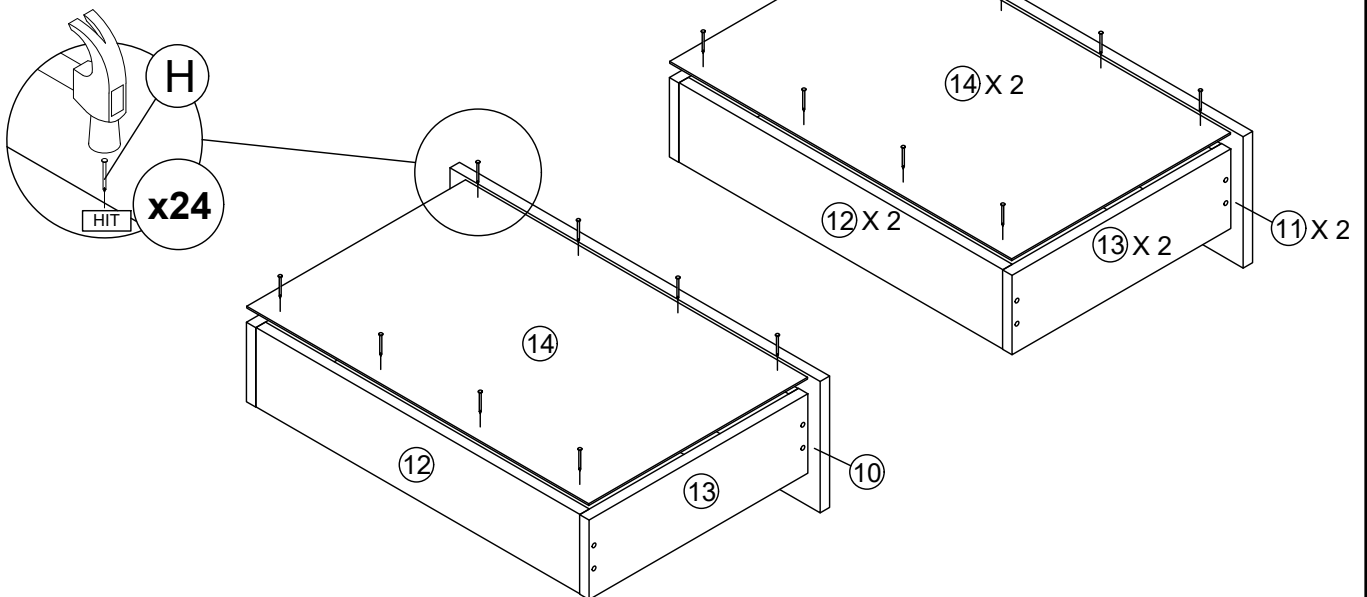

In this step only show one of the drawers.

CODY BUFFET 3 DRAWER 3 SHELF 1 DOOR

STEP 13

Assemble hardware **N2 (L/R)** to panel **(14)** by using hardware **F**.
(Repeat 3 times for each hardware.)

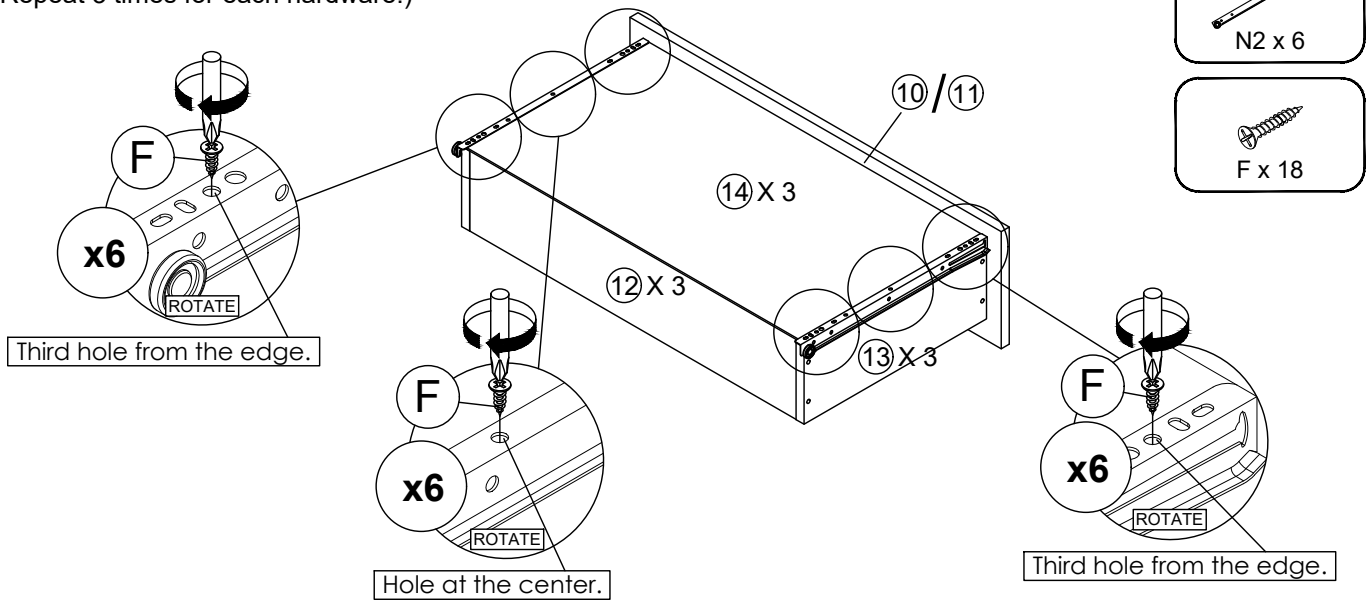

In this step only show one of the drawers.

Hardware **N2 (L/R)** shall be leaning against panel **(10)** or **(11)** when assembling.

STEP 14

Fix hardware **L** onto panel **(11)** by using hardware **E**.
(Repeat 2 times for each hardware.)

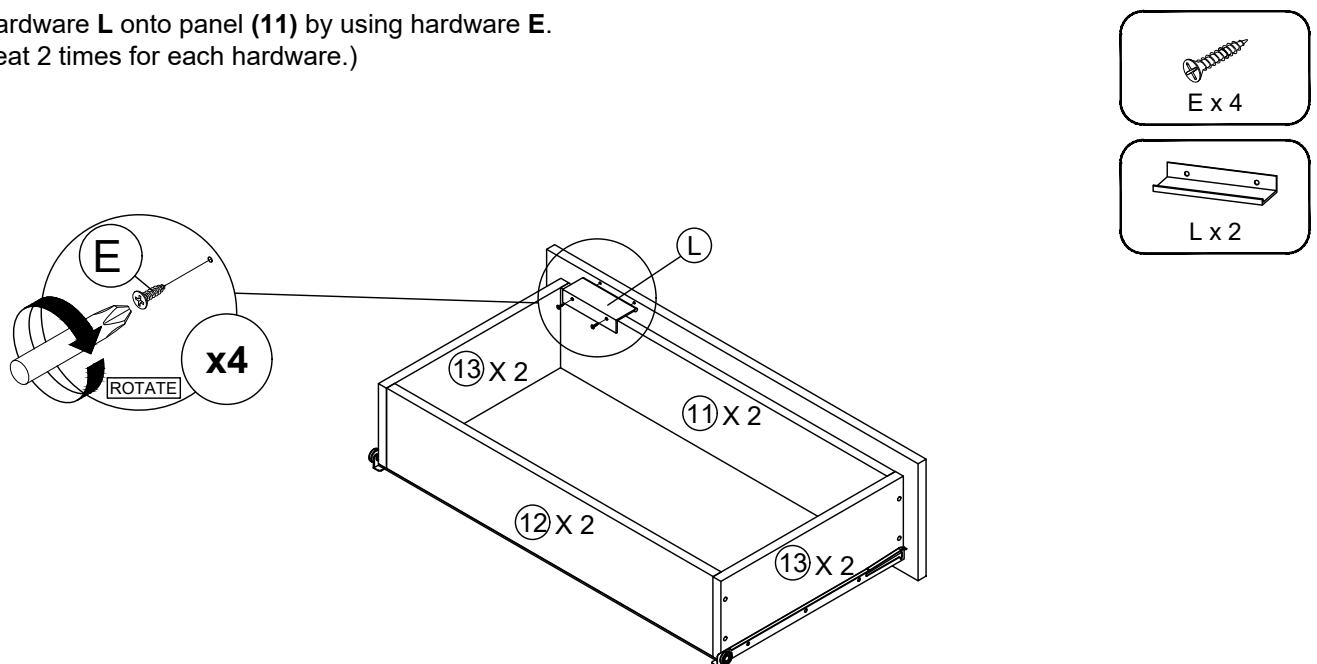

In this step only show one of the drawers.

CODY BUFFET 3 DRAWER 3 SHELF 1 DOOR

STEP 15

Put all the drawer in place along the drawer slides.

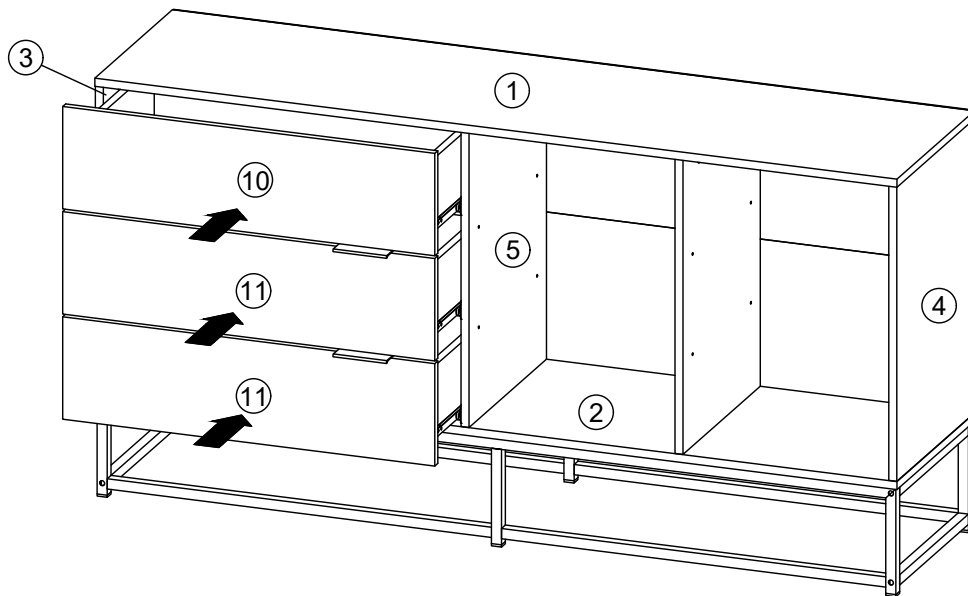

STEP 16

Insert hardware I into mounting positions on panel (4), (5) and (6) by hand.
(Repeat 16 times.)

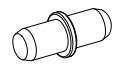

I x 16

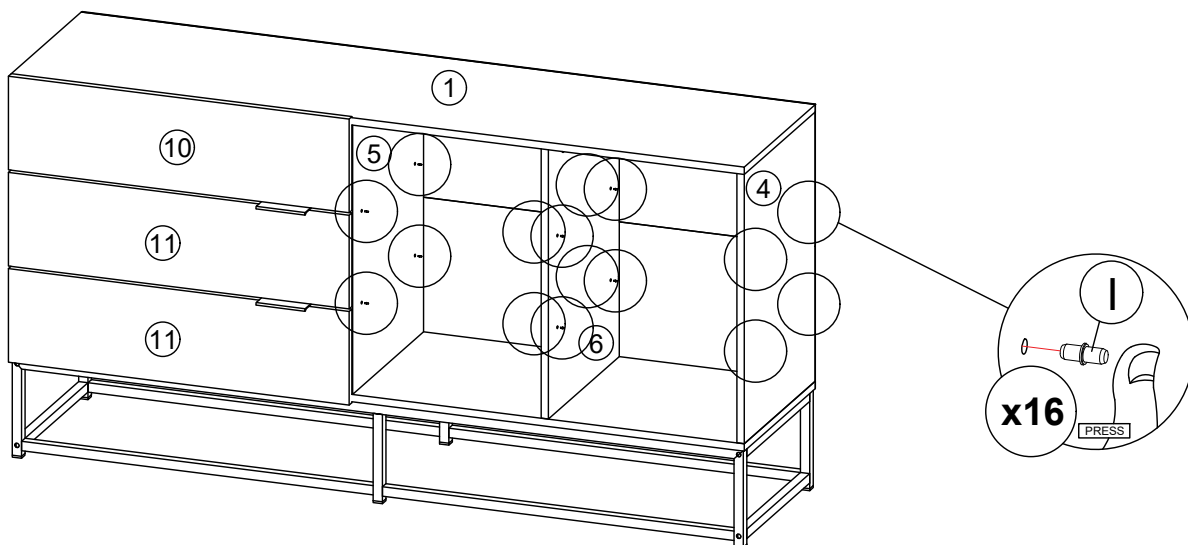

CODY BUFFET 3 DRAWER 3 SHELF 1 DOOR

STEP 17

Assemble the panel (9) into between panel (4) and (6).
(Repeat 2 times.)
Assemble the panel (9) into between panel (5) and (6).
(Repeat 2 times.)

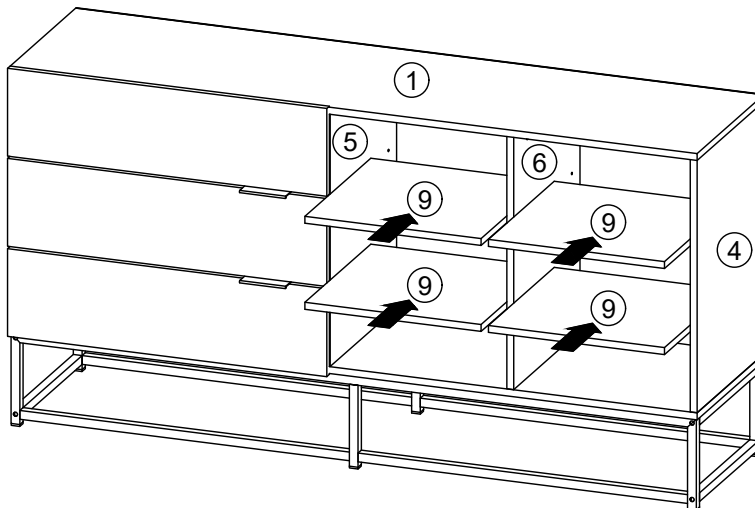

In this step hardware I are pre-inserted.

STEP 18

Fix hardware M onto panel (15) by using hardware F.
(Repeat 2 times for each hardware.)

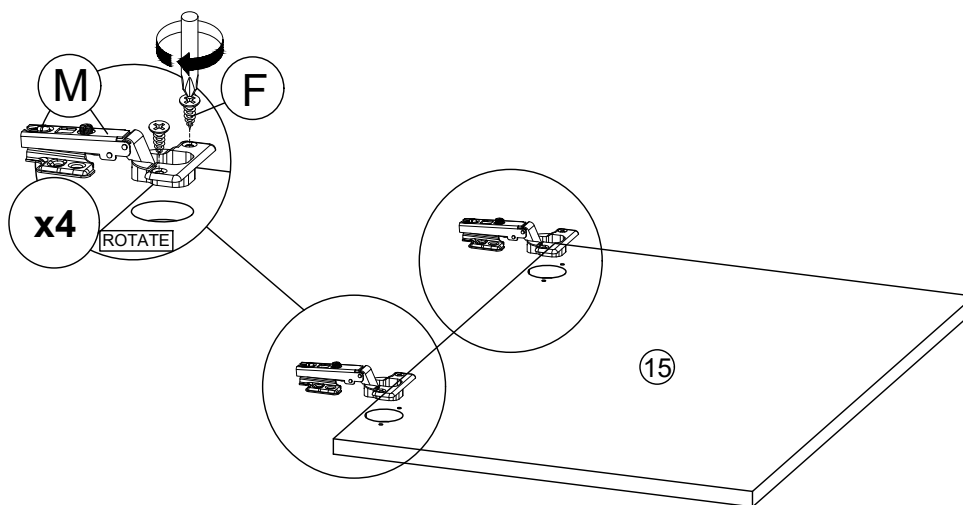

F x 4



M x 2

CODY BUFFET 3 DRAWER 3 SHELF 1 DOOR

STEP 19

Fix hardware **M** into panel **(4)** by using hardware **F**.
(Repeat 4 times for each hardware.)

Tighten or loosen the screw to adjust position of panel **(15)**.
(Do only when needed.)



F x 8

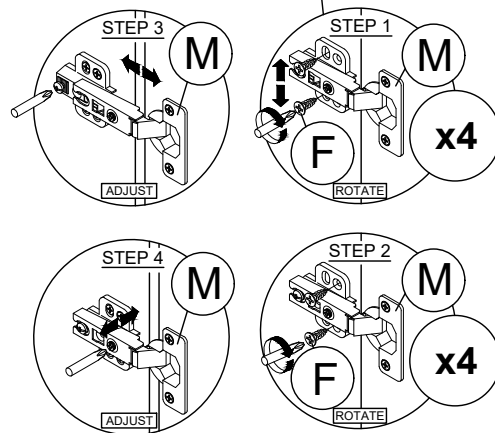
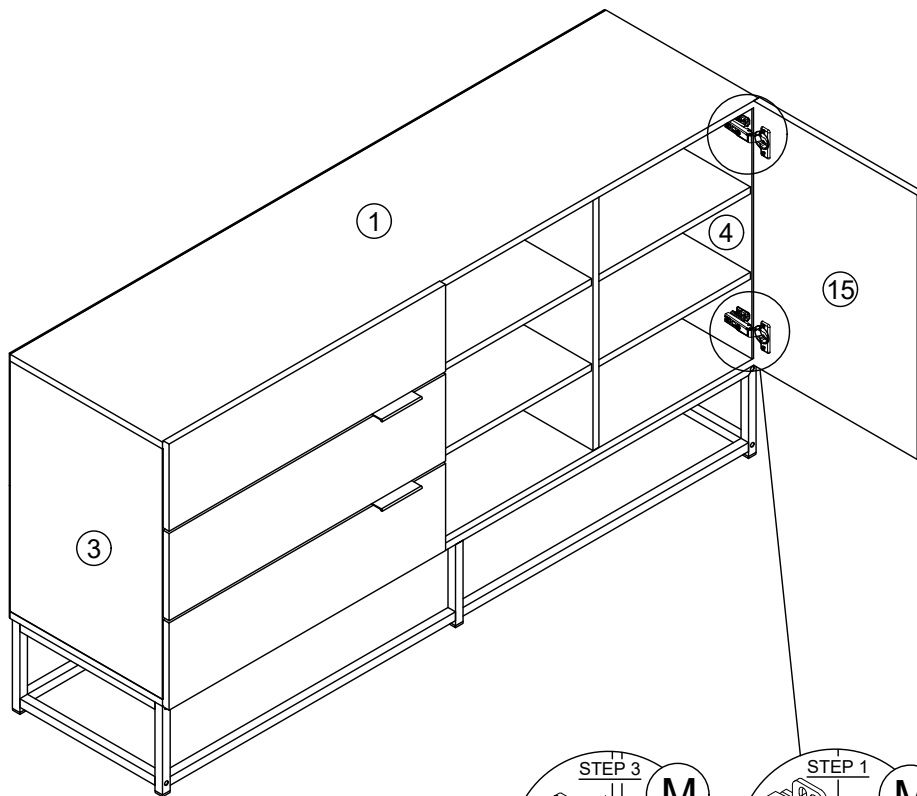

CODY BUFFET 3 DRAWER 3 SHELF 1 DOOR

STEP 20

Assemble hardware **O1** into panel **(8)** by using hardware **O2**.
(Repeat 2 times.)

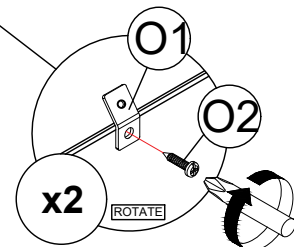
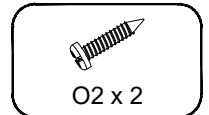
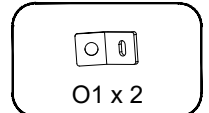
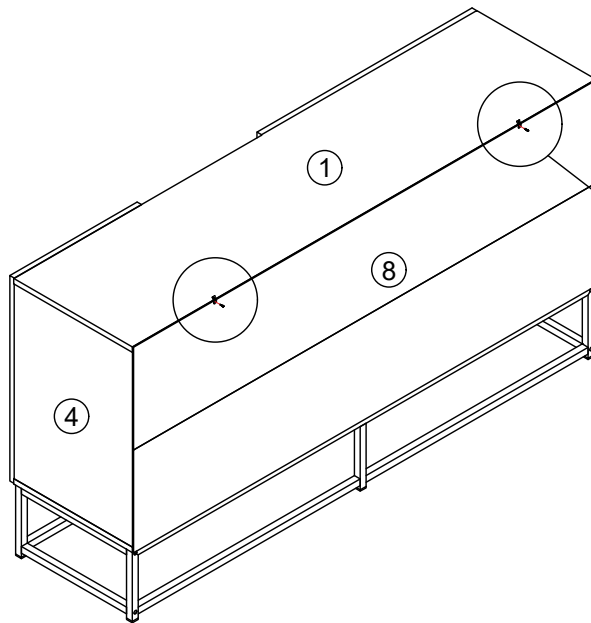

STEP 21

Assemble hardware **O1** at the wall by using hardware **O3**.
(Repeat 2 times.)

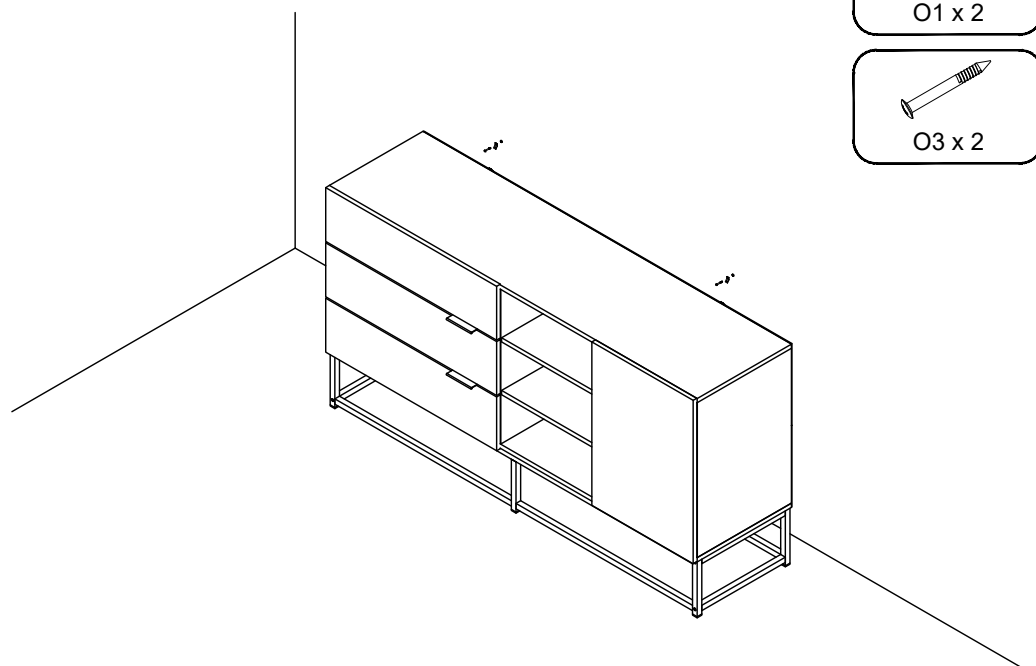
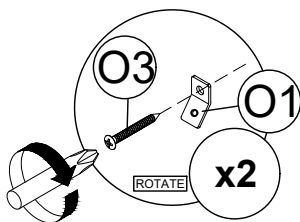
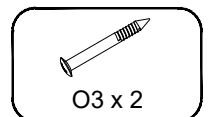
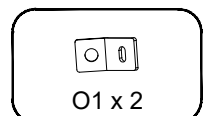

CODY BUFFET 3 DRAWER 3 SHELF 1 DOOR

STEP 22

Connect both of the hardware **O1** by using hardware **O4**.

Tighten the hardware **O4**.
(Repeat 2 times.)

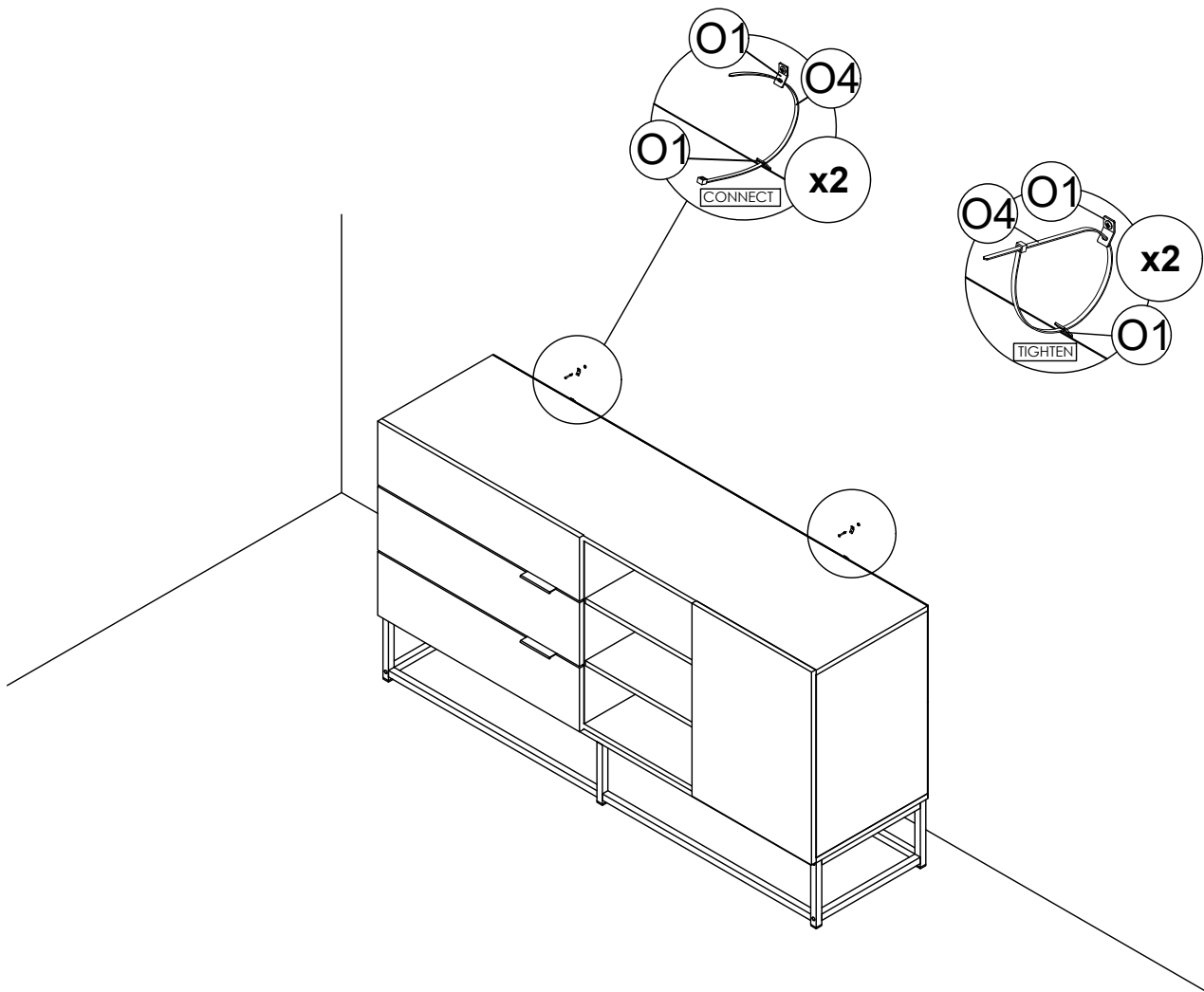
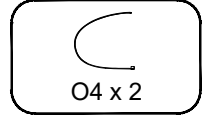

Your Cabinet is ready for use.

CODY BUFFET 3 DRAWER 3 SHELF 1 DOOR

WALL FIXING GUIDE

NOTE: Supplied wall plugs are only suitable for use in masonry walls.

If you have any doubts about using the correct plug for your wall, please seek professional advice. Failure of the product due to using incorrect fixings is the responsibility of the installer.



IMPORTANT:

When drilling into walls, always check for hidden wires or pipes, etc.



Tips & Tricks

Make sure that the hardware used is suitable for supporting your unit.

Please consult a qualified tradesperson if unsure.

- ✓ If you are unsure, please select a larger screw and wall plug.
- ✓ Ensure that you use the recommended drill bit to match the wall plug and hole size.
- ✓ Take extra care when drilling high walls, ceiling and ceramic tiles. Ensure wall plugs are inserted beyond the thickness of the ceramic tiles to avoid splitting or cracking.
- ✓ Ensure that wall plugs are well fitted and are a tight fit in the drilled hole.

Types of Walls

Use one of the following types of wall plug (not included) if your walls are made of brick, breeze block, concrete, stone or wood. Screws may be able to be fixed directly to solid wood walls as they will provide a secure anchor point.

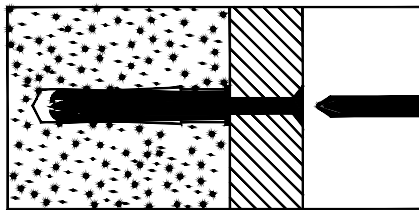

1. General Purpose Wall Plug

Generally, aerated blocks should not be used to support heavy loads, use a specialist fitting in this case. For light loads, general purpose wall plugs can be used.

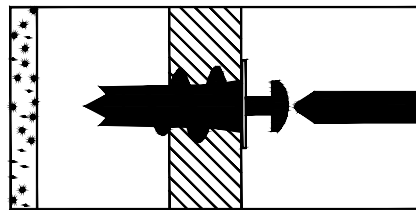

2. Plasterboard Wall Plug

For use when attaching light loads onto plasterboard partitions.

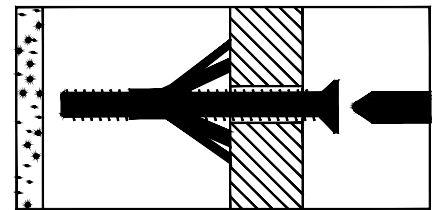

3. Cavity Fixing Wall Plug

For use with plasterboard partitions or hollow wooden doors.

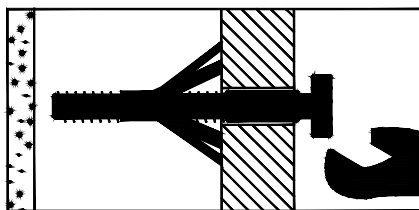

4. Cavity Fixing Heavy Duty Wall Plug

For use when fitting or supporting heavy loads such as shelving and wall cabinets.

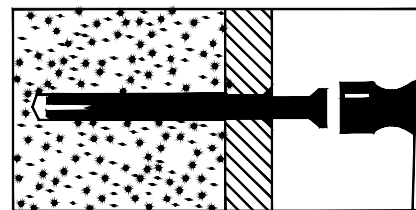

5. Hammer Fixing Wall Plug

For use with concrete block or brick walls, or walls stuck with plasterboard. The hammer fixing allows it to be fixed to the wall rather than the plasterboard. Always check the fixing is secure to the retaining wall.

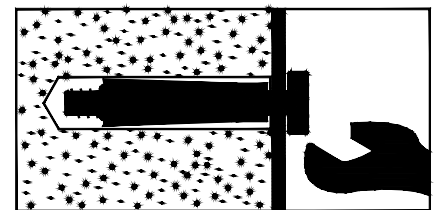

6. Shield Anchor Wall Plug Heavy Loads

For use with concrete or brick walls, or for use with heavier loads such as TV & HiFi speakers and satellite dishes, etc.