

# ASSEMBLY INSTRUCTIONS















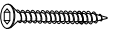



PAGE: 1/5

MODEL : UH 8684

Before you begin, please follow assembly instructions carefully, then follow them step by step.

Read instruction carefully . See Furniture Parts list and Hardware List for guidance . Be sure you have all parts before you start assembling . Place and assemble furniture on a clean flat soft surface , such as carpet or rug to prevent being scratched .

PART LIST		QTY
1	TOP PANEL	1 PC
2	BOTTOM PANEL	1 PC
3	SIDE PANEL (L)	1 PC
4	SIDE PANEL (R)	1 PC
5	BACK PANEL	1 PC
6	DRAWER FRONT (UP)	1 PC
7	DRAWER FRONT (DOWN)	1 PC
8	DRAWER SIDE	4 PCS
9	DRAWER BACK	2 PCS
10	DRAWER BOTTOM	2 PCS
11	METAL SIDE	2 PCS
12	METAL SUPPORT	4 PCS

HARDWARE				
A	MINI FIX	A1  A2  A3 		4 SETS
B	M8 X 30MM WOOD DOWEL			8 PCS
C	M6 X 50MM CSK CAP WOOD SCREW			4 PCS
D	ALLEN KEY M4			1 PC
E	JCBC SCREW M6 X 30MM			4 PCS
F	JCBC SCREW M6 X 40MM			8 PCS
G	M3 X 12MM C.B SCREW			2 PCS
H	M3.5 X 16MM C.B SCREW			24 PCS
I	M4 X 38MM C.B SCREW			16 PCS
J	5/8 NAIL			30 PCS
K	HANDLE 4020 L BAR 100MM			1 PC
L	14" DRAWER SLIDE		L1 (L/R) L2 (L/R)	2 SETS
M	TIPPING PACK WITH AI	M1  M2  M3  M4 		2 SETS
N	WALL PLUG ( NOT INCLUDED )			-

SELF-PREPARED TOOLS: Tools below are NOT included in package.



SCREWDRIVER



HAMMER

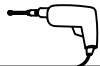

POWER DRILL

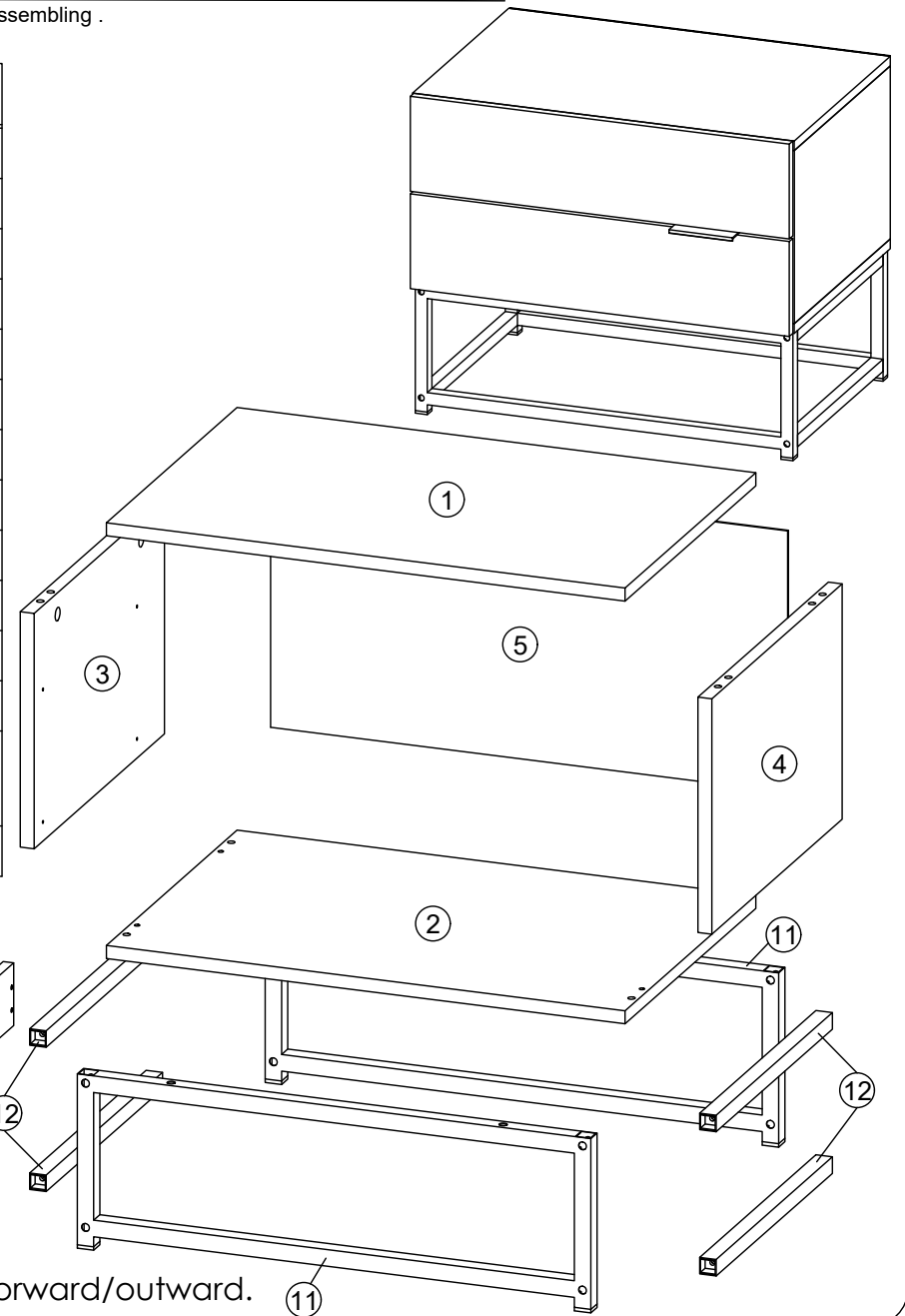

## Reminder:

Please ensure that all surfaces and edges with colours/laminations are facing forward/outward.

# ASSEMBLY INSTRUCTIONS

PAGE: 2/5

# MODEL : UH 8684

## STEP 1

- Insert hardware **A1** onto panel **(3)** and **(4)**.  
(Repeat 4 times.)
- Insert hardware **A2** onto panel **(1)**.  
(Repeat 4 times.)
- Insert hardware **B** onto panel **(3)** and **(4)**.  
(Repeat 8 times.)

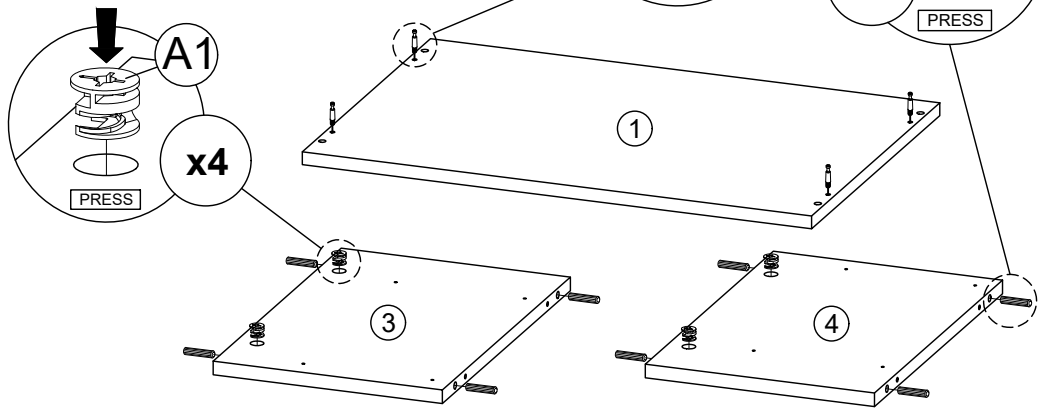

\* Ensure the arrows on hardware **A1** point towards mounting positions.

## STEP 2

- Fix hardware **L1 (L/R)** into panel **(3)** and **(4)** with hardware **H**.  
(Repeat 3 times for each hardware.)

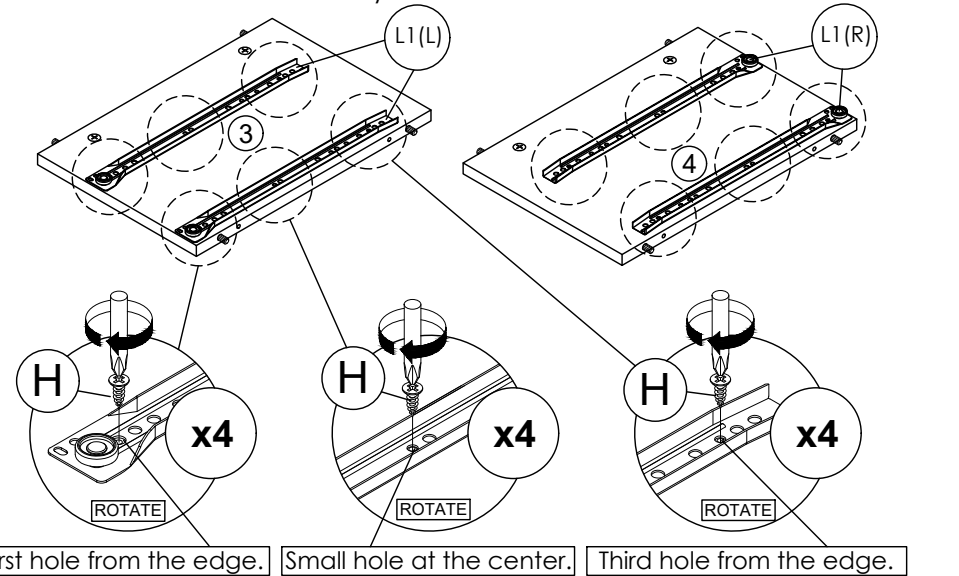

First hole from the edge. Small hole at the center. Third hole from the edge.

## STEP 3

- Attach panel **(3)** and **(4)** to panel **(1)**.
- Insert all hardware **A2** into **A1**.
- Rotate all **A1** until tight.
- Apply **A3** onto all **A1**.  
(Repeat 4 times.)

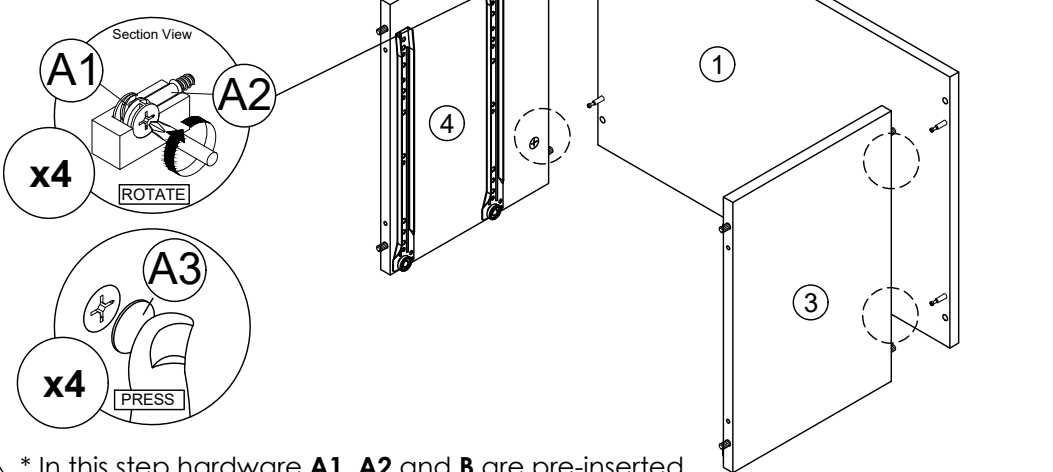

\* In this step hardware **A1**, **A2** and **B** are pre-inserted.

## STEP 4

- Connect panel **(2)** to panel **(3)** and **(4)** by using hardware **C** and **D**.  
(Repeat 4 times.)

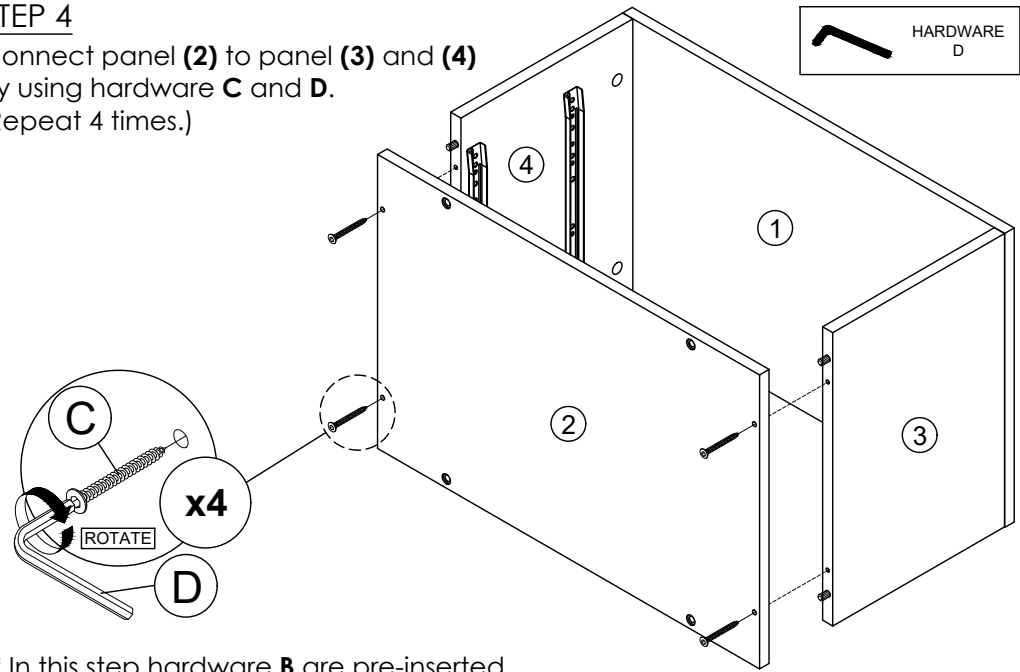

\* In this step hardware **B** are pre-inserted.

# ASSEMBLY INSTRUCTIONS

PAGE: 3/5

# MODEL : UH 8684

## STEP 5

Assemble panel (5) to entire body with hardware J.  
(Repeat 14 times.)

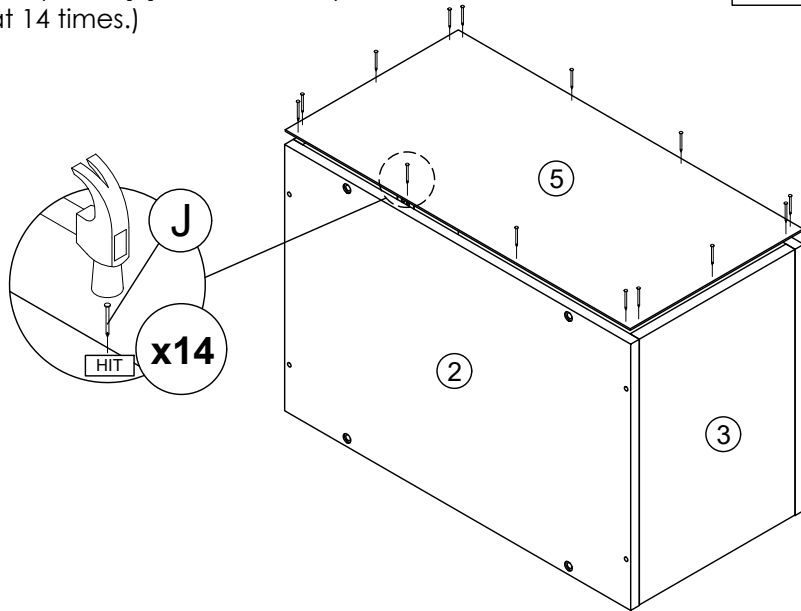

## STEP 6

Connect Metal Side (11) to Metal Support (12)  
by using hardware D and F.  
(Repeat 8 times.)

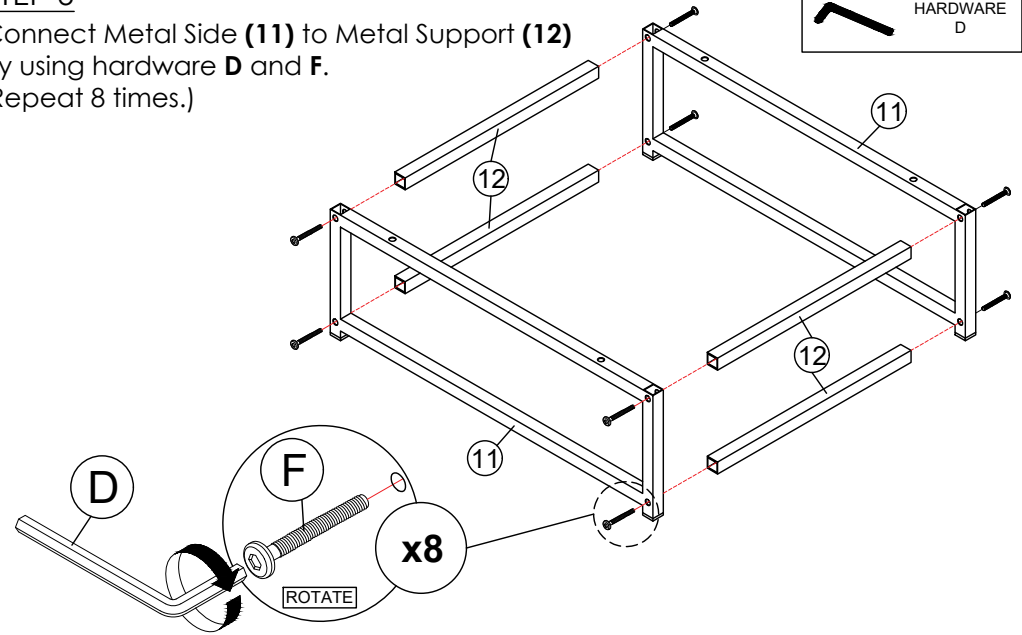

## STEP 7

Connect Metal Side (11) to panel (2) by  
using hardware D and E.  
(Repeat 4 times.)

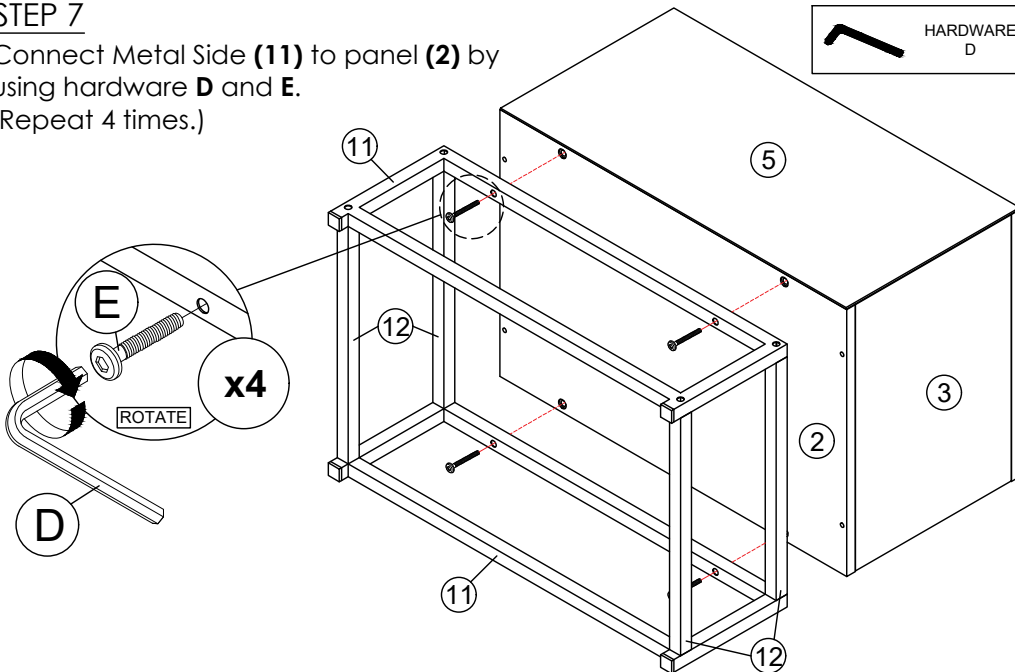

## STEP 8

Assemble panel (8) with panel (6) or (7) and (9)  
by using hardware I.  
(Repeat 16 times.)

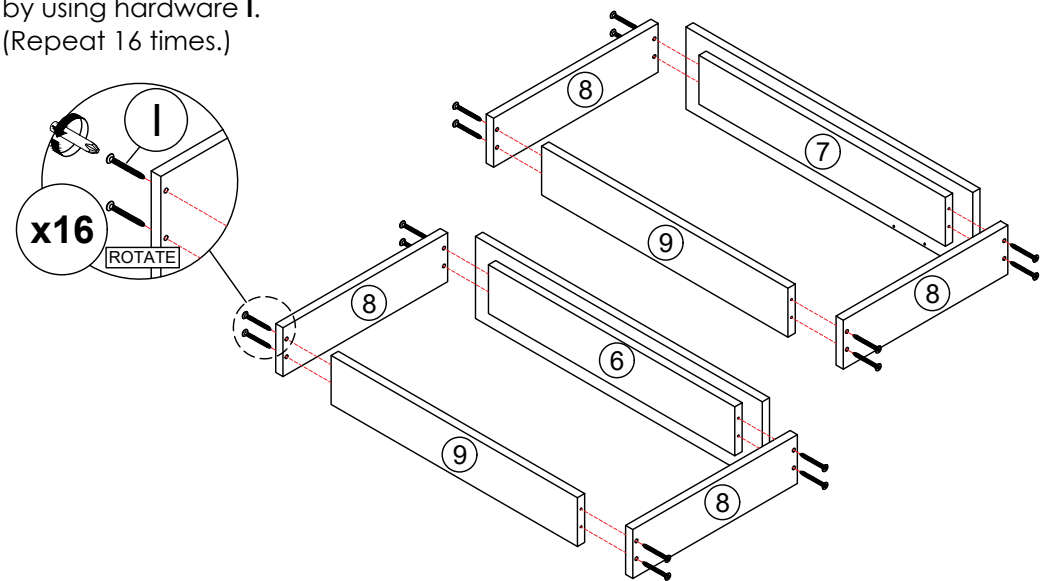

# ASSEMBLY INSTRUCTIONS

PAGE: 4/5

# MODEL : UH 8684

## STEP 9

Assemble panel **(10)** to entire body with hardware **J**.  
(Repeat 16 times.)

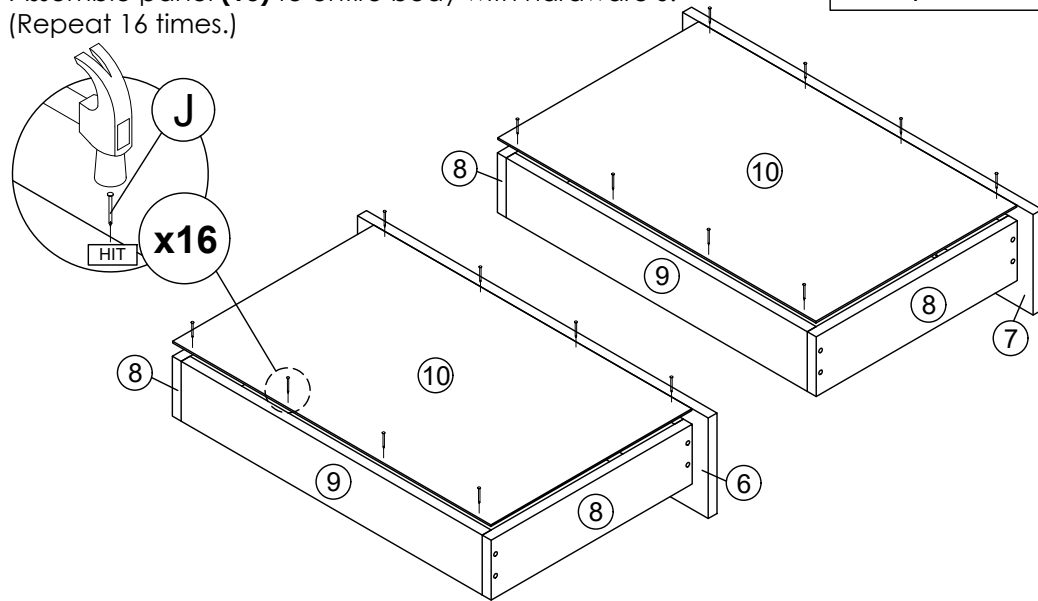

## STEP 10

Assemble hardware **L2 (L/R)** to panel **(10)** by using hardware **H**.  
(Repeat 3 times for each hardware.)

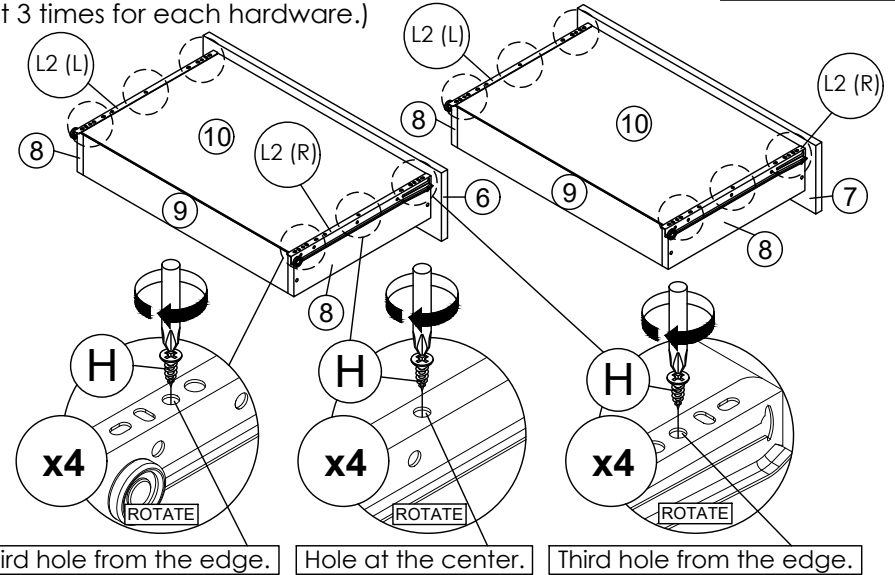

Third hole from the edge.    Hole at the center.    Third hole from the edge.

\*Hardware **L2 (L/R)** shall be leaning against panel **(6)** or **(7)** when assembling.

## STEP 11

Fix hardware **K** onto panel **(7)** by using hardware **G**.  
(Repeat 2 times.)

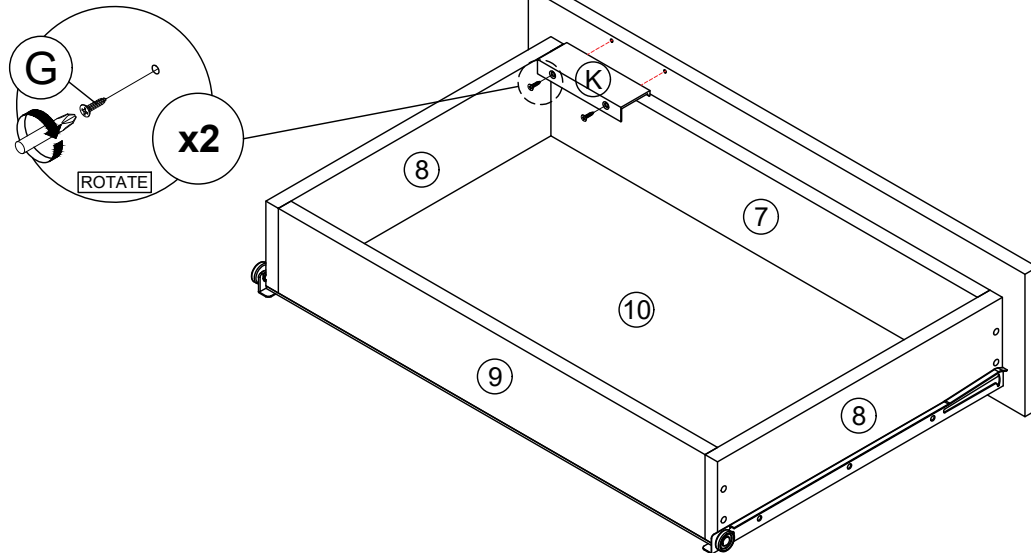

## STEP 12

Put all the drawer in place along the drawer slides.

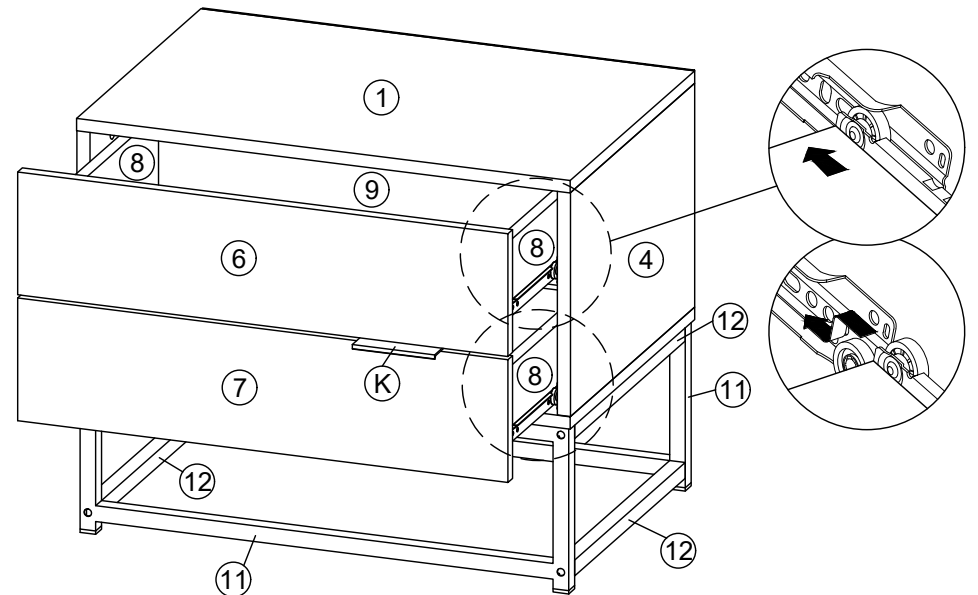

# ASSEMBLY INSTRUCTIONS

PAGE: 5/5

# MODEL : UH 8684

## STEP 13

Assemble hardware **M1** into panel **(1)** and **(5)** by using hardware **M2**.  
(Repeat 2 times.)

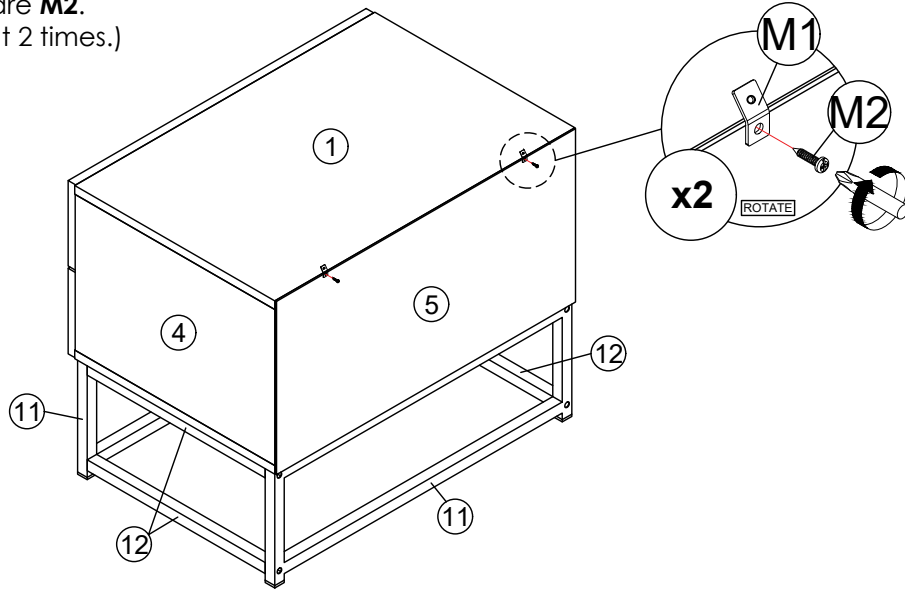

## STEP 14

- Mark and use the power drill to drill a hole on the wall.  
- Hit hardware **N** into the wall.  
(Repeat 2 times.)

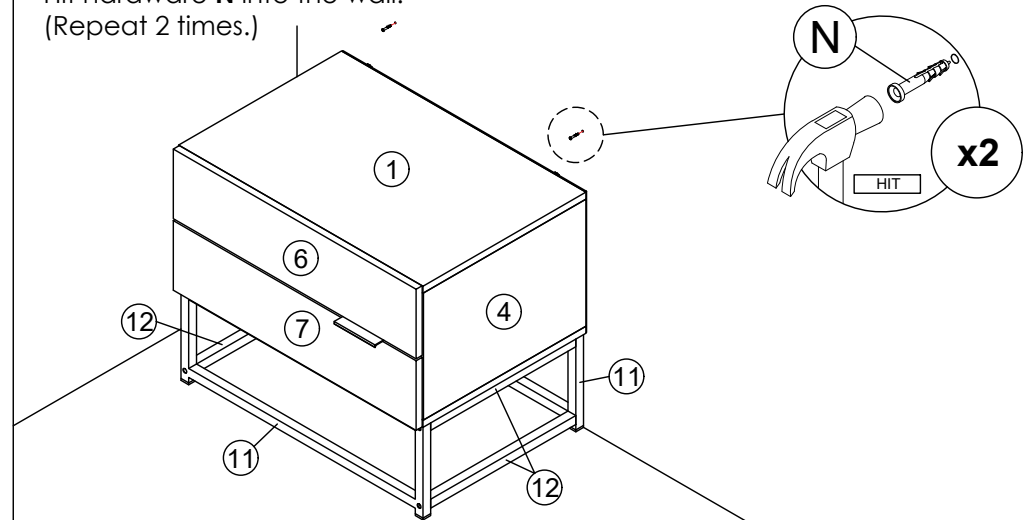

\* In this step hardware **N** are **NOT** included.

## STEP 15

- Assemble hardware **M1** into **N** by using hardware **M3**.  
(Repeat 2 times.)

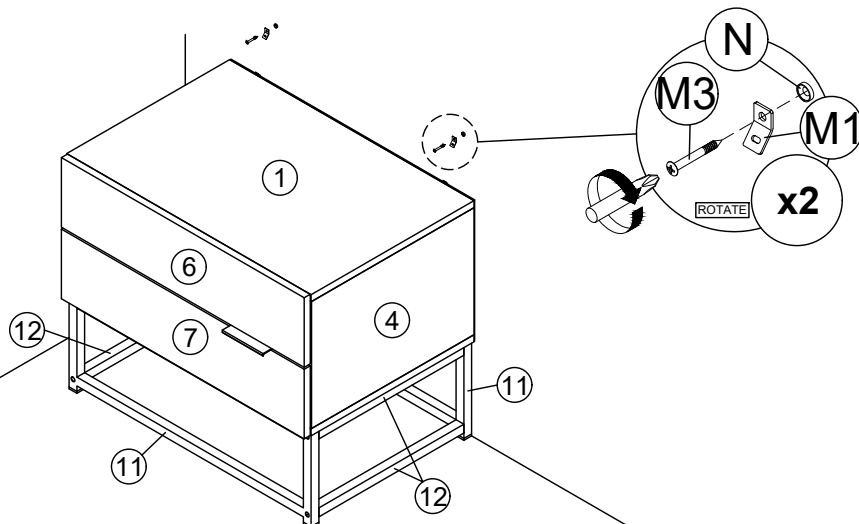

\* In this step hardware **N** are **NOT** included.

## STEP 16

- Connect both of the hardware **M1** by using hardware **M4**.  
- Tighten the hardware **M4**.  
(Repeat 2 times.)

