

# MONTREAL CUPBOARD SINGLE DOOR TALL

ITEM CODE:61492

**1.5 HR**

APPROXIMATE ASSEMBLY TIME



**2 PERSON  
ASSEMBLY**

FLOOR AREA  
2.0M X 2.0M



REQUIRED ASSEMBLY SPACE

REQUIRED ASSEMBLY TOOLS

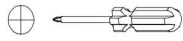

POZI SCREWDRIVER

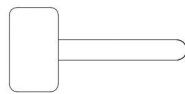

HAMMER

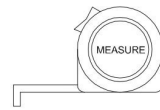

MEASURING TAPE



DRILL

**ASSEMBLED DIMENSIONS**

**61492**

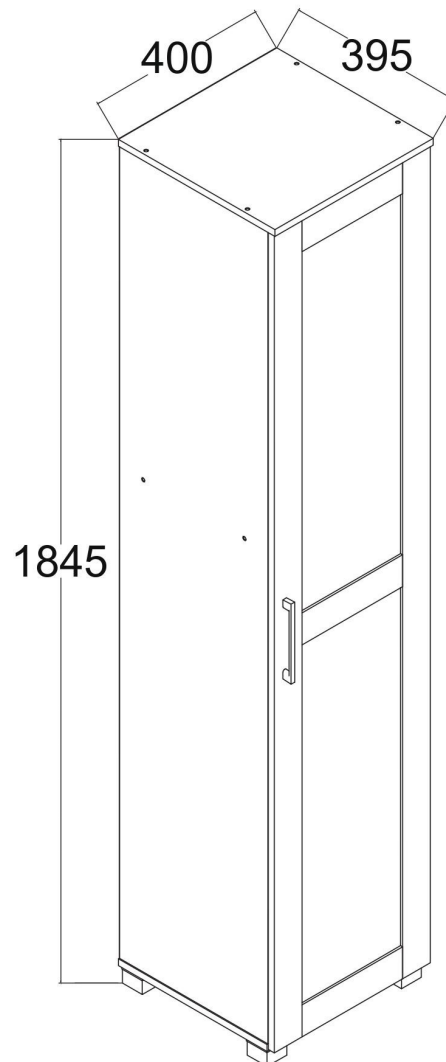

# MONTREAL CUPBOARD SINGLE DOOR TALL

## ITEM CODE:61492

### **Important :**

Please read these instructions carefully before use and keep for future reference.

- This product is intended for domestic use only and is not designed for commercial use.
- DO NOT assembly / use this item if any components are missing or damaged. Please contact the retailer straight away.
- DO NOT attempt to modify your item as this will void your warranty. Please call the retailer for required parts.
- Assembly to be carried out by a competent adult only.
- During assembly children should be kept away from the product due to possible risk of injury.

**Please refer to separate Warranty Certificate for full warranty details and information.**

### **Tips before you start :**

- Please check that all parts are present before you start the assembly of your furniture. Please do not start to build your item if any parts are damaged as this may void your warranty. Please contact the retailer immediately so they can advise what you should do.
- For ease and speed of assembly, we recommend that before you commence each step of the assembly, that you identify all the parts required for that step.

# MONTREAL CUPBOARD SINGLE DOOR TALL

## ITEM CODE:61492

### Assembly Tips:

1. For larger items, please ensure that you have sufficient space and people (as indicated on page 1) to assembly your product safely.
2. We recommend that, where possible, all items are assembled near to the area in which they will be placed in use, to avoid moving the product unnecessarily once assembled.
3. For the protection of your furniture, we recommend that the product is placed on a protected surface during assembly to prevent any damage.
4. During assembly please take care not to over-tighten any fittings, as this may damage the product.
5. Always place the product on a flat, steady and stable surface.
6. Do not stand on the product. Do not use the product as a stepladder.
7. This product is intended for indoor, household use only as it is non industrial product.
8. Use of power tools is NOT recommended for assembling this product as over-tightening may occur and damage the product.
9. Due to the laminated finish of this item and the materials used to construct it, when first opening the carton and assembling a slight smell may be noticeable. This will dissipate over a short period of time. Please contact the retailer you purchased this item from if you have any concerns.
10. Please use caution and care when lifting the product to avoid personal injury and / or damage.

### Care and Maintenance of your Furniture

- Please periodically check all fittings and re-tighten as necessary.
- To clean your item, please use a damp cloth and wipe clean. Never use harsh chemicals or strong detergents as this could damage the finish of your product.
- Never allow any kind of liquid to remain on your furniture. Absorption can cause wood to warp or finishes to de-laminate.
- Please do not place hot / cold item ( e.g. hot drinks ) directly on to the surface.
- Do not pull or drag your item. Ensure its evenly supported and lifted while moving it.
- Avoid placing sharp objects on the surface as this may scratch the surface. It is recommended to use trivets or coasters under flowerpots, vases and cups etc to avoid damage to your item.

# MONTREAL CUPBOARD SINGLE DOOR TALL

## ITEM CODE:61492

**PART LIST:**

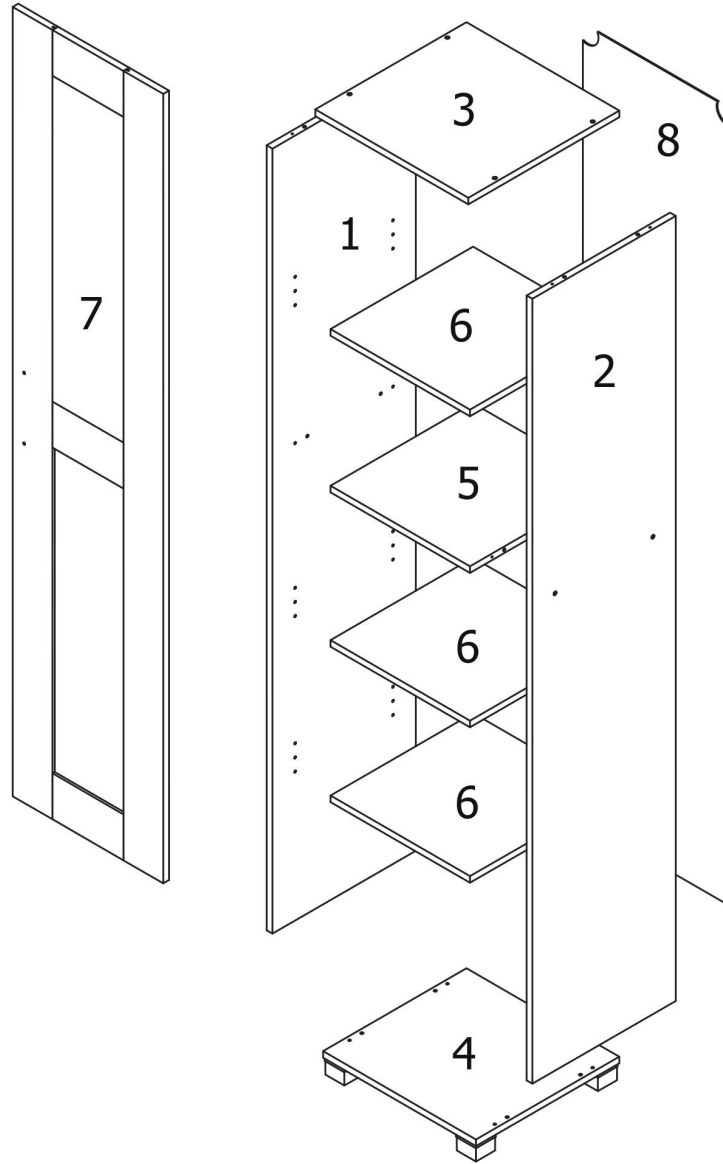













NO.	PART NAME	QTY
1	SIDE PANEL (LEFT)	1
2	SIDE PANEL (RIGHT)	1
3	TOP PANEL	1
4	BOTTOM PANEL	1
5	FIXED SHELF PANEL	1
6	ADJUSTABLE SHELF PANEL	3

NO.	PART NAME	QTY
7	DOOR PANEL	1
8	BACK PANEL	1

# MONTREAL CUPBOARD SINGLE DOOR TALL

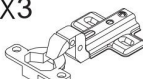
## ITEM CODE:61492

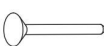
### HARDWARE LIST

<b>A</b> X8  SCREW COVER	<b>B</b> X12  DOWEL Ø6 X 25mm	<b>C</b> X12  SHELF SUPPORT	<b>D</b> X12  C/B SCREW M4 X 45MM
<b>E</b> X4  PVC SQ.LEG	<b>F</b> X28  C/B SCREW M3.5 X 16MM	<b>G</b> X1  PVC HANDLE	<b>H</b> X2  C/B SCREW M4 X 30MM
<b>I</b> X3  METAL HINGES	<b>J</b> X3  C/B SCREW M3.5 X 20MM	<b>K</b> X35  NAIL	<b>L</b> X2  L-BRACKET
<b>M</b> X2  C/B SCREW M3.5 X 12MM			

#### Tips before you start :

- Please check that all parts are present before you start the assembly of your furniture. Please do not start to build your item if any parts are damaged as this may void your warranty. Please contact the retailer immediately so they can advise what you should do.
- For ease and speed of assembly, we recommend that before you commence each step of the assembly, that you identify all the parts required for that step.

# MONTREAL CUPBOARD SINGLE DOOR TALL

ITEM CODE:61492

## STEP 1

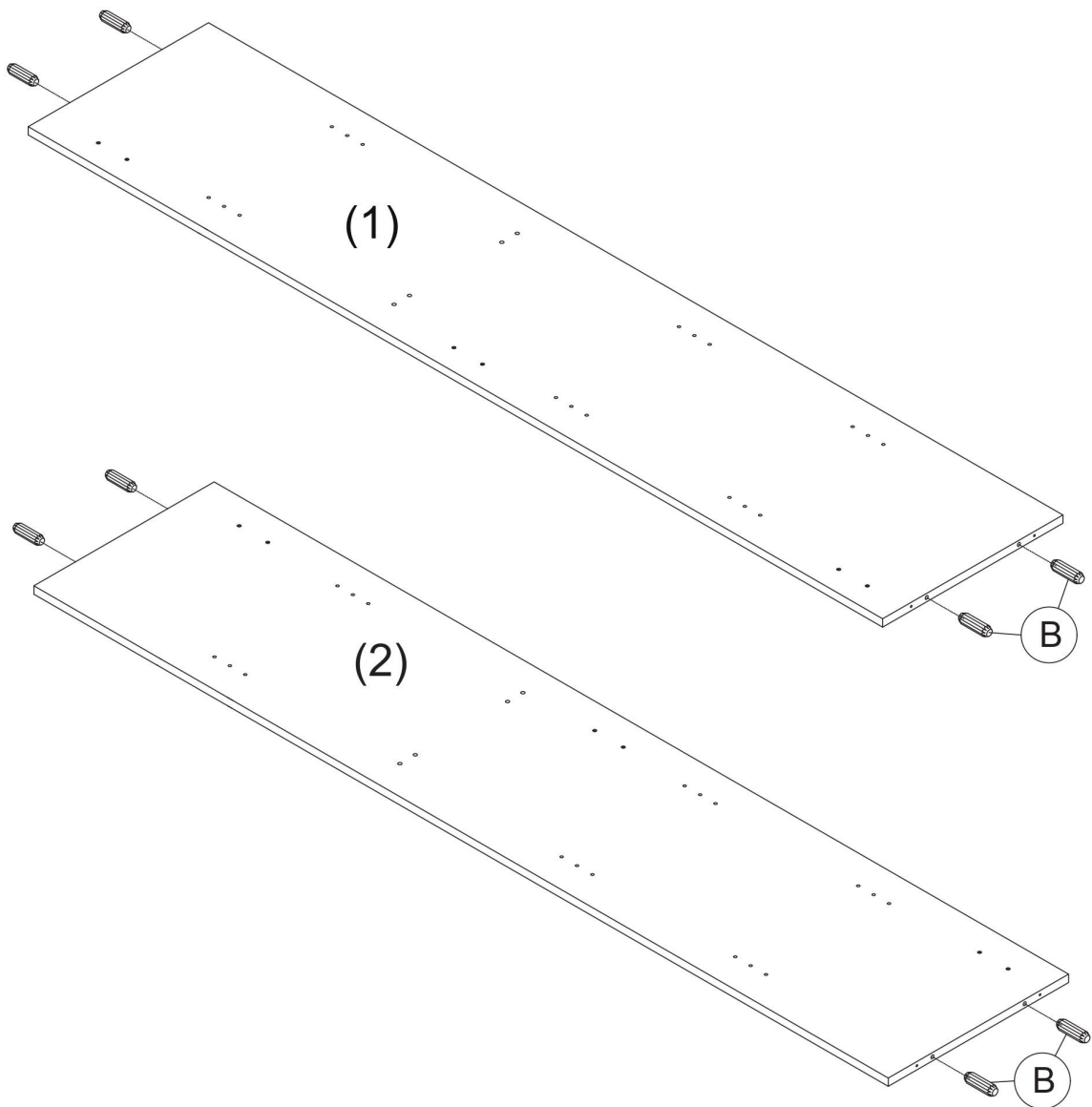

**B** = 8pcs

# MONTREAL CUPBOARD SINGLE DOOR TALL

## ITEM CODE:61492

### STEP 2

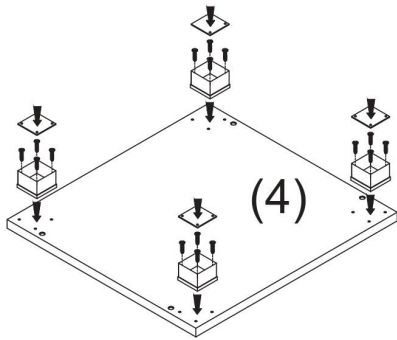

#### STEP 1

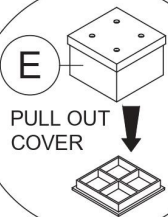

#### STEP 2

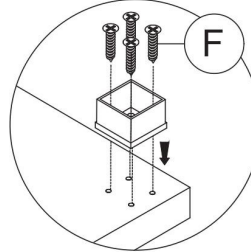

#### STEP 3

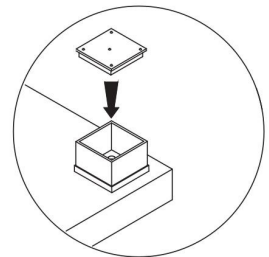

(E) = 4pcs (F) = 16pcs

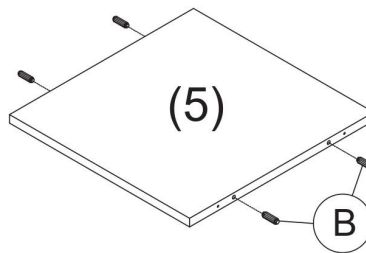

(B) = 4pcs

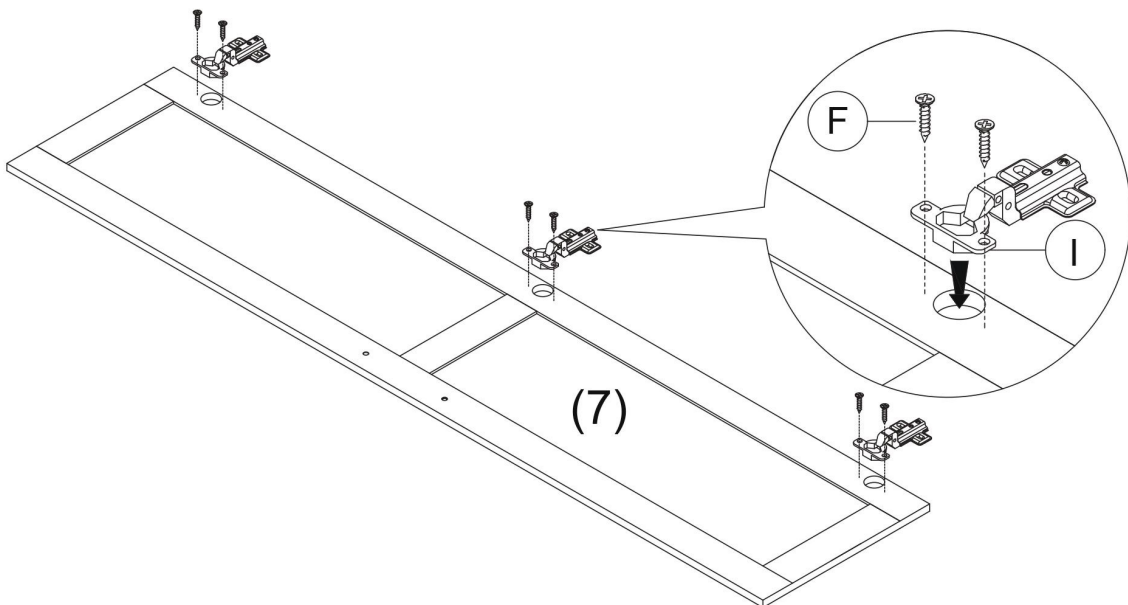

(F) = 6pcs (I) = 3pcs

**TIP :** To ensure the hinge plates are straight you could use the straight edge of another panel and place on top and position the edge against the hinge plates, ensure the panel is aligned properly with the door panel and double check all hinges are nice and straight before you tighten / secure the hinges onto the panel.

# MONTREAL CUPBOARD SINGLE DOOR TALL

## ITEM CODE:61492

### STEP 3

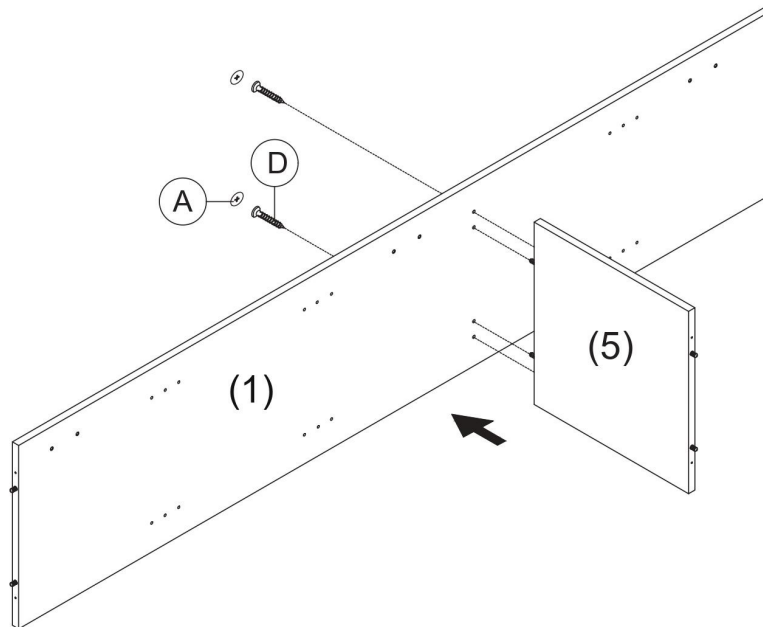

2 PERSON

Note: Its easier to have the help of a 2nd person to hold panels during this step and avoid damage to your item.

A=2pcs

D=2pcs

### STEP 4

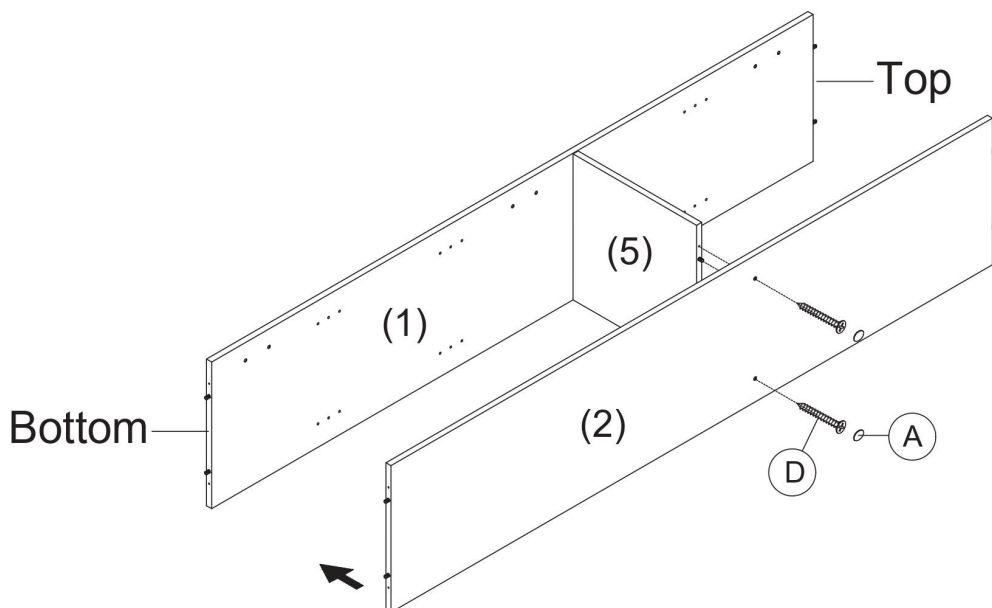

2 PERSON

Note: Its easier to have the help of a 2nd person to hold panels during this step and avoid damage to your item.

A=2pcs

D=2pcs

# MONTREAL CUPBOARD SINGLE DOOR TALL

ITEM CODE:61492

## STEP 5

**TIP :** Ensure that all Laminated edges are facing towards the front of the cabinet.

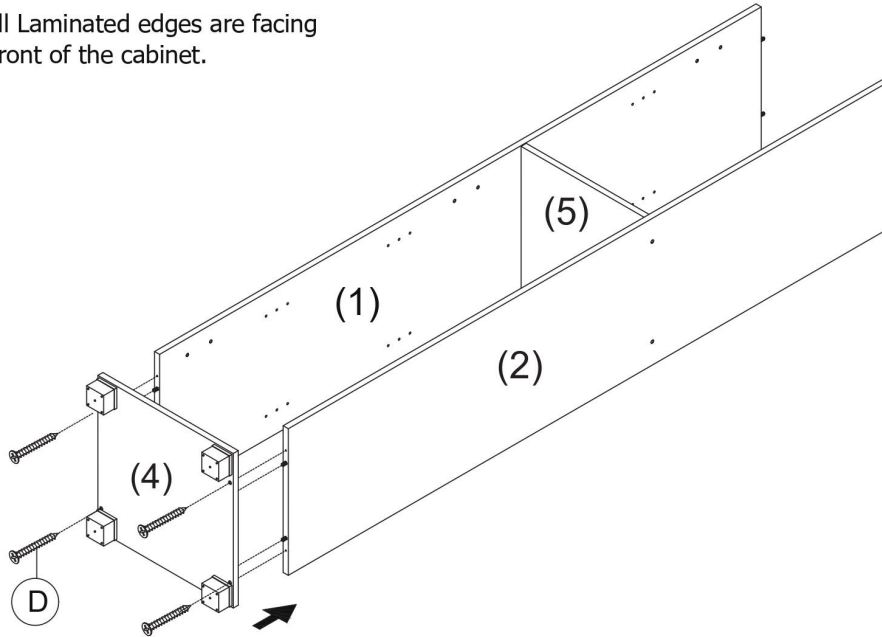

(D)=4pcs

## STEP 6

**TIP :** Ensure that all Laminated edges are facing towards the front of the cabinet.

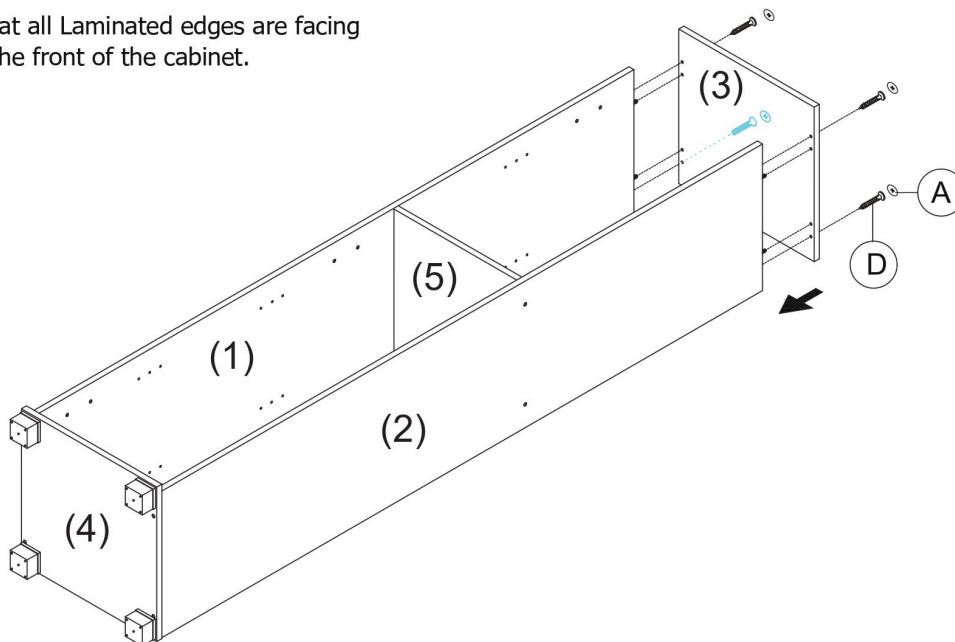

(A)=4pcs (D)=4pcs

# MONTREAL CUPBOARD SINGLE DOOR TALL

## ITEM CODE:61492

### STEP 7

#### TO FIX THE DOOR

The door can be hung on either the Left hand side or the Right hand side. Follow the diagram below based on which side you prefer to hang your door.

To attach your doors to the cabinet, align the door panel and hinge with the screw guide holes on the side panels. A 2nd person must help during this step. Attach the hinge plate with screws (F) as shown.

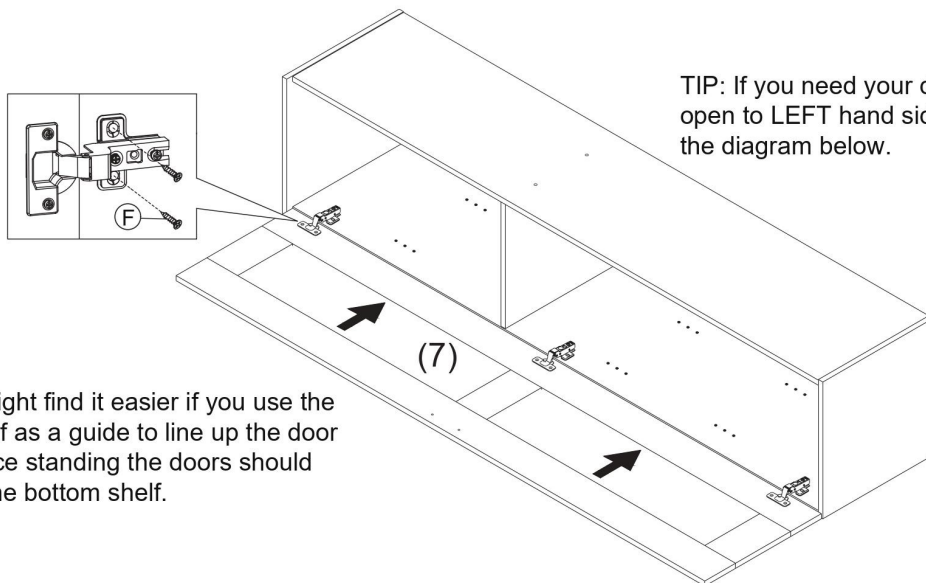

TIP: If you need your door to open to LEFT hand side follow the diagram below.

TIP: You might find it easier if you use the bottom shelf as a guide to line up the door panels. Once standing the doors should align with the bottom shelf.

TIP: If you need your door to open to RIGHT hand side follow the diagram below.

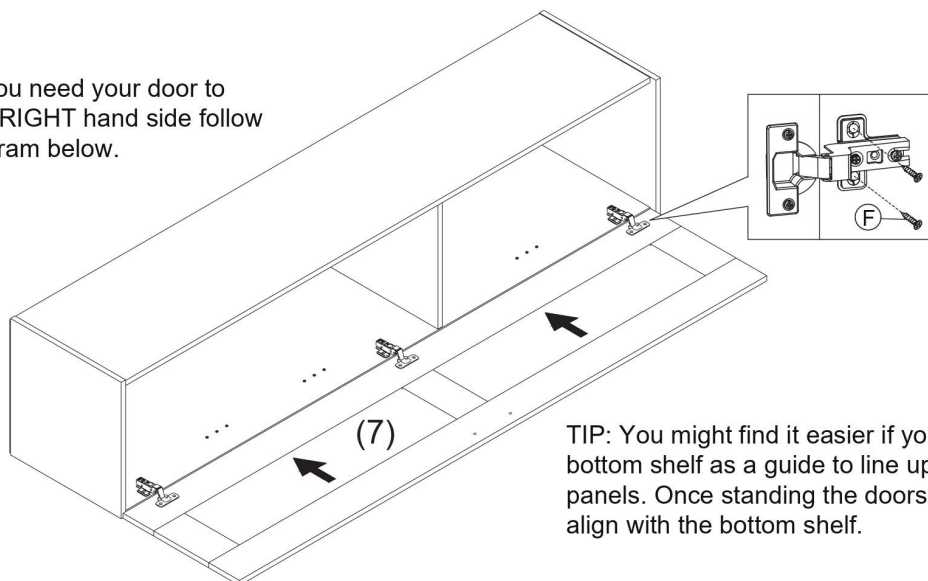

TIP: You might find it easier if you use the bottom shelf as a guide to line up the door panels. Once standing the doors should align with the bottom shelf.



Note: Make sure you support the door that had just been installed, and carefully turn over the cavity ready to attach the backing board in the next step.

F=6pcs

# MONTREAL CUPBOARD SINGLE DOOR TALL

## ITEM CODE:61492

### STEP 8

Place the back panel onto the cabinet and ensure the cut outs for the wall brackets are facing to the top, and that the laminated side of the panel is facing inwards. Mark the location of the nails (K) with a pencil then carefully secure nails with a hammer.

**TIP :** Before completing this step ensure all Laminated edges are facing towards the front, and the raw edges are facing to the back.

Use a pencil guide to mark the position of the nails so they are centered into the side panels and fixed shelf and avoids damage to your item.

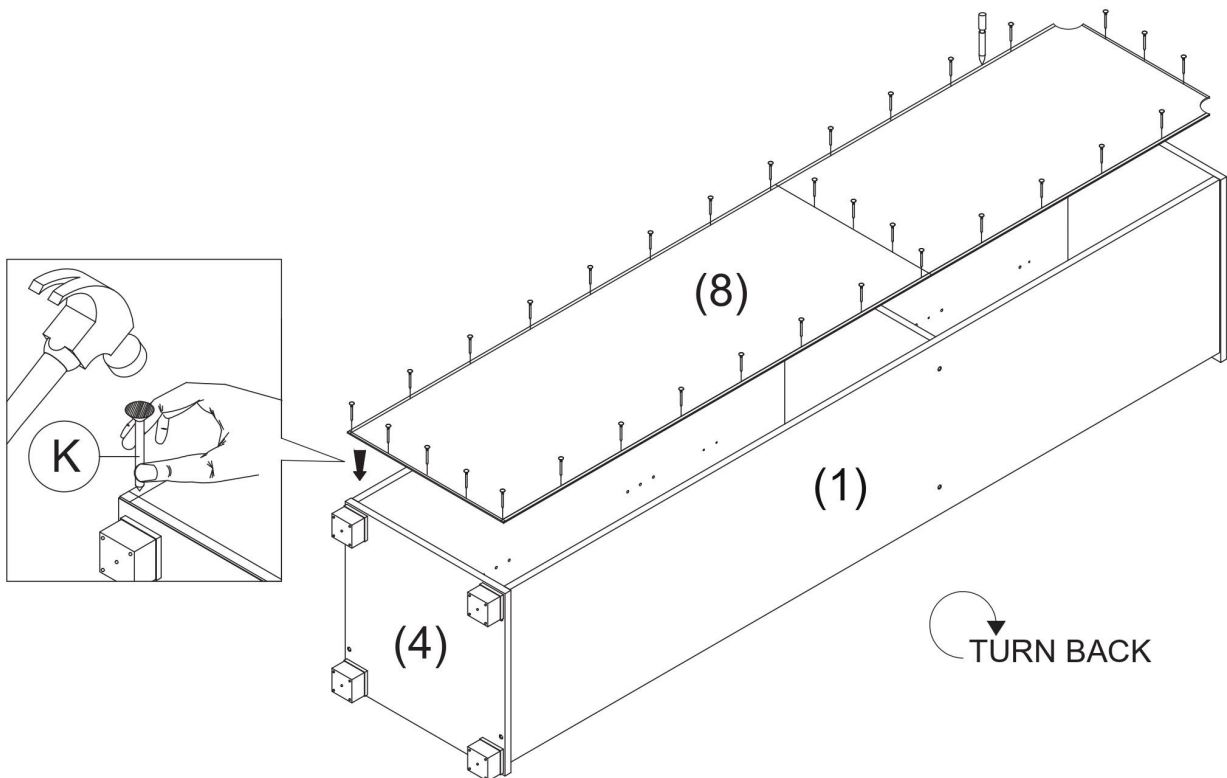

Note: With the help of a second person carefully turn your item over.

Ⓚ=35pcs

# MONTREAL CUPBOARD SINGLE DOOR TALL

## ITEM CODE:61492

### STEP 9

Insert the shelf supports (C) into the holes provided at your preferred shelf height. Ensure the shelf is firmly secured and correctly in position.

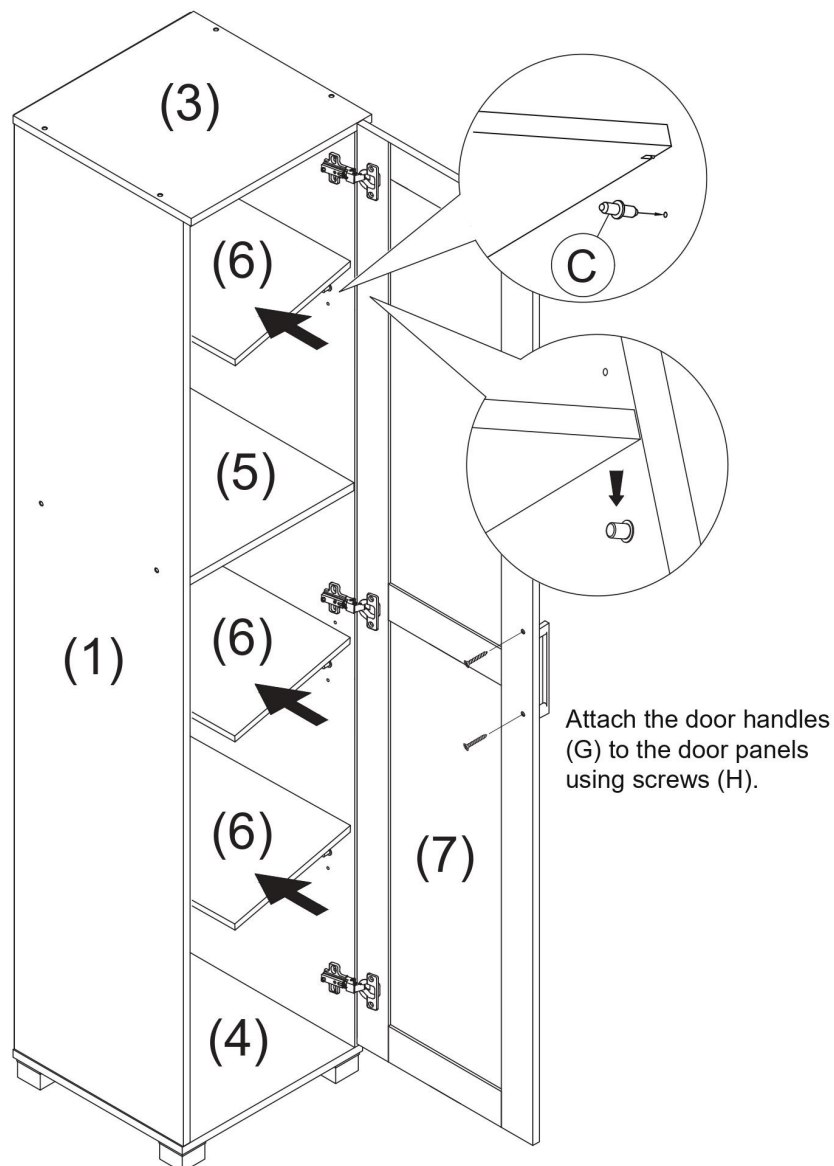

Note: With the help of a second person carefully turn your item over.

(C) = 12pcs (G) = 1pc (H) = 2pcs

# MONTREAL CUPBOARD SINGLE DOOR TALL

## ITEM CODE:61492

### STEP 10

Secure the L-Bracket (L) to the bottom of the panel No.3 with screws (M) as shown. If your hinges have been adjusted and you're happy with the door positions attach "J" screw into the hinge plate as shown.

#### IMPORTANT:

Weight Capacity per shelf is 6kg distributed evenly across the shelf

**IMPORTANT:** The "J" screw should only be secured once the doors have been adjusted and are properly into position.

**NOTE :** Ensure the J screw is positioned as this will further secure your hinges to the cabinet and strengthen the hinge.

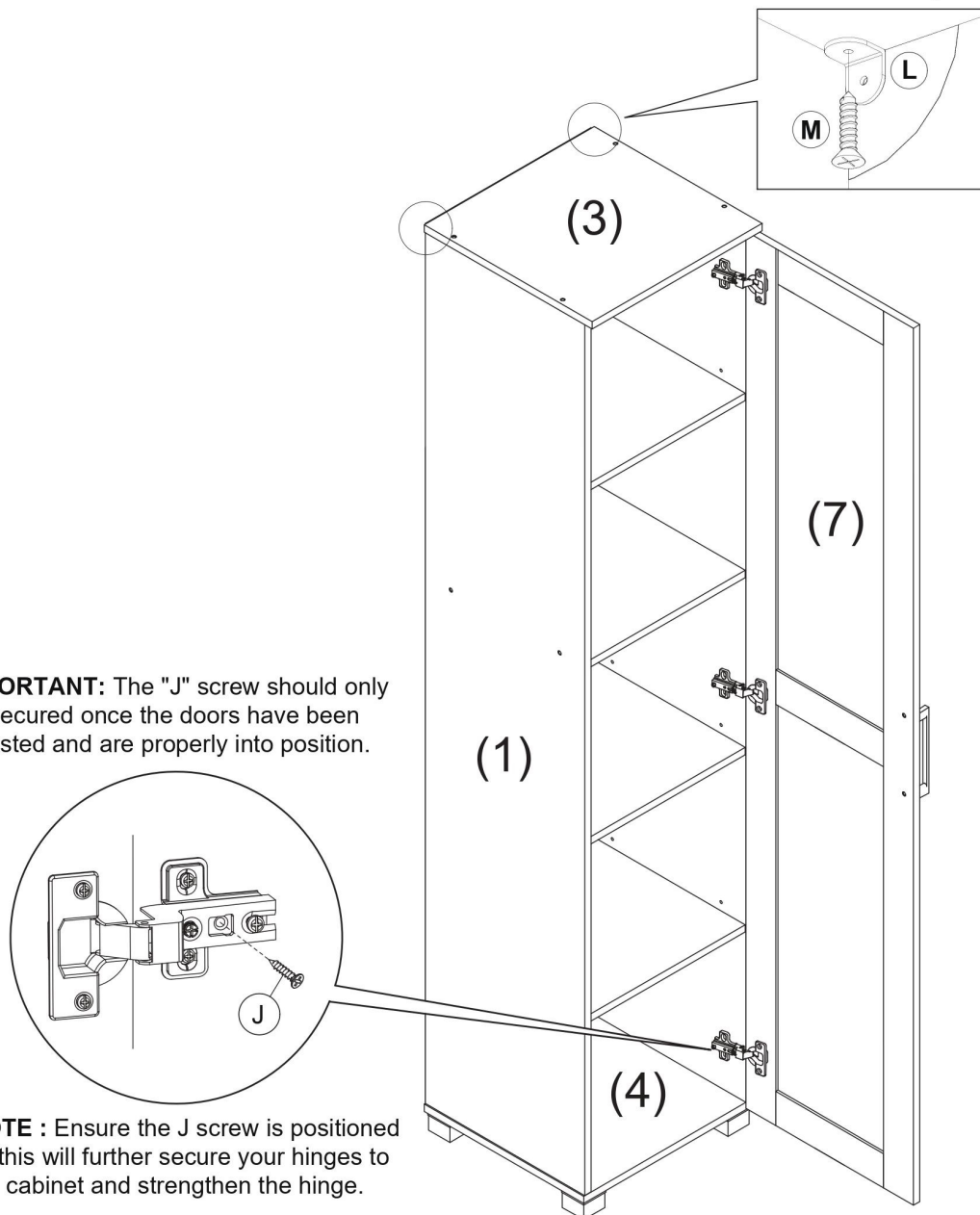

ⓐ=3pcs ⓑ=2pcs ⓒ=2pcs

# MONTREAL CUPBOARD SINGLE DOOR TALL

## ITEM CODE:61492

### HOW TO ADJUST YOUR HINGES AND ALIGN THE DOORS

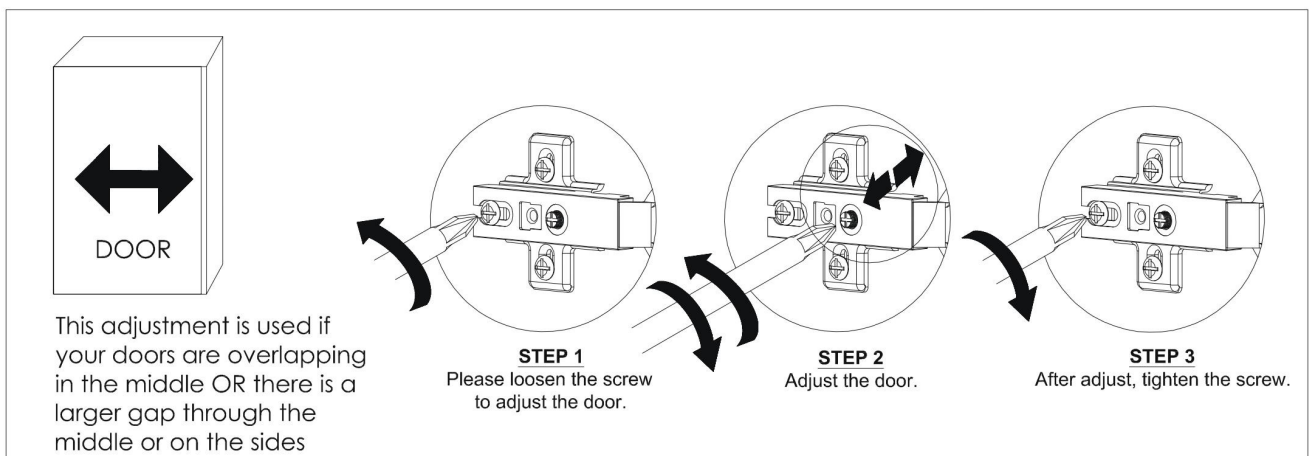

Follow the adjustments and make sure the middle pin is correctly installed as per previous instructions. If the middle pin isn't correctly installed then this adjustment will not work correctly.

If you tighten/loosen this screw it will adjust the doors to the left/right.

This step usually takes small adjustments and then closing doors to see if the gaps have evened out. Sometimes just half a turn of the screw can make a big impact to the gap.

The hinges are correctly installed and in position once you have a nice straight gap down the sides of the cupboard between the door and the side of the cupboard cavity.

# MONTREAL CUPBOARD SINGLE DOOR TALL

## ITEM CODE:61492

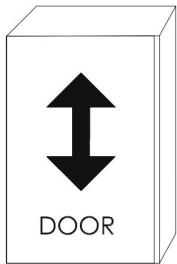

This adjustment is used if your doors have a big gap at the top or the bottom, or if one door sits straight but is lower than the other door.

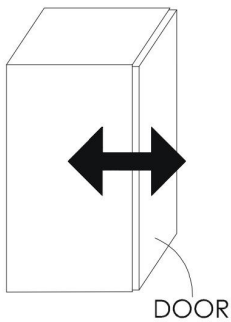
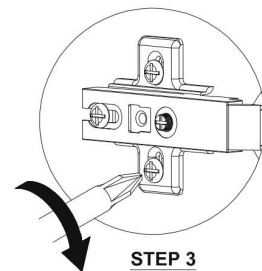
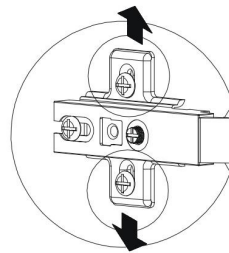
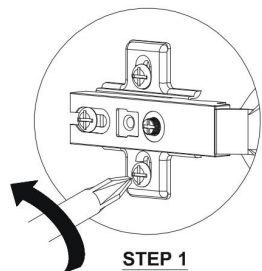

This adjustment is used if your doors are TOO CLOSE to the main cavity. You can loosen the screw and then move the door hinge closer or further out depending on the outcome you want to achieve

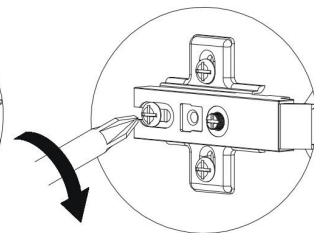
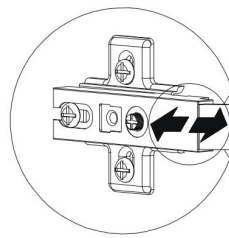
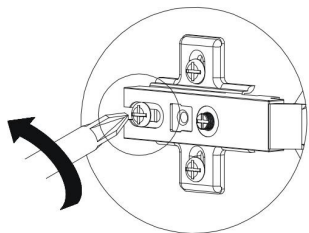

# MONTREAL CUPBOARD SINGLE DOOR TALL

## ITEM CODE:61492

### STEP 11

#### Bracket Fixing

The horizontal arms of the brackets are to be secured to the underside of shelf so that it is out of sight when the cabinet is installed into position.

- ☒ After assembling the unit place it against the wall where it will be permanently positioned.
- ☒ Working from inside the cabinet place the bracket through the pre-cut hole in the rear wall of the cabinet as shown in diagram.
- ☒ Use a pencil to mark through the screw hole in the bracket, where the bracket has to be attached to the wall.
- ☒ Move the cabinet away from the wall and secure the bracket to the wall at the marked position using a wall anchor suited to your wall surface.
- ☒ With the wall brackets in position, move the cabinet back to the wall allowing the horizontal arm of the bracket to enter into the cabinet through the pre-cut holes in the back wall of the cabinet.
- ☒ Then using the screw supplied, secure the horizontal arm of the brackets to the underside of the shelf.

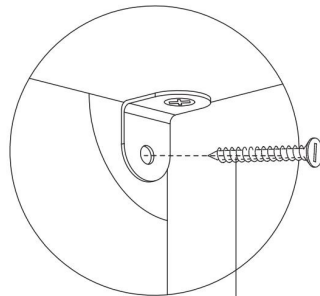

Screw used to attach to wall anchor is not provided. Purchase wall anchor and screw suited to the type of wall surface that the bracket is to be secured to.

#### WARNING:

##### ENSURE THAT WALL STRAP IS ATTACHED TO AVOID SERIOUS INJURY

To avoid any serious injury, this product has been supplied with a wall strap to prevent toppling.

We strongly recommend that this product is permanently fixed to the wall or other suitable surface.

Wall fixings hardware are not supplied as different surface materials require different types of fixing hardware & you must use suitable fixing hardware for type of wall you intend to mount this product to wall.

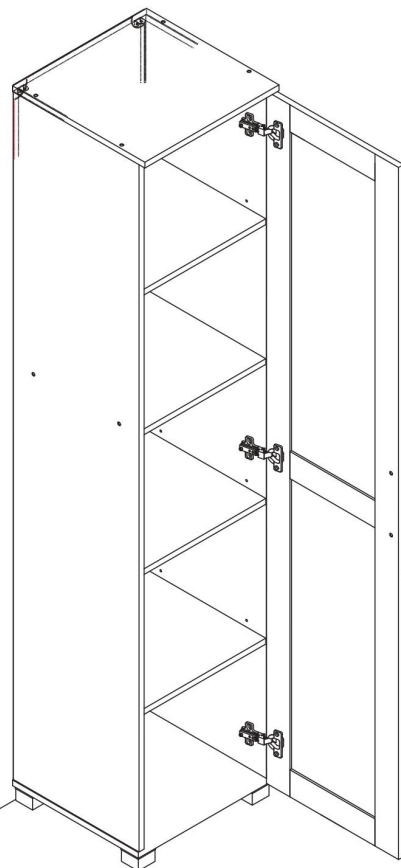

# Wall Mounting & Fixing Guide

**NOTE: Supplied wall plugs are only suitable for use in masonry walls.**

If you have any doubts about using the correct plug for your wall, please seek professional advice.

Failure of the product due to using incorrect fixings is the responsibility of the installer.



## IMPORTANT:

When drilling into walls, always check for hidden wires or pipes, etc.



## Tips & Tricks

**Make sure that the hardware used is suitable for supporting your unit.  
Please consult a qualified tradesperson if unsure.**

- If you are unsure, please select a larger screw and wall plug.
- Ensure that you use the recommended drill bit to match the wall plug and hole size.
- Take extra care when drilling high walls, ceiling and ceramic tiles. Ensure wall plugs are inserted beyond the thickness of the ceramic tiles to avoid splitting or cracking.
- Ensure that wall plugs are well fitted and are a tight fit in the drilled hole.

## Types Of Walls

Use one of the following types of wall plug (not included) if your walls are made of brick, breeze block, concrete, stone or wood. Screws may be able to be fixed directly to solid wood walls as they will provide a secure anchor point.

### 1. General purpose wall plug

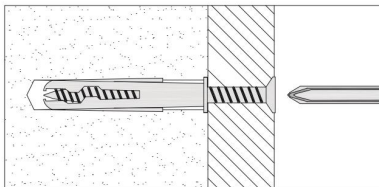

Generally aerated blocks should not be used to support heavy loads, use a specialist fitting in this case. For light loads, general purpose wall plugs can be used.

### 2. Plasterboard wall plug

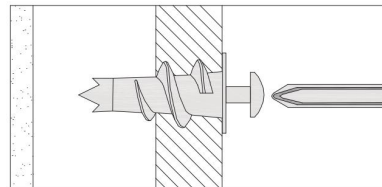

For use when attaching light loads on to plasterboard partitions or hollow wooden doors.

### 3. Cavity fixing wall plug

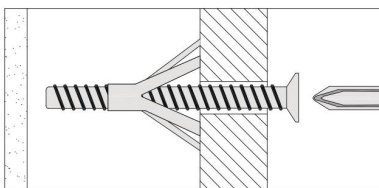

For use with plasterboard partitions or hollow wooden doors.

### 4. Cavity fixing-heavy duty wall plug

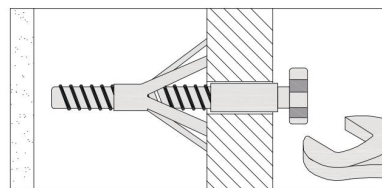

For use when fitting or supporting heavy loads such as shelving, wall cabinets and coat racks.

### 5. Hammer fixing wall plug

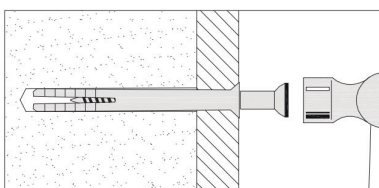

For use with walls stuck with plasterboard. The hammer fixing allows it to be fixed to the wall rather than the plasterboard. Always check the fixing is secure to the retaining wall.

### 6. Shield anchor wall plug - heavy loads

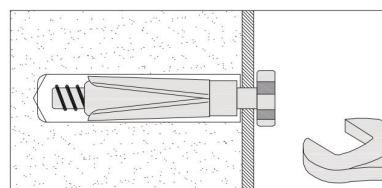

For use with heavier loads such as TV & HiFi speakers and satellite dishes etc.



**MEUBILAIR**  
DIRECT IMPORTS

## Warranty Certificate

---

**Congratulations!** You have made an excellent choice of this quality product. Our commitment to quality also includes our service. Should you, contrary to expectations, experience defects due to manufacturing faults, **Meubilair Direct Imports** will provide you with a warranty against defects as follows:

### Warranty

The product is guaranteed to be free from defects in workmanship and parts for a period of 12 months from the date of purchase. Defects that occur within this warranty period, under normal use and care, will be repaired, replaced or refunded at our discretion. The benefits conferred by this warranty are in addition to all rights and remedies in respect of the product that the consumer has under the Competition and Consumer Act 2010 and similar state and territory laws.

Our goods come with guarantees that cannot be excluded under the Australian Consumer Law. You are entitled to a replacement or refund for a major failure and for compensation for any other reasonably foreseeable loss or damage. You are also entitled to have the goods repaired or replaced if the goods fail to be of acceptable quality and the failure does not amount to a major failure.

### Proof of Purchase

This warranty is valid for the original purchase and is not transferable. Please keep your purchase docket, tax invoice or receipt as the best proof of purchase, and as proof of date on which the purchase was made.

### Normal Wear and Tear

This warranty does not cover normal wear and tear to the products or parts.

### Exclusions

This warranty does not cover:

- Any defects caused by an accident, misuse, abuse, improper installation or operation, lack of reasonable care, unauthorized modification, loss of parts, tampering or attempted repair by a person not authorized by the distributor.
- Any product that has not been installed, operated or maintained in accordance with the manufacturers' operating instructions provided with the product.
- Any product that has been used for purposes other than domestic use.
- Any damage caused by improper power input or improper cable connection.

### MEUBILAIR DIRECT IMPORTS PTY LTD

Customer Service

Email: [cs@meubilair.com.au](mailto:cs@meubilair.com.au)

Address: Unit 4, 16 Hickeys Road, Penrith, NSW, 2750

Opening hours: 9am to 4pm (Monday – Friday)

Contact Number: (02) 4701 5363

When making a return, please ensure the product is properly packaged, so as to ensure that no damage occurs to the product during transit. Please provide the original or a copy of the proof of purchase. Also please make sure you have included an explanation of the problem. Please note that the costs of making a warranty claim, including any return postage, will be covered by the supplier identified above. Please note upon receiving your warranty claim, the supplier will send, via the post or email, a repair and refurbished goods or parts notice. Please provide your email address and advise the supplier, if you wish to obtain a repair and refurbished goods or parts notice via email.

---

### AFTER SALES SUPPORT

EMAIL : [cs@meubilair.com.au](mailto:cs@meubilair.com.au)

Product code: 61492





**MEUBILAIR**  
DIRECT IMPORTS

## Warranty Certificate

PRODUCT NAME: Montreal Cupboard Single Door Tall

BRAND NAME:

PRODUCT CODE: 61492

NAME

ADDRESS

EMAIL

DAYTIME TEL NO

DATE OF PURCHASE

SERIAL NUMBER

We recommend that you attach a photocopy of your receipt, showing the date of purchase, to this Warranty certificate and **keep for your reference.**

In the event of a product fault, please email the Customer Service team. Please ensure that you include the product details (as shown on the card) at hand so that we are able to respond as quickly and efficiently as possible.

### MEUBILAIR DIRECT IMPORTS PTY LTD

Customer Service

Email: [cs@meubilair.com.au](mailto:cs@meubilair.com.au)

Address: Unit 4, 16 Hickeys Road, Penrith, NSW, 2750

Opening hours: 9am to 4pm (Monday – Friday)

Contact Number: (02) 4701 5363

### AFTER SALES SUPPORT

EMAIL : [cs@meubilair.com.au](mailto:cs@meubilair.com.au)

Product code: 61492

