

RICO 2 DRAWER 5 COMPARTMENT EXECUTIVE DESK

ITEM CODE: 2409-WHT/LSO

1.5 HR

APPROXIMATE ASSEMBLY TIME

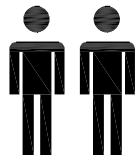

2 PERSON ASSEMBLY

FLOOR AREA
2.5M X 2.0M

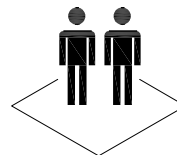

REQUIRED ASSEMBLY SPACE

REQUIRED ASSEMBLY TOOLS

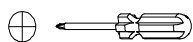

POZI SCREWDRIVER

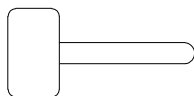

HAMMER

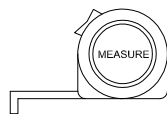

MEASURING TAPE



DRILL

ASSEMBLED DIMENSIONS

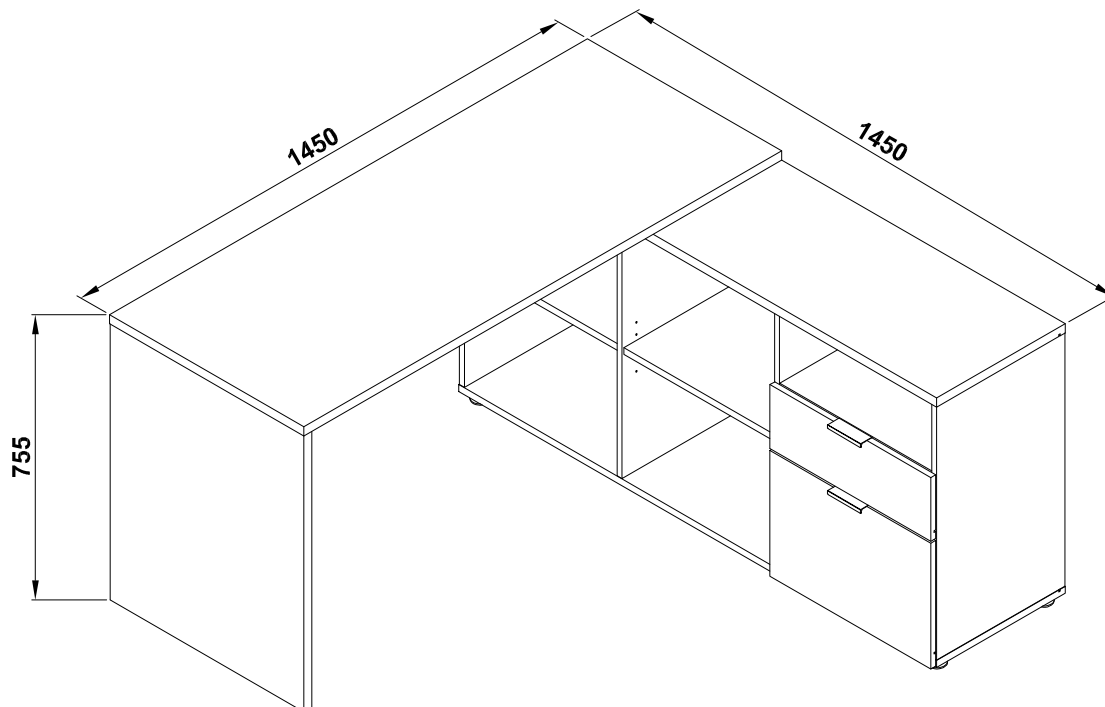

RICO 2 DRAWER 5 COMPARTMENT EXECUTIVE DESK

ITEM CODE: 2409-WHT/LSO

Important :

Please read these instructions carefully before use and keep for future reference.

- This product is intended for domestic use only and is not designed for commercial use.
- DO NOT assembly / use this item if any components are missing or damaged. Please contact the retailer straight away.
- DO NOT attempt to modify your item as this will void your warranty. Please call the retailer for required parts.
- Assembly to be carried out by a competent adult only.
- During assembly children should be kept away from the product due to possible risk of injury.

Please refer to separate Warranty Certificate for full warranty details and information.

Tips before you start :

- Please check that all parts are present before you start the assembly of your furniture. Please do not start to build your item if any parts are damaged as this may void your warranty. Please contact the retailer immediately so they can advise what you should do.
- For ease and speed of assembly, we recommend that before you commence each step of the assembly, that you identify all the parts required for that step.

RICO 2 DRAWER 5 COMPARTMENT EXECUTIVE DESK

ITEM CODE: 2409-WHT/LSO

Assembly Tips:

1. For larger items, please ensure that you have sufficient space and people (as indicated on page 1) to assemble your product safely.
2. We recommend that, where possible, all items are assembled near to the area in which they will be placed in use, to avoid moving the product unnecessarily once assembled.
3. For the protection of your furniture, we recommend that the product is placed on a protected surface during assembly to prevent any damage.
4. During assembly please take care not to over-tighten any fittings, as this may damage the product.
5. Always place the product on a flat, steady and stable surface.
6. Do not stand on the product. Do not use the product as a stepladder.
7. This product is intended for indoor, household use only as it is a non-industrial product.
8. Use of power tools is NOT recommended for assembling this product as over-tightening may occur and damage the product.
9. Due to the laminated finish of this item and the materials used to construct it, when first opening the carton and assembling a slight smell may be noticeable. This will dissipate over a short period of time. Please contact the retailer you purchased this item from if you have any concerns.
10. Please use caution and care when lifting the product to avoid personal injury and / or damage.

Care and Maintenance of your Furniture

- Please periodically check all fittings and re-tighten as necessary.
- To clean your item, please use a damp cloth and wipe clean. Never use harsh chemicals or strong detergents as this could damage the finish of your product.
- Never allow any kind of liquid to remain on your furniture. Absorption can cause wood to warp or finishes to de-laminate.
- Please do not place hot / cold items (e.g. hot drinks) directly on to the surface.
- Do not pull or drag your item. Ensure it is evenly supported and lifted while moving it.
- Avoid placing sharp objects on the surface as this may scratch the surface. It is recommended to use trivets or coasters under flowerpots, vases and cups etc to avoid damage to your item.

RICO 2 DRAWER 5 COMPARTMENT EXECUTIVE DESK

ITEM CODE: 2409-WHT/LSO

Tips before you start:

QUICKFIT

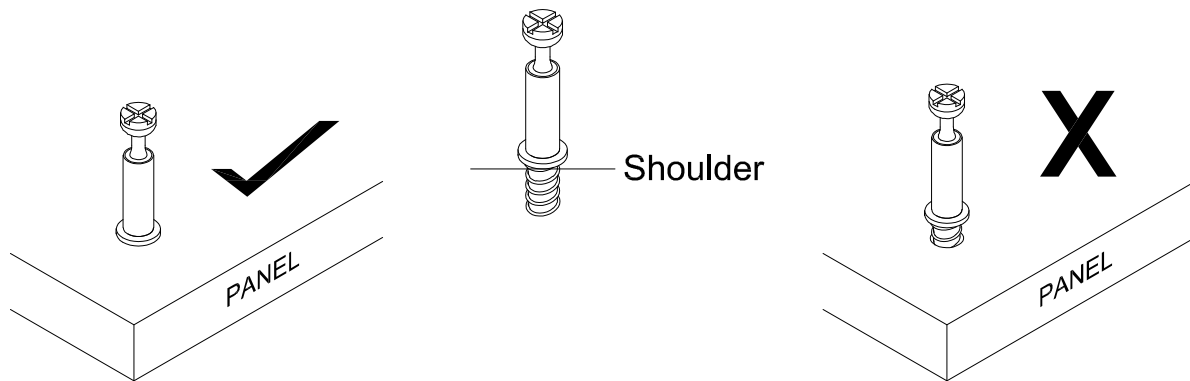

Tighten quickfit until shoulder is flush with panel. Do not overtighten or undertighten.

CAM LOCK

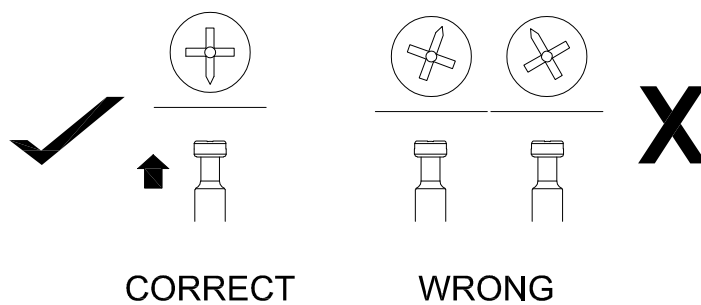

When fitting cam lock, ensure starting position is correct before you insert connecting quickfit.

Quickfit head should be in the centre of the cam lock when the two panels are joined.

Cam lock should be inserted before quickfit.

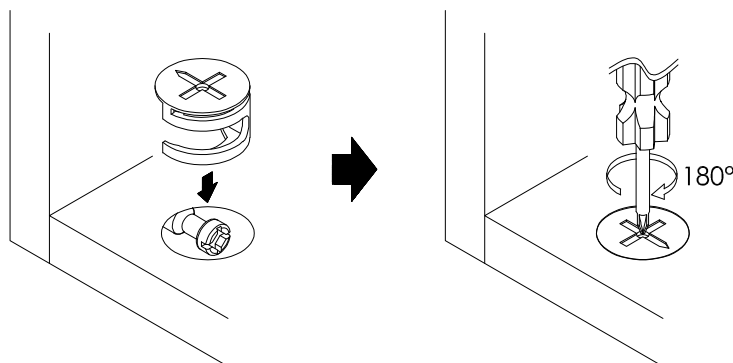

Turn camlock clockwise to tighten.

RICO 2 DRAWER 5 COMPARTMENT EXECUTIVE DESK

ITEM CODE: 2409-WHT/LSO

PART LIST:

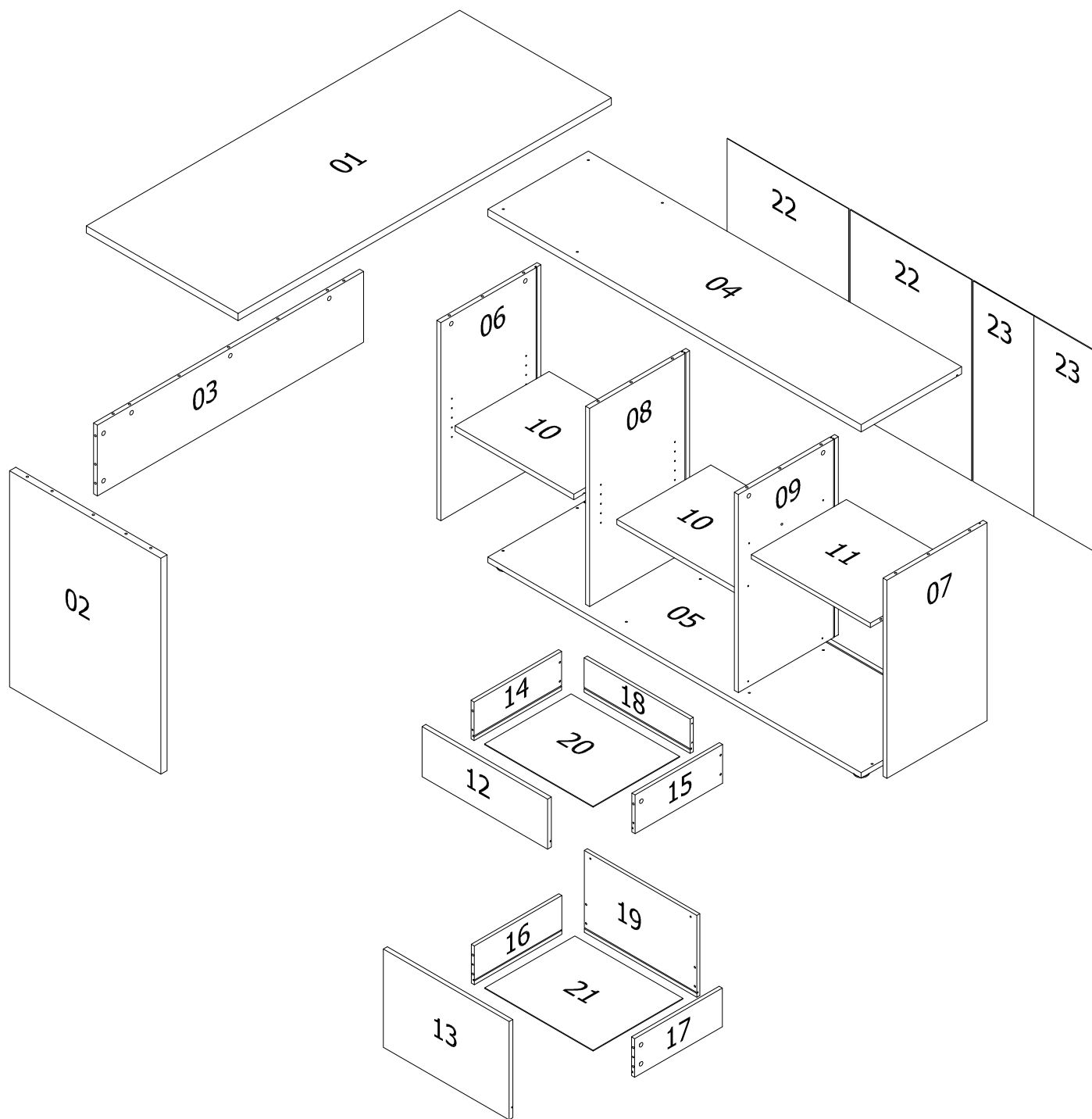

RICO 2 DRAWER 5 COMPARTMENT EXECUTIVE DESK

ITEM CODE: 2409-WHT/LSO

PART LIST:











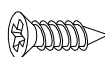
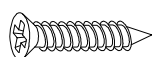

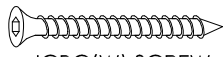

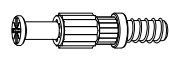

NO.	PART NAME	QTY
1	TOP PANEL (LEFT)	1
2	SIDE PANEL (LEFT)	1
3	BACK (LEFT) PANEL	1
4	TOP PANEL (RIGHT)	1
5	BOTTOM PANEL	1
6	SIDE PANEL (CENTER)	1
7	SIDE PANEL (RIGHT)	1
8	DIVIDER PANEL (LEFT)	1
9	DIVIDER PANEL (RIGHT)	1
10	ADJUSTABLE SHELF PANEL	2
11	FIXED SHELF PANEL	1
12	DRAWER FRONT (TOP)	1

NO.	PART NAME	QTY
13	DRAWER FRONT (BOTTOM)	1
14	DRAWER SIDE (TOP LEFT)	1
15	DRAWER SIDE (TOP RIGHT)	1
16	DRAWER SIDE (BOTTOM LEFT)	1
17	DRAWER SIDE (BOTTOM RIGHT)	1
18	DRAWER BACK (TOP)	1
19	DRAWER BACK (BOTTOM)	1
20	DRAWER BOTTOM (TOP)	1
21	DRAWER BOTTOM (BOTTOM)	1
22	BACK PANEL (LEFT)	2
23	BACK PANEL (RIGHT)	2

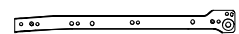
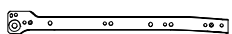
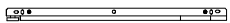
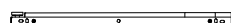
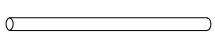
RICO 2 DRAWER 5 COMPARTMENT EXECUTIVE DESK

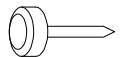
ITEM CODE: 2409-WHT/LSO

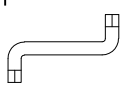
HARDWARE LIST

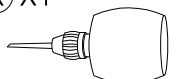
<p>A X8</p>  <p>CSK SCREW M3.5 X 12MM</p>	<p>B X36</p>  <p>CSK SCREW M3.5 X 15MM</p>	<p>C X6</p>  <p>CSK SCREW M4 X 30MM</p>	<p>D X8</p>  <p>EURO SCREW M6 X 9MM</p>
<p>E X8</p>  <p>JCBC(W) SCREW M6 X 40MM</p>	<p>F X4</p>  <p>JCBC SCREW M6 X 30MM</p>	<p>G X8</p>  <p>UNITAR SCREW M6.3 X 45MM</p>	<p>H X4</p>  <p>WOOD DOWEL Ø6 X 20MM</p>
<p>J X13</p>  <p>WOOD DOWEL Ø8 X 25MM</p>	<p>K X26</p>  <p>9047975 BOLT DOWEL DU319 20X5MM</p>	<p>L X20</p>  <p>9064684 CAM 15/15</p>	<p>M X6</p>  <p>9064684 CAM 15/12</p>
<p>N X2</p>  <p>ALUMINIUM U SHAPE HANDLE (100 X 64MM)=(1PC) WITH SCREW (M3.5 X15MM)=(2PCS)</p>	<p>P1 X2</p>  <p>METAL DRAWER SLIDE CR (350MM)</p>	<p>P2 X2</p>  <p>METAL DRAWER SLIDE CL (350MM)</p>	<p>Q X2</p>  <p>METAL DRAWER SLIDE DR (350MM)</p>
<p>Q2 X2</p>  <p>METAL DRAWER SLIDE DL (350MM)</p>	<p>R X2</p>  <p>WIRE ROD (Ø5 X 360)</p>	<p>S X6</p>  <p>SOFA LEG</p>	<p>T X2</p>  <p>PLASTIC LEG STUD</p>
<p>U X8</p>  <p>METAL ADJUSTABLE SHELF STUD</p>	<p>V X1</p>  <p>ALLEN KEY M4</p>	<p>W X36</p>  <p>BACKPLY STOPPER</p>	<p>X X1</p>  <p>GLUE</p>

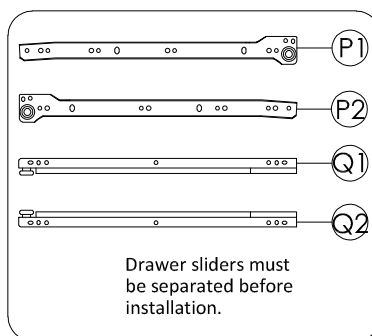

Drawer sliders must be separated before installation.

P1 & P2 / Q1 & Q2

RICO 2 DRAWER 5 COMPARTMENT EXECUTIVE DESK

ITEM CODE: 2409-WHT/LSO

STEP 1

Using glue (X) insert dowel (H & J) into pieces (2, 3, 6, 7, 8, 9, 11, 14, 15, 16 & 17) as shown.

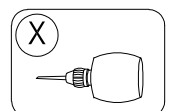
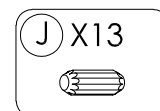
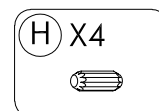
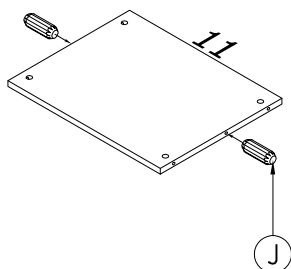
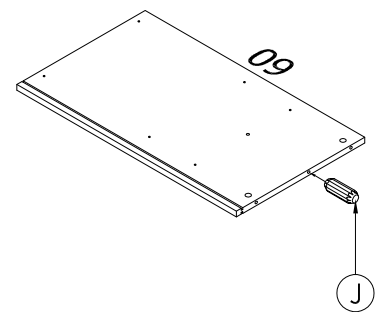
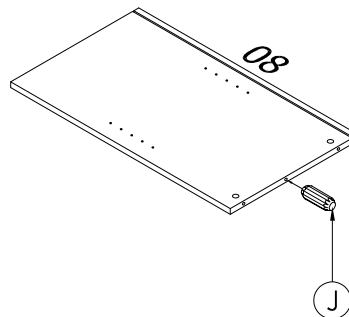
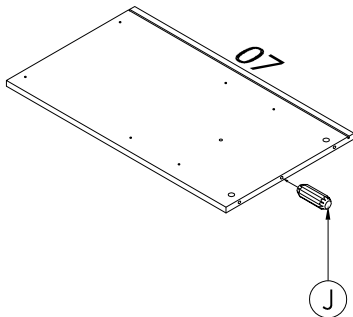
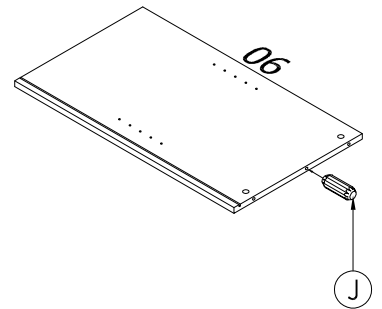
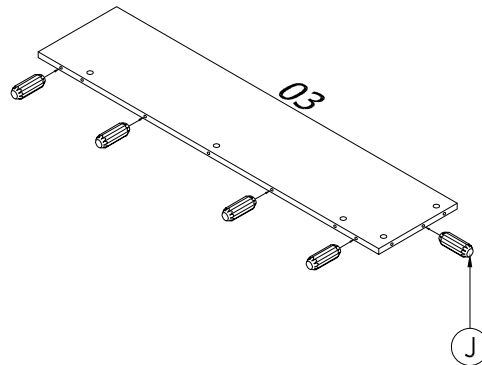
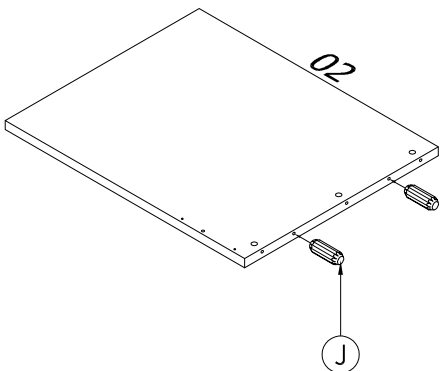
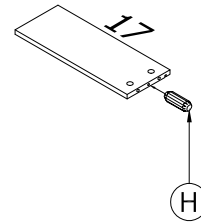
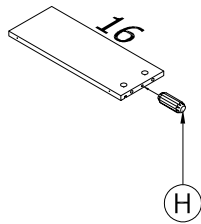
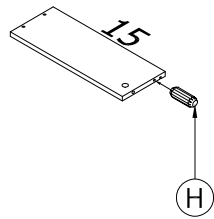
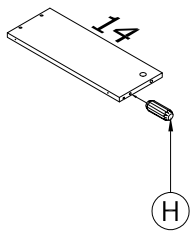
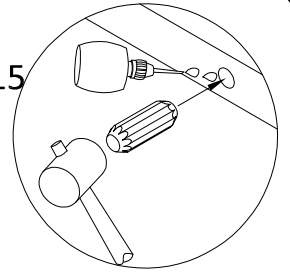

RICO 2 DRAWER 5 COMPARTMENT EXECUTIVE DESK

ITEM CODE: 2409-WHT/LSO

STEP 2

Take all panels (1, 2, 4, 7, 9, 12 & 13), using a phillips head screw driver cam pins (K) as shown.

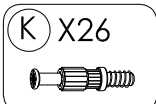
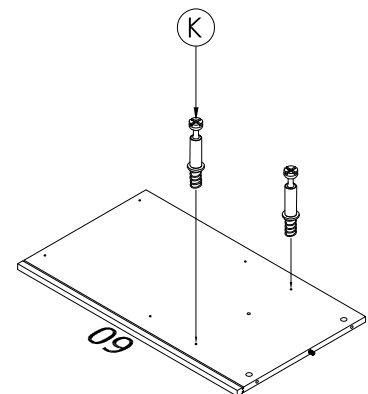
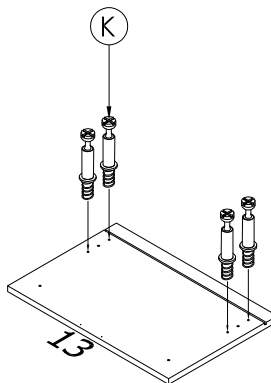
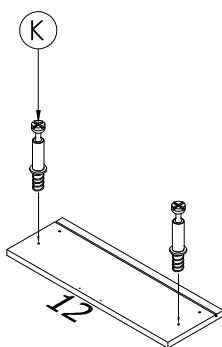
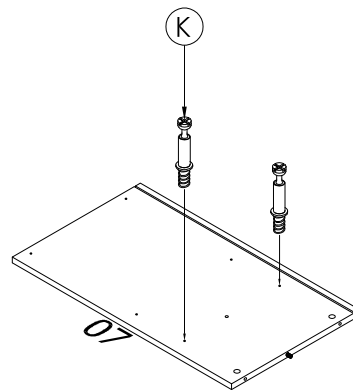
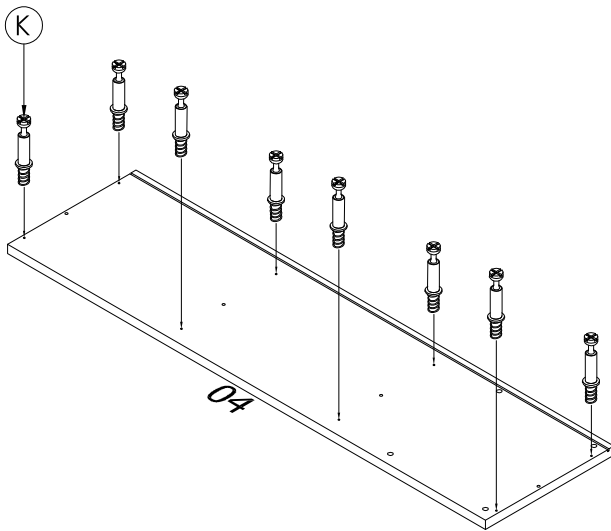
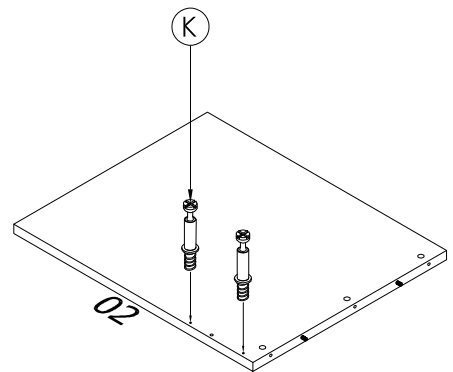
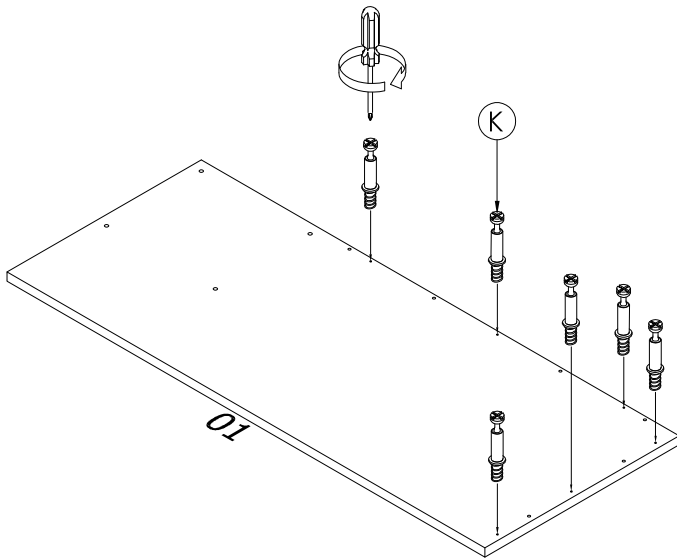

RICO 2 DRAWER 5 COMPARTMENT EXECUTIVE DESK

ITEM CODE: 2409-WHT/LSO

STEP 3

Attach drawer side (14 & 15) to drawer (18) using 40mm screw (E).

Note: Its important not to over-tighten screws on the drawer sides until all sides are aligned and the drawer base is inserted. Tighten screws fully once base is inserted correctly. Always keep drawer flat in this step so the groove for base will align correctly.

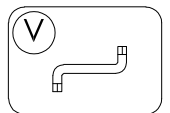
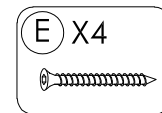
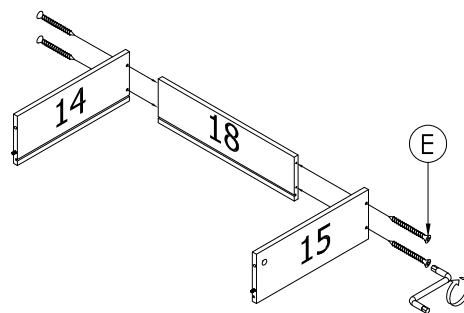
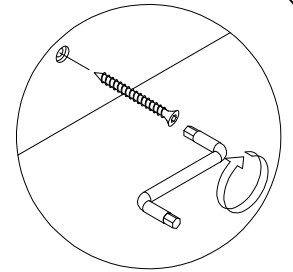

STEP 4

Slot drawer bottom (20) into drawer frame.

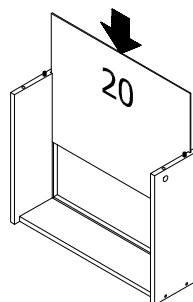

RICO 2 DRAWER 5 COMPARTMENT EXECUTIVE DESK

ITEM CODE: 2409-WHT/LSO

STEP 5

Using glue (X) attach drawer front (12) to drawer body. Fasten into place using cam lock (M) as shown.

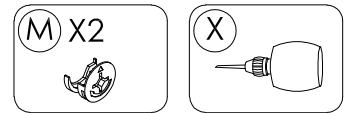
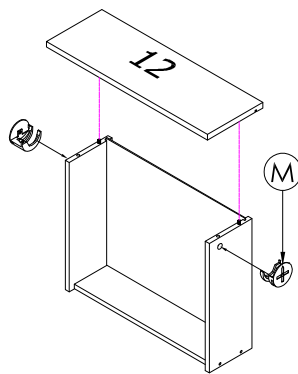
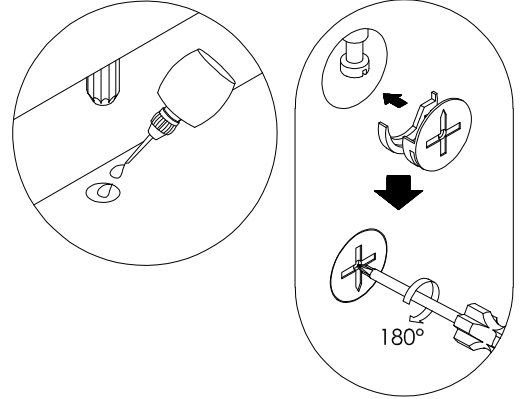

STEP 6

Affix the handle (N) to drawer front (12) with 15mm as shown.

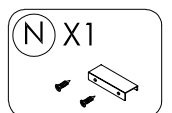
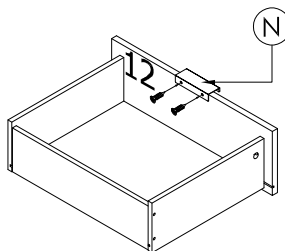

RICO 2 DRAWER 5 COMPARTMENT EXECUTIVE DESK

ITEM CODE: 2409-WHT/LSO

STEP 7

Attach the drawer slide inserts (Q1 & Q2) to the base of the drawer side (14 & 15) with the 12mm screw (A) as shown.

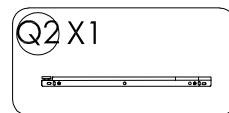
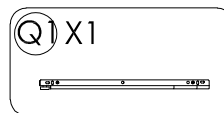
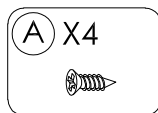
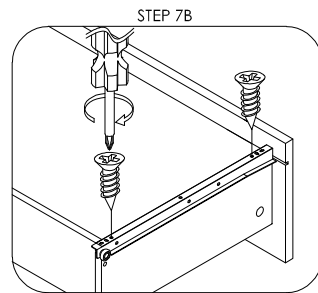
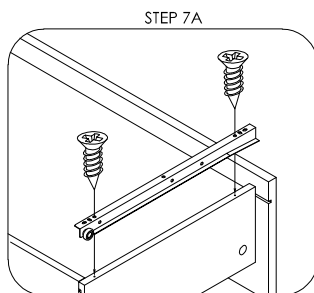
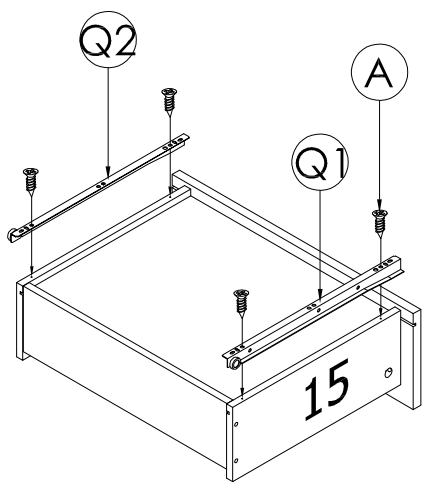

STEP 8

Using glue (X) attach drawer front (13) to drawer body. Fasten into place using cam lock (M) as shown.

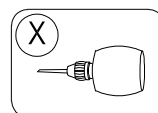
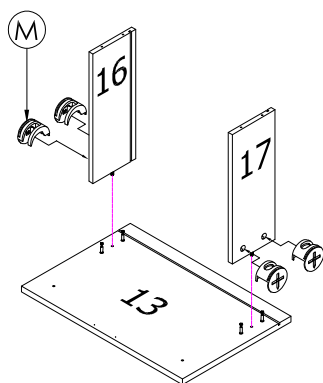
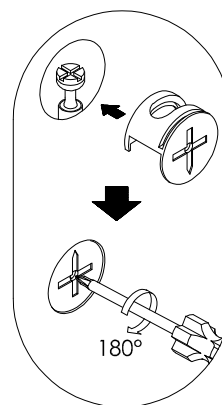
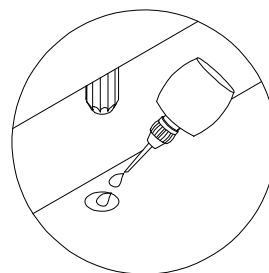

RICO 2 DRAWER 5 COMPARTMENT EXECUTIVE DESK

ITEM CODE: 2409-WHT/LSO

STEP 9

Slot drawer bottom (21) into drawer frame.

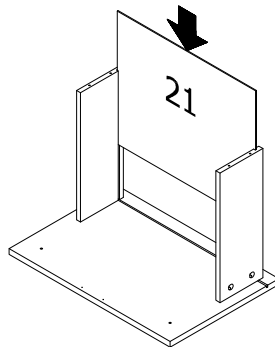

STEP 10

Insert wire rod (R) on to drawer front (13 & 19) drawer back (19) hole as shown, together attach drawer back (19) to side (16 & 17) of drawer using 40mm screw (E) with allen key (V).

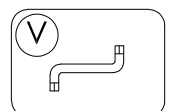
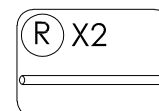
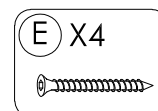
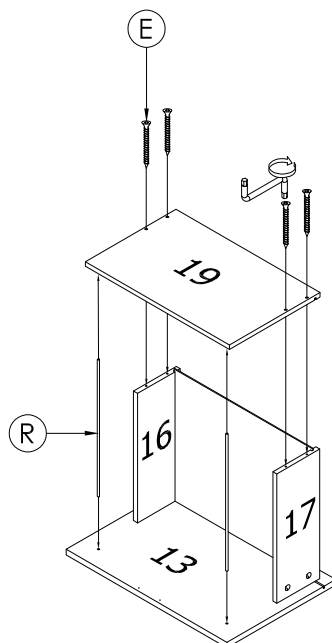
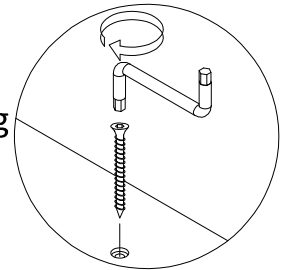

RICO 2 DRAWER 5 COMPARTMENT EXECUTIVE DESK

ITEM CODE: 2409-WHT/LSO

STEP 11

Affix the handle (N) to drawer front (13) with 15mm as shown.

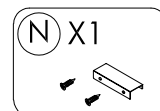
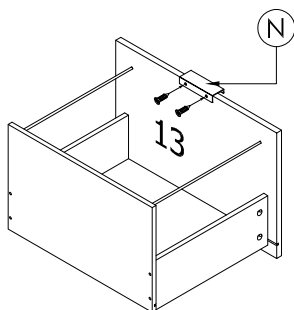

STEP 12

Attach the drawer slide inserts (Q1 & Q2) to the base of the drawer side (16 & 17) with the 12mm screw (A) as shown.

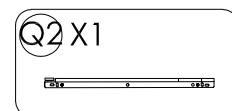
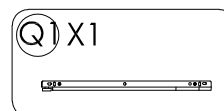
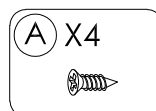
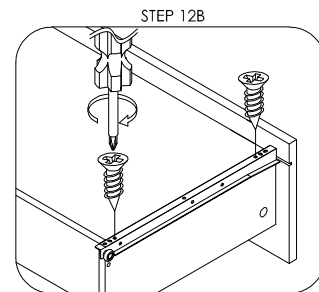
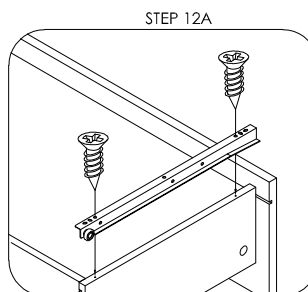
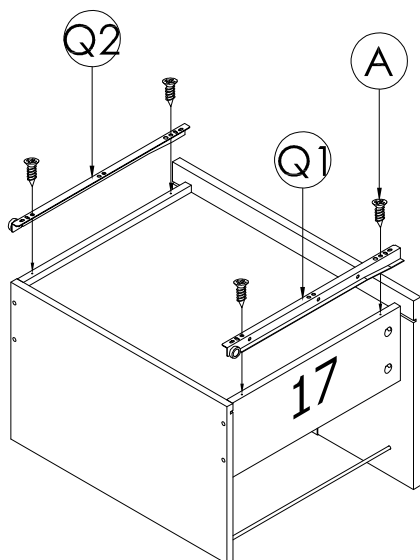

RICO 2 DRAWER 5 COMPARTMENT EXECUTIVE DESK

ITEM CODE: 2409-WHT/LSO

STEP 13

Take both side panel (7 & 9) attach drawer slide casing (P1 & P2) using screw 9mm (D) as shown.

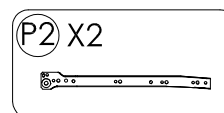
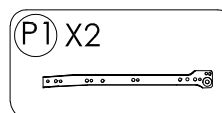
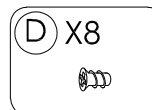
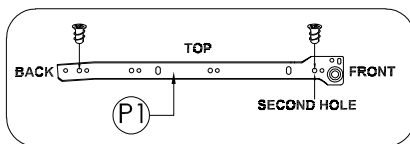
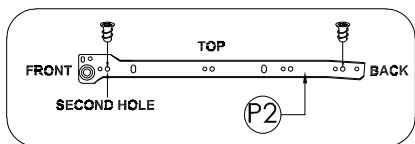
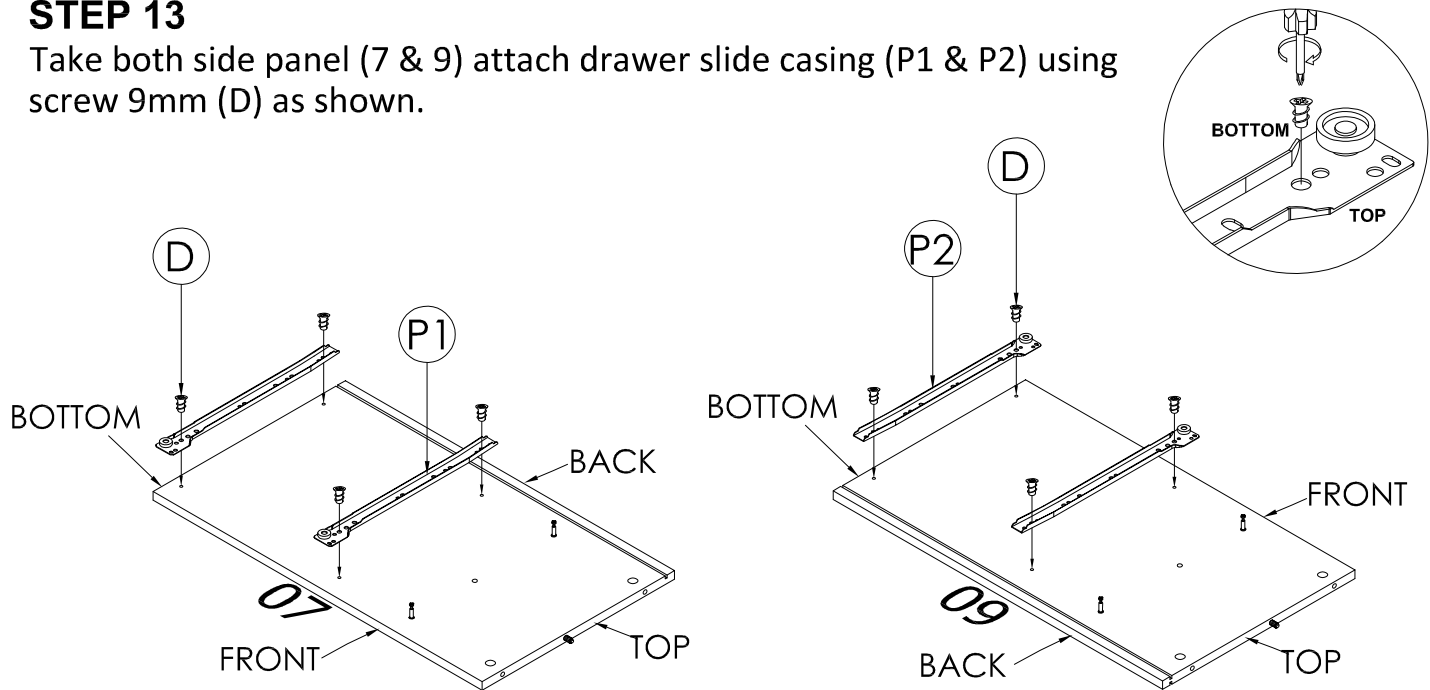

PLEASE ENSURE YOU FOLLOW THE SCREW HOLE PATTERN ON THE DIAGRAM FOR CORRECT ASSEMBLY OF THE DRAWERS.

STEP 14

Attach panels (7 & 9) to panel (11) using glue (X) and cam lock (L) as shown.

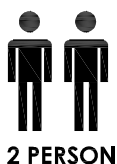
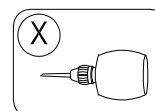
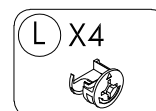
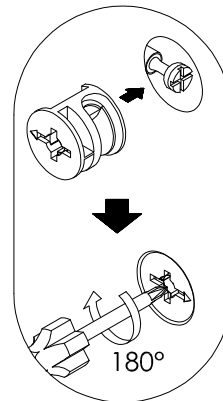
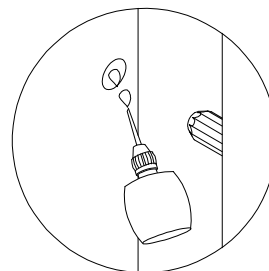
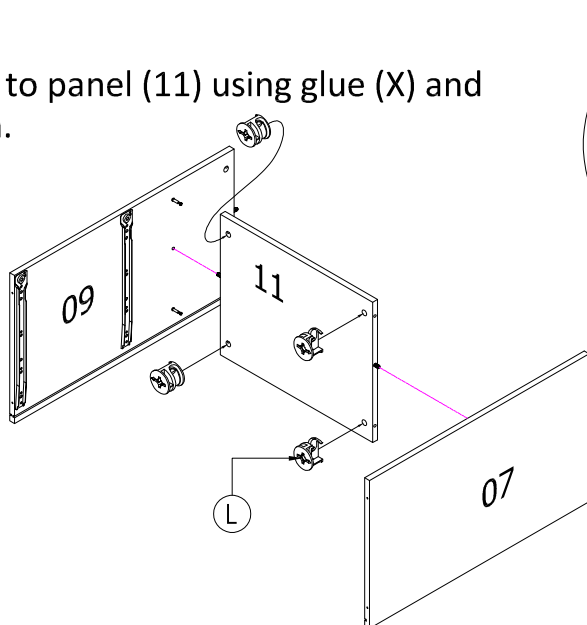

RICO 2 DRAWER 5 COMPARTMENT EXECUTIVE DESK

ITEM CODE: 2409-WHT/LSO

STEP 15

Attach bottom panel (5) to side & divider panel (6, 7, 8 & 9) using screw (G) with allen key (W) as shown.

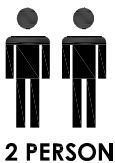
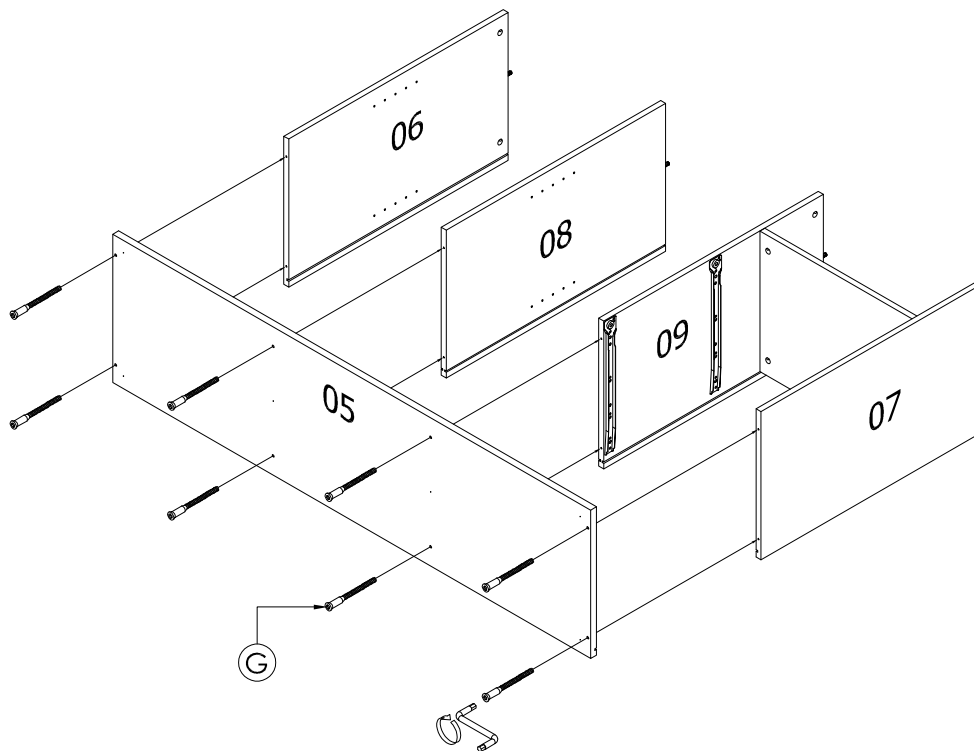
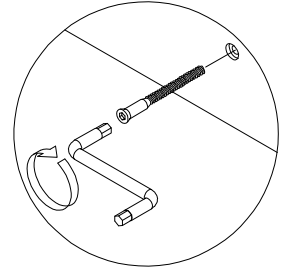

2 PERSON

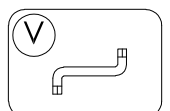
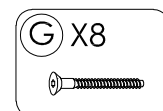

RICO 2 DRAWER 5 COMPARTMENT EXECUTIVE DESK

ITEM CODE: 2409-WHT/LSO

STEP 16

Attach sofa leg (S) to bottom panel (5) to frame using 30mm screw (C).

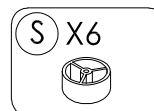
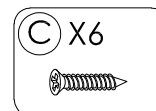
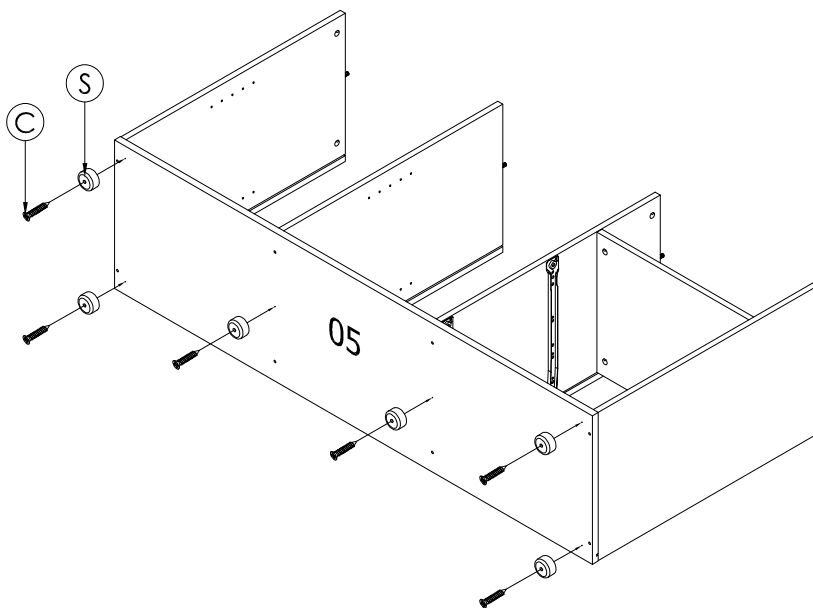
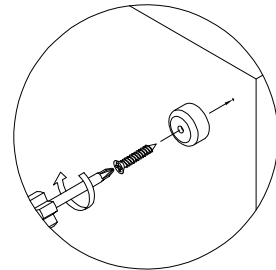

STEP 17

Slot panels (22 & 23) to frame.

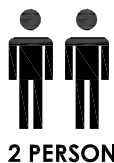
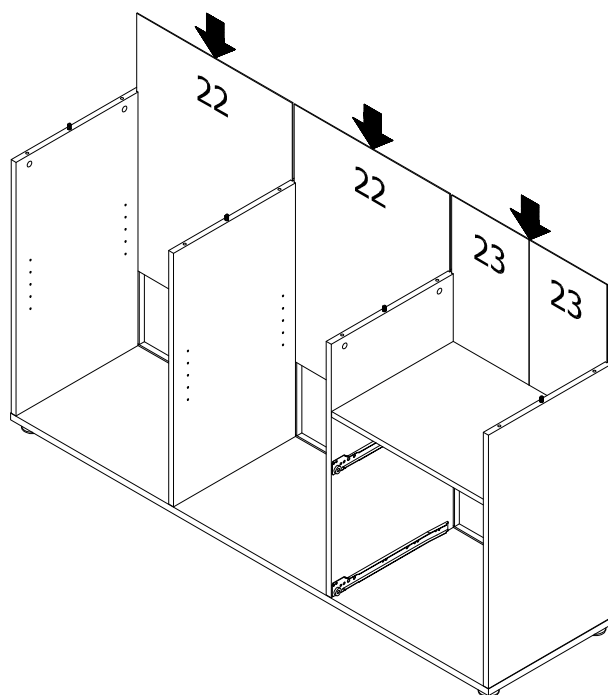

Note: Always use atleast 2 adults to stand the item upright

RICO 2 DRAWER 5 COMPARTMENT EXECUTIVE DESK

ITEM CODE: 2409-WHT/LSO

STEP 18

Using glue (X) attach top panel (4) to frame.
Fasten into place using cam lock (L) as shown.

Note: Please always ensure cam's are correctly locked to secure and support your item. Refer to Camlock guidelines at the beginning of this manual for further information.

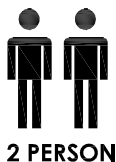
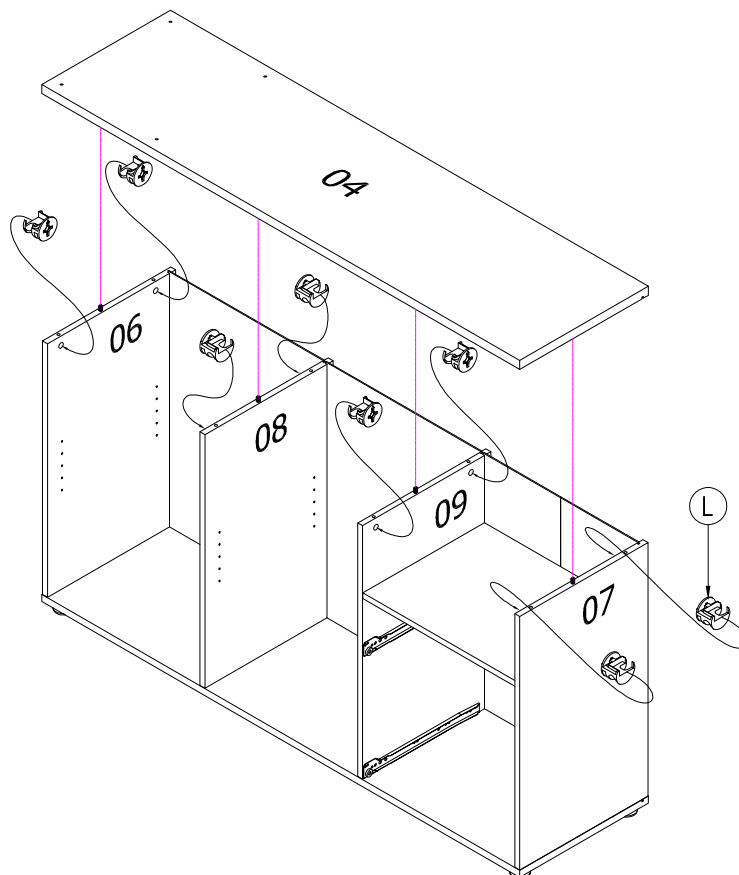
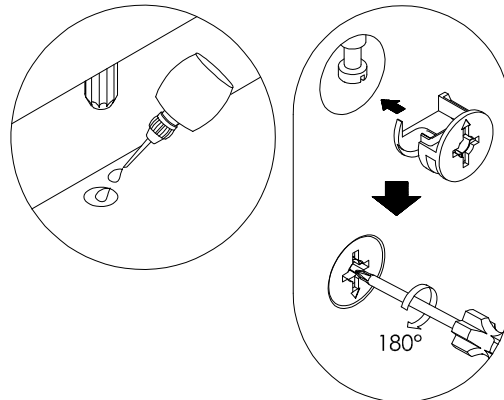

Note: Always use atleast 2 adults to carefully place the top panel onto the body frame

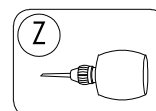
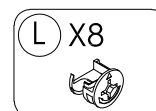

RICO 2 DRAWER 5 COMPARTMENT EXECUTIVE DESK

ITEM CODE: 2409-WHT/LSO

STEP 19

Attach the backply stoppers (W) to the back panel (22 & 23) using 15mm screw (B) as shown.

Tip: It is really important to attach the backply stoppers correctly as this will help with the overall structure and stability of the item.

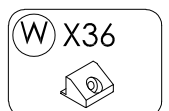
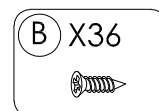
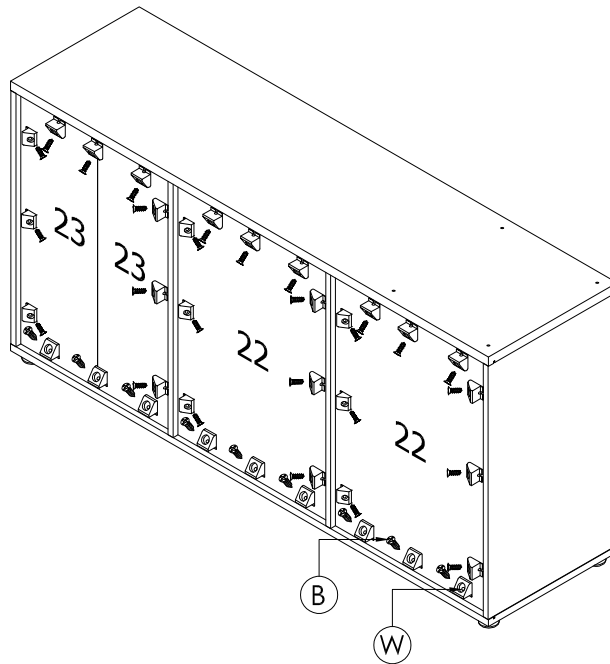
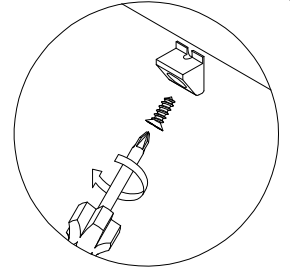

RICO 2 DRAWER 5 COMPARTMENT EXECUTIVE DESK

ITEM CODE: 2409-WHT/LSO

STEP 20

Using glue (X) attach side panel (2) to back panel (3), fasten into place using cam lock (L). Then plastic leg stud (T) to bottom as shown.

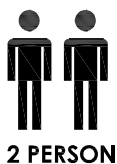
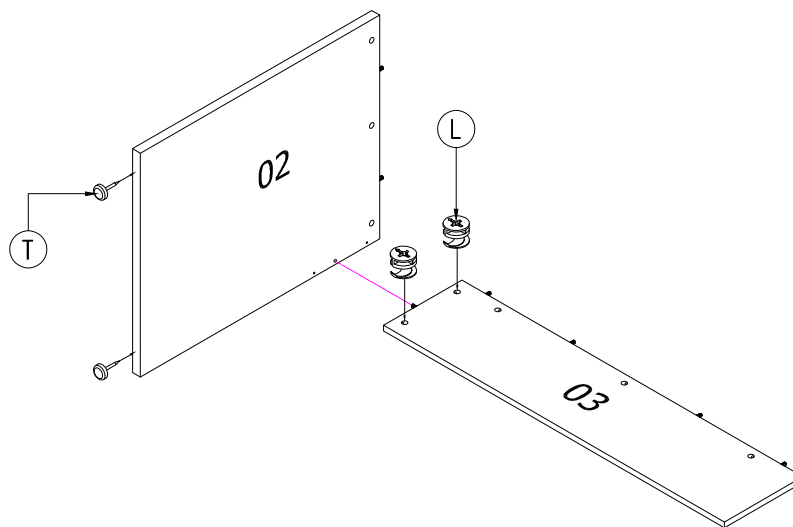
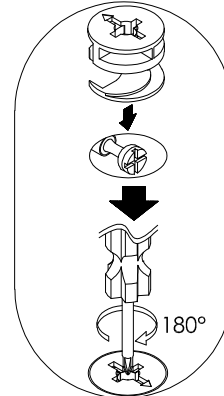
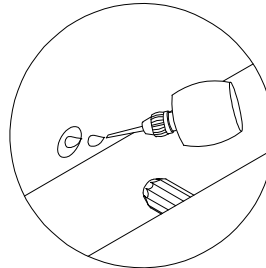
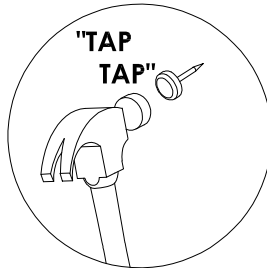

2 PERSON

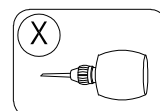
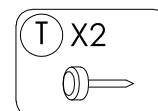
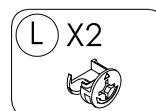

RICO 2 DRAWER 5 COMPARTMENT EXECUTIVE DESK

ITEM CODE: 2409-WHT/LSO

STEP 21

Using glue (X) attach top panel (1) to side panel (2) and back panel (3), fasten into place using cam lock (L) as shown.

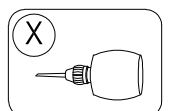
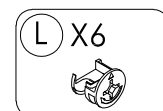
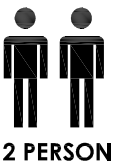
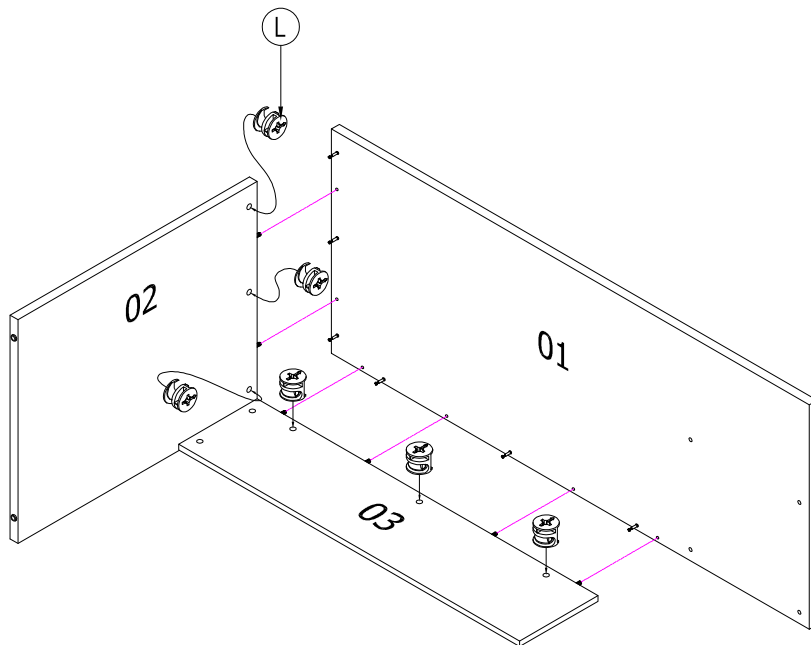
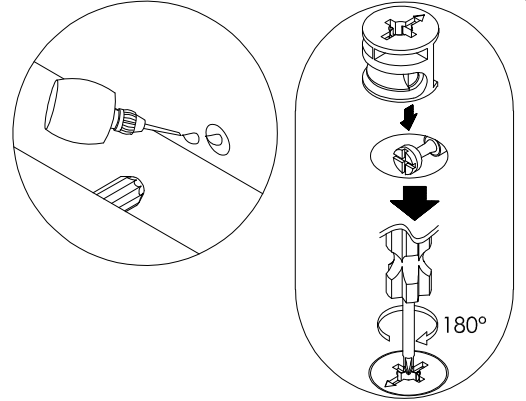

RICO 2 DRAWER 5 COMPARTMENT EXECUTIVE DESK

ITEM CODE: 2409-WHT/LSO

STEP 22

Attach table assembly (1 & 2) to body using 30mm screw (F) with allen key (V) as shown.

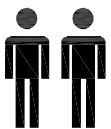
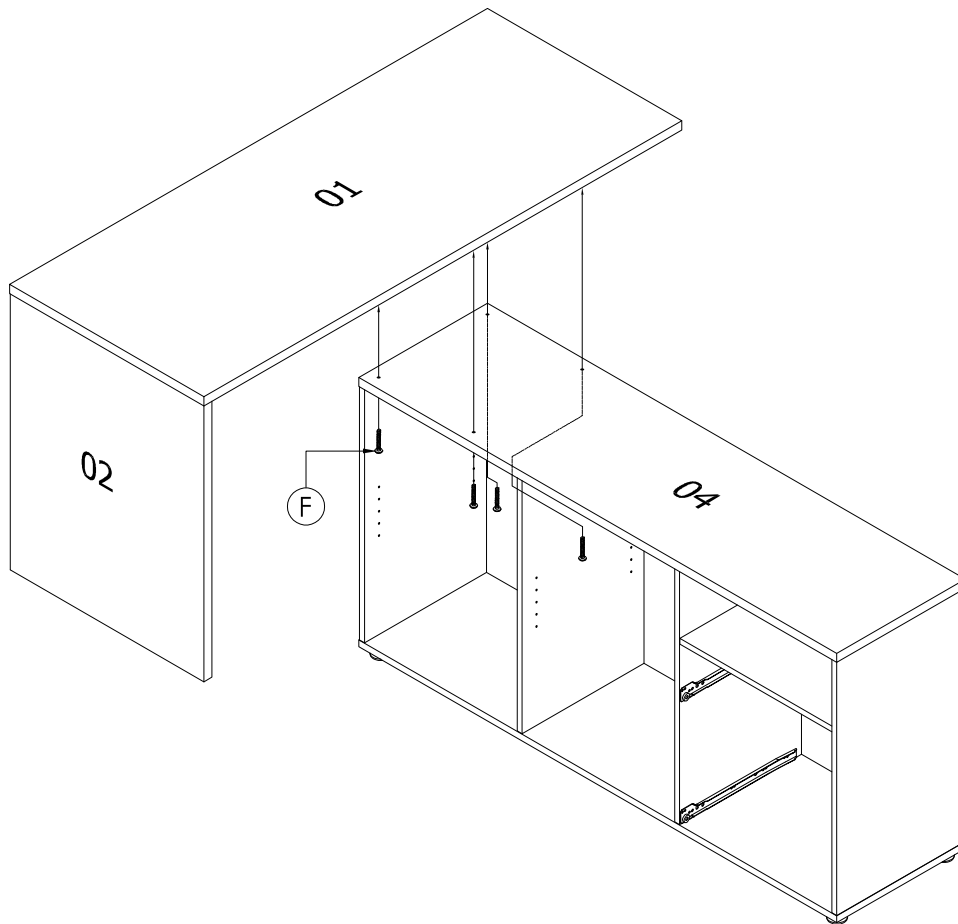
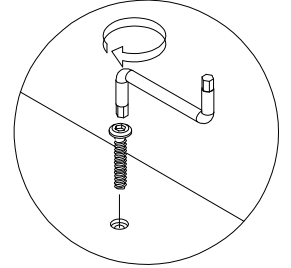

2 PERSON

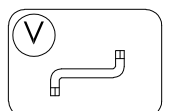
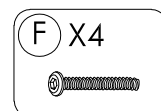

RICO 2 DRAWER 5 COMPARTMENT EXECUTIVE DESK

ITEM CODE: 2409-WHT/LSO

STEP 23

Insert the metal adjustable shelf stud (U) to panel (6 , 8 & 9), then slot the shelf panel (10) into the body as shown.

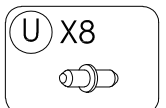
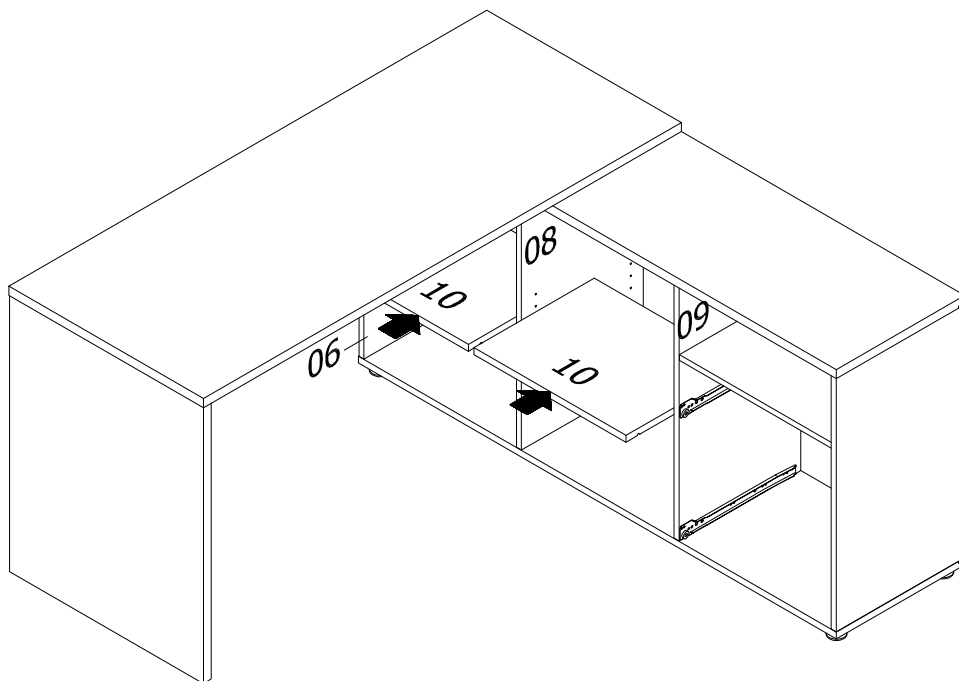
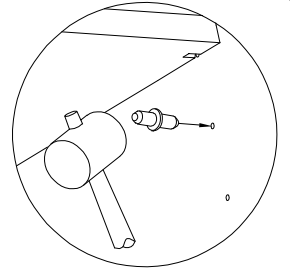

RICO 2 DRAWER 5 COMPARTMENT EXECUTIVE DESK

ITEM CODE: 2409-WHT/LSO

STEP 24

Affix the drawer to the body.

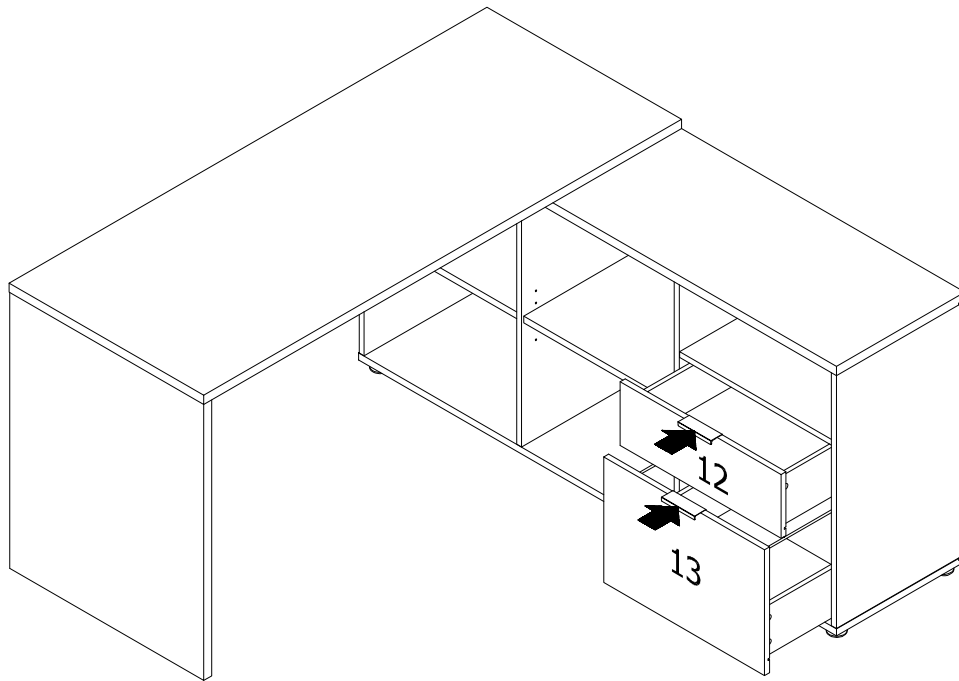



MEUBILAIR
DIRECT IMPORTS

Warranty Certificate

Congratulations! You have made an excellent choice of this quality product. Our commitment to quality also includes our service. Should you, contrary to expectations, experience defects due to manufacturing faults, **Meubilair Direct Imports** will provide you with a warranty against defects as follows:

Warranty

The product is guaranteed to be free from defects in workmanship and parts for a period of 12 months from the date of purchase. Defects that occur within this warranty period, under normal use and care, will be repaired, replaced or refunded at our discretion. The benefits conferred

by this warranty are in addition to all rights and remedies in respect of the product that the consumer has under the Competition and

Consumer Act 2010 and similar state and territory laws.

Our goods come with guarantees that cannot be excluded under the Australian Consumer Law. You are entitled to a replacement or refund for a major failure and for compensation for any other reasonably foreseeable loss or damage. You are also entitled to have the goods repaired or replaced if the goods fail to be of acceptable quality and the failure does not amount to a major failure.

Proof of Purchase

This warranty is valid for the original purchase and is not transferable. Please keep your purchase docket, tax invoice or receipt as the best proof of purchase, and as proof of date on which the purchase was made.

Normal Wear and Tear

This warranty does not cover normal wear and tear to the products or parts.

Exclusions

This warranty does not cover:

- Any defects caused by an accident, misuse, abuse, improper installation or operation, lack of reasonable care, unauthorized modification, loss of parts, tampering or attempted repair by a person not authorized by the distributor.
- Any product that has not been installed, operated or maintained in accordance with the manufacturers' operating instructions provided with the product.
- Any product that has been used for purposes other than domestic use.
- Any damage caused by improper power input or improper cable connection.

MEUBILAIR DIRECT IMPORTS PTY LTD

Customer Service

Email: cs@meubilair.com.au

Address: Unit 4, 16 Hickeys Lane, Penrith, NSW, 2750

Opening Hours 9:00 am - 4:00pm (Mon-Fri)

When making a return, please ensure the product is properly packaged, so as to ensure that no damage occurs to the product during transit.

Please provide the original or a copy of the proof of purchase. Also please make sure you have included an explanation of the problem.

Please note that the costs of making a warranty claim, including any return postage, will be covered by the supplier identified above.

Please note upon receiving your warranty claim, the supplier will send, via the post or email, a repair and refurbished goods or parts notice.

Please provide your email address and advise the supplier, if you wish to obtain a repair and refurbished goods or parts notice via email.

AFTER SALES SUPPORT

EMAIL : cs@meubilair.com.au

Product code: 2490-WHT/LSO

10/2022





MEUBILAIR
DIRECT IMPORTS

Warranty Certificate

PRODUCT NAME **RICO 2 DRAWER 5 COMPARTMENT EXECUTIVE DESK**

BRAND NAME

PRODUCT CODE **2490-WHT/LSO**

NAME

ADDRESS

EMAIL

DAYTIME TEL NO

DATE OF PURCHASE

SERIAL NUMBER

We recommend that you attach a photocopy of your receipt, showing the date of purchase, to this Warranty certificate and **keep for your reference**.

In the event of a product fault, please email the Customer Service team. Please ensure that you include the product details (as shown on the card) at hand so that we are able to respond as quickly and efficiently as possible.

MEUBILAIR DIRECT IMPORTS PTY LTD

Customer Service

Email: cs@meubilair.com.au

Address: Unit 4, 16 Hickeys Lane, Penrith, NSW, 2750

Opening Hours 9:00 am - 4:00pm (Mon-Fri)

Phone Number: +61 2 47015363

AFTER SALES SUPPORT

Product code: 2490-WHT/LSO

10/2022

