

TRIBECCA 5 DRAWER CHEST

ITEM CODE : 5096

1.5HRS

APPROXIMATE ASSEMBLY TIME



**2 PERSON
ASSEMBLY**

**FLOOR AREA
2.0M X 2.0M**



REQUIRED ASSEMBLY SPACE

REQUIRED ASSEMBLY TOOLS

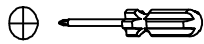

POZI SCREWDRIVER

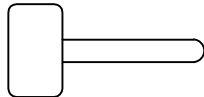

HAMMER

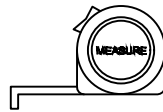

MEASURING TAPE



DRILL

ASSEMBLED DIMENSIONS

5096-WHT / 5096-LSO

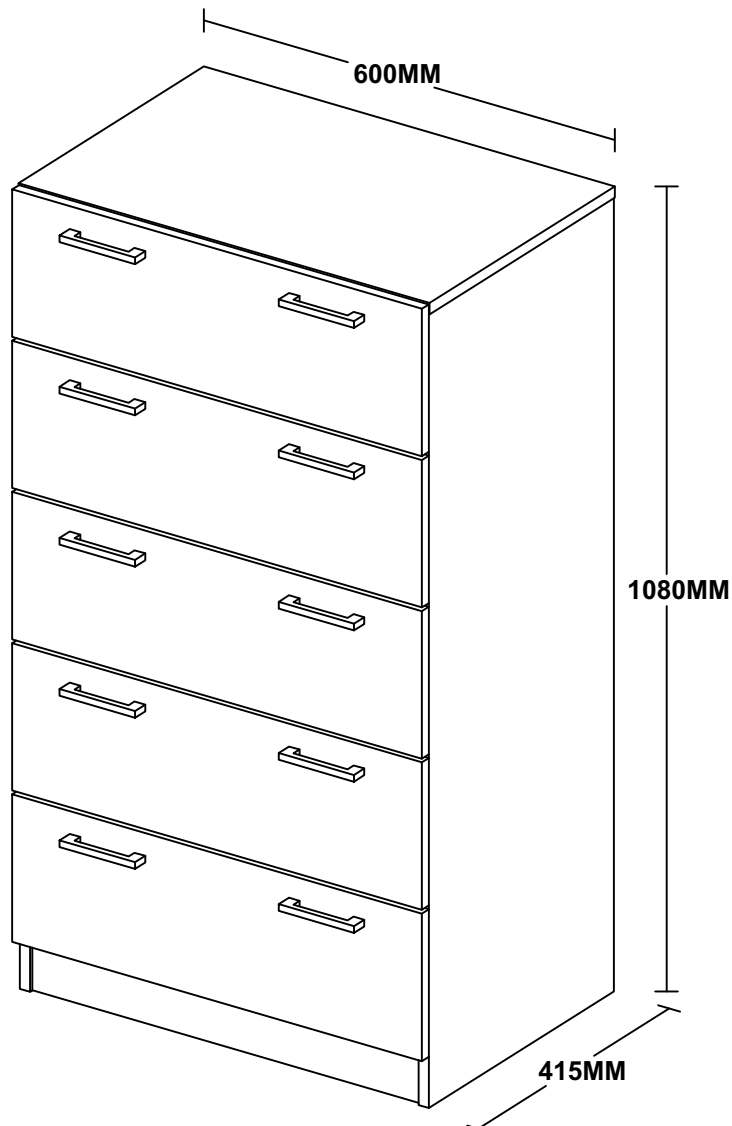

TRIBECCA 5 DRAWER CHEST

ITEM CODE : 5096

Important :

Please read these instructions carefully before use and keep for future reference.

- This product is intended for domestic use only and is not designed for commercial use.
- DO NOT assemble / use this item if any components are missing or damaged. Please contact the retailer straight away.
- DO NOT attempt to modify your item as this will void your warranty. Please call the retailer for required parts.
- Assembly to be carried out by a competent adult only.
- During assembly children should be kept away from the product due to possible risk of injury.

Please refer to separate Warranty Certificate for full warranty details and information.

Tips before you start :

- Please check that all parts are present before you start the assembly of your furniture. Please do not start to build your item if any parts are damaged as this may void your warranty. Please contact the retailer immediately so they can advise what you should do.
- For ease and speed of assembly, we recommend that before you commence each step of the assembly, that you identify all the parts required for that step.

TRIBECCA 5 DRAWER CHEST

ITEM CODE : 5096

Assembly Tips:

1. For larger items, please ensure that you have sufficient space and people (as indicated on page 1) to assemble your product safely.
2. We recommend that, where possible, all items are assembled near to the area in which they will be placed in use, to avoid moving the product unnecessarily once assembled.
3. For the protection of your furniture, we recommend that the product is placed on a protected surface during assembly to prevent any damage.
4. During assembly please take care not to over-tighten, any fittings, as this may damage the product.
5. Always place the product on a flat, steady and stable surface.
6. Do not stand on the product. Do not use the product as a stepladder.
7. This product is intended for indoor, household use only as it is a non industrial product.
8. Use of power tools is NOT recommended for assembling this product as over-tightening may occur and damage the product.
9. Due to the laminated finish of this item and the materials used to construct it, when first opening the carton and assembling a slight smell may be noticeable. This will dissipate over a short period of time. Please contact the retailer you purchased this item from if you have any concerns.
10. Please use caution and care when lifting the product to avoid personal injury and / or damage.

Care and Maintenance of your Furniture

- Please periodically check all fittings and re-tighten as necessary.
- To clean your item, please use a damp cloth and wipe clean. Never use harsh chemicals or strong detergents as this could damage the finish of your product.
- Never allow any kind of liquid to remain on your furniture. Absorption can cause wood to warp or finishes to de-laminate.
- Please do not place hot / cold items (e.g. hot drinks) directly on to the surface.
- Do not pull or drag your item. Ensure it is evenly supported and lifted while moving it.
- Avoid placing sharp objects on the surface as this may scratch the surface. It is recommended to use trivets or coasters under flowerpots, vases, cups etc to avoid damage to your item.

TRIBECCA 5 DRAWER CHEST

ITEM CODE : 5096

Tips before you start:

QUICKFIT

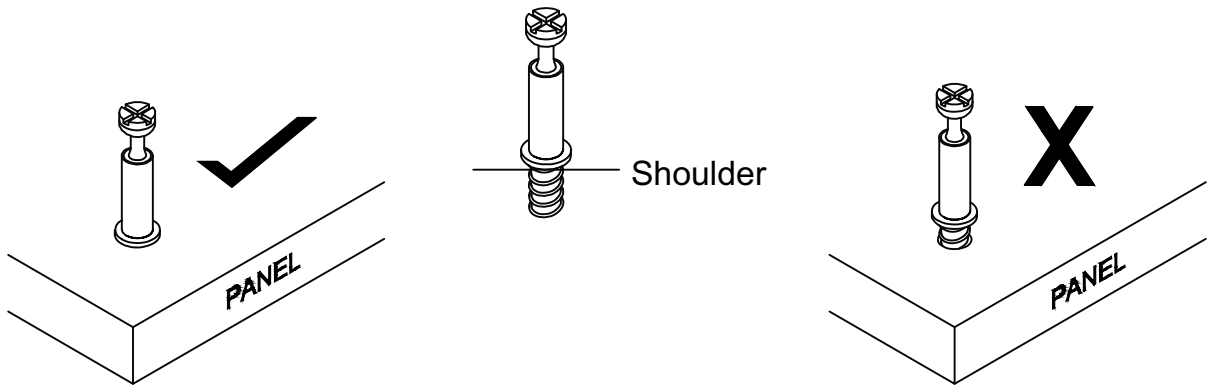

Tighten quickfit until shoulder is flush with panel. do not overtighten or unde tighten.

CAM LOCK

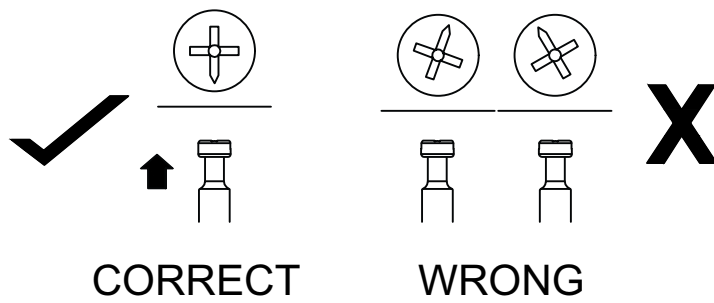

When fitting cam lock , ensure starting position is correct before you insert connecting quickfit.

Quickfit head should be in the center of the cam lock when the two panels are joined.

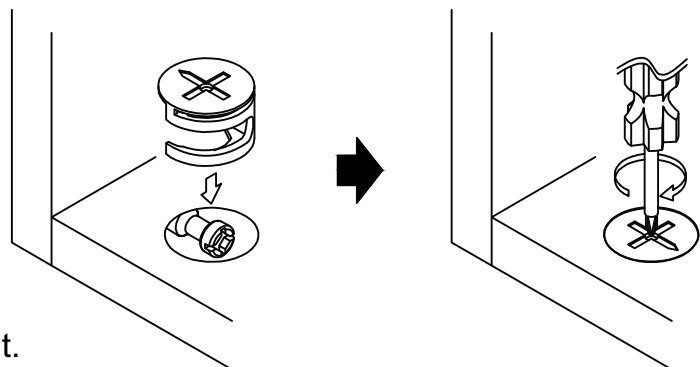

Cam lock should be inserted before quickfit.

Turn camlock clockwise to tighten.

TRIBECCA 5 DRAWER CHEST

ITEM CODE : 5096

PART LIST:

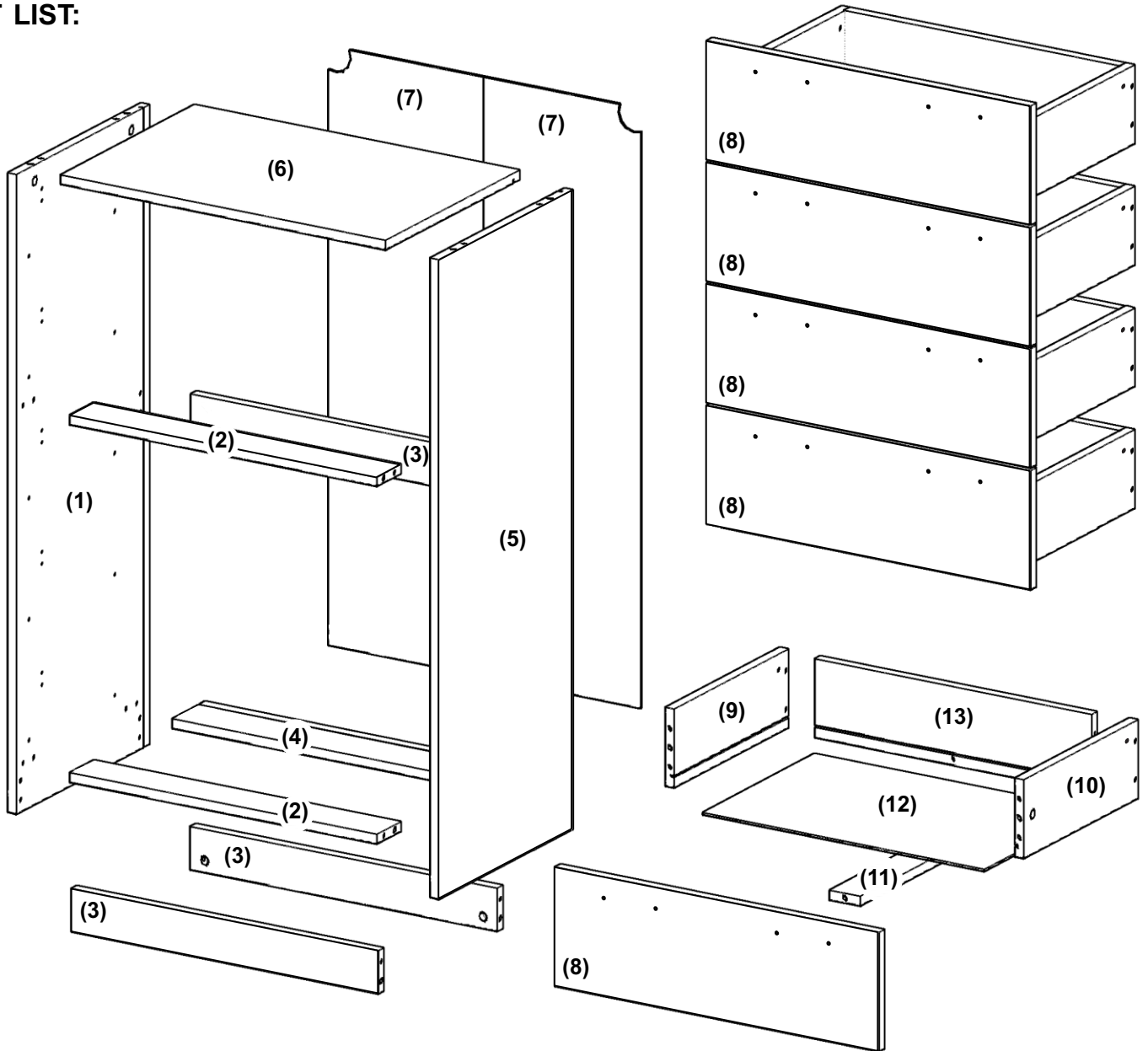

NO.	PART NAME	QTY
1	SIDE PANEL (LEFT)	1
2	SUPPORT RAIL (FRONT)	2
3	SUPPORT RAIL	3
4	SUPPORT RAIL (BACK)	1
5	SIDE PANEL (RIGHT)	1
6	TOP PANEL	1
7	BACK PANEL	2

NO.	PART NAME	QTY
8	DRAWER FRONT	5
9	DRAWER SIDE (LEFT)	5
10	DRAWER SIDE (RIGHT)	5
11	DRAWER SUPPORT	5
12	DRAWER BOTTOM	5
13	DRAWER BACK	5

TRIBECCA 5 DRAWER CHEST

ITEM CODE : 5096

HARDWARE LIST

A x30



M3.5 x 8mm UR SCREW

B x50



C/B SCREW M3.5 x 12mm

C x2

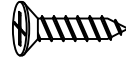

C/B SCREW M3.5 x 16mm

D x10



C/B SCREW M3.5 x 20mm

E x20



M3.5 x 38mm SCREW

F x46

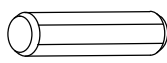

DOWEL Ø6 x 25mm

G x10 SET

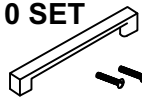

96mm Aluminium Handle(1PC)
with Screw M4 x 20MM (2 PCS)

H x10

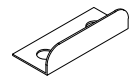

DRAWER LOCK SUPPORT

I x36



CAM NUT

J x36

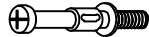

CAM BOLT

K x4



PLASTIC LEG STUD

L x10



BACK PANEL CONNECTOR

M1 x5

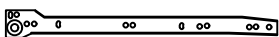

METAL DRAWER SLIDE
(350MM)

M2 x5

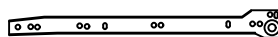

METAL DRAWER SLIDE
(350MM)

N1 x5

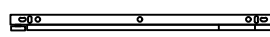

METAL DRAWER SLIDE
(350MM)

N2 x5

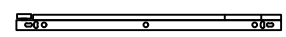

METAL DRAWER SLIDE
(350MM)

O x2



L-BRACKET

Tips before you start :

- Please check that all parts are present before you start the assembly of your furniture. Please do not start to build your item if any parts are damaged as this may void your warranty. Please contact the retailer immediately so they can advise what you should do.
- For ease and speed of assembly, we recommend that before you commence each step of the assembly, that you identify all the parts required for that step.

TRIBECCA 5 DRAWER CHEST

ITEM CODE : 5096

STEP 1

Insert dowel (F) into pieces (1,2,3,4,5,9,10) as shown.

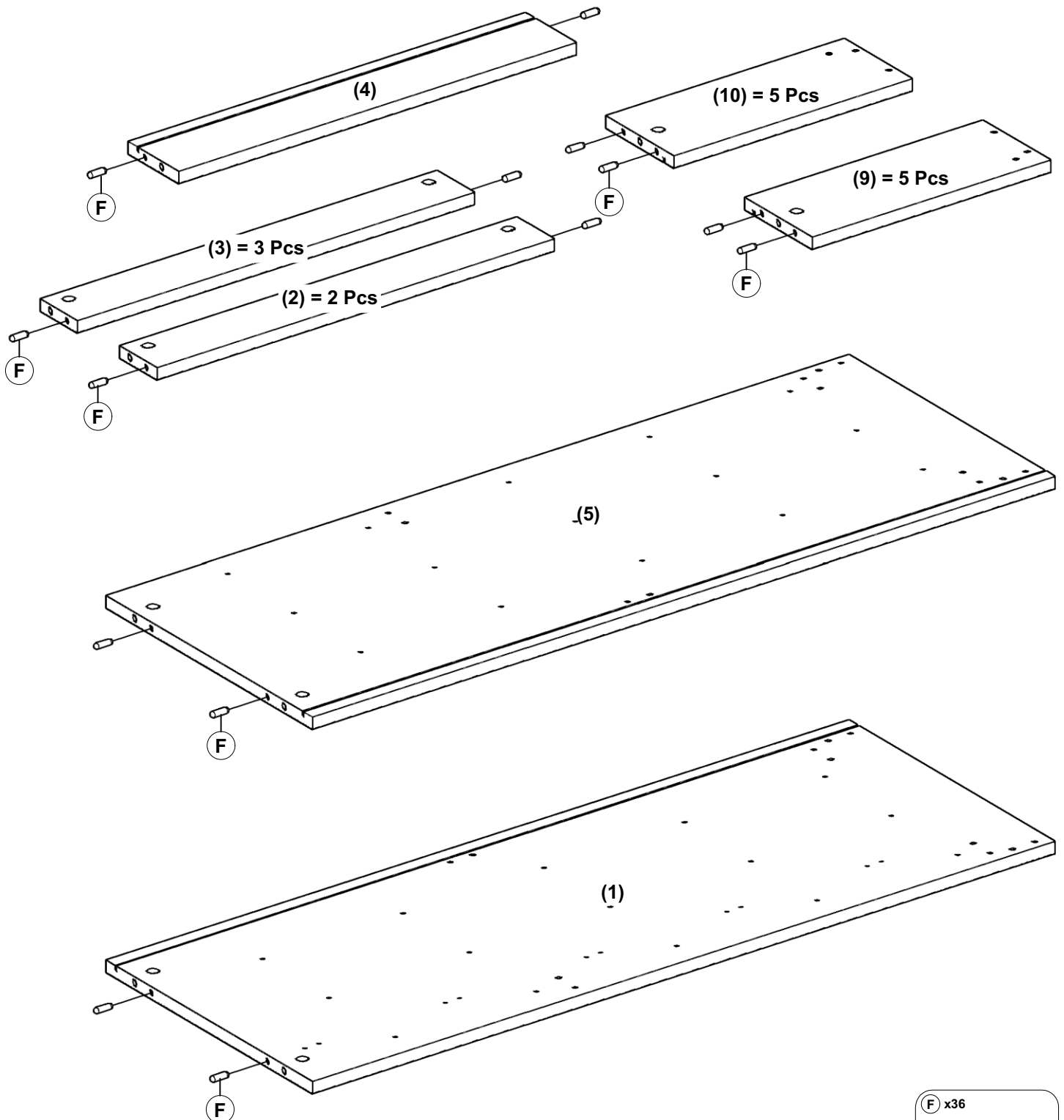

TRIBECCA 5 DRAWER CHEST

ITEM CODE : 5096

STEP 2

Take all panels (1,5,6,8,13) using a phillips head screw driver CAM BOLT (J) as shown.

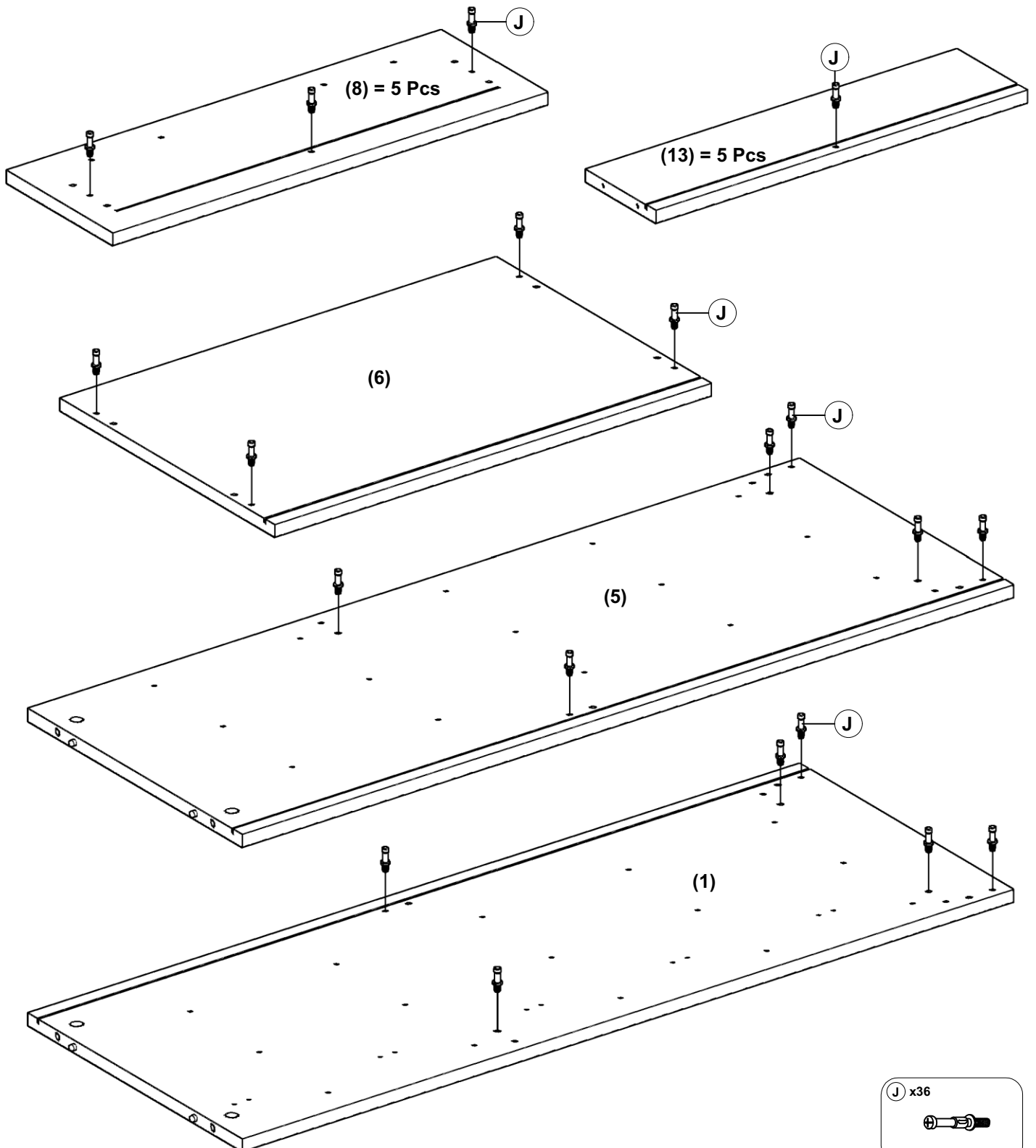

TRIBECCA 5 DRAWER CHEST

ITEM CODE : 5096

STEP 4

Take both side panels (1,5) attach drawer slide (M1 & M2) using screw (A).

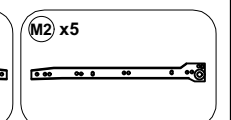
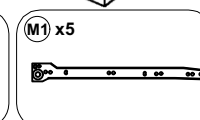
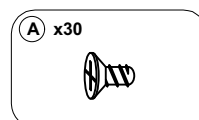
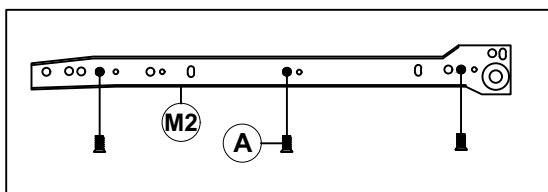
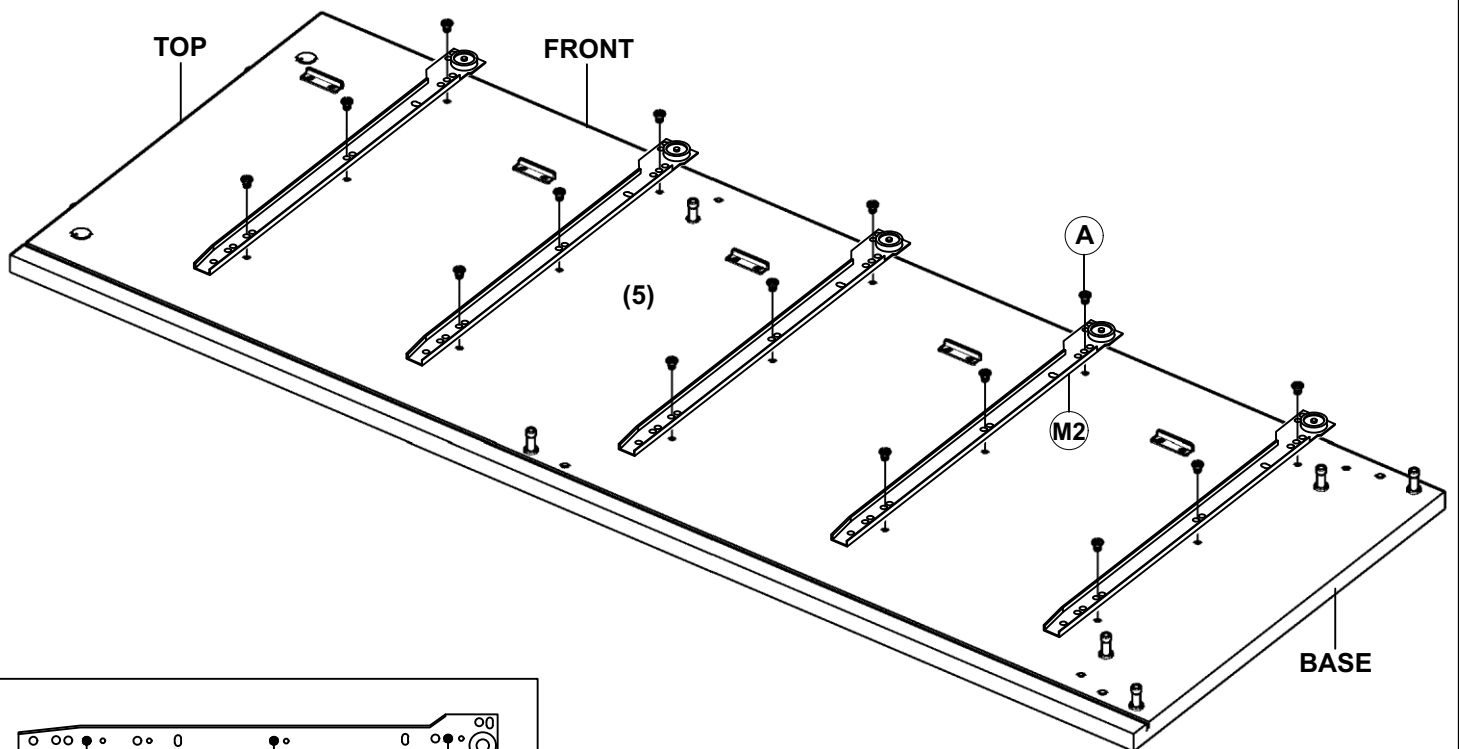
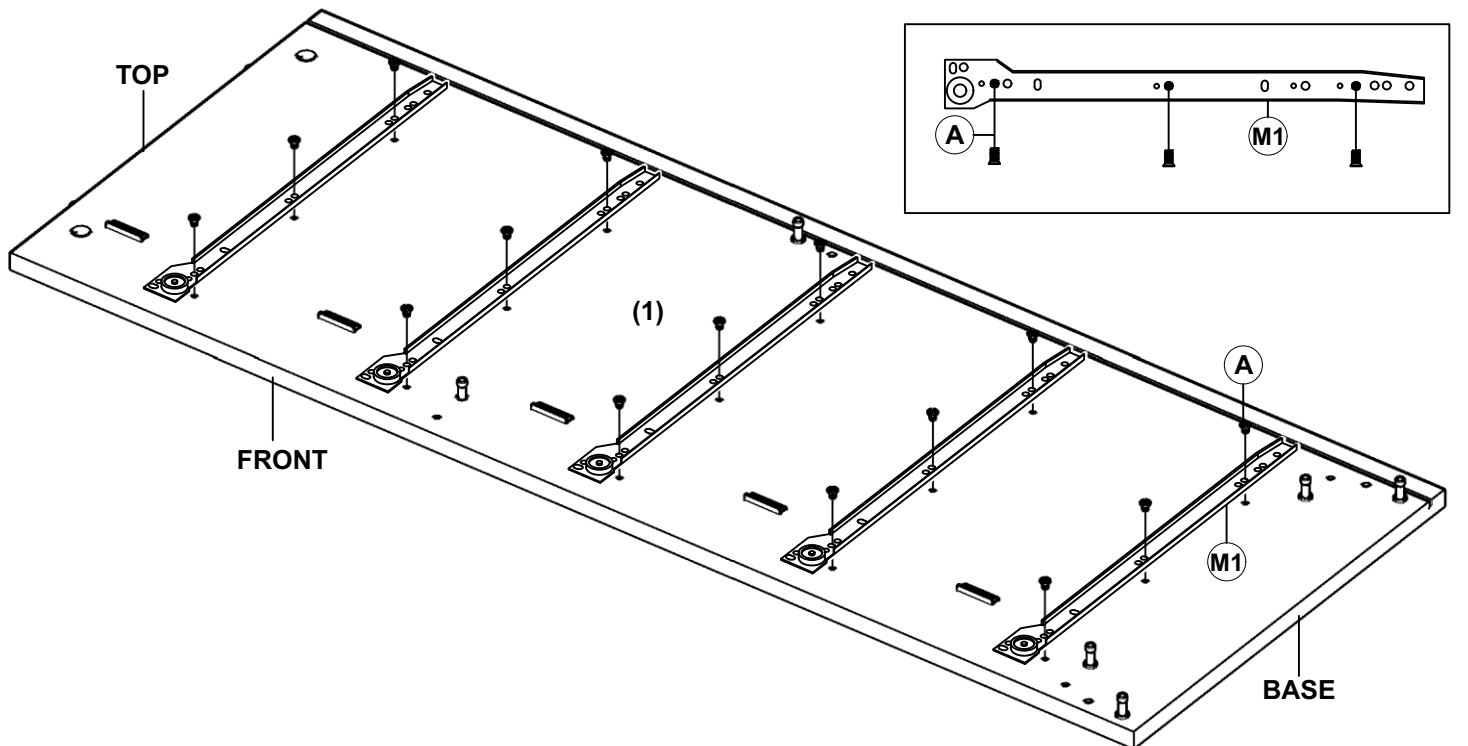

TRIBECCA 5 DRAWER CHEST

ITEM CODE : 5096

STEP 5

Secure the drawer sides (9 and 10) to the drawer front (8) by fasten into place using CAM BOLT (J) as shown in the picture, slide the drawer bottom (12) to the drawer front panel (8), put the cam nut (I) into the designated hole and tighten 180°.

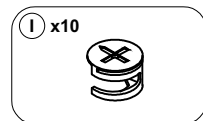
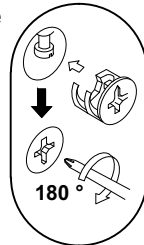
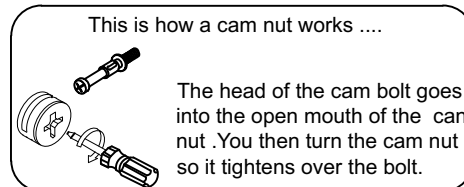
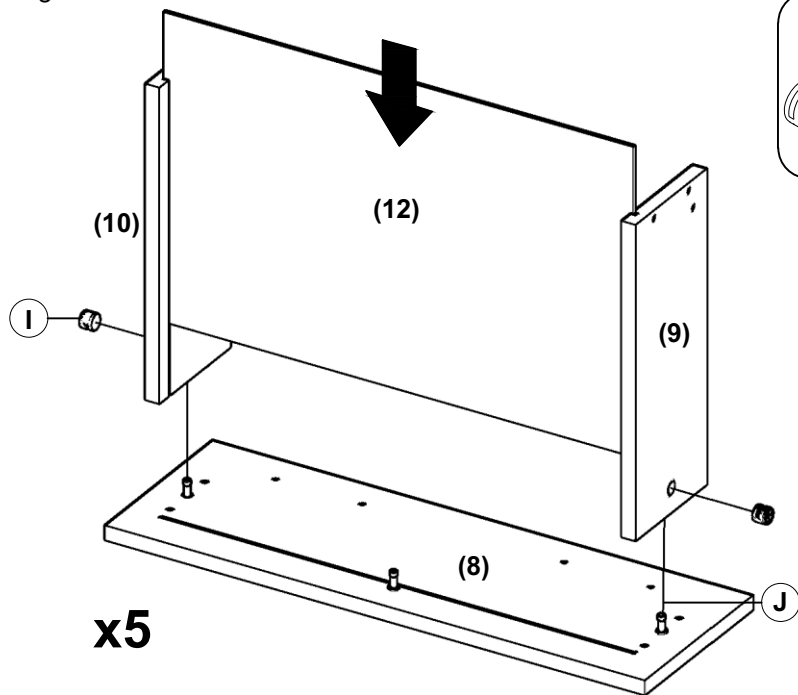

STEP 6

Install the panel (11) to the drawer front panel (8), put the cam nut (I) into the designated hole and tighten 180°.

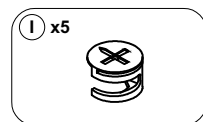
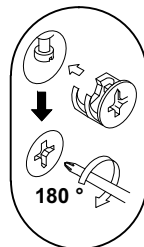
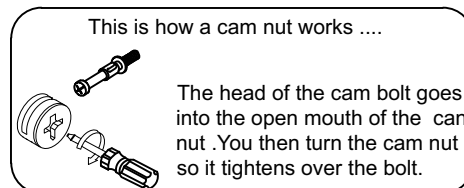
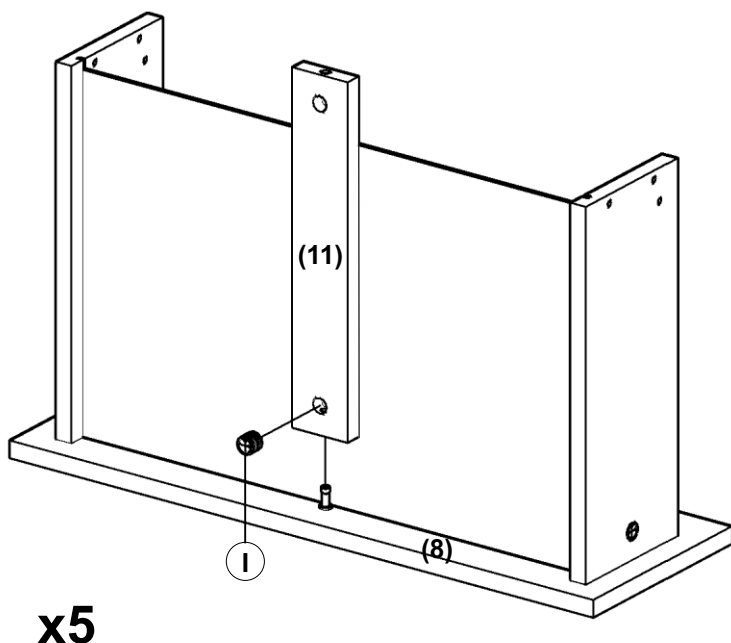

TRIBECCA 5 DRAWER CHEST

ITEM CODE : 5096

STEP 7

Install the drawer back panel (13) to the panel (11). Fix the cam bolt (J) and put the cam nut (I) into the designated hole at panel (11) and tighten 180°.

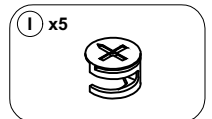
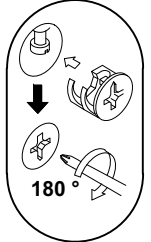
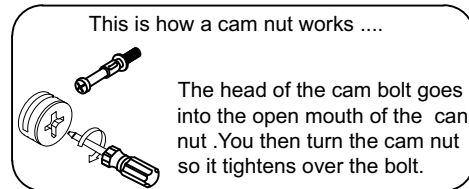
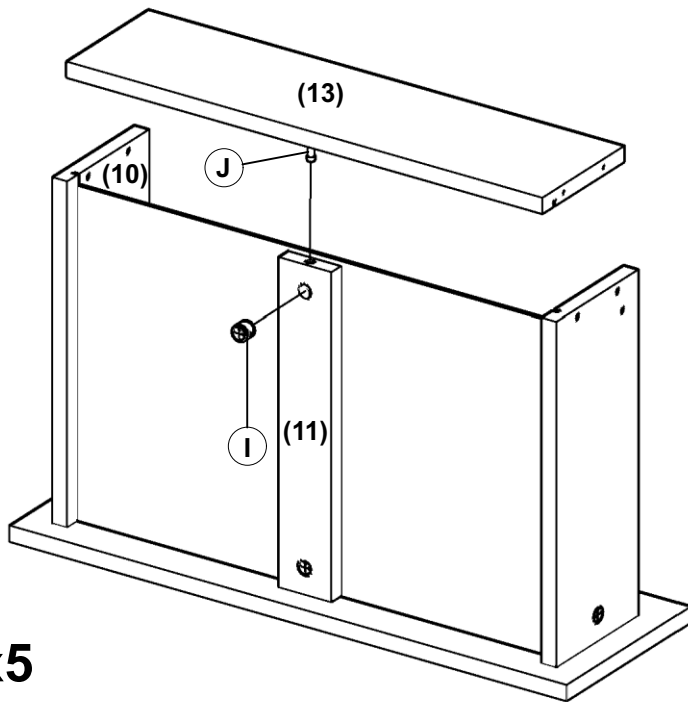

STEP 8

Secure the drawer sides (9 and 10) to the drawer back (13) using screws (E) as shown.

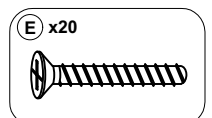
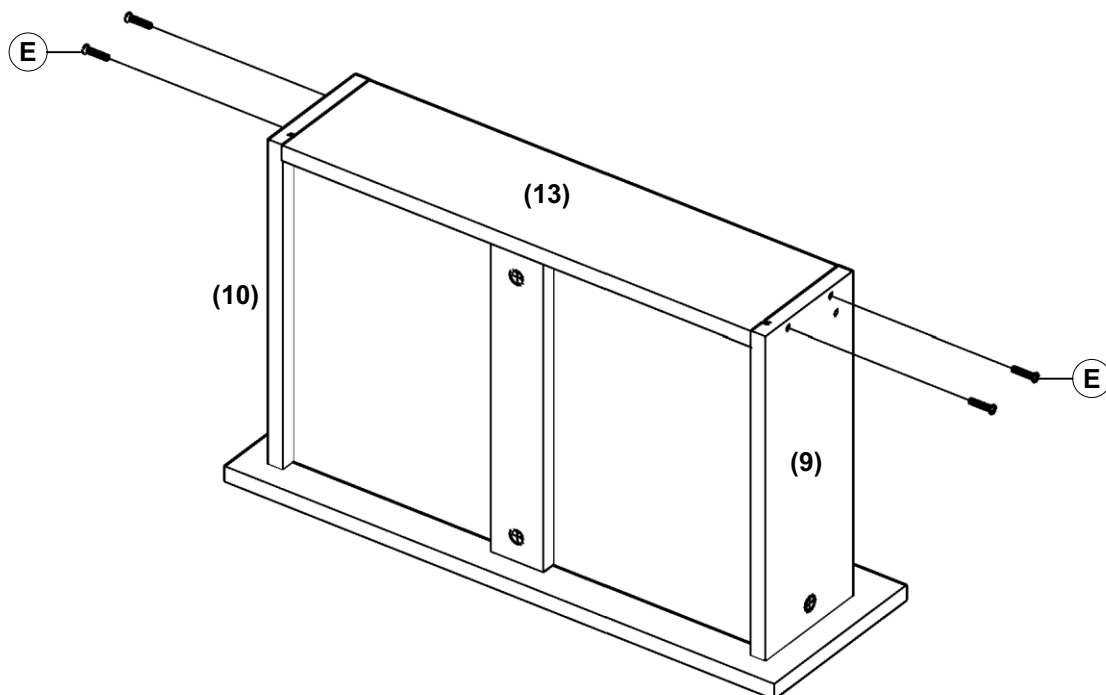

TRIBECCA 5 DRAWER CHEST

ITEM CODE : 5096

STEP 9

Affix the handle (G) to the drawer (8) with the 25mm screw.

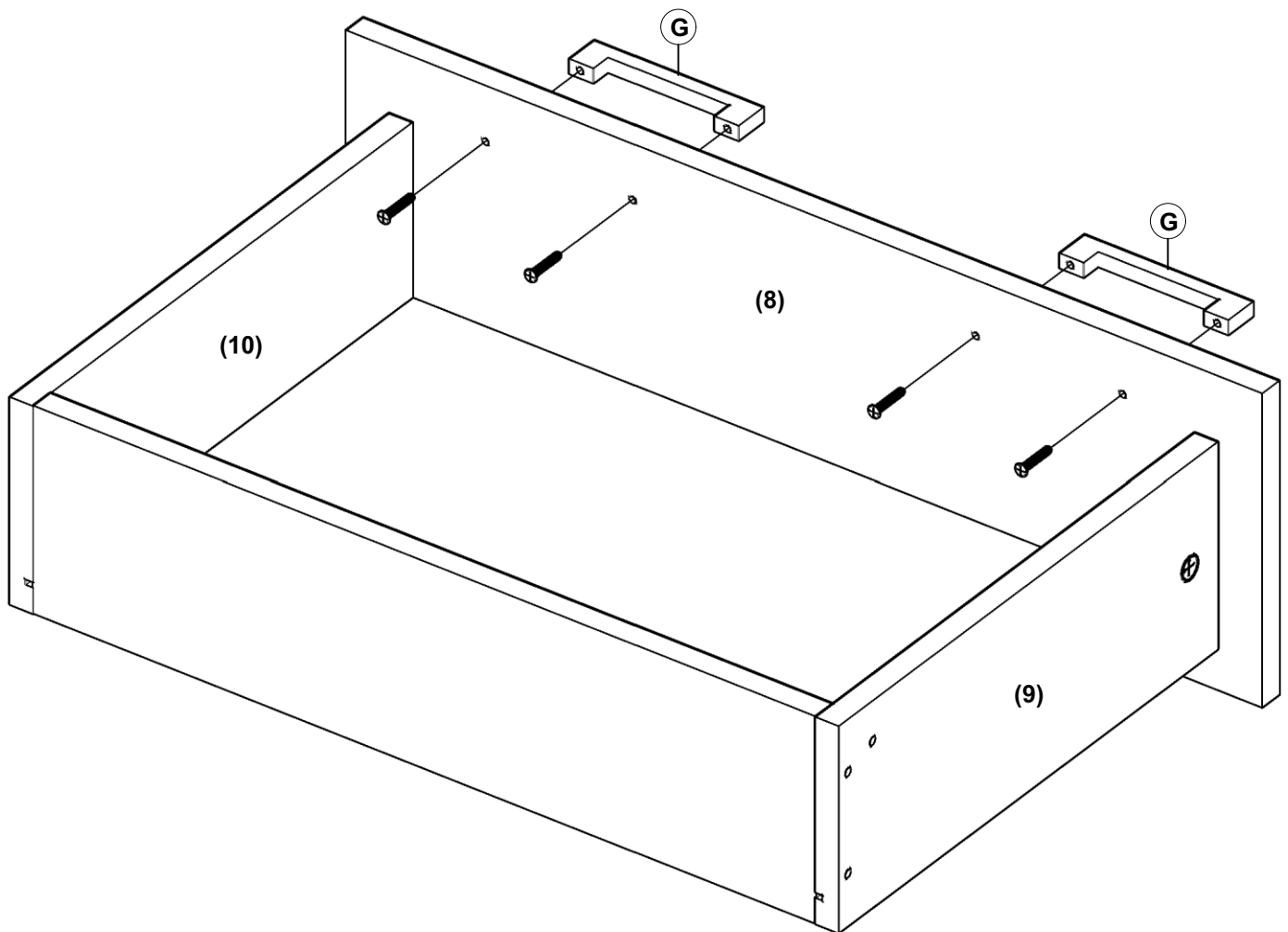

x5

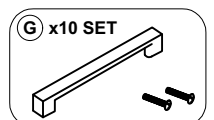

TRIBECCA 5 DRAWER CHEST

ITEM CODE : 5096

STEP 9

Attach the drawer slide inserts (N1 & N2) to the base of the drawer side (9 & 10) with the screw (B) as shown.

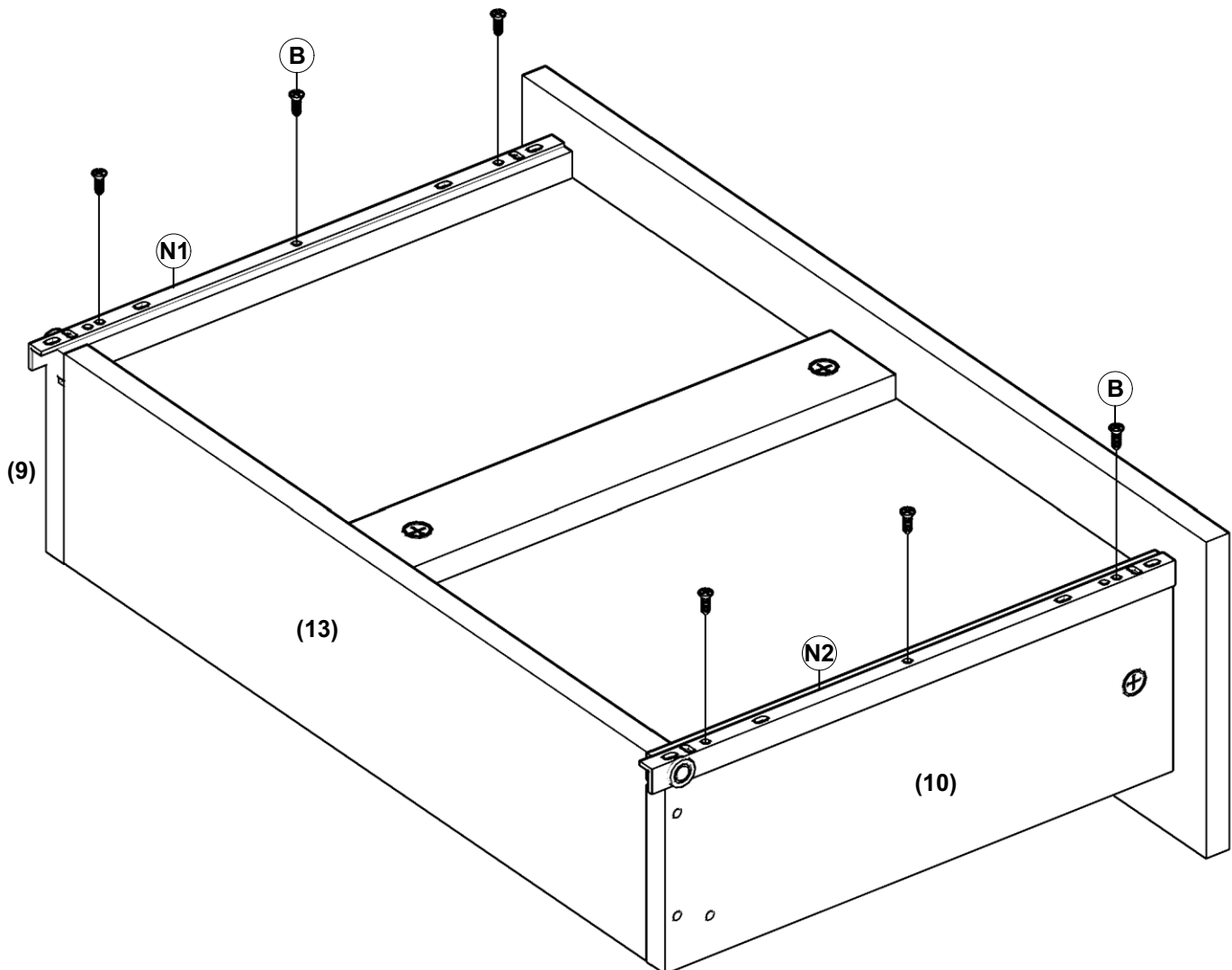

x5

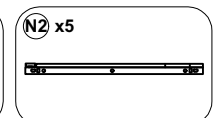
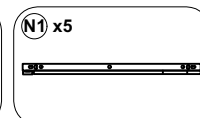
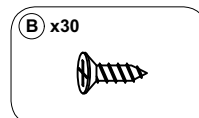

TRIBECCA 5 DRAWER CHEST

ITEM CODE : 5096

STEP 11

Attach panels (1 & 5) to frame with cam lock (I) on panels (2,3,4) as shown.
Turn cam lock using screw driver until they tighten into place.

Tack the plastic leg stud to side panel (1 & 5) as shown.

Note: Carefully check your cam lock are securely fastened to ensure correct stability of your item.

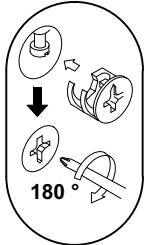

This is how a cam nut works

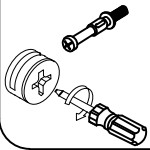

The head of the cam bolt goes into the open mouth of the cam nut. You then turn the cam nut so it tightens over the bolt.

Tips: Make sure the cams are all facing the same way as the diagram so they won't be visible from the front once it is built.

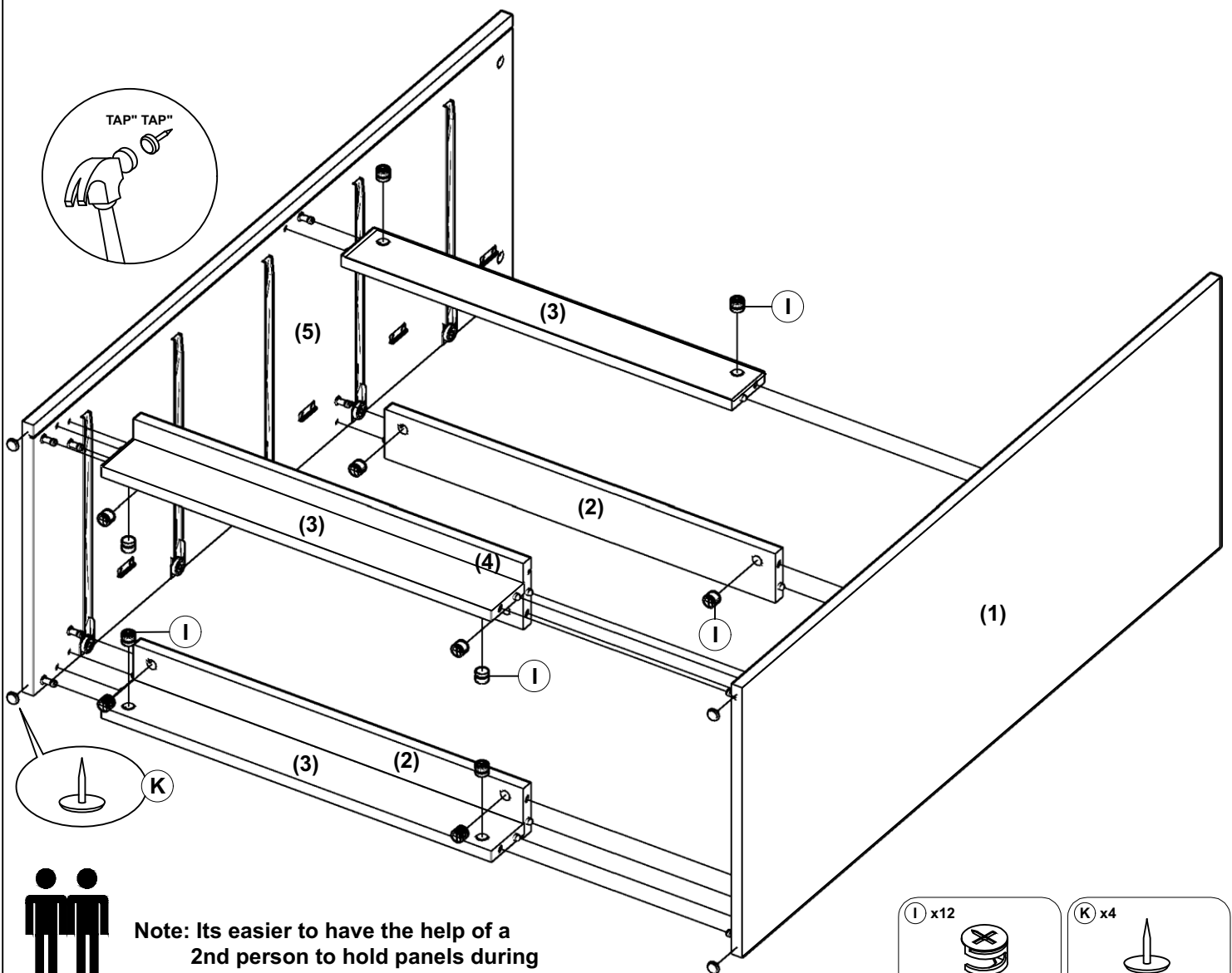

Note: Its easier to have the help of a 2nd person to hold panels during this step and avoid damage to your item.

TRIBECCA 5 DRAWER CHEST

ITEM CODE : 5096

STEP 11

Slot panels (7) to frame.

TIP : Before installing the backing board please carefully check to make sure all the cam bolt are locked tightly into position.

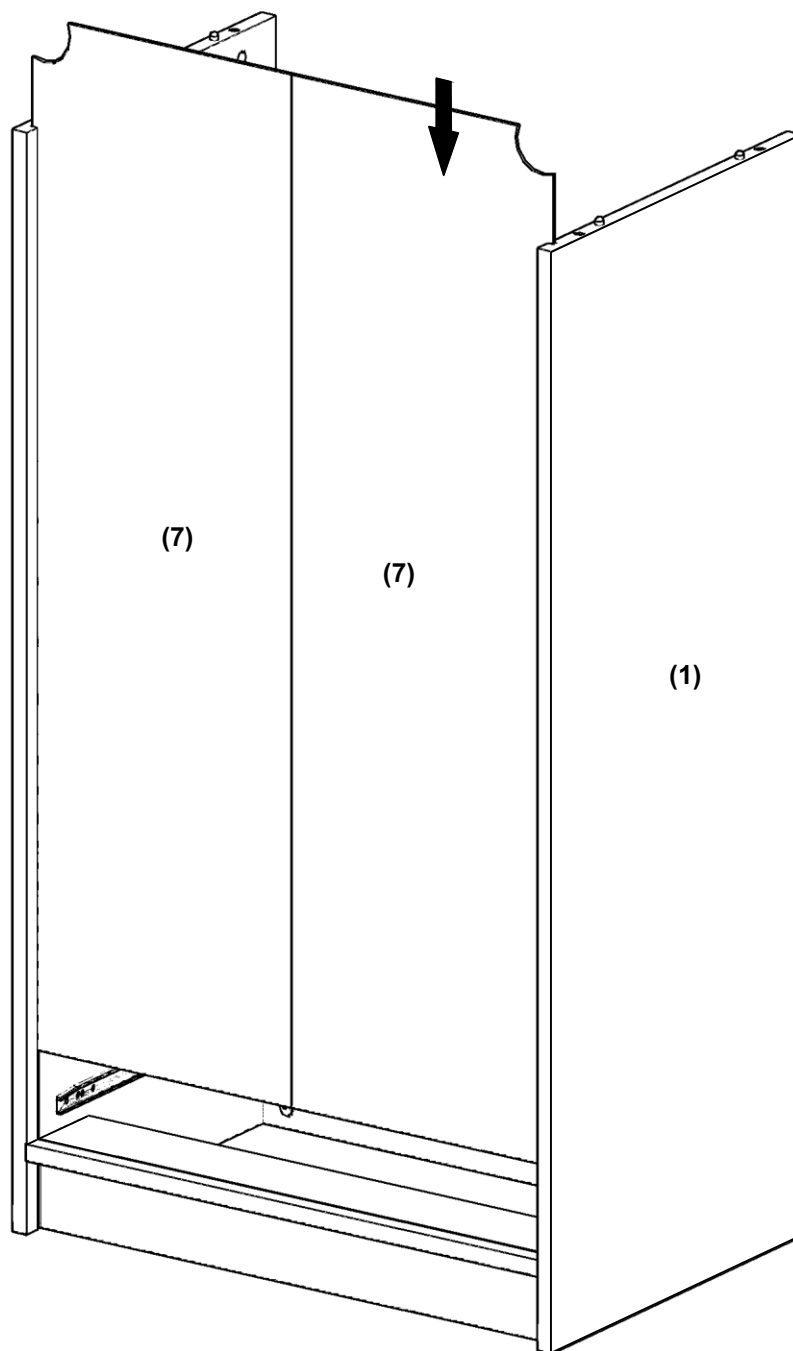

Make sure the wall strap holes are facing towards the top as shown.



2 PERSON

Note: Always ensure 2 adults help to stand the item upright

TRIBECCA 5 DRAWER CHEST

ITEM CODE : 5096

STEP 12

Stand the cabinet up and install the top panel (6) to the frame. Secure in place using cam lock (1) as shown.

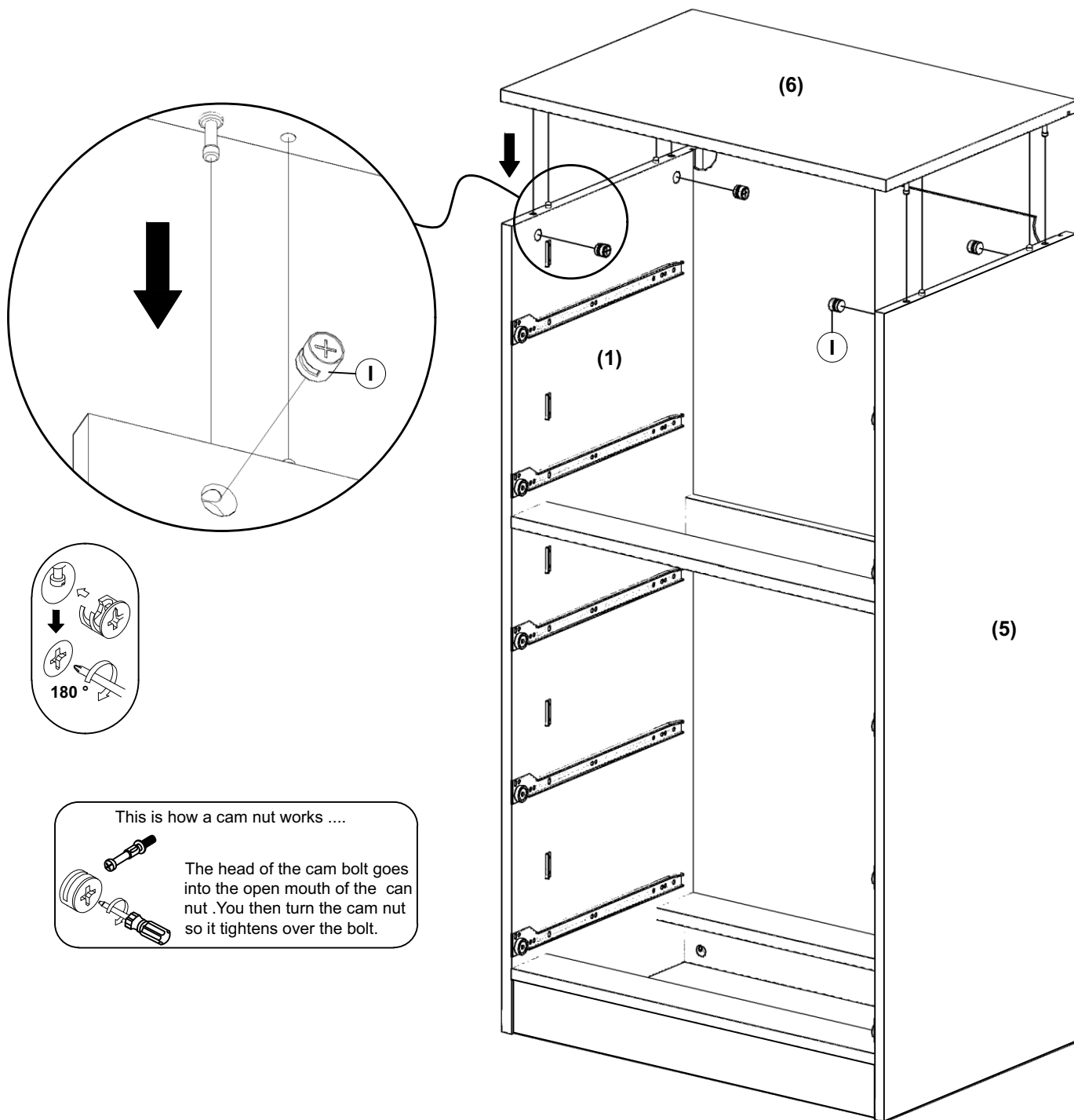

This is how a cam nut works

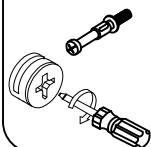

The head of the cam bolt goes into the open mouth of the cam nut. You then turn the cam nut so it tightens over the bolt.

(1) x4



TRIBECCA 5 DRAWER CHEST

ITEM CODE : 5096

STEP 13

Insert all drawers into the cavity and make sure you follow the safety instructions below to attach the drawer stoppers.

IMPORTANT SAFETY INSTRUCTIONS:

To prevent the drawers from accidentally being pulled out during use you must push the dowel (F) through the provided hole on the side of the drawer. To do this ensure the hole for the dowel is still positioned behind the previously installed brackets on the left hand side panel. When correctly placed your drawer will function normally.

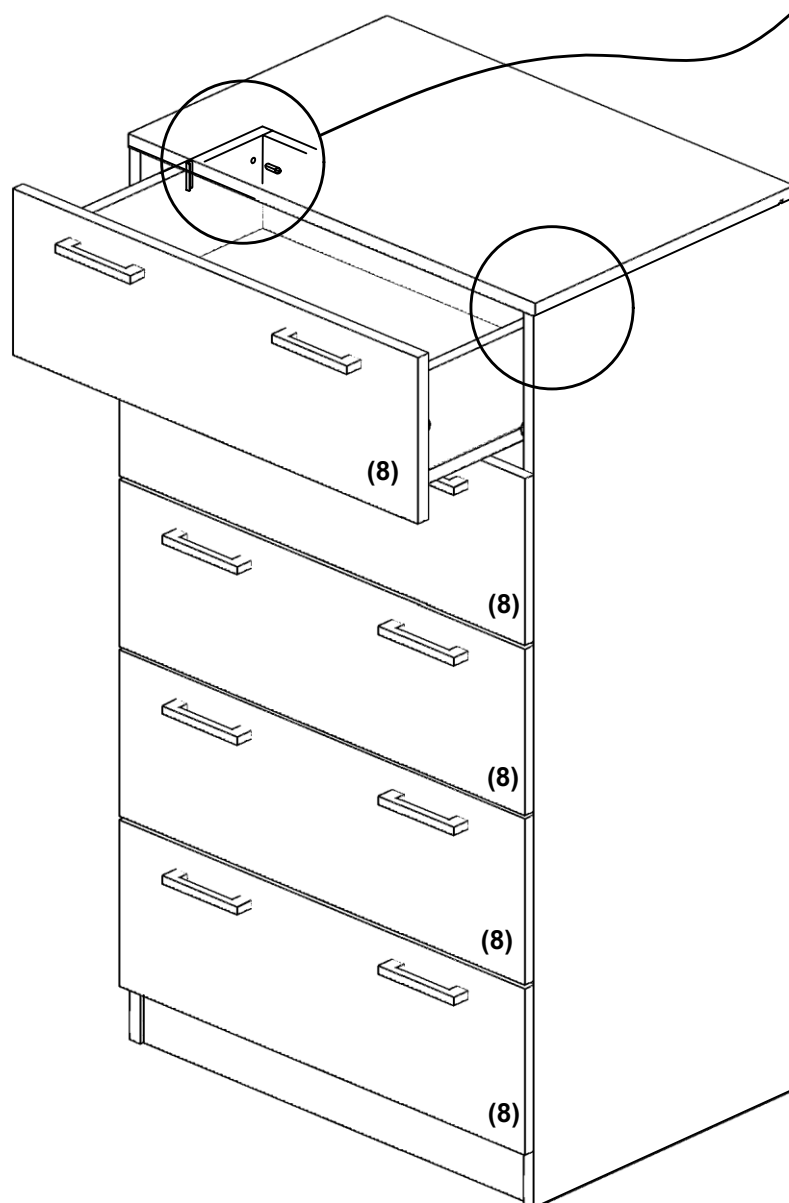

TIP : When installing the drawer stopper dowels, please make sure that the hole for the dowel is behind the metal drawer stopper to ensure correct install and drawer operates as normal

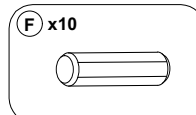

TRIBECCA 5 DRAWER CHEST

ITEM CODE : 5096

STEP 14

Attach the backply stoppers (L) to the rear panels (7) using screw (D).

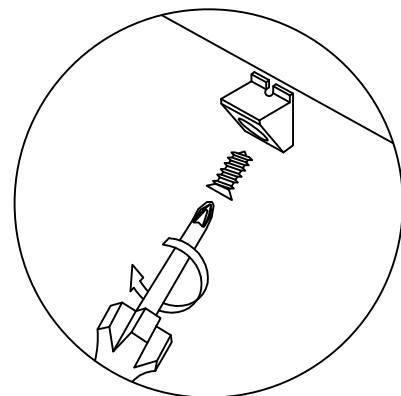
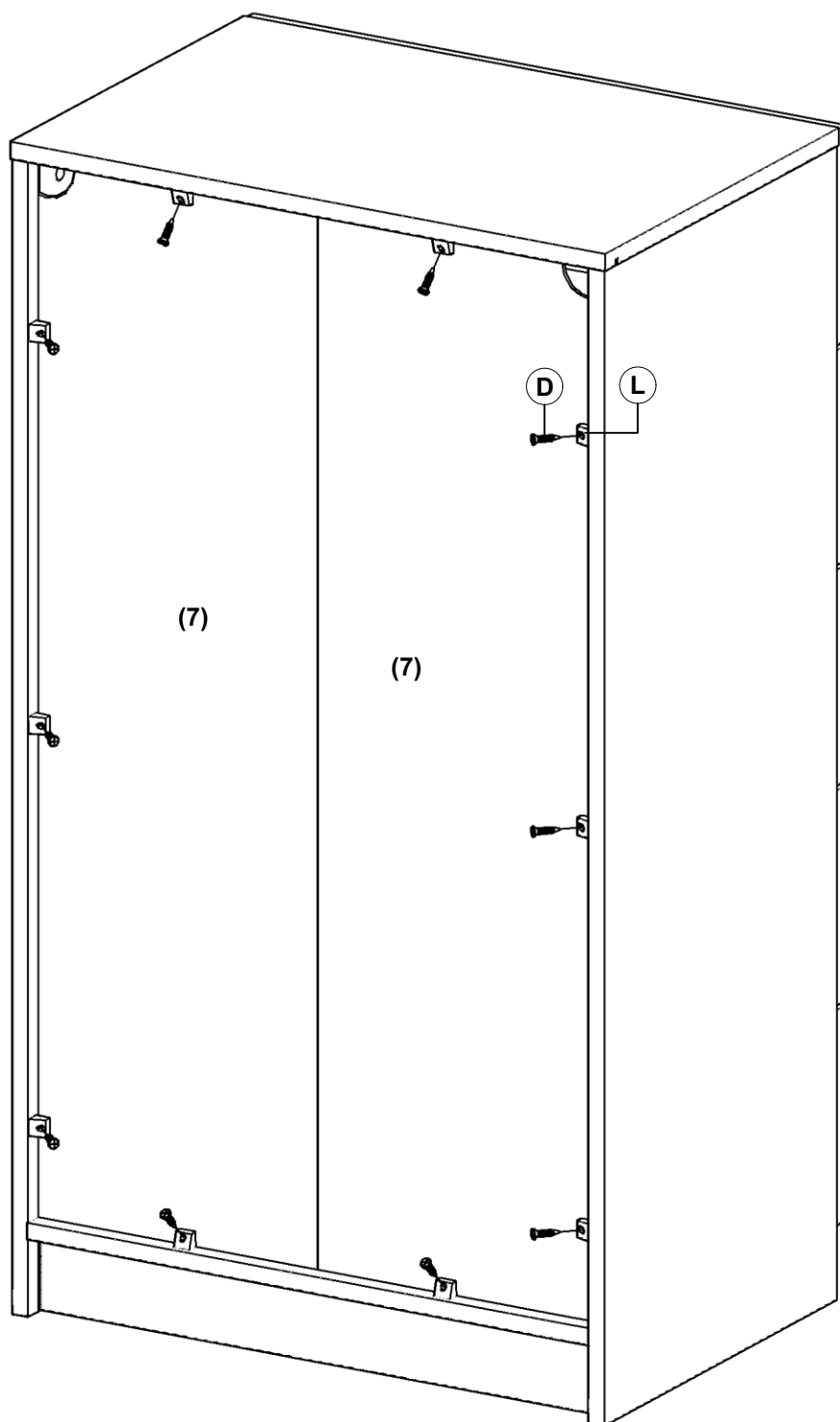

TIP : It is really important to attach the backply stoppers correctly as this will help with the overall structure and stability of the item.

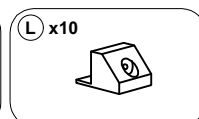
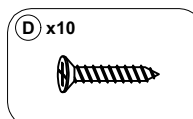

TRIBECCA 5 DRAWER CHEST

ITEM CODE : 5096

STEP 15

Bracket Fixing

The horizontal arms of the brackets are to be secured to the underside of shelf so that it is out of sight when the cabinet is installed into position.

- ☒ After assembling the unit place it against the wall where it will be permanently positioned.
- ☒ Working from inside the cabinet place the bracket through the pre-cut hole in the rear wall of the cabinet as shown in diagram.
- ☒ Use a pencil to mark through the screw hole in the bracket, where the bracket has to be attached to the wall.
- ☒ Move the cabinet away from the wall and secure the bracket to the wall at the marked position using a wall anchor suited to your wall surface.
- ☒ With the wall brackets in position, move the cabinet back to the wall allowing the horizontal arm of the bracket to enter into the cabinet through the pre-cut holes in the back wall of the cabinet.
- ☒ Then using the screw supplied, secure the horizontal arm of the brackets to the underside of the shelf.

For more information, visit www.productsafety.gov.au

! WARNING



Children have died from furniture tipover.

- ALWAYS secure it with an anchor device.
- NEVER allow children to stand, climb or hang on drawers, doors, or shelves.
- NEVER open more than one drawer at a time.
- Place heavy items down low.

NEVER put a TV on this furniture



This is a permanent label. Do not remove!

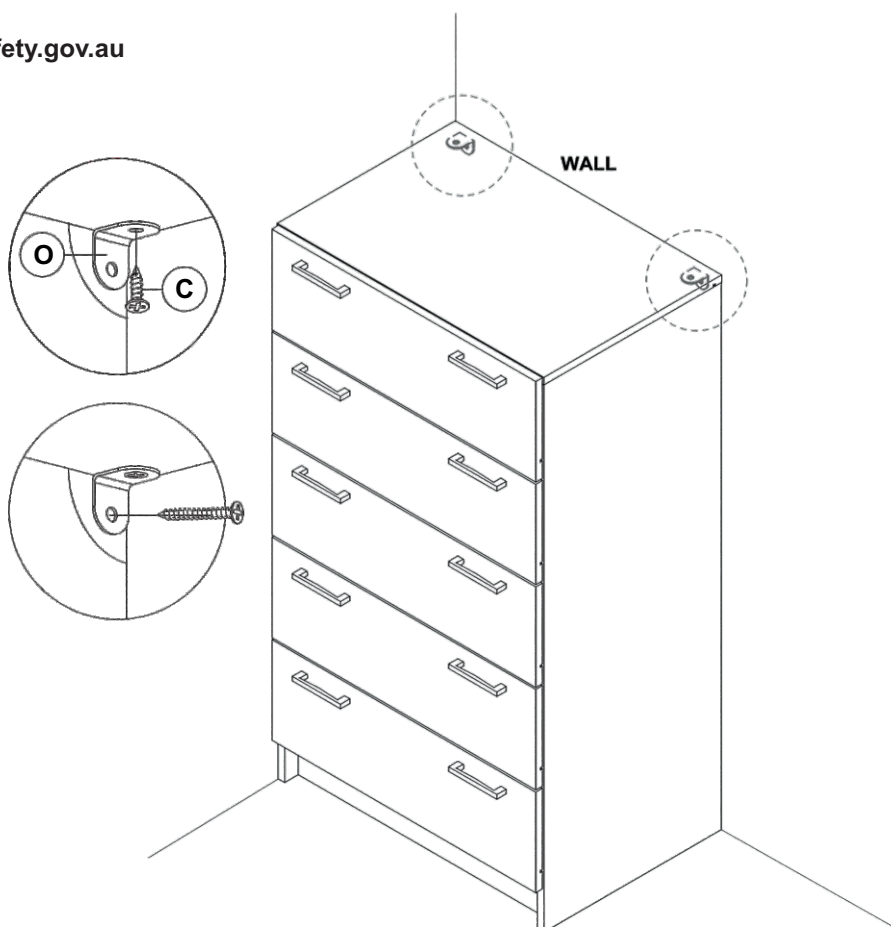

WARNING:

ENSURE THAT WALL STRAP IS ATTACHED TO AVOID SERIOUS INJURY

To avoid any serious injury, this product has been supplied with a wall strap to prevent toppling.

Wall fixings hardware are not supplied as different surface materials require different types of fixing hardware & you must use suitable fixing hardware for different type of wall you intend to mount this product to wall.

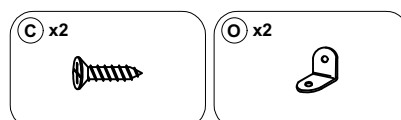

Wall Mounting & Fixing Guide

If you have any doubts about using the correct plug for your wall, please seek professional advice.

Failure of the product due to using incorrect fixings is the responsibility of the installer.



IMPORTANT:

When drilling into walls, always check for hidden wires or pipes, etc.



Tips & Tricks

**Make sure that the hardware used is suitable for supporting your unit.
Please consult a qualified tradesperson if unsure.**

- ✓ If you are unsure, please select a larger screw and wall plug.
- ✓ Ensure that you use the recommended drill bit to match the wall plug and hole size.
- ✓ Take extra care when drilling high walls, ceiling and ceramic tiles. Ensure wall plugs are inserted beyond the thickness of the ceramic tiles to avoid splitting or cracking.
- ✓ Ensure that wall plugs are well fitted and are a tight fit in the drilled hole.

Types Of Walls

Use one of the following types of wall plug (not included) if your walls are made of brick, breeze block, concrete, stone or wood. Screws may be able to be fixed directly to solid wood walls as they will provide a secure anchor point.

1. General purpose wall plug

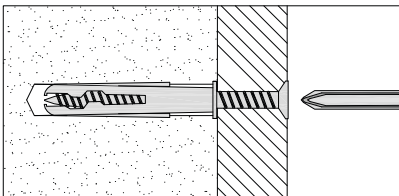

Generally aerated blocks should not be used to support heavy loads, use a specialist fitting in this case. For light loads, general purpose wall plugs can be used.

2. Plasterboard wall plug

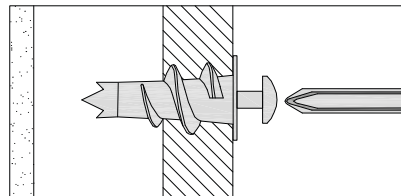

For use when attaching light loads on to plasterboard partitions or hollow wooden doors.

3. Cavity fixing wall plug

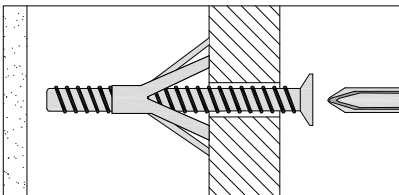

For use with plasterboard partitions or hollow wooden doors.

4. Cavity fixing-heavy duty wall plug

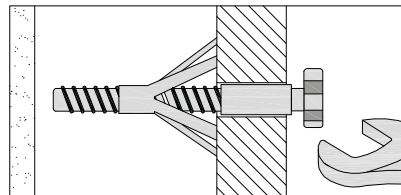

For use when fitting or supporting heavy loads such as shelving, wall cabinets and coat racks.

5. Hammer fixing wall plug

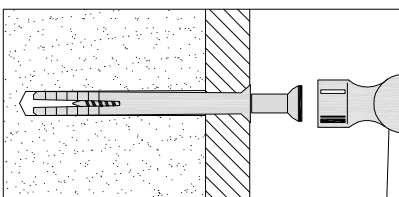

For use with walls stuck with plasterboard. The hammer fixing allows it to be fixed to the wall rather than the plasterboard. Always check the fixing is secure to the retaining wall.

6. Shield anchor wall plug - heavy loads

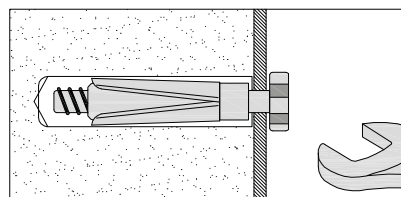

For use with heavier loads such as TV & HiFi speakers and satellite dishes etc.



Warranty Certificate

Congratulations! You have made an excellent choice of this quality product. Our commitment to quality also includes our service. Should you, contrary to expectations, experience defects due to manufacturing faults, **Meubilair Direct Imports** will provide you with a warranty against defects as follows:

Warranty

The product is guaranteed to be free from defects in workmanship and parts for a period of 12 months from the date of purchase. Defects that occur within this warranty period, under normal use and care, will be repaired, replaced or refunded at our discretion. The benefits conferred by this warranty are in addition to all rights and remedies in respect of the product that the consumer has under the Competition and Consumer Act 2010 and similar state and territory laws.

Our goods come with guarantees that cannot be excluded under the Australian Consumer Law. You are entitled to a replacement or refund for a major failure and for compensation for any other reasonably foreseeable loss or damage. You are also entitled to have the goods repaired or replaced if the goods fail to be of acceptable quality and the failure does not amount to a major failure.

Proof of Purchase

This warranty is valid for the original purchase and is not transferable. Please keep your purchase docket, tax invoice or receipt as the best proof of purchase, and as proof of date on which the purchase was made.

Normal Wear and Tear

This warranty does not cover normal wear and tear to the products or parts.

Exclusions

This warranty does not cover:

- Any defects caused by an accident, misuse, abuse, improper installation or operation, lack of reasonable care, unauthorized modification, loss of parts, tampering or attempted repair by a person not authorized by the distributor.
- Any product that has not been installed, operated or maintained in accordance with the manufacturers' operating instructions provided with the product.
- Any product that has been used for purposes other than domestic use.
- Any damage caused by improper power input or improper cable connection.

MEUBILAIR DIRECT IMPORTS PTY LTD

Customer Service

Email: cs@meubilair.com.au

Address: Unit 4, 16 Hickeys Road, Penrith, NSW, 2750

Opening hours: 9am to 4pm (Monday – Friday)

Contact Number: (02) 4701 5363

When making a return, please ensure the product is properly packaged, so as to ensure that no damage occurs to the product during transit. Please provide the original or a copy of the proof of purchase. Also please make sure you have included an explanation of the problem. Please note that the costs of making a warranty claim, including any return postage, will be covered by the supplier identified above. Please note upon receiving your warranty claim, the supplier will send, via the post or email, a repair and refurbished goods or parts notice. Please provide your email address and advise the supplier, if you wish to obtain a repair and refurbished goods or parts notice via email.

AFTER SALES SUPPORT

EMAIL : cs@meubilair.com.au

Product code: 5096-WHT / 5096-LSO





MEUBILAIR
DIRECT IMPORTS

Warranty Certificate

PRODUCT NAME: Tribeca 5 Drawer Chest

BRAND NAME:

PRODUCT CODE: 5096-WHT / 5096-LSO

NAME

ADDRESS

EMAIL

DAYTIME TEL NO

DATE OF PURCHASE

SERIAL NUMBER

We recommend that you attach a photocopy of your receipt, showing the date of purchase, to this Warranty certificate and **keep for your reference.**

In the event of a product fault, please email the Customer Service team. Please ensure that you include the product details (as shown on the card) at hand so that we are able to respond as quickly and efficiently as possible.

MEUBILAIR DIRECT IMPORTS PTY LTD

Customer Service

Email: cs@meubilair.com.au

Address: Unit 4, 16 Hickeys Road, Penrith, NSW, 2750

Opening hours: 9am to 4pm (Monday – Friday)

Contact Number: (02) 4701 5363

AFTER SALES SUPPORT

EMAIL : cs@meubilair.com.au

Product code: 5096-WHT / 5096-LSO

