

ELARA LARGE SIDEBORD

ITEM CODE: 5250R-WHT

1.5 HR

APPROXIMATE ASSEMBLY TIME

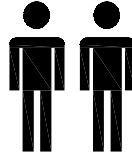

2 PERSON ASSEMBLY

FLOOR AREA
2.5M X 2.0M

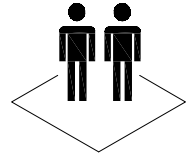

REQUIRED ASSEMBLY SPACE

REQUIRED ASSEMBLY TOOLS

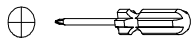

POZI SCREWDRIVER

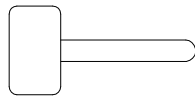

HAMMER

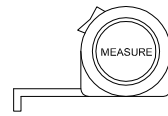

MEASURING TAPE

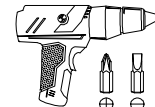

DRILL

ALWAYS USE A DRILL
WITH CARE TO AVOID
DAMAGE TO YOUR ITEM
FROM OVER TIGHTENING.

ASSEMBLED DIMENSIONS

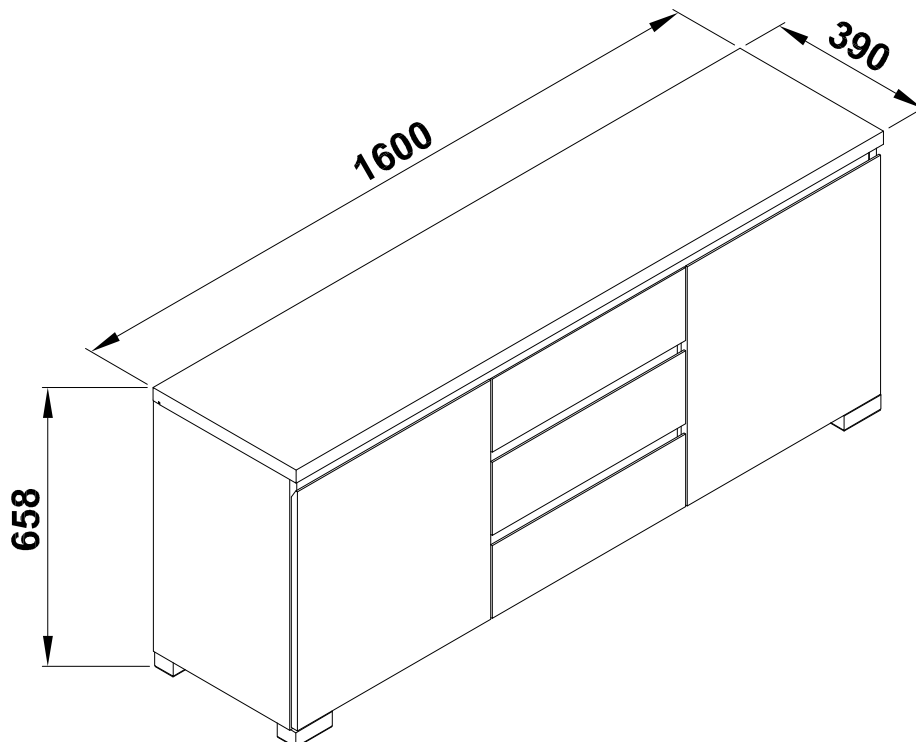

ELARA LARGE SIDEBOARD

ITEM CODE: 5250R-WHT

Tips before you start:

1. Please check that all parts are present before you start the assembly of your furniture.
2. For ease and speed of assembly, we recommend that before you commence each step of the assembly, that you identify all the parts required for that step.
3. For larger items, please ensure that you have sufficient space and people (as indicated on page 1) to assemble your product safely.
4. We recommend that, where possible, all items are assembled near to the area in which they will be placed in use, to avoid moving the product unnecessarily once assembled.
5. For the protection of your furniture, we recommend that the product is placed on a protected surface during assembly to prevent any damage.
6. During assembly please take care not to over-tighten any fittings, as this may damage the product.
7. Always place the product on a flat, steady and stable surface.
8. Do not stand on the product. Do not use the product as a stepladder.
9. This product is intended for indoor, household use only as it is non industrial product.

Care and Maintenance of your Furniture

- Please periodically check all fittings and re-tighten as necessary.
- To clean your item, please use a damp cloth and wipe clean.
- Never allow any kind of liquid to remain on your furniture. Absorption can cause wood to warp or finishes to de-laminate.
- Please do not place hot item (e.g. hot drinks) directly on to the wood surface.
- Please do not drag or pull your furniture.

ELARA LARGE SIDEBOARD

ITEM CODE: 5250R-WHT

Tips before you start:

QUICKFIT

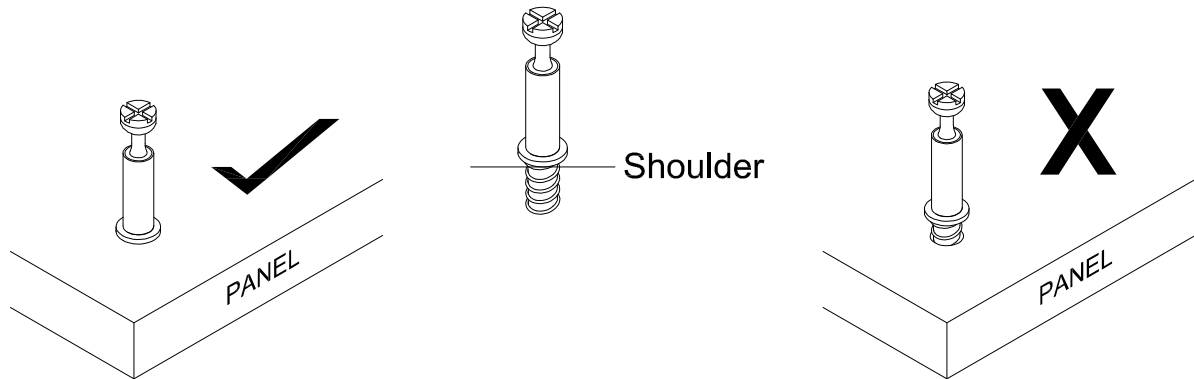

Tighten quickfit until shoulder is flush with panel. Do not overtighten or undertighten.

CAM LOCK

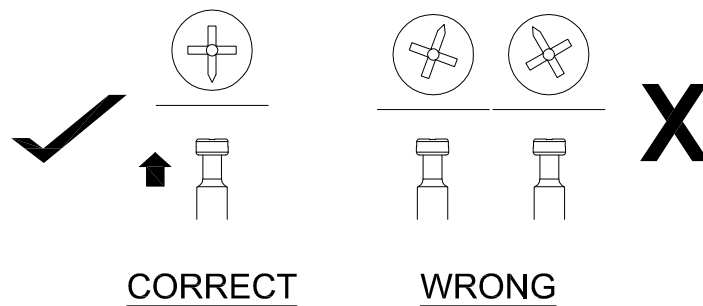

When fitting cam lock, ensure starting position is correct before you insert connecting quickfit.

Quickfit head should be in the centre of the cam lock when the two panels are joined.

Cam lock should be inserted before quickfit.

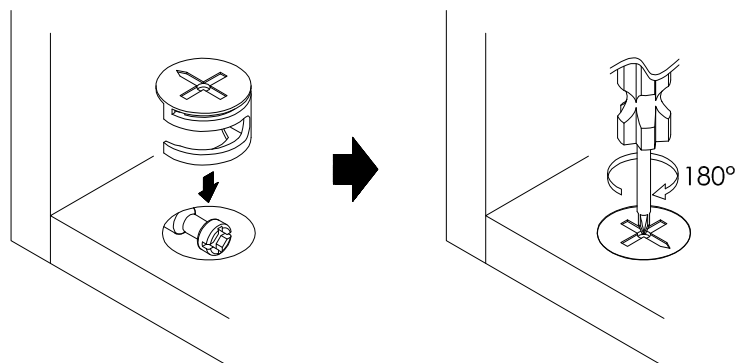

Turn camlock clockwise to tighten.

ELARA LARGE SIDEBOARD

ITEM CODE: 5250R-WHT

Drawer Installation Guide

- Before you insert the drawers into the frame, please ensure that the ball bearing sliders (on the assembled unit) have been placed to the front of the main unit. If the bearings are in the middle of the slider it will be difficult to install the drawers correctly.

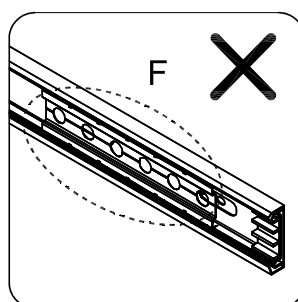
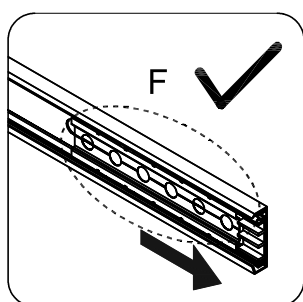

- Insert the drawer into the assembled frame as show below. Keep each side of the drawer straight and aligned correctly to the sliders on the assembled frame.

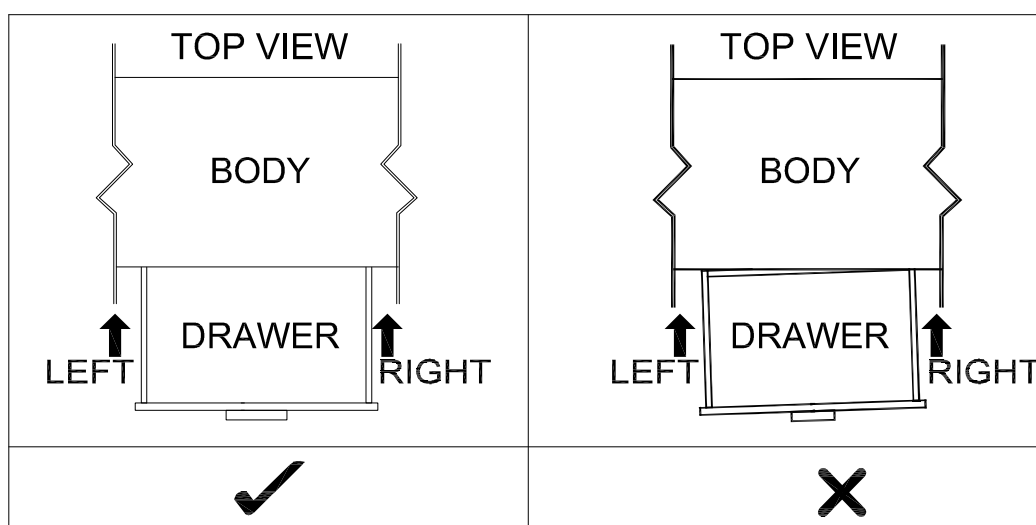

- Gently start to push the drawer into position, the drawer sliders should start to connect with the sliders on the assembled frame. Once connected apply even pressure to each side and gently push the drawer into place.
- The ball bearings should catch the drawer sliders, once they do you may find that you need to apply more pressure, this is perfectly normal as long as you are keeping the drawers straight, push the drawers 100% of the way in. Finally slide drawer in and out a few times to ensure the ball bearings are running smoothly in the slider. Installation is complete.
- At any stage throughout the install process you feel like the drawers are not evenly sliding into the assembled frame, please remove the drawers before they start to attach to the bearing slider and start the install steps again.

ELARA LARGE SIDEBOARD

ITEM CODE: 5250R-WHT

NOTE:

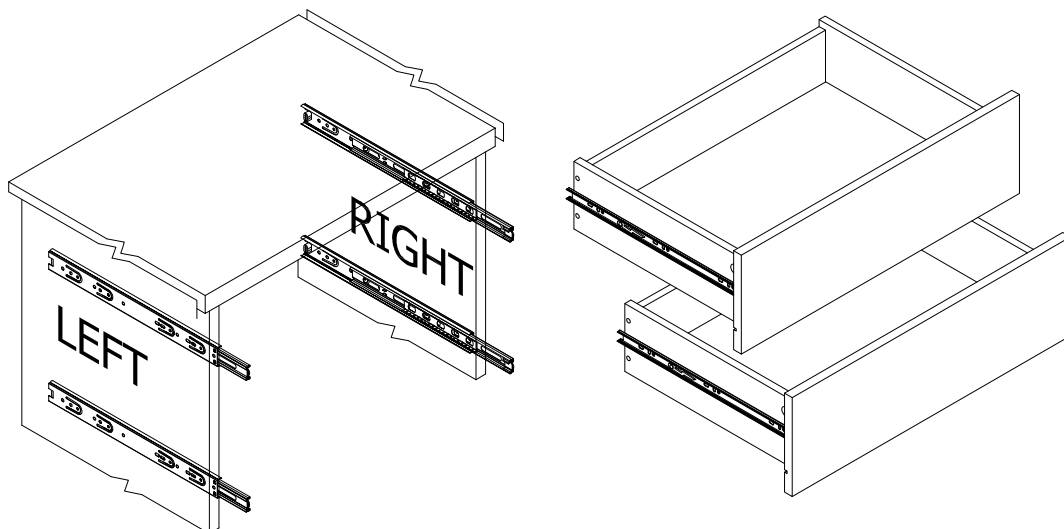
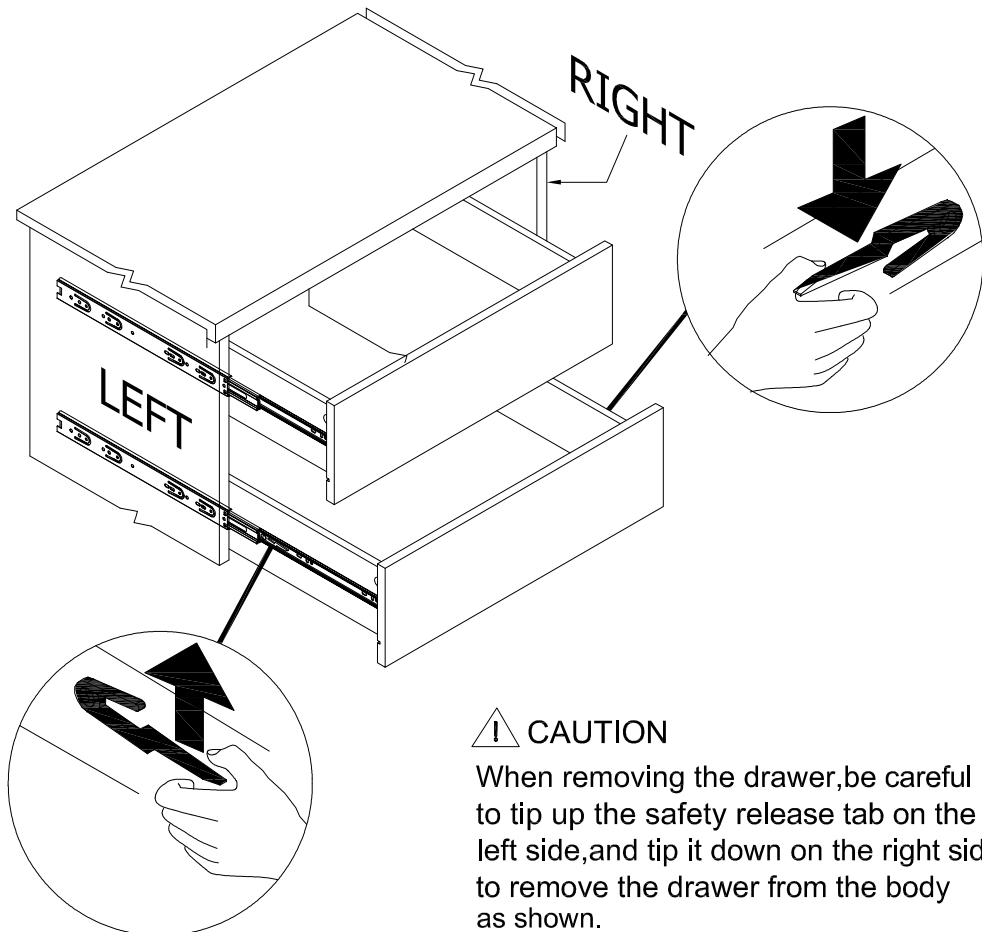

ELARA LARGE SIDEBORD

ITEM CODE: 5250R-WHT

PART LIST:

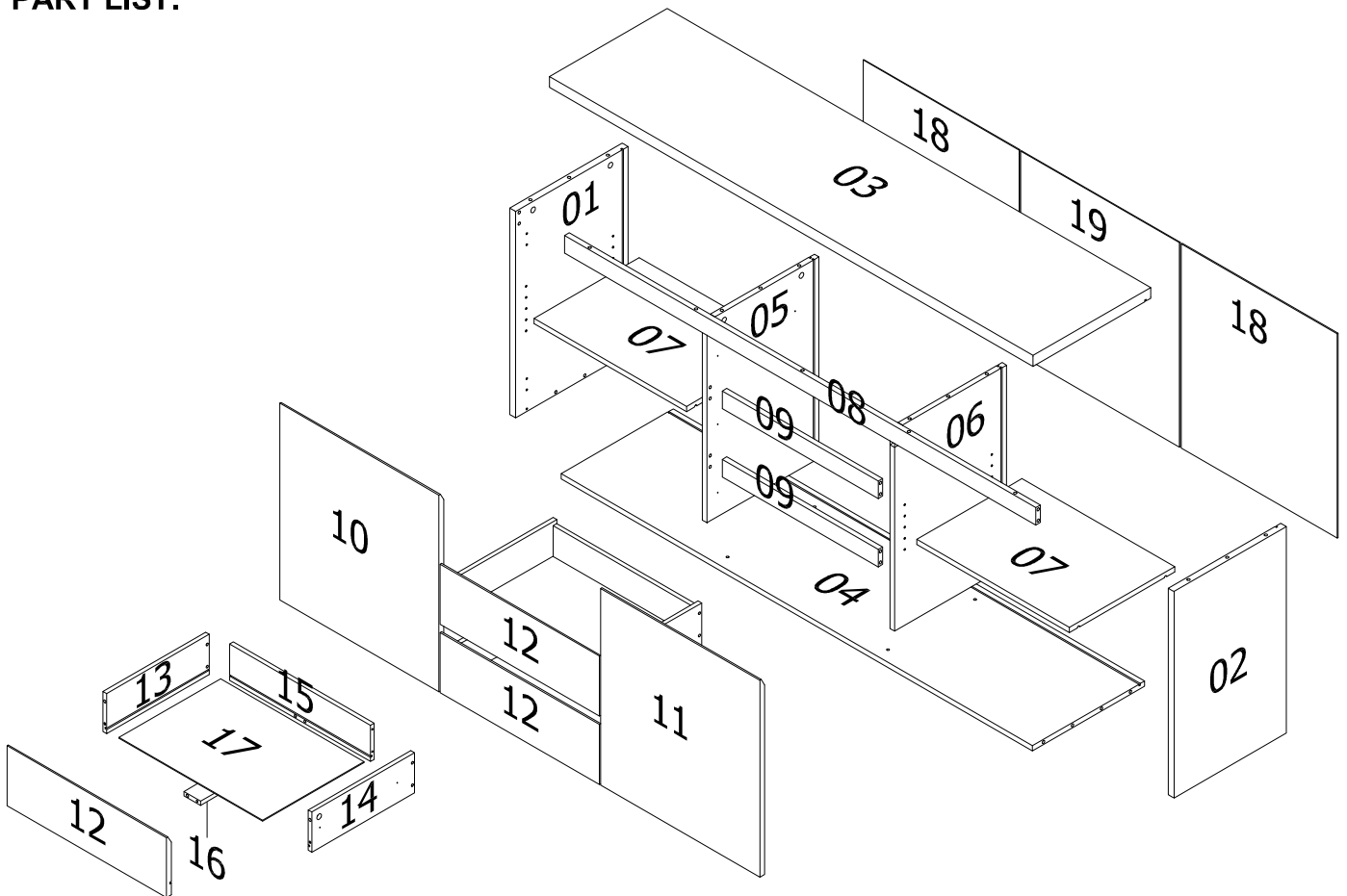

NO.	PART NAME	QTY	NO.	PART NAME	QTY
1	SIDE PANEL (LEFT)	1	11	DOOR PANEL (RIGHT)	1
2	SIDE PANEL (RIGHT)	1	12	DRAWER FRONT	3
3	TOP PANEL	1	13	DRAWER SIDE (LEFT)	3
4	BOTTOM PANEL	1	14	DRAWER SIDE (RIGHT)	3
5	DIVIDER PANEL (LEFT)	1	15	DRAWER BACK	3
6	DIVIDER PANEL (RIGHT)	1	16	DRAWER BOTTOM RAIL	3
7	SHELF PANEL (SIDE)	2	17	DRAWER BOTTOM	3
8	FRONT PANEL (TOP)	1	18	BACK PANEL (SIDE)	2
9	FRONT PANEL (CENTER)	2	19	BACK PANEL (CENTER)	1
10	DOOR PANEL (LEFT)	1			

ELARA LARGE SIDEBOARD

ITEM CODE: 5250R-WHT

HARDWARE LIST

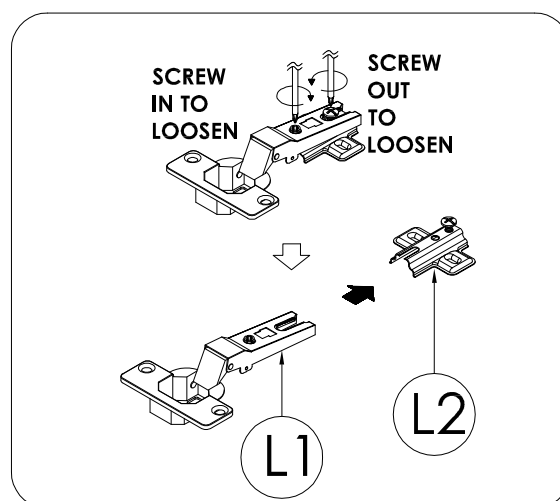
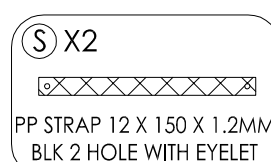
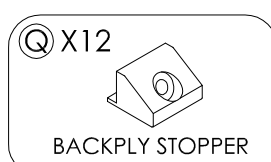
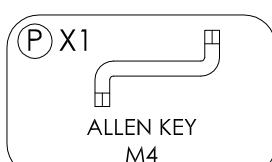
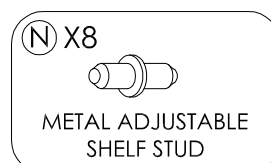
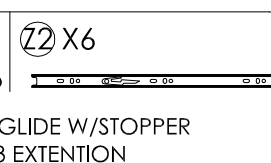
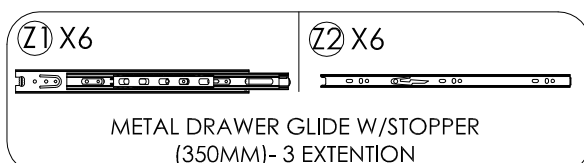
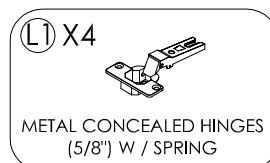
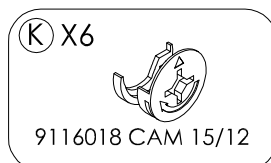
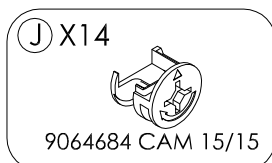
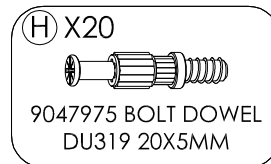
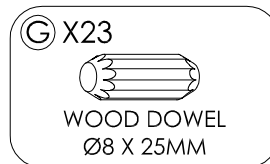
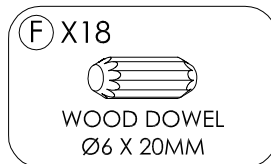
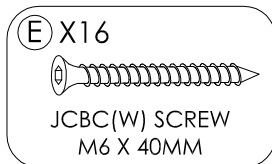
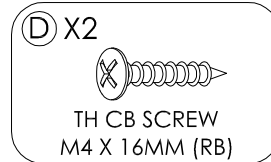
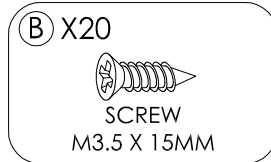
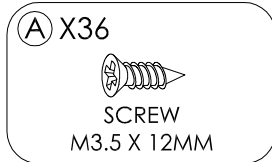

L1 & L2

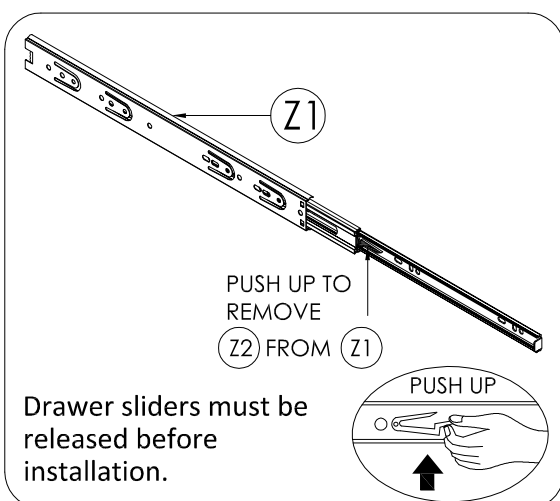

Drawer sliders must be released before installation.

Z1 & Z2

ELARA LARGE SIDEBOARD

ITEM CODE: 5250R-WHT

STEP 1

Insert dowel (G) into panels (1, 2, 4, 5, 6, 8 & 9) and wood dowel (F) into panels (13, 14 & 16) as shown.

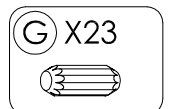
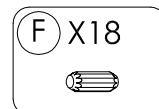
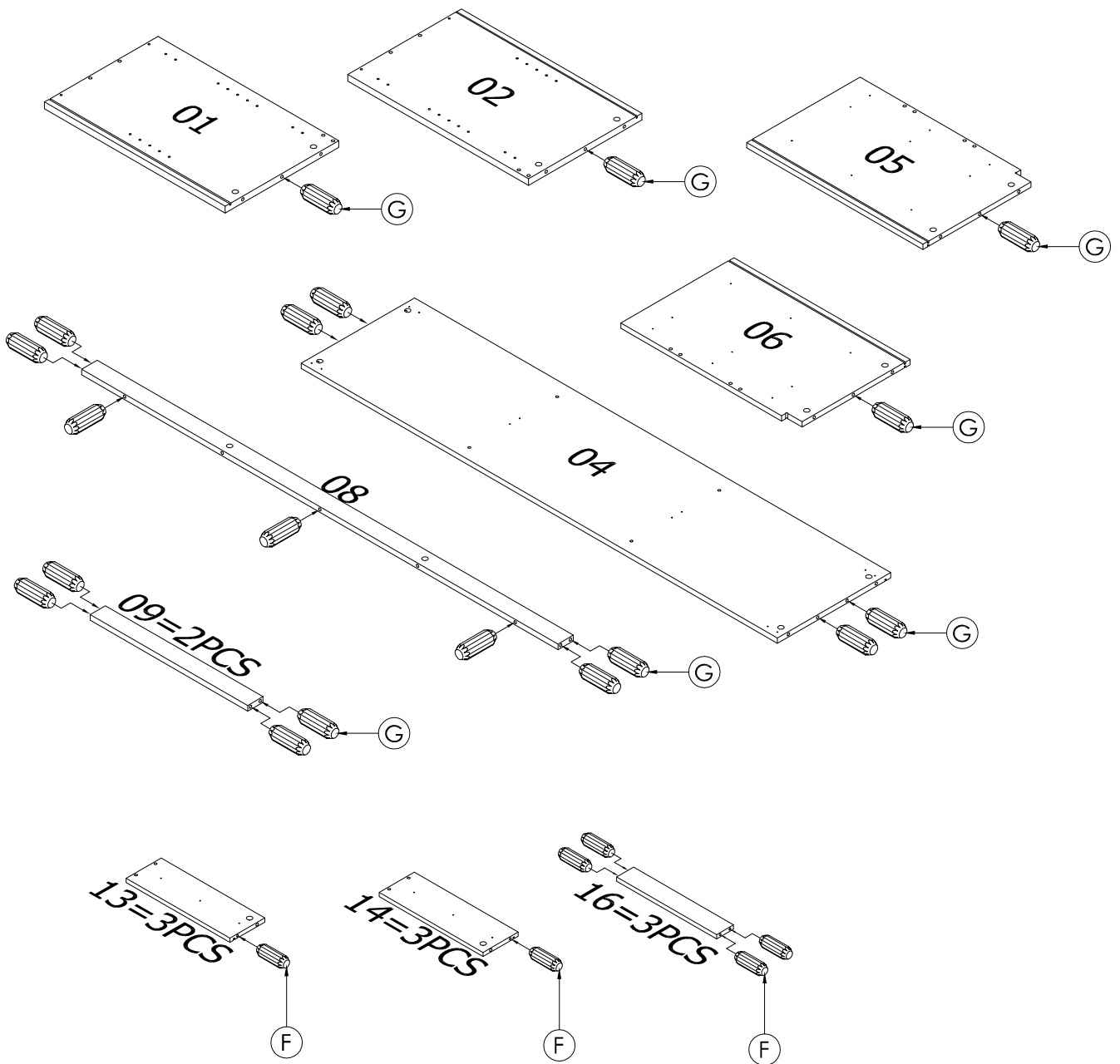

ELARA LARGE SIDEBOARD

ITEM CODE: 5250R-WHT

STEP 2

Take all panels (1, 2, 3 & 12), using a drill on low speed / torque or a phillips head screw driver CAM PINS (H) as shown. Attach hinges plate (L2) to panel (1 & 2) using screw (C) as shown.

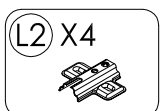
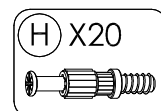
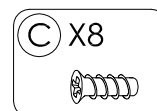
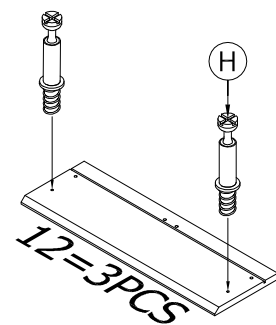
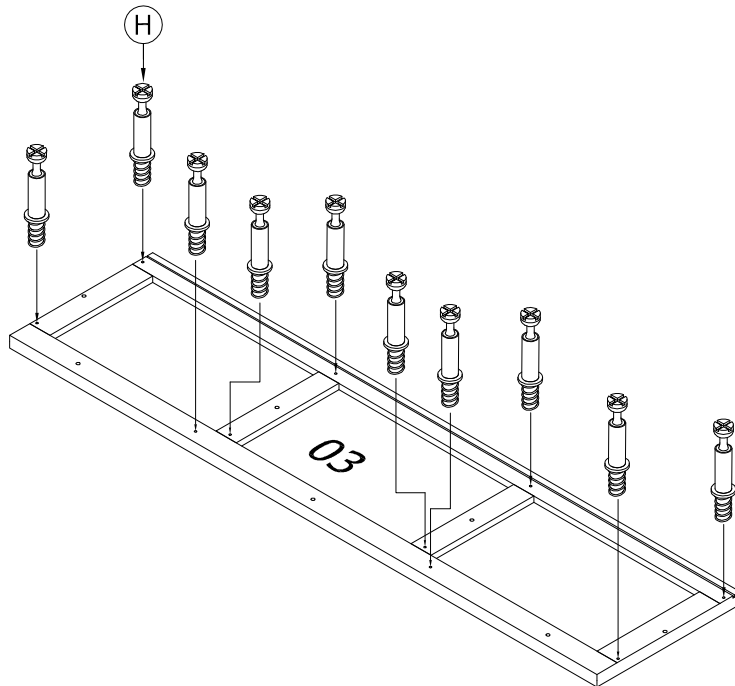
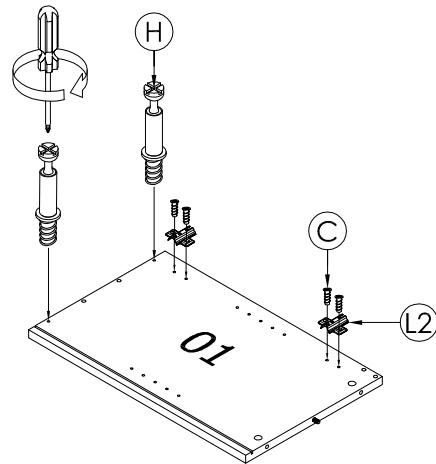
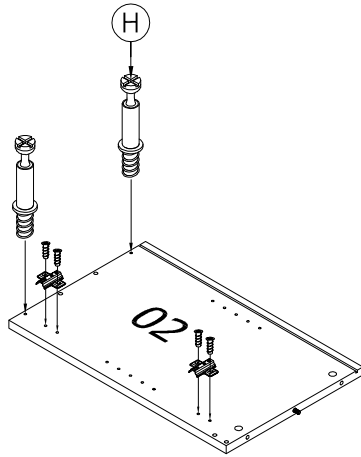
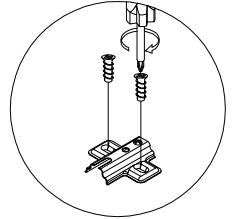

ELARA LARGE SIDEBOARD

ITEM CODE: 5250R-WHT

STEP 3

Attach drawer side (13 & 14) and drawer back (15) using 40mm screw (E). Then attach support panel (16) to drawer back (15) as shown.

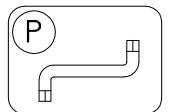
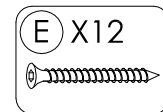
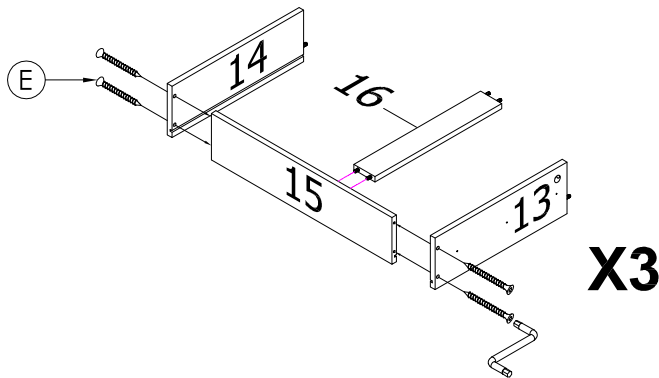
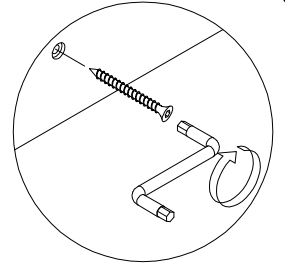

STEP 4

Slot the drawer bottom (17) into the drawer body.

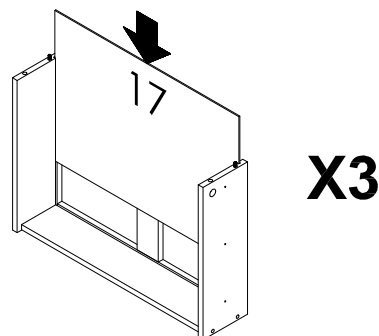

ELARA LARGE SIDEBOARD

ITEM CODE: 5250R-WHT

STEP 5

Attach drawer front (12) to side of the drawer.
Then insert the 13mm CAM LOCK (K) into holes on the sides of the drawer as shown.

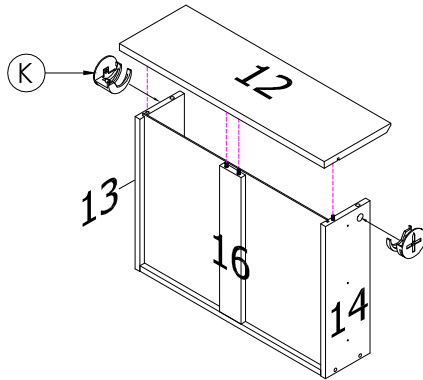

X3

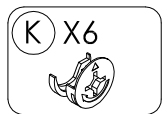
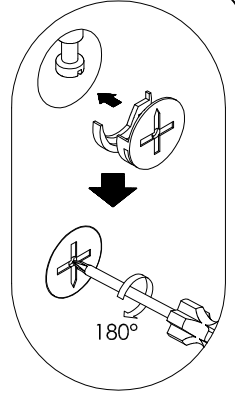

STEP 6

Attach drawer glide insert (Z2) to the drawer sides (13 & 14) with the 12mm screw (A) ensuring the correct holes as shown in diagram.

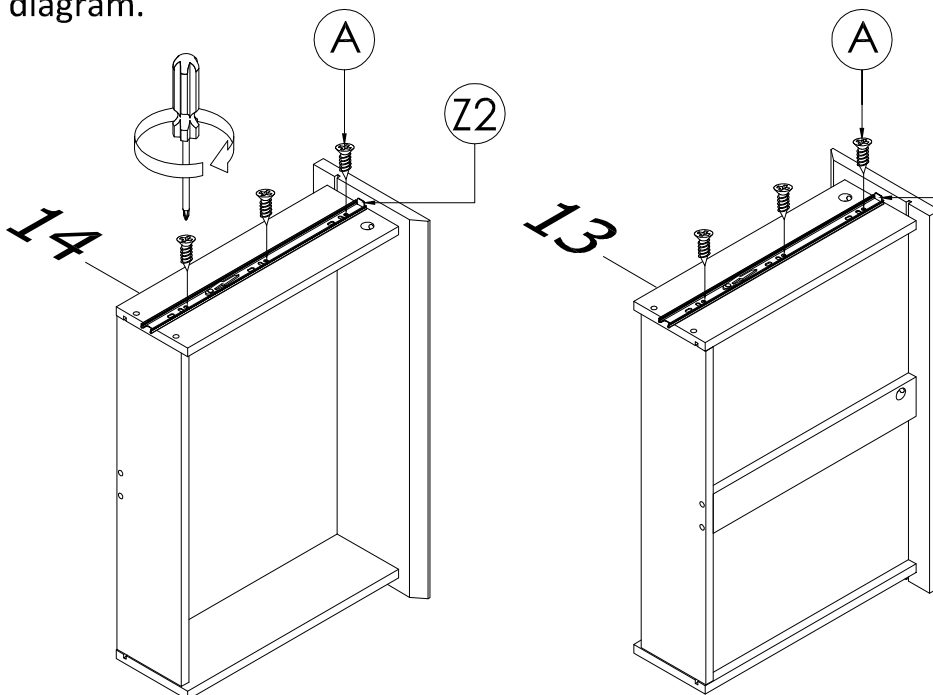

X3

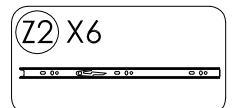
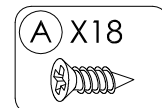
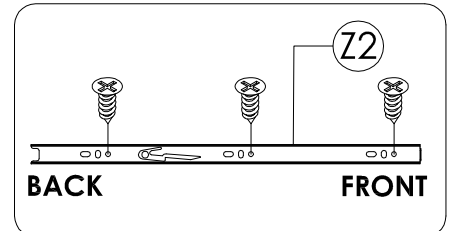

ELARA LARGE SIDEBOARD

ITEM CODE: 5250R-WHT

STEP 7

Attach drawer glide casing (Z1) to panel (5 & 6) using 12mm screw (A) as shown.

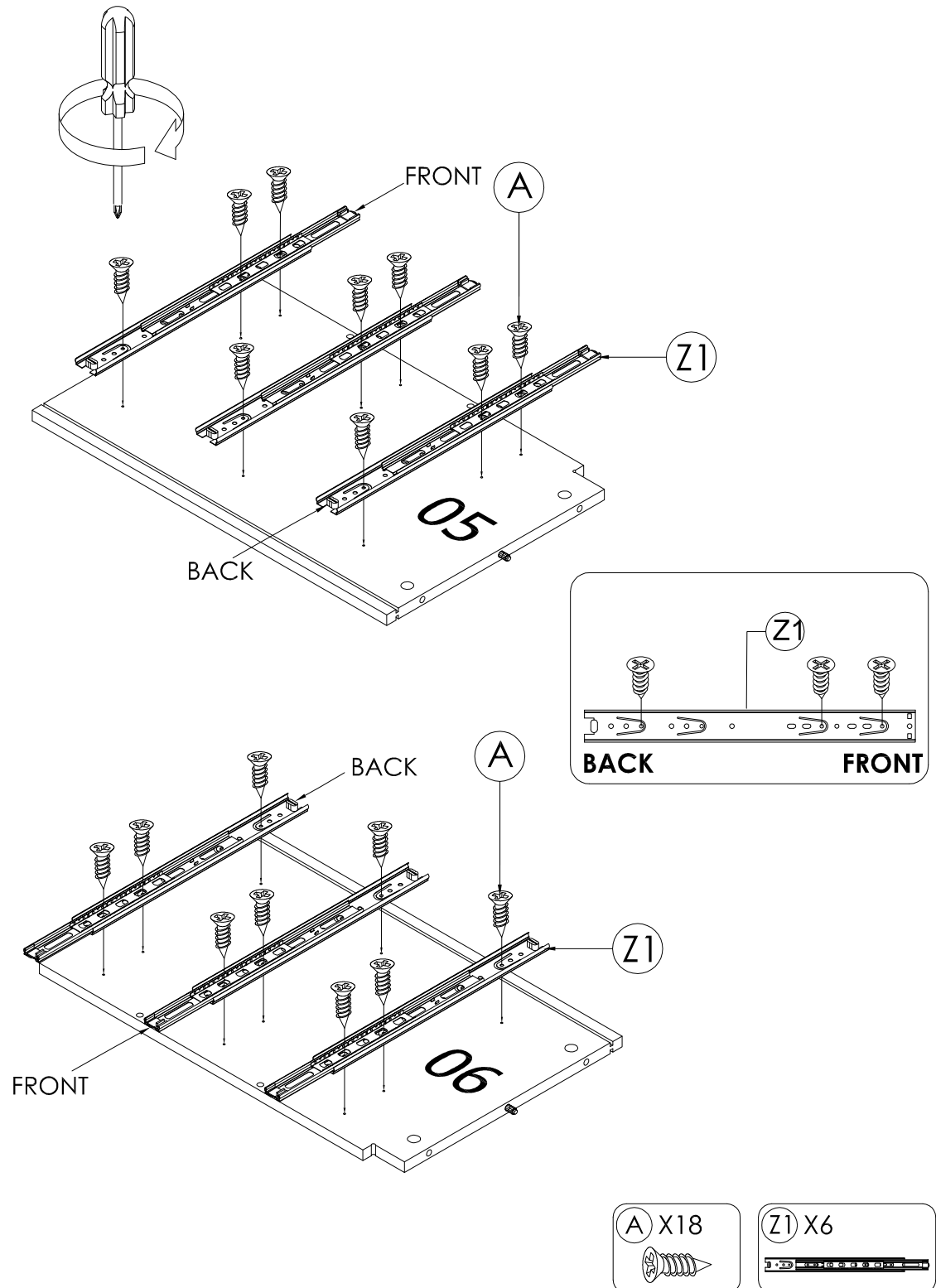

ELARA LARGE SIDEBOARD

ITEM CODE: 5250R-WHT

STEP 8

Attach front panel center (9) to divider panel (5 & 6). Then attach panel (4) to panel (5 & 6) with 40 mm screw (E) as shown.

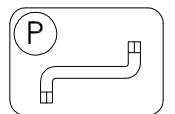
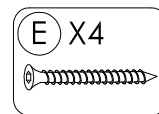
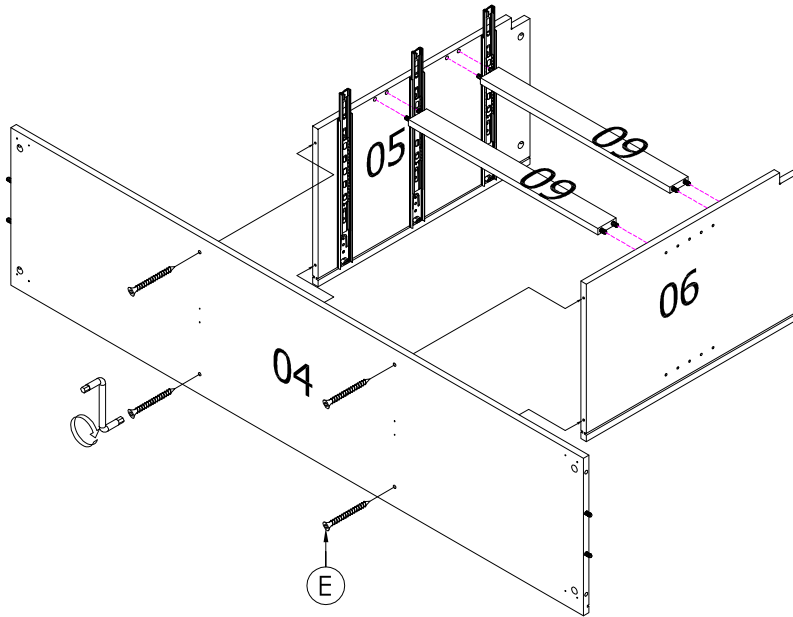
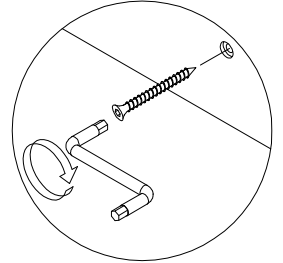

STEP 9

Attach panels (1) to panel (4) using CAM LOCK (J).

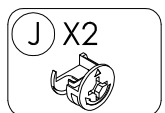
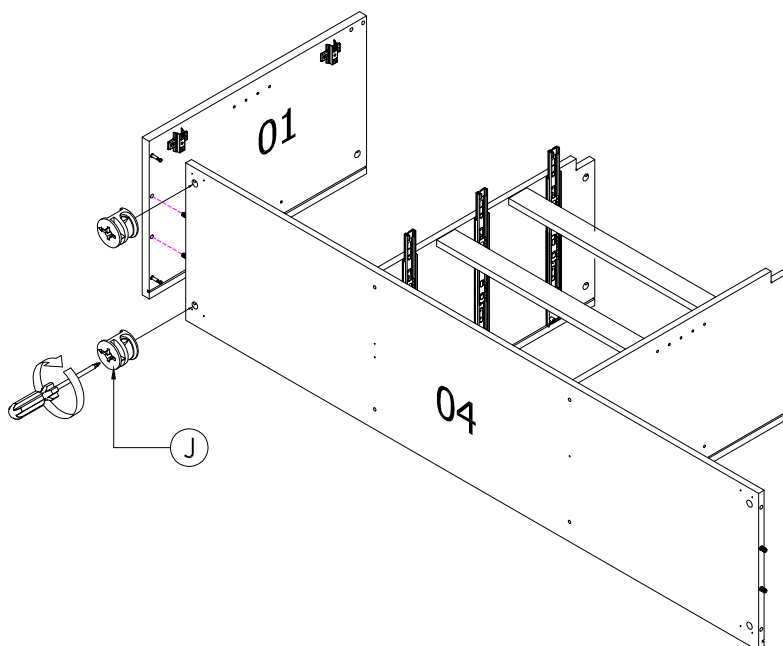
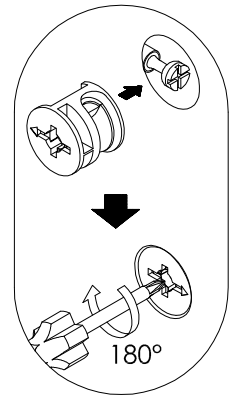

ELARA LARGE SIDEBOARD

ITEM CODE: 5250R-WHT

STEP 10

Attach front panel center (8) to divider panel (1 & 2).
Then attach panel (2) to panels (4) using CAM LOCKS (J).

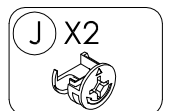
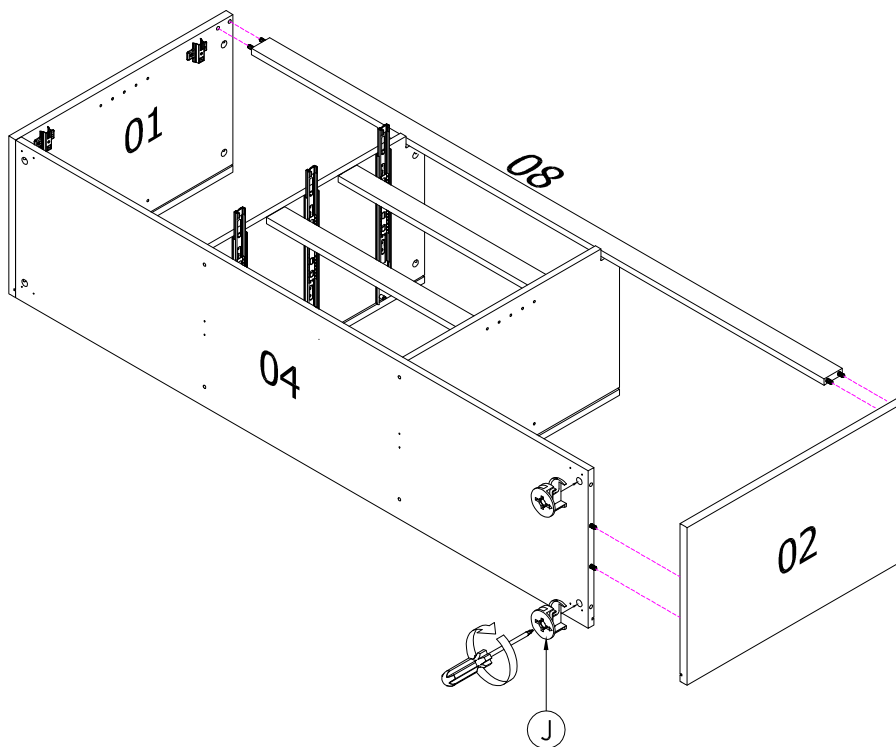
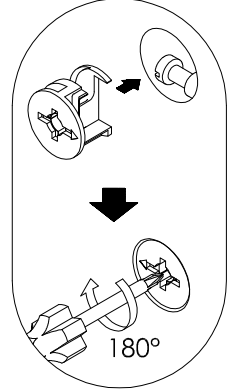

ELARA LARGE SIDEBOARD

ITEM CODE: 5250R-WHT

STEP 11

Attach rectangle leg (M) to bottom panel (4) as shown. Then attach plastic leveller (R) to center support panels (5 & 6) as shown.

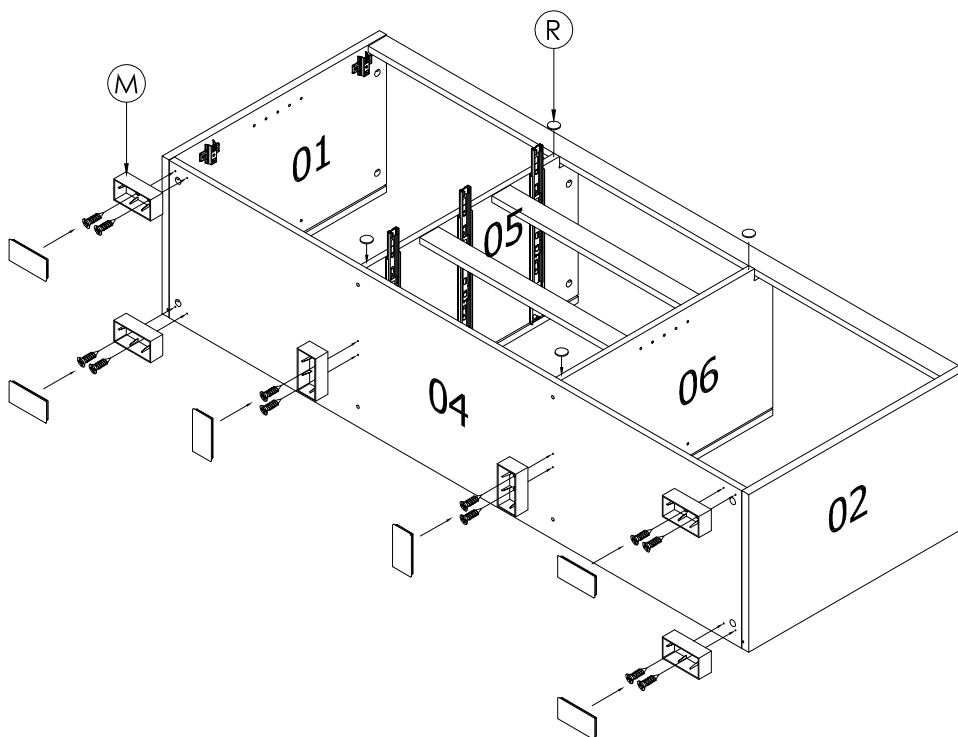
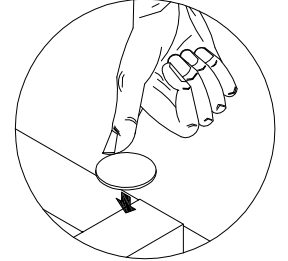

STEP 1

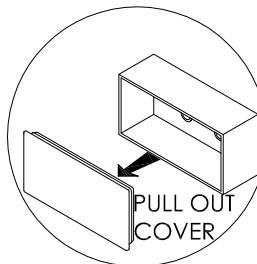

STEP 2

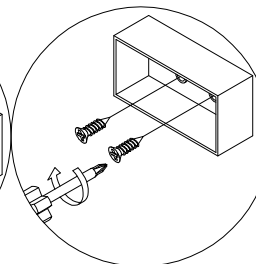

STEP 3

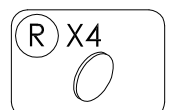
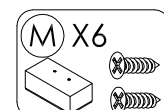
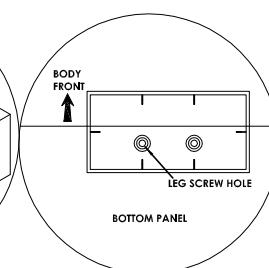
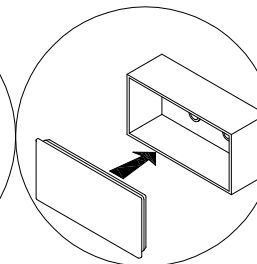

ELARA LARGE SIDEBOARD

ITEM CODE: 5250R-WHT

STEP 12

Slot back panel (18 & 19) to frame.

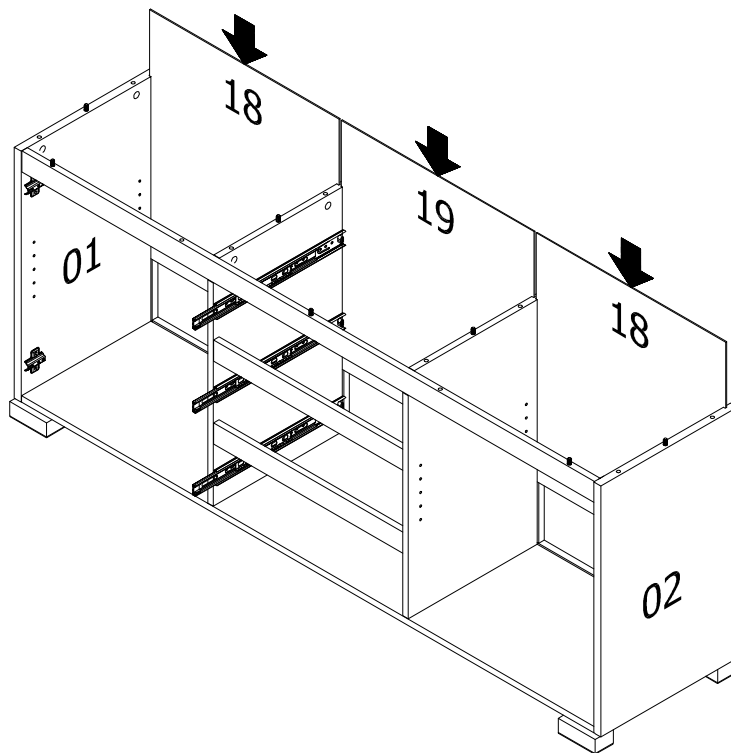

ELARA LARGE SIDEBOARD

ITEM CODE: 5250R-WHT

STEP 13

Attach top panel (3) to body frame. Fasten into place using CAM LOCKS (J) as shown.

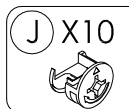
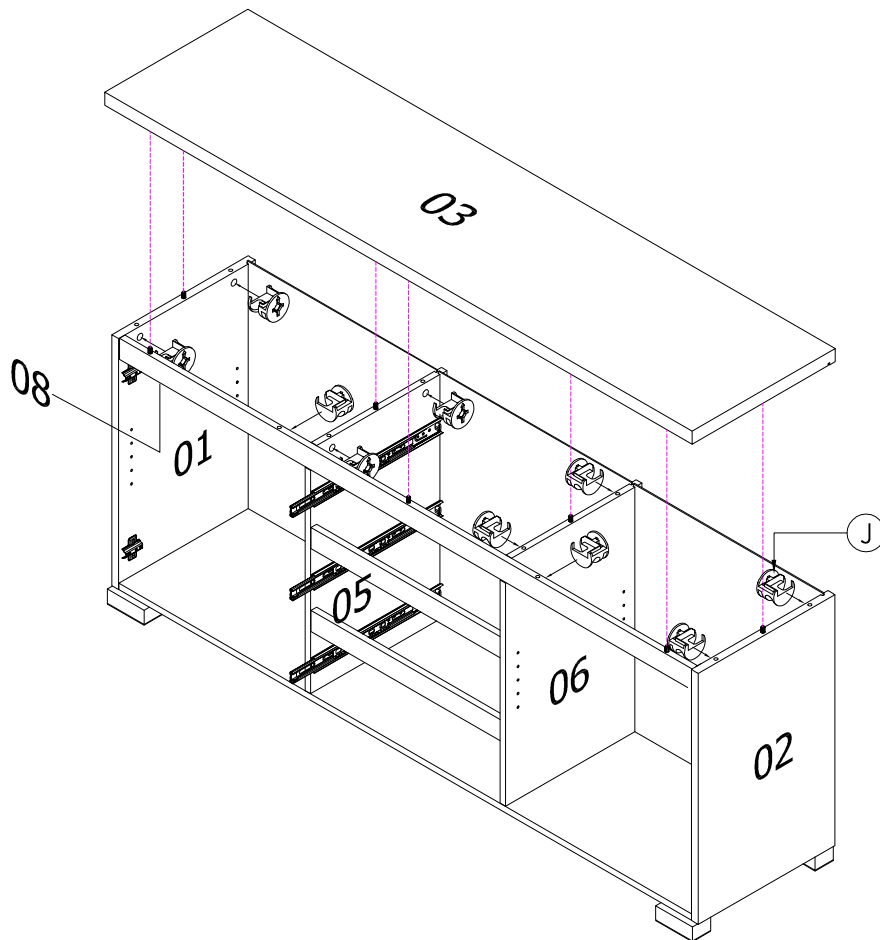
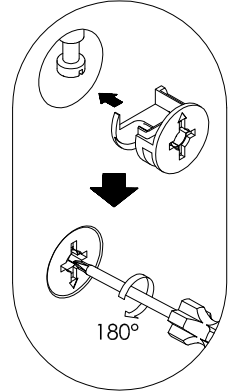

ELARA LARGE SIDEBOARD

ITEM CODE: 5250R-WHT

STEP 14

Slot the shelf panel (7) into the body after fix in the metal adjustable shelf stud (N) on the holes as shown.

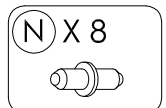
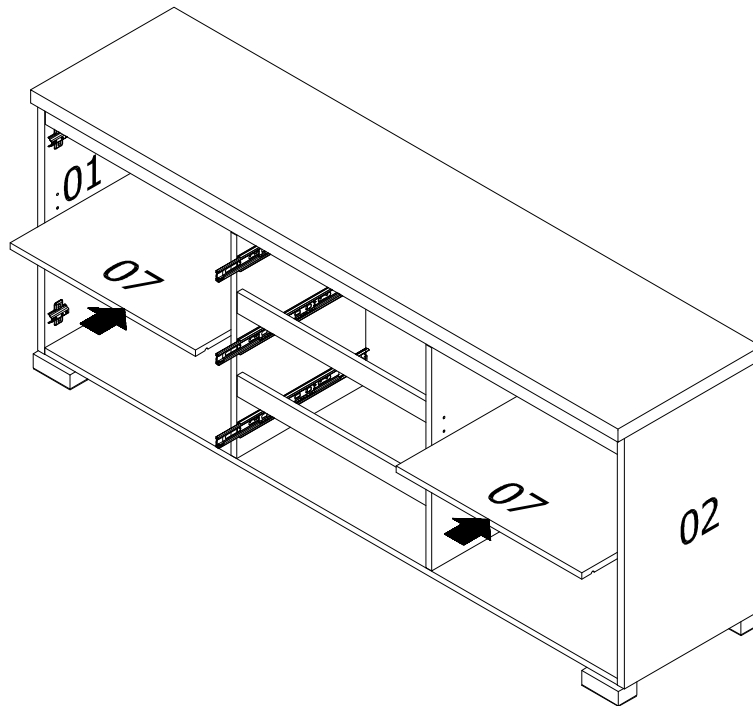
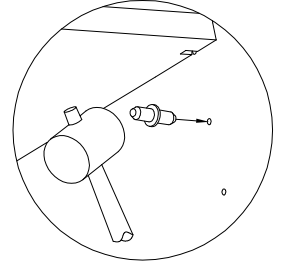

STEP 15

Attach hinges (L1) to door panel (10 & 11) using screw (B).

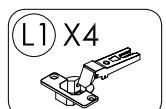
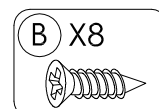
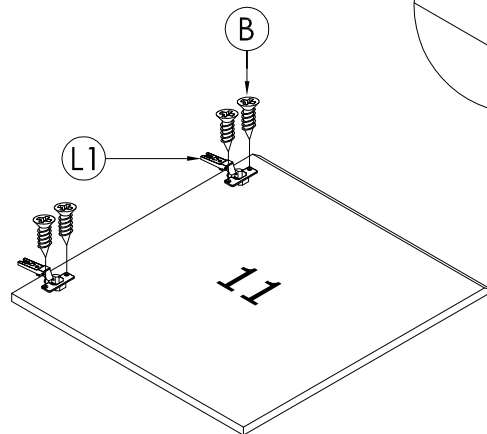
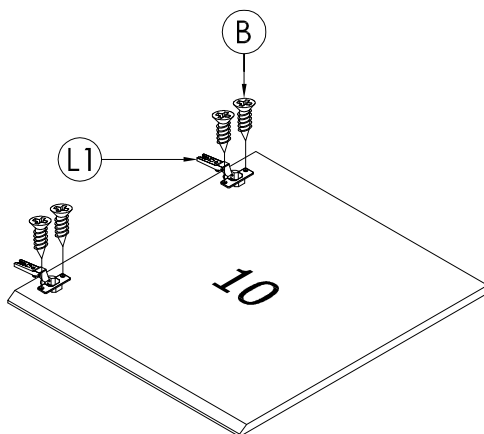
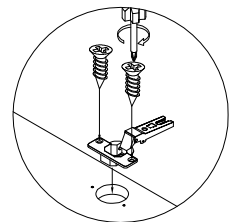

ELARA LARGE SIDEBOARD

ITEM CODE: 5250R-WHT

STEP 16

Attach the door panel (10 & 11) to side panel (1 & 2) as shown.

When installing the door hinge (L1) over the hinge plate (L2) during the build process to attach the door, please ensure the U shape slot on the hinge plate (L2) slides over the middle pin on the door hinge as shown.

Incorrect placement of this middle pin will result in your hinges not functioning properly.

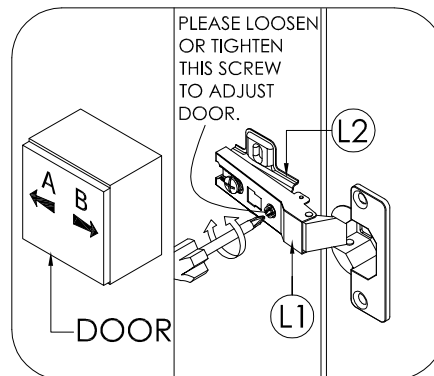
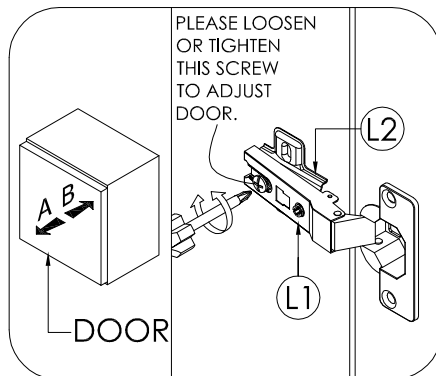
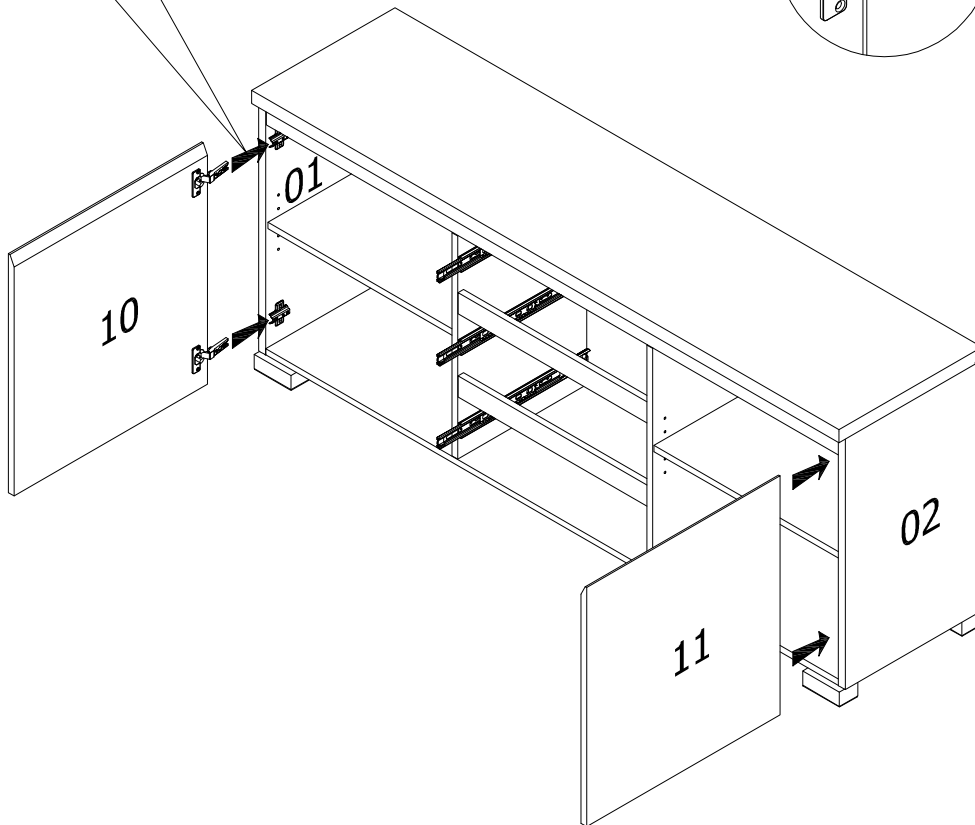
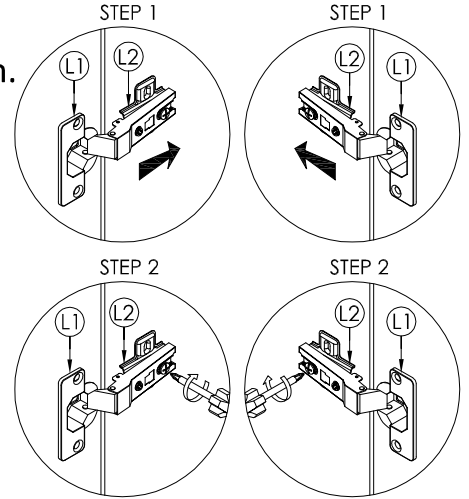
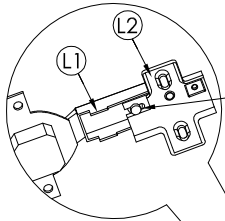

ELARA LARGE SIDEBOARD

ITEM CODE: 5250R-WHT

STEP 17

Insert the completed drawer boxes into the frame.

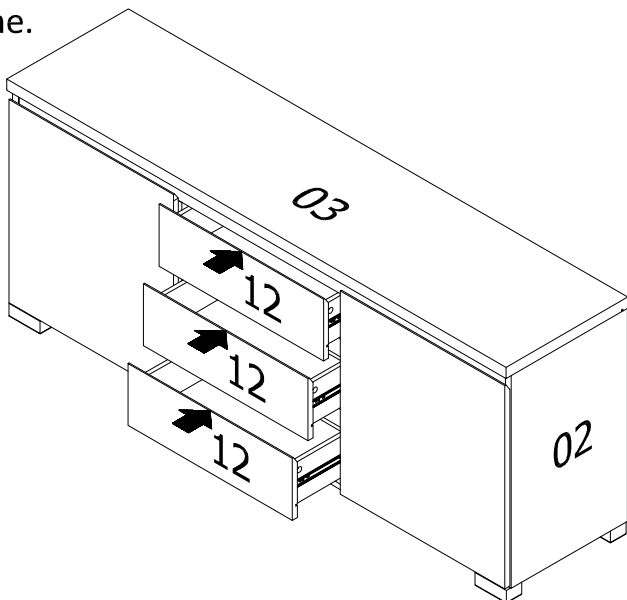

A

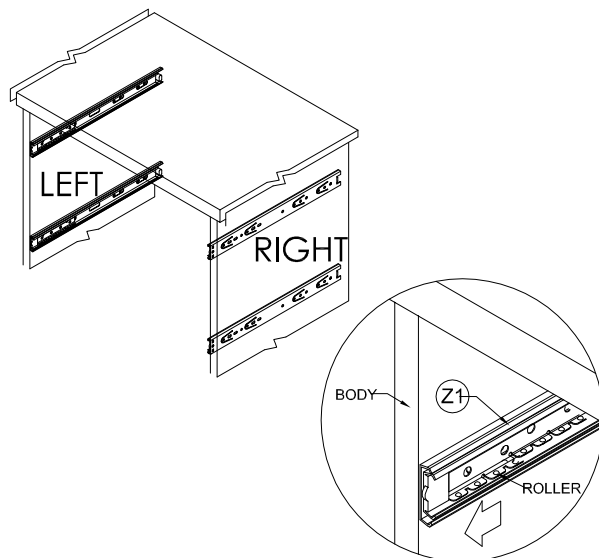

- PUSH THE ROLLER OF Z1 TO THE FRONT SIDE OF THE BODY.

B

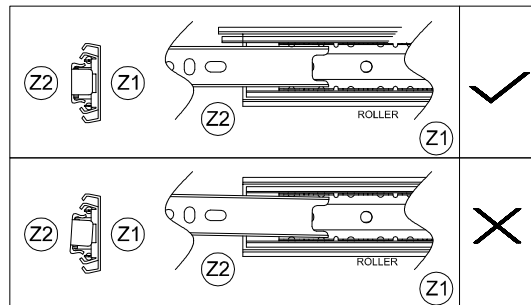
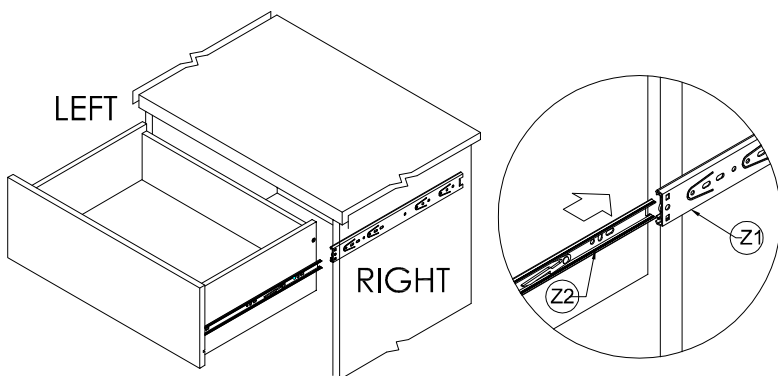

- ALIGN Z2 ON LEFT & RIGHT TO Z1 AT THE CORRECT POSITION.

C

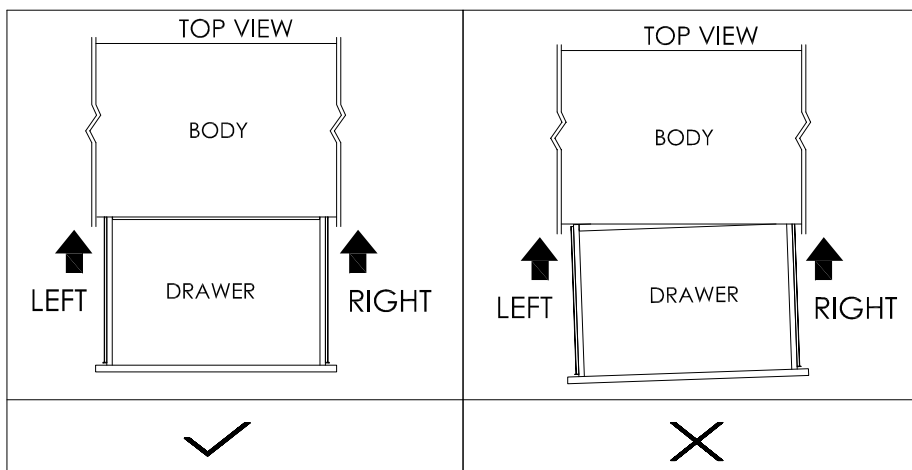

- PUSH IN LEFT & RIGHT SIDE OF THE DRAWER INTO THE BODY SIMULTANEOUSLY.
- WHEN THE DRAWER IS PUSHED IN HALF WAY, THE STOPPER ON Z2 WILL BE ENGAGED INTO Z1. THIS WILL CAUSE THE PUSHING A BIT TIGHT. (PULL OUT THE DRAWER A LITTLE BIT AND SLOWLY PUSH IN THE DRAWER AGAIN TO CHECK WHETHER THE DRAWER IS STUCK/ THE DRAWER GLIDE IS INSTALLED CORRECTLY.)
- DO NOT PUSH IN THE DRAWER IF THE DRAWER IS STUCK OR CANNOT BE PUSHED IN SMOOTHLY. TAKE OUT THE DRAWER AND REPEAT STEP 1 & 2.

ELARA LARGE SIDEBOARD

ITEM CODE: 5250R-WHT

STEP 18

Attach backply stopper (Q) to the back panel (18 & 19) using 15mm screw (B). Then attach pp strap (S) to top panel (3) with 16mm screw (D) as shown.

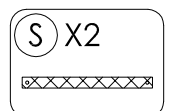
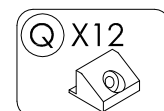
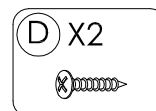
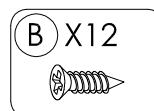
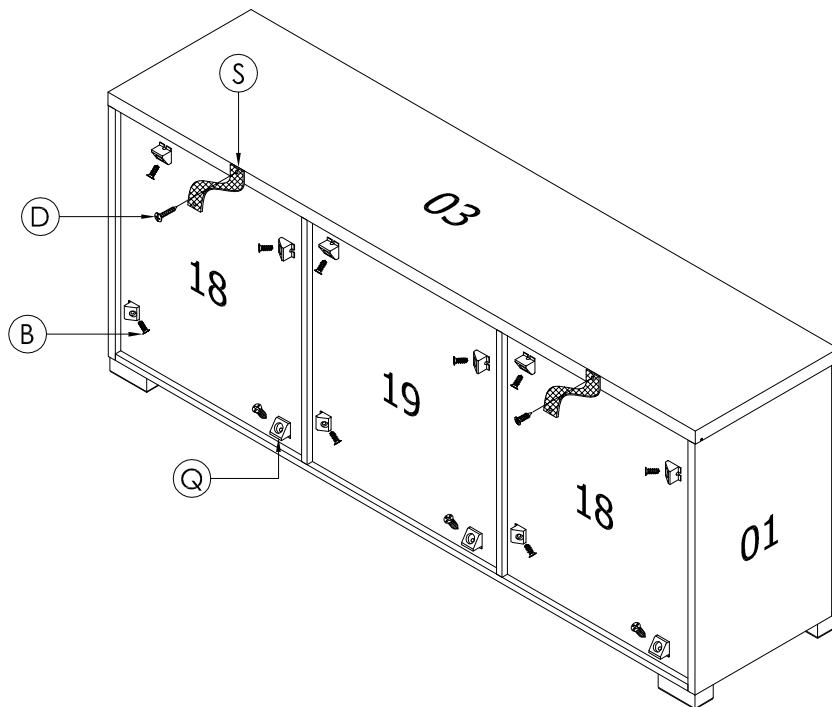
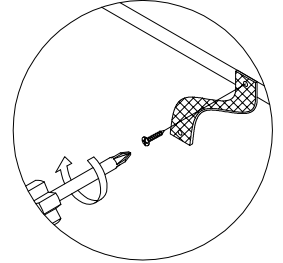
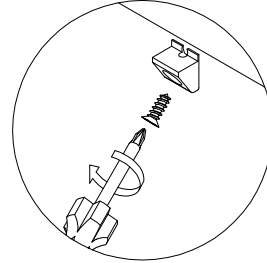

ELARA LARGE SIDEBOARD

ITEM CODE: 5250R-WHT

ASSEMBLY IS COMPLETE

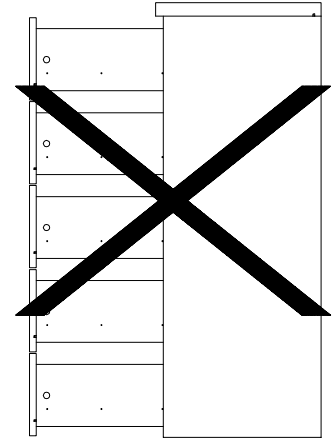

CAUTION :
PLEASE DO NOT FULLY OPEN
DRAWERS SIMULTANEOUSLY AS
IT WILL CAUSE THE DRAWER
CHEST TO FALL DOWN.

WALL

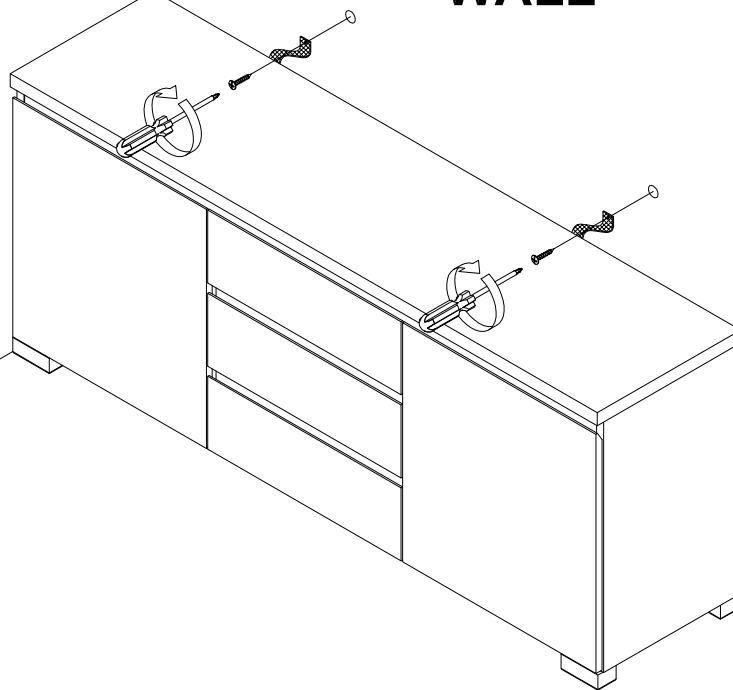

WARNING :

ENSURE THAT WALL STRAP IS ATTACHED TO AVOID SERIOUS INJURY

To avoid any serious injury, this product has been supplied with a wall strap to prevent toppling.

We strongly recommend that this product is permanently fixed to the wall or other suitable surface.

Wall fixing hardware is not supplied as different surface materials require different attachments. Please seek professional advice if you are in doubt of what fixing should be use.

Wall fixings can be purchased from your local hardware store.



MEUBILAIR
DIRECT IMPORTS

Warranty Certificate

Congratulations! You have made an excellent choice of this quality product. Our commitment to quality also includes our service. Should you, contrary to expectations, experience defects due to manufacturing faults, **Meubilair Direct Imports** will provide you with a warranty against defects as follows:

Warranty

The product is guaranteed to be free from defects in workmanship and parts for a period of 12 months from the date of purchase. Defects that occur within this warranty period, under normal use and care, will be repaired, replaced or refunded at our discretion. The benefits conferred

by this warranty are in addition to all rights and remedies in respect of the product that the consumer has under the Competition and

Consumer Act 2010 and similar state and territory laws.

Our goods come with guarantees that cannot be excluded under the Australian Consumer Law. You are entitled to a replacement or refund for a major failure and for compensation for any other reasonably foreseeable loss or damage. You are also entitled to have the goods repaired or replaced if the goods fail to be of acceptable quality and the failure does not amount to a major failure.

Proof of Purchase

This warranty is valid for the original purchase and is not transferable. Please keep your purchase docket, tax invoice or receipt as the best proof of purchase, and as proof of date on which the purchase was made.

Normal Wear and Tear

This warranty does not cover normal wear and tear to the products or parts.

Exclusions

This warranty does not cover:

- Any defects caused by an accident, misuse, abuse, improper installation or operation, lack of reasonable care, unauthorized modification, loss of parts, tampering or attempted repair by a person not authorized by the distributor.
- Any product that has not been installed, operated or maintained in accordance with the manufacturers' operating instructions provided with the product.
- Any product that has been used for purposes other than domestic use.
- Any damage caused by improper power input or improper cable connection.

MEUBILAIR DIRECT IMPORTS PTY LTD

Customer Service

Email: cs@meubilair.com.au

Address: Unit 4, 4-5 Lambridge Place, Penrith, NSW, 2750

Opening Hours 9:00 am - 4:30pm (Mon-Fri)

When making a return, please ensure the product is properly packaged, so as to ensure that no damage occurs to the product during transit.

Please provide the original or a copy of the proof of purchase. Also please make sure you have included an explanation of the problem.

Please note that the costs of making a warranty claim, including any return postage, will be covered by the supplier identified above.

Please note upon receiving your warranty claim, the supplier will send, via the post or email, a repair and refurbished goods or parts notice.

Please provide your email address and advise the supplier, if you wish to obtain a repair and refurbished goods or parts notice via email.

AFTER SALES SUPPORT

EMAIL : cs@meubilair.com.au

Product code: 5250R-WHT

10/2020





MEUBILAIR
DIRECT IMPORTS

Warranty Certificate

PRODUCT NAME **ELARA LARGE SIDEBOARD**

BRAND NAME

PRODUCT CODE 5250R-WHT

NAME

ADDRESS

EMAIL

DAYTIME TEL NO

DATE OF PURCHASE

SERIAL NUMBER

We recommend that you attach a photocopy of your receipt, showing the date of purchase, to this Warranty certificate and **keep for your reference**.

In the event of a product fault, please email the Customer Service team. Please ensure that you include the product details (as shown on the card) at hand so that we are able to respond as quickly and efficiently as possible.

MEUBILAIR DIRECT IMPORTS PTY LTD

Customer Service

Email: cs@meubilair.com.au

Address: Unit 4, 4-5 Lambridge Place, Penrith, NSW, 2750

Opening Hours 9:00 am - 4:30pm (Mon-Fri)

Phone Number: +61 2 47015363

AFTER SALES SUPPORT

Product code: 5250R-WHT

10/2020

