

ASSEMBLY INSTRUCTIONS

PAGE: 1/10

MODEL : MFC 7915 OAK

Before you begin, please follow assembly instructions carefully, then follow them step by step.

Read instruction carefully . See Furniture Parts list and Hardware List for guidance . Be sure you have all parts before you start assembling . Place and assemble furniture on a clean flat soft surface , such as carpet or rug to prevent being scratched .

PART LIST		QTY
1	TOP PANEL	1 PC
2	BOTTOM PANEL	1 PC
3	SIDE PANEL (L)	1 PC
4	SIDE PANEL (R)	1 PC
5	CENTER PANEL (L)	1 PC
6	CENTER PANEL (R)	1 PC
7	MIDDLE PANEL	2 PCS
8	DOOR PANEL	2 PCS
9	SHELF PANEL	2 PCS
10	BACK PANEL	1 PC
11	DRAWER FRONT	3 PCS
12	DRAWER SIDE	6 PCS
13	DRAWER BACK	3 PCS
14	DRAWER BOTTOM	3 PCS
15	LEG	4 PCS

HARDWARE				
A	MINI FIX	A1 A2 A3		12 PCS
B	M8 X 30MM WOOD DOWEL			20 PCS
C	M6 X 50MM CSK CAP WOOD SCREW			8 PCS
D	M4 X 38MM C.B SCREW			24 PCS
E	M3.5 X 16MM C.B SCREW			52 PCS
F	METAL SHELF SUPPORT			8 PCS
G	ALLEN KEY M4			1 PC
H	5/8 NAIL			70 PCS
I	14" DRAWER SLIDE		I1 (L/R) I2 (L/R)	3 SETS
J	7/8 HINGES			4 SETS
K	HANDLE 0161-128			5 PCS
L	HANDLE SCREW M4 x 19MM			10 PCS
M	JCBC SCREW M6 x 70			8 PCS
N	SPRING WASHER M6			8 PCS
O	FLAT WASHER M6			8 PCS
P	TIPPING PACK		P1 P2 P3 P4 P5	2 SETS

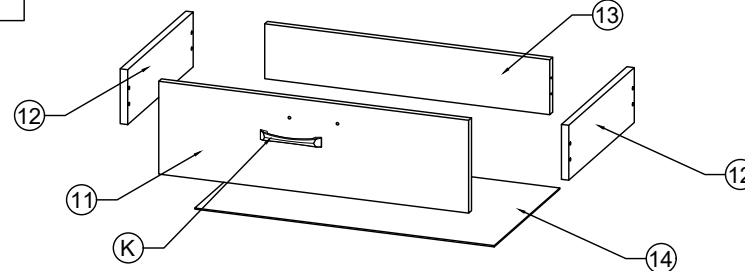
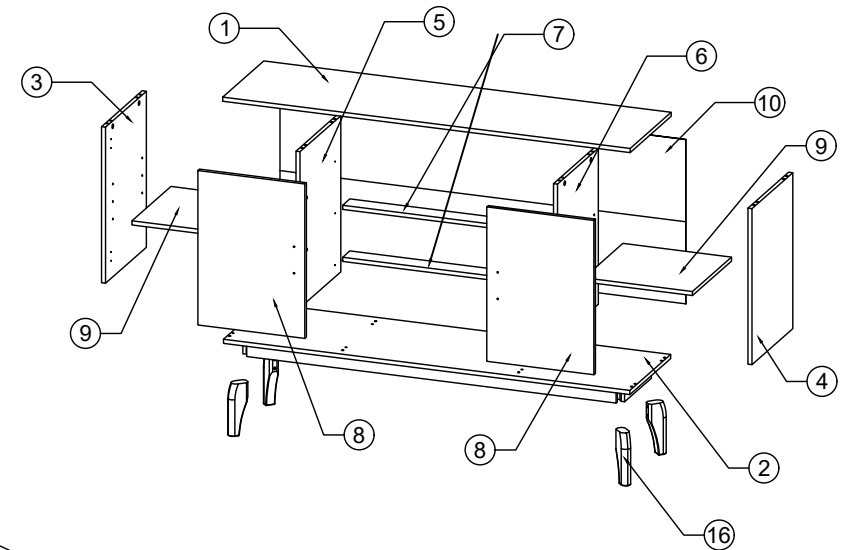
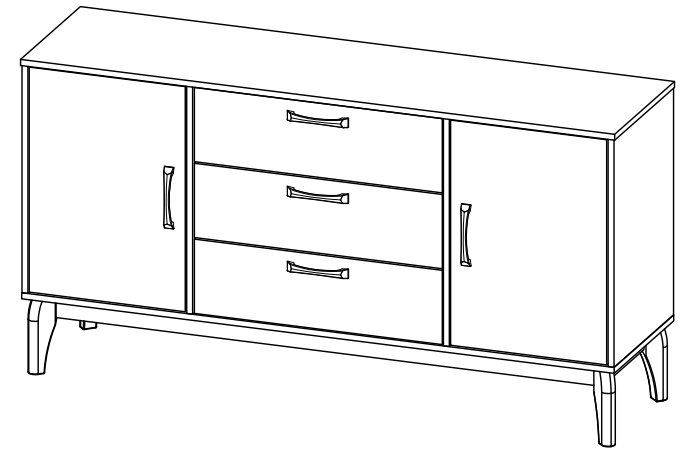

SELF-PREPARED TOOLS: Tools below are NOT included in package.



SCREWDRIVER



HAMMER



POWER DRILL

Reminder:

Please ensure that all surfaces and edges with colours/laminations are facing forward/outward.

ASSEMBLY INSTRUCTIONS

MODEL : MFC 7915 OAK

STEP 1

Insert hardware **A2** onto panel **(1)**.
(Repeat 8 times.)

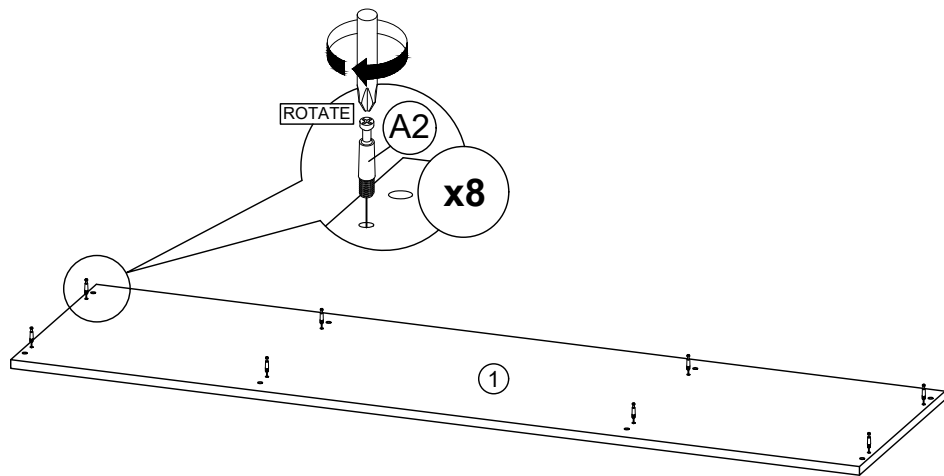

STEP 2

- Insert hardware **A1** onto panel **(3)**.
(Repeat 2 times.)
- Insert hardware **B** onto panel **(3)**.
(Repeat 4 times.)

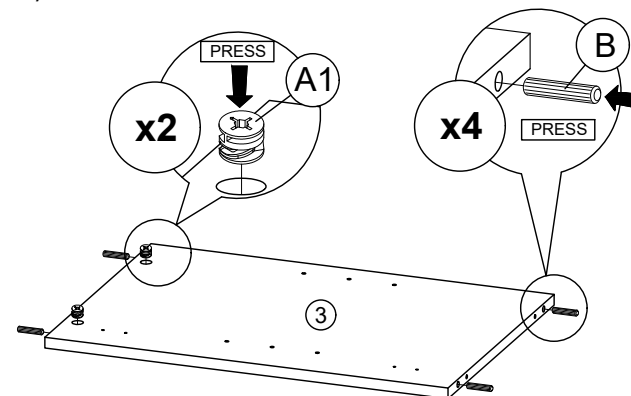

* Ensure the arrows on hardware **A1** point towards mounting positions.

STEP 3

- Insert hardware **A1** onto panel **(4)**.
(Repeat 2 times.)
- Insert hardware **B** onto panel **(4)**.
(Repeat 4 times.)

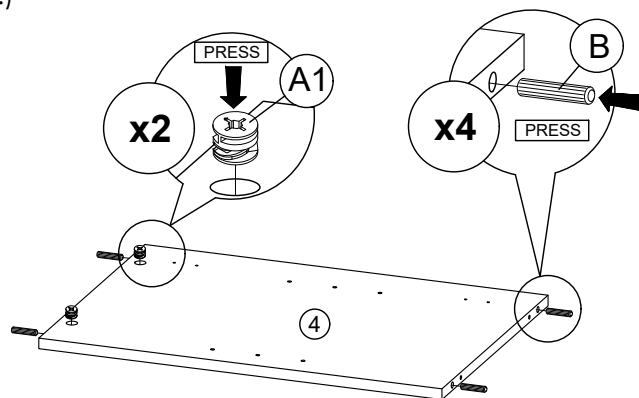

* Ensure the arrows on hardware **A1** point towards mounting positions.

STEP 4

- Insert hardware **A1** onto panel **(5)**.
(Repeat 2 times.)
- Insert hardware **B** onto panel **(5)**.
(Repeat 4 times.)

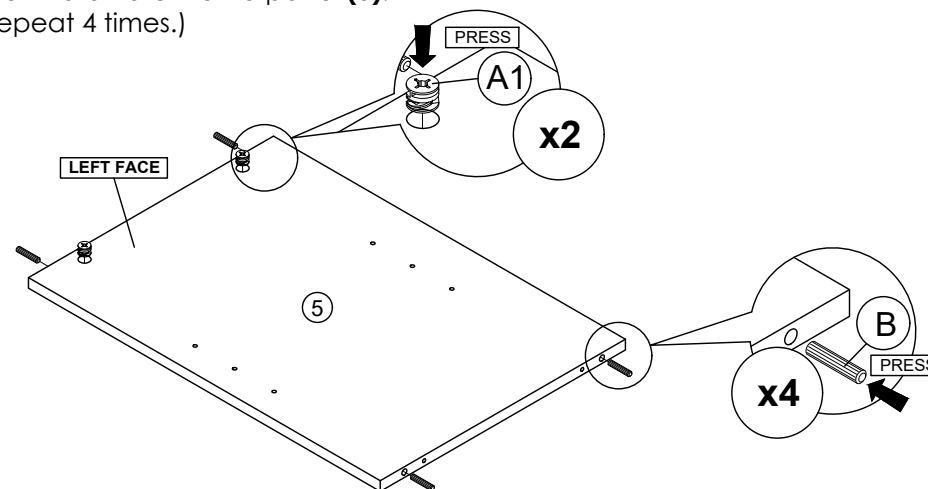

* Ensure the arrows on hardware **A1** point towards mounting positions.

ASSEMBLY INSTRUCTIONS

PAGE: 3/10

MODEL : MFC 7915 OAK

STEP 5

Insert hardware **A2** onto panel **(5)**.
(Repeat 2 times.)

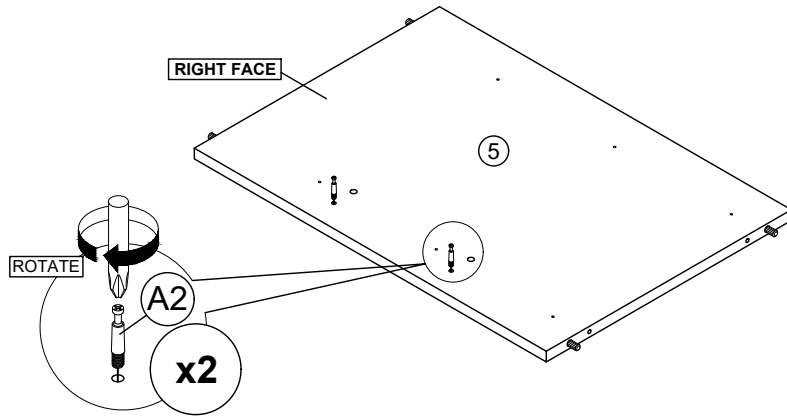

STEP 6

- Fix hardware **I1 (L)** into panel **(5)** with hardware **E**.
(Repeat 9 times.)

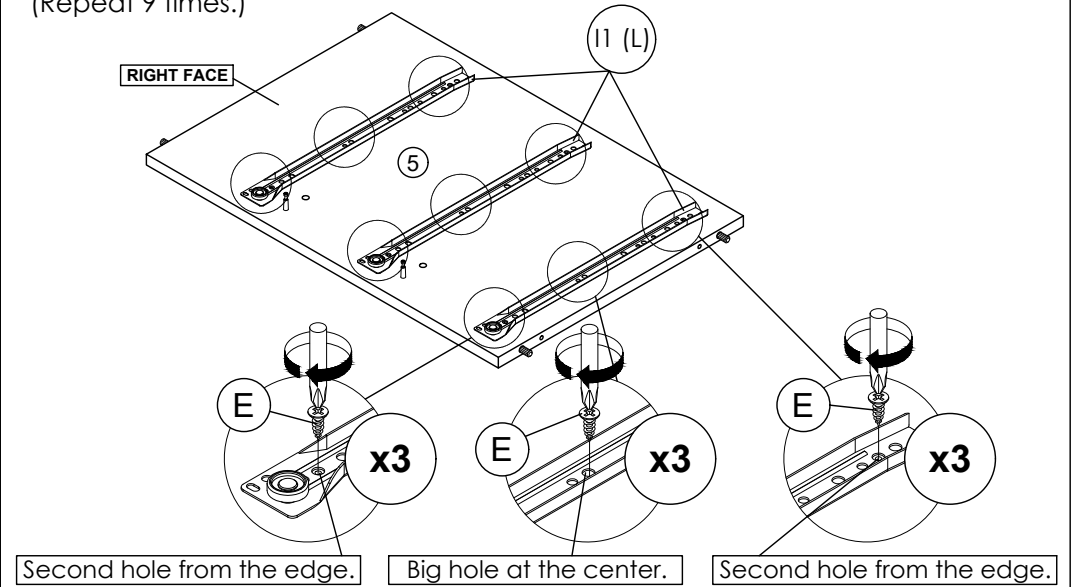

STEP 7

Insert hardware **A2** onto panel **(6)**.
(Repeat 2 times.)

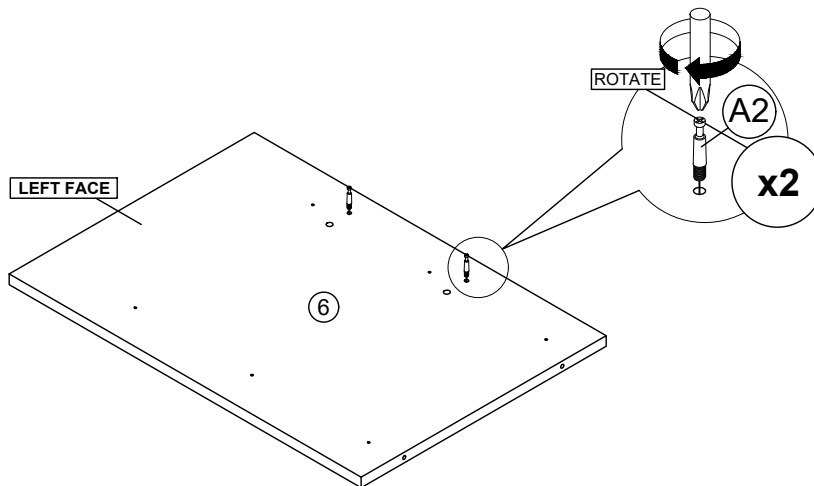

STEP 8

- Fix hardware **I1 (R)** into panel **(6)** with hardware **E**.
(Repeat 9 times.)

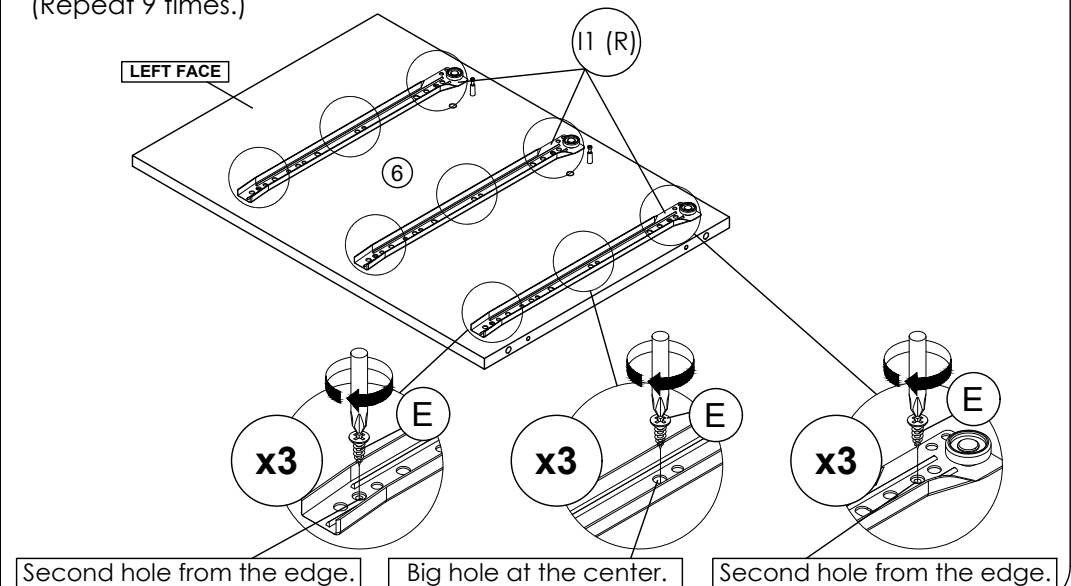
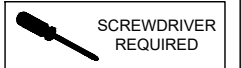

ASSEMBLY INSTRUCTIONS

MODEL : MFC 7915 OAK

STEP 9

- Insert hardware **A1** onto panel **(6)**.
(Repeat 2 times.)
- Insert hardware **B** onto panel **(6)**.
(Repeat 4 times.)

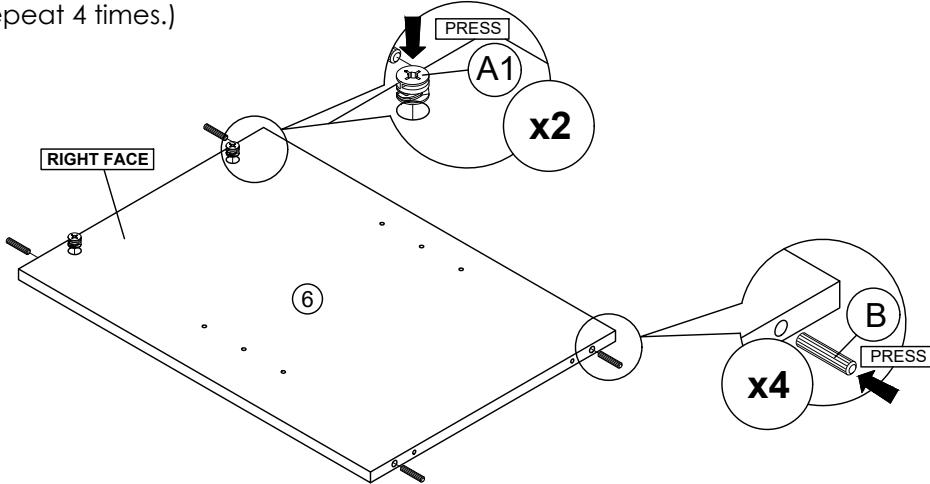

* Ensure the arrows on hardware **A1** point towards mounting positions.

STEP 10

- Insert hardware **A1** onto panel **(7)**.
(Repeat 4 times.)
- Insert hardware **B** onto panel **(7)**.
(Repeat 4 times.)

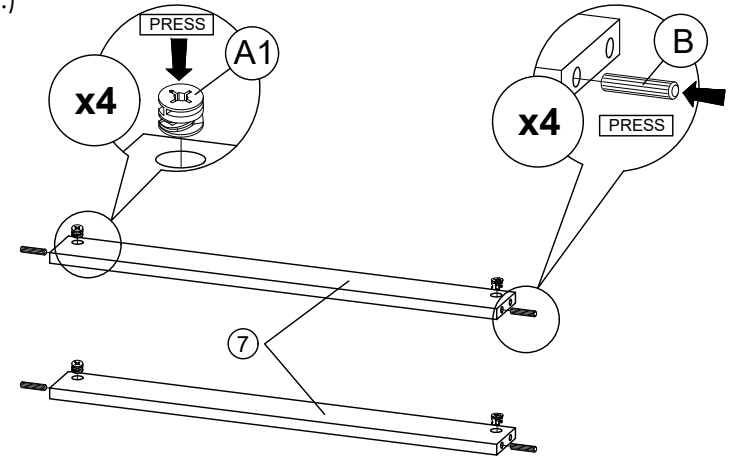

* Ensure the arrows on hardware **A1** point towards mounting positions.

STEP 11

- Attach panel **(5)** to panel **(7)**.
- Insert all hardware **A2** into **A1**.
- Rotate all **A1** until tight.
- Apply **A3** onto all **A1**.
(Repeat 2 times.)

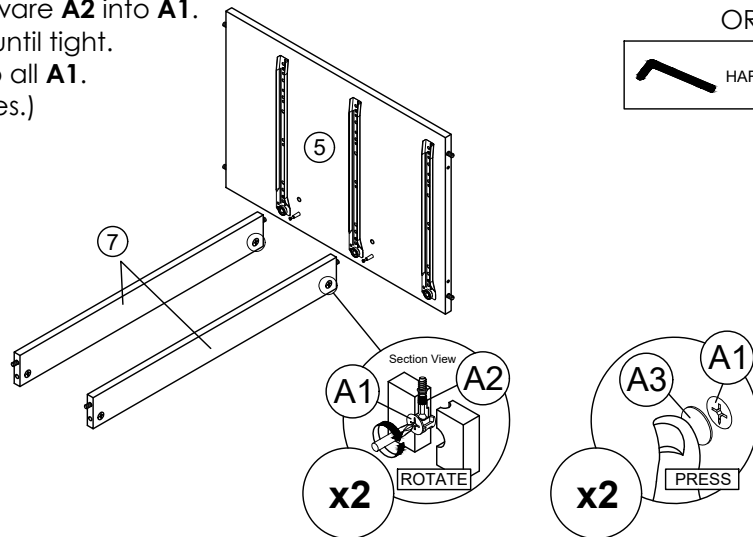

OR



* In this step hardware **A1**, **A2** and **B** are pre-inserted.

STEP 12

- Attach panel **(6)** to panel **(7)**.
- Insert all hardware **A2** into **A1**.
- Rotate all **A1** until tight.
- Apply **A3** onto all **A1**.
(Repeat 2 times.)

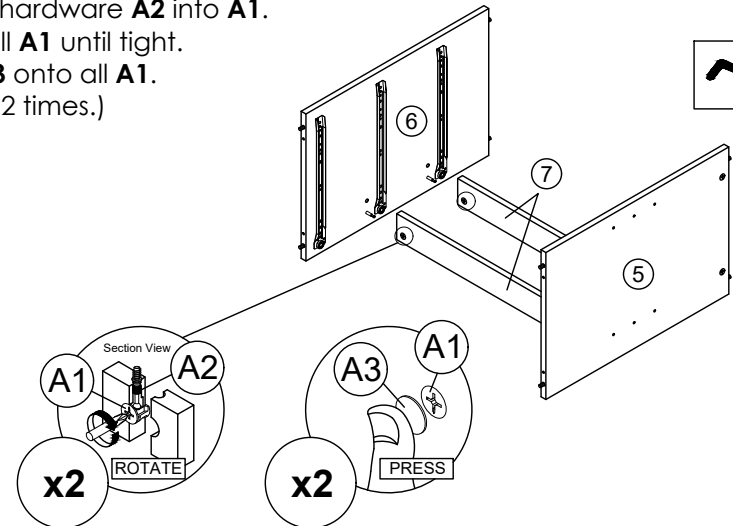

OR



* In this step hardware **A1**, **A2** and **B** are pre-inserted.

ASSEMBLY INSTRUCTIONS

PAGE: 5/10

MODEL : MFC 7915 OAK

STEP 13

- Attach panel (1) to panel (5) and (6).
 - Insert all hardware **A2** into **A1**.
 - Rotate all **A1** until tight.
 - Apply **A3** onto all **A1**.
- (Repeat 4 times.)

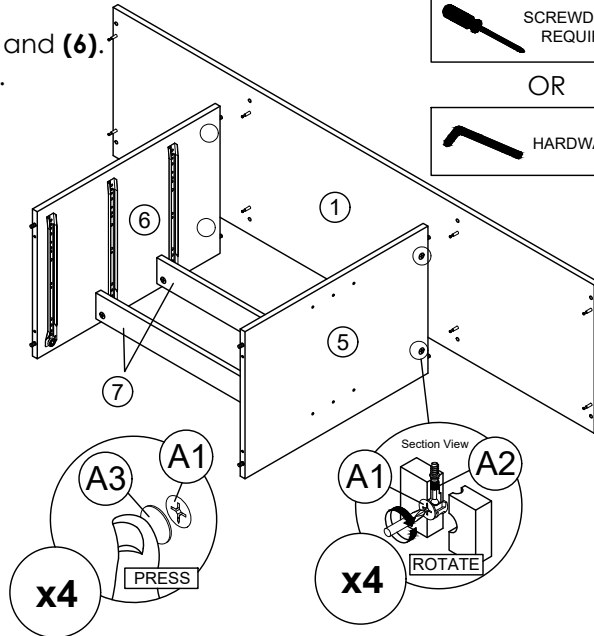
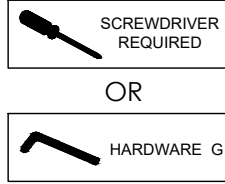

* In this step hardware **A1**, **A2** and **B** are pre-inserted.

STEP 14

- Attach panel (1) to panel (3).
 - Insert all hardware **A2** into **A1**.
 - Rotate all **A1** until tight.
 - Apply **A3** onto all **A1**.
- (Repeat 2 times.)

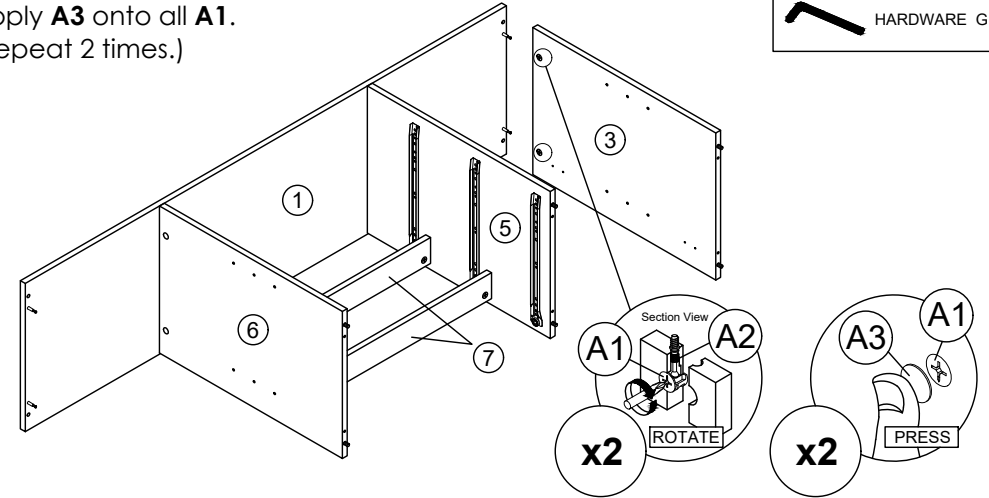
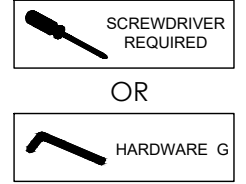

* In this step hardware **A1**, **A2** and **B** are pre-inserted.

STEP 15

- Attach panel (1) to panel (4).
 - Insert all hardware **A2** into **A1**.
 - Rotate all **A1** until tight.
 - Apply **A3** onto all **A1**.
- (Repeat 2 times.)

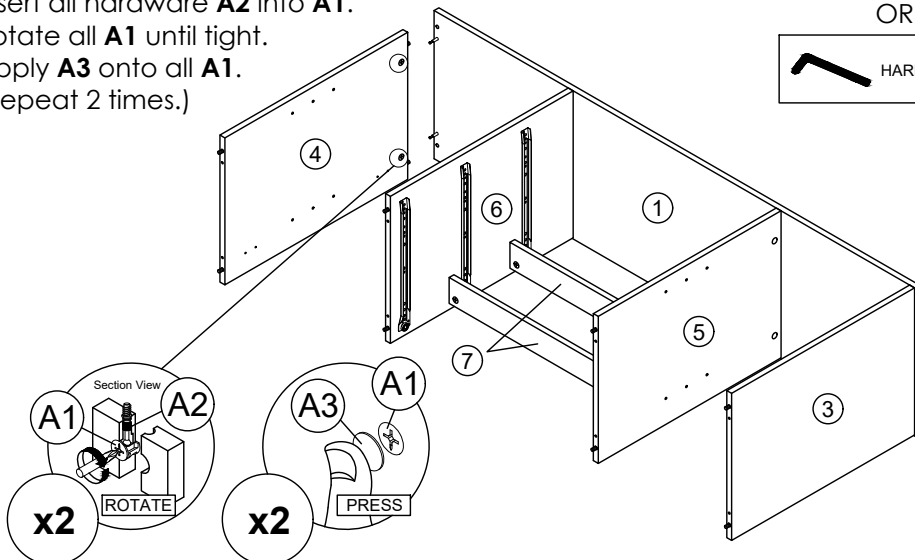
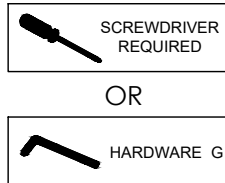

* In this step hardware **A1**, **A2** and **B** are pre-inserted.

STEP 16

- Connect panel (2) to panel (3), (4), (5) and (6) by using hardware **C** and **G**.
- (Repeat 8 times.)

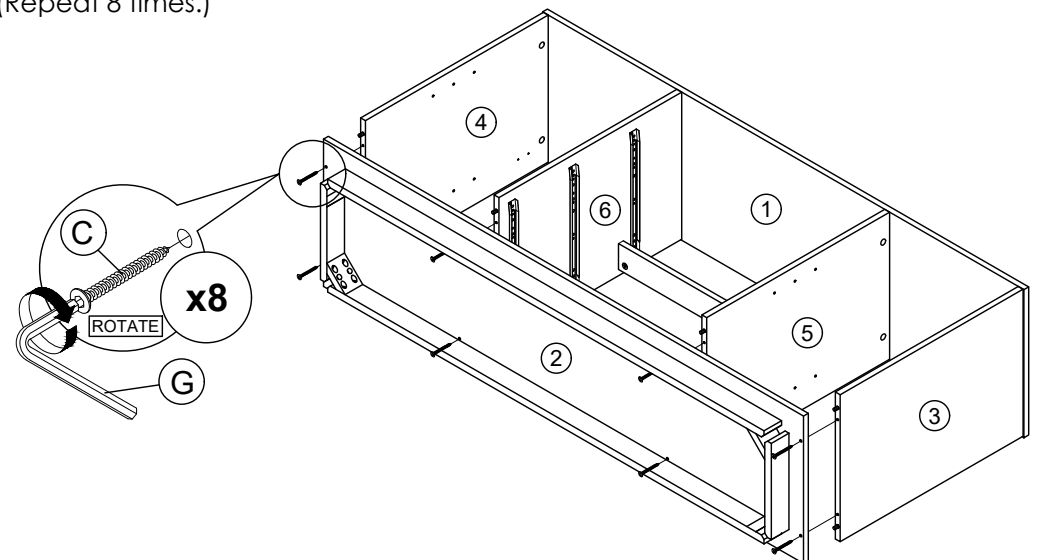

ASSEMBLY INSTRUCTIONS

PAGE: 6/10

MODEL : MFC 7915 OAK

STEP 17

Assemble part **16** into panel **(2)** by using hardware **G**, **M**, **N** and **O**.
(Repeat 8 times.)

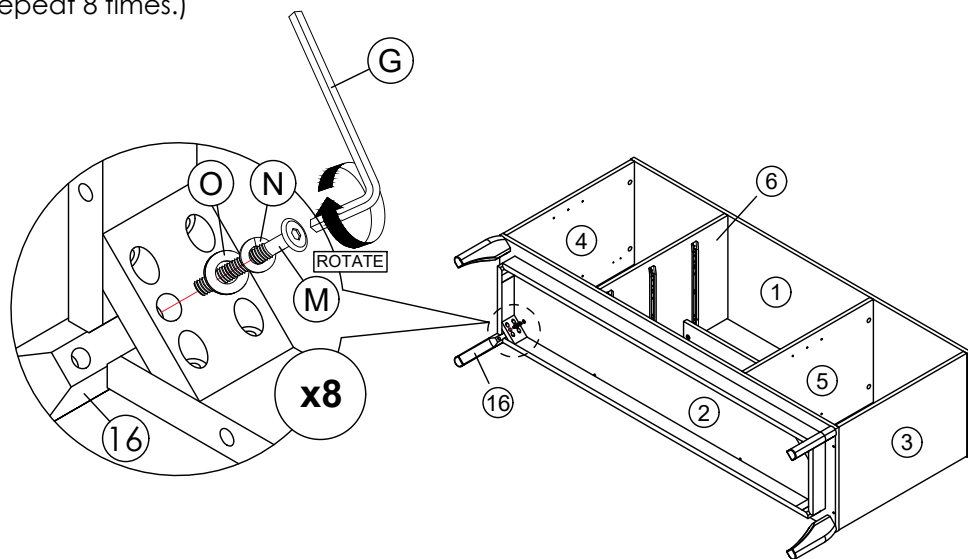

STEP 18

Assemble panel **(10)** to entire drawer by using hardware **H**.
(Repeat 40 times.)

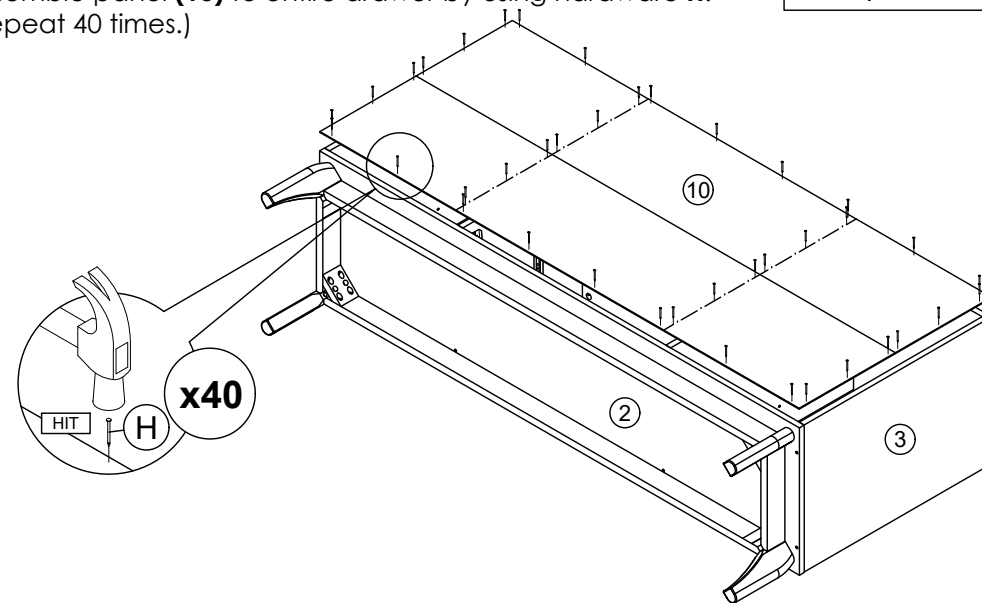

STEP 19

Fix hardware **F** into panel **(3)**, **(4)**, **(5)** and **(6)**.
(Repeat 8 times.)

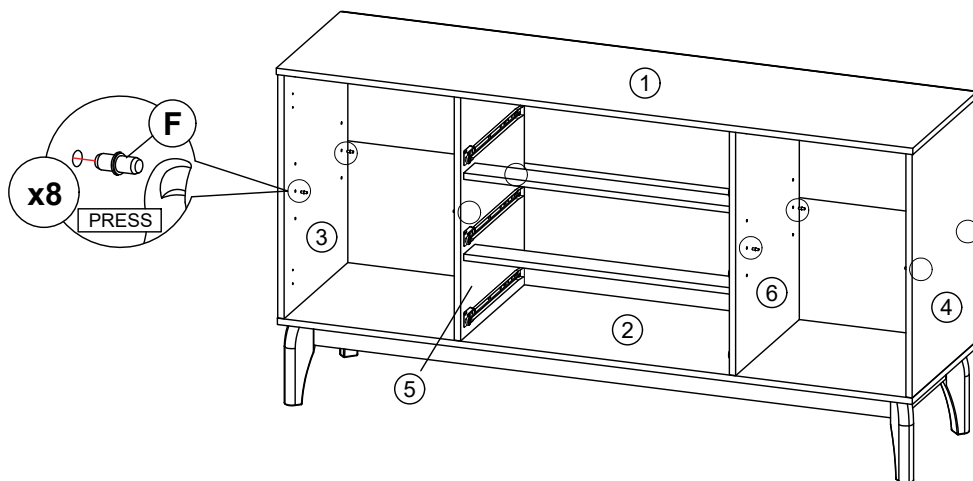

STEP 20

Assemble the panel **(9)** into between panel **(3)**, **(4)**, **(5)** and **(6)**.
(Repeat 2 times.)

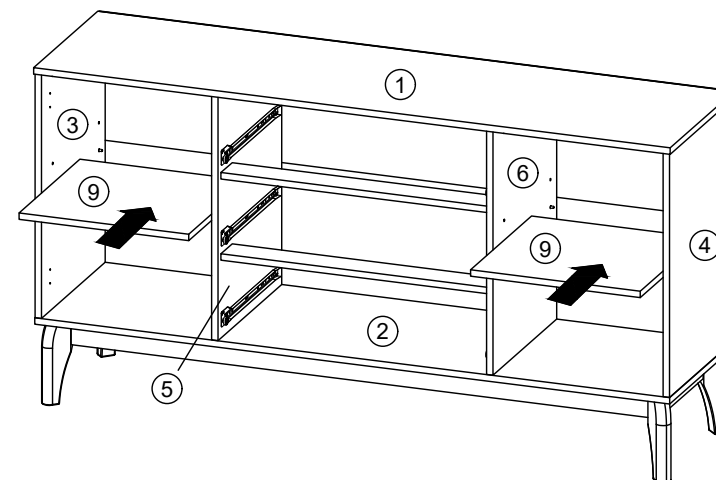

ASSEMBLY INSTRUCTIONS

PAGE: 7/10

MODEL : MFC 7915 OAK

STEP 21

Fix hardware **J** onto panel **(8)** by using hardware **E**.
(Repeat 8 times.)

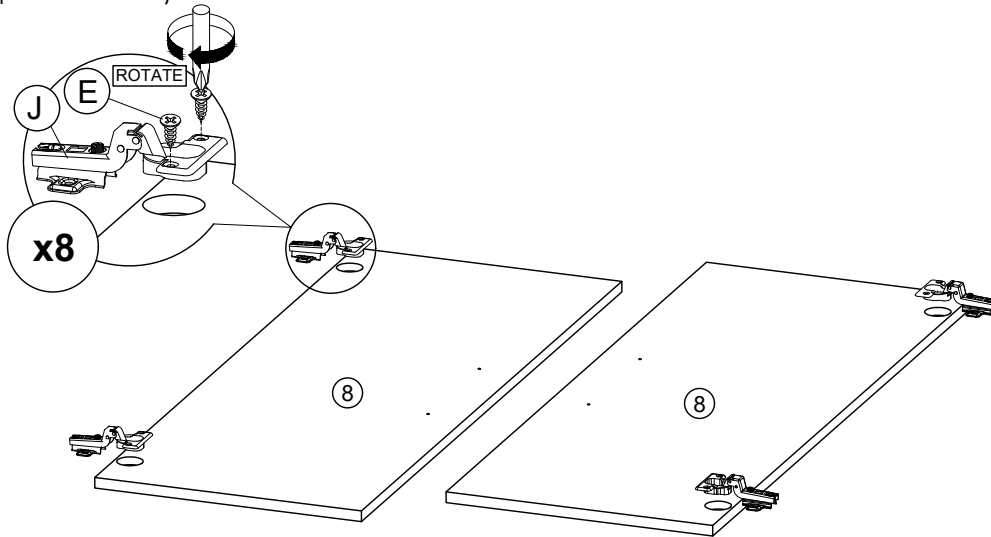

STEP 22

Fix hardware **K** onto panel **(8)** by using hardware **L**.
(Repeat 4 times.)

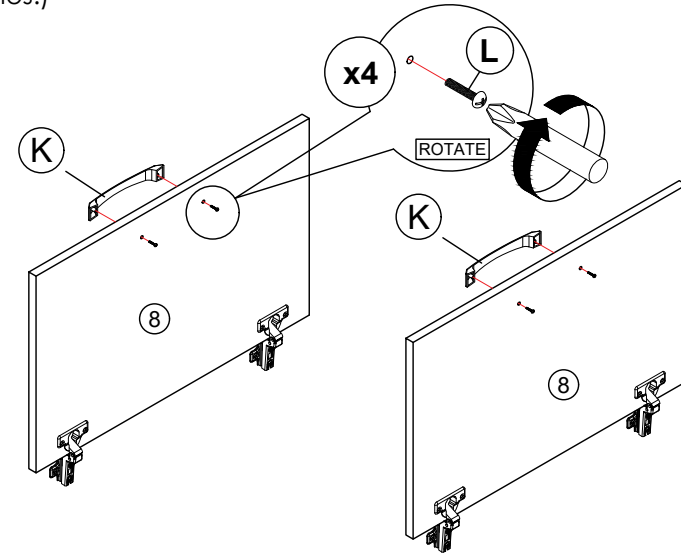

STEP 23

- Fix hardware **J** into panel **(3)** and **(8)** by using hardware **E**.
(Repeat 2 times.)
- Tighten or loosen the screw to adjust position of panel **(8)**.
(Do only when needed.)

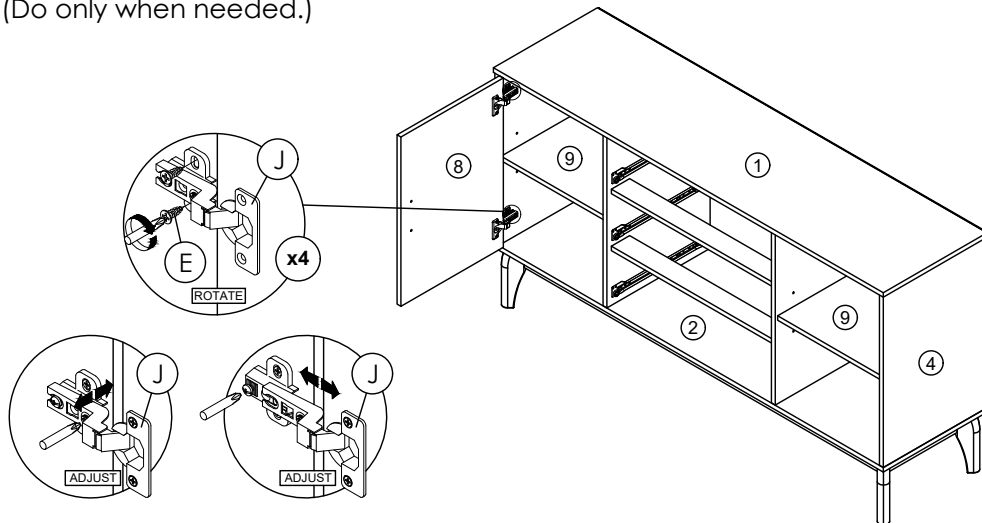

STEP 24

- Fix hardware **J** into panel **(4)** and **(8)** by using hardware **E**.
(Repeat 2 times.)
- Tighten or loosen the screw to adjust position of panel **(8)**.
(Do only when needed.)

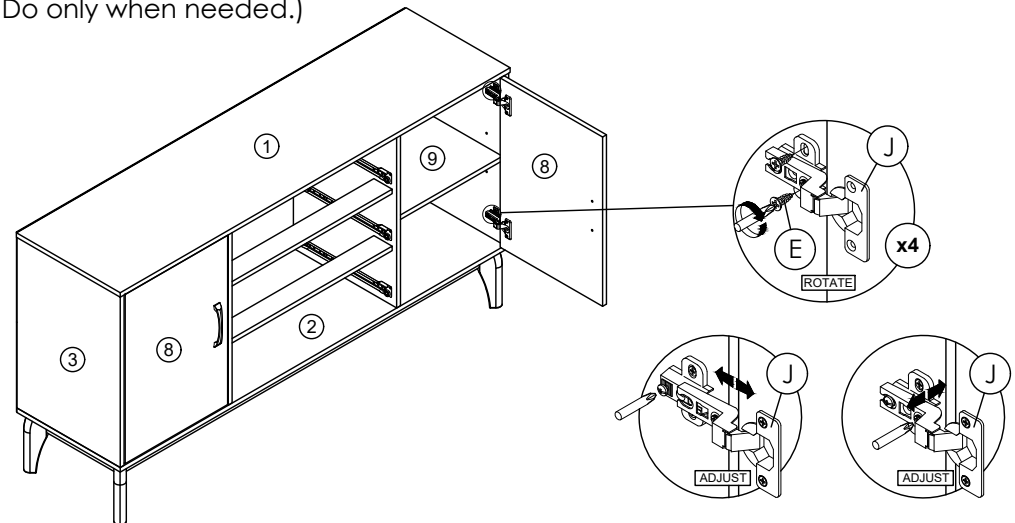

ASSEMBLY INSTRUCTIONS

MODEL : MFC 7915 OAK

STEP 25

Assemble panel (12) with panel (11) and (13) by using hardware D. (Repeat 24 times.)

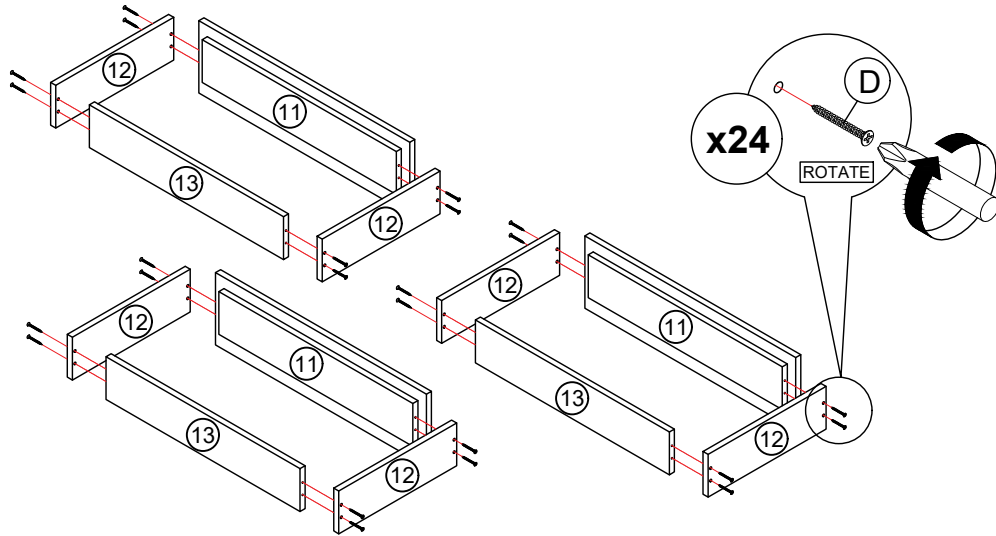

STEP 26

Assemble panel (14) to entire drawer by using hardware H. (Repeat 30 times.)

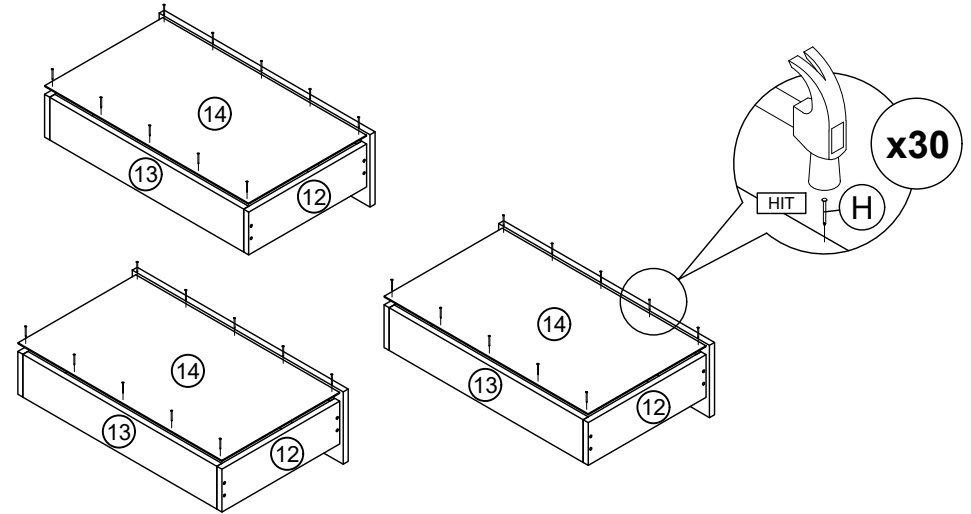

STEP 27

Assemble hardware I2 (L) to panel (14) by using hardware E. (Repeat 9 times.)

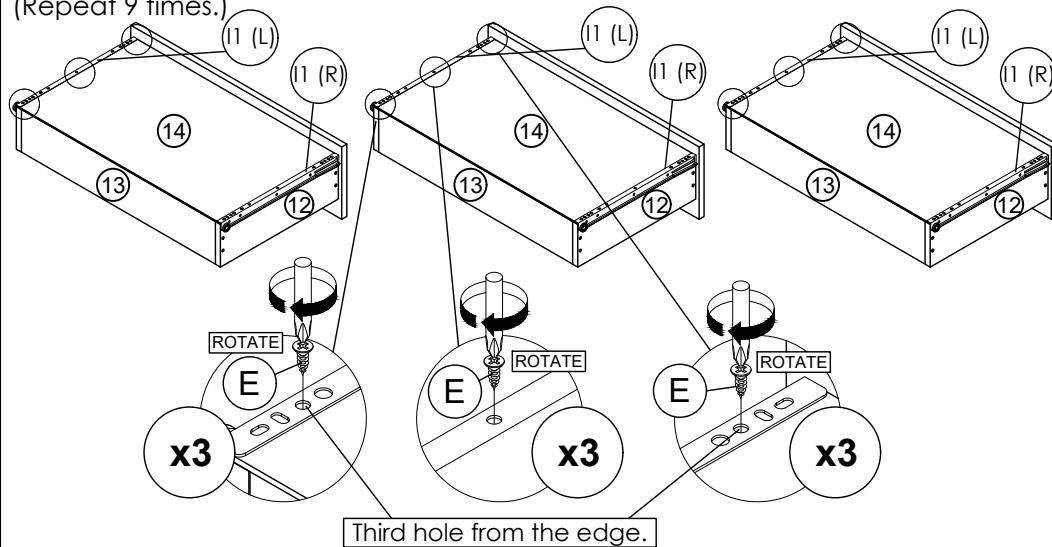

*Hardware I2 L shall be leaning against panel (11) when assembling.

STEP 28

Assemble hardware I2 (R) to panel (14) by using hardware E. (Repeat 9 times.)

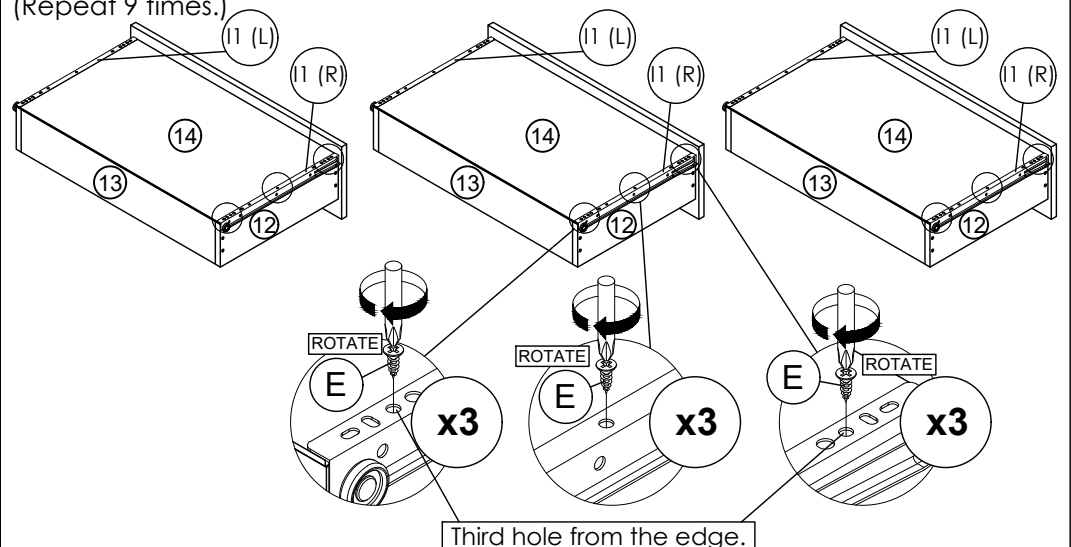

*Hardware I2 R shall be leaning against panel (11) when assembling.

ASSEMBLY INSTRUCTIONS

MODEL : MFC 7915 OAK

STEP 29

Fix hardware **K** onto panel **(11)** by using hardware **L**.
(Repeat 6 times.)

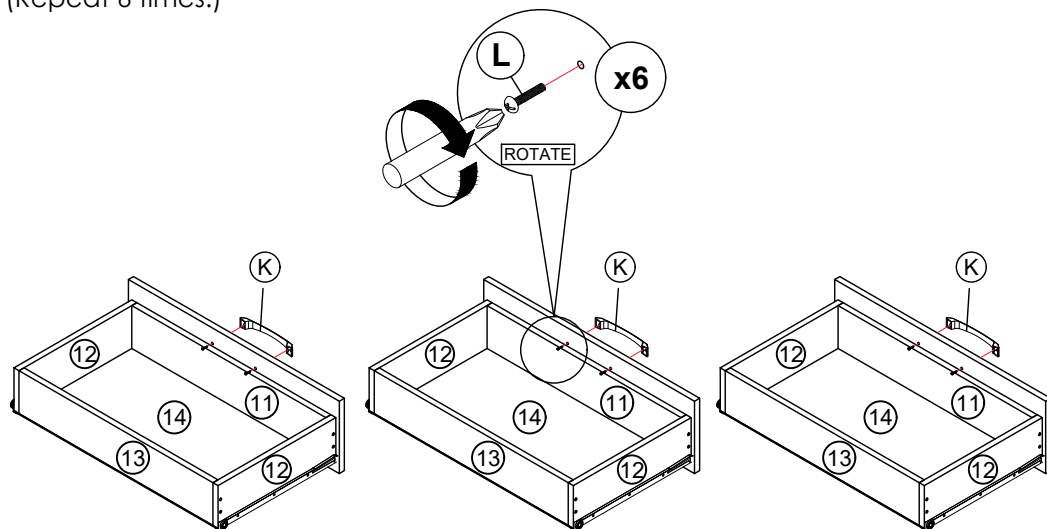

STEP 30

Put the drawer in place along the drawer slides.

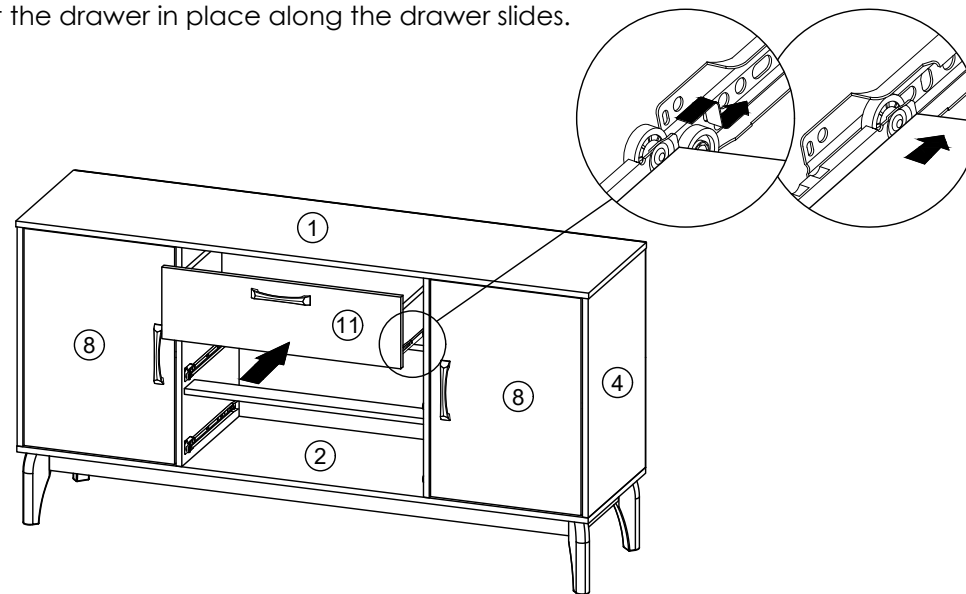

STEP 31

Put the drawer in place along the drawer slides.

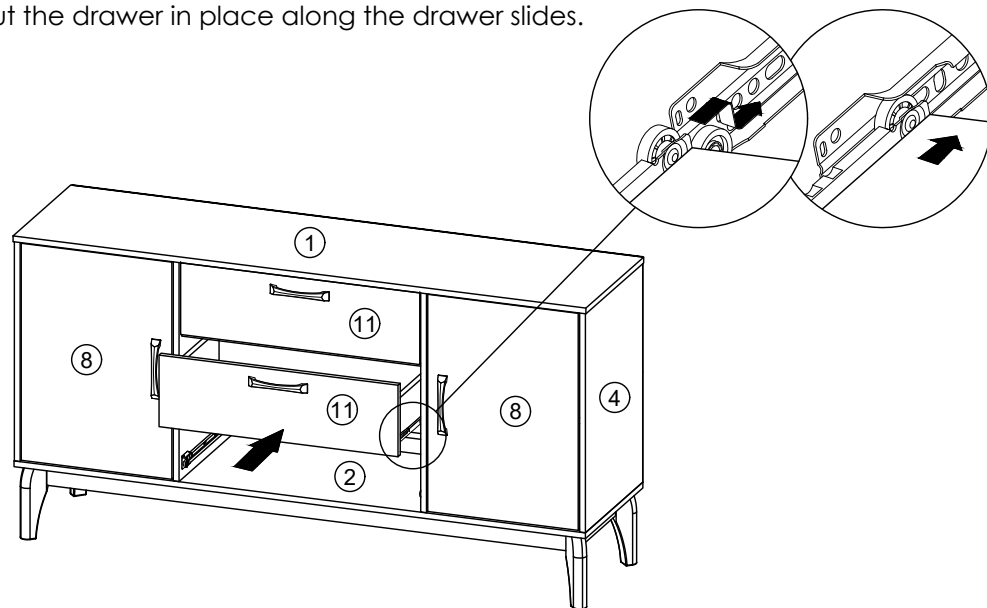

STEP 32

Put the drawer in place along the drawer slides.

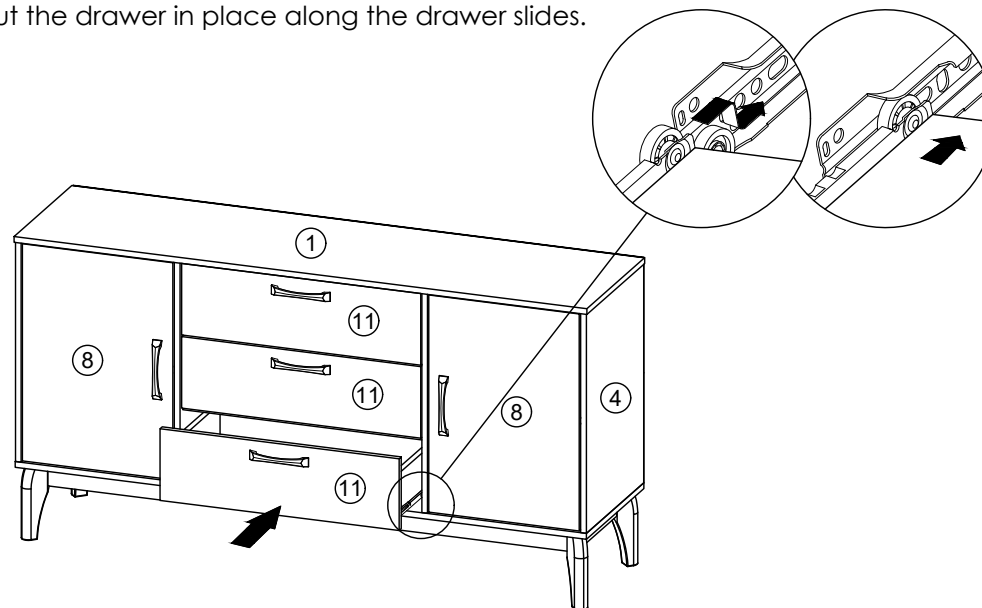

ASSEMBLY INSTRUCTIONS

MODEL : MFC 7915 OAK

STEP 33

Assemble hardware **P1** into panel **(1)** and **(10)** by using hardware **P2**.
(Repeat 2 times.)

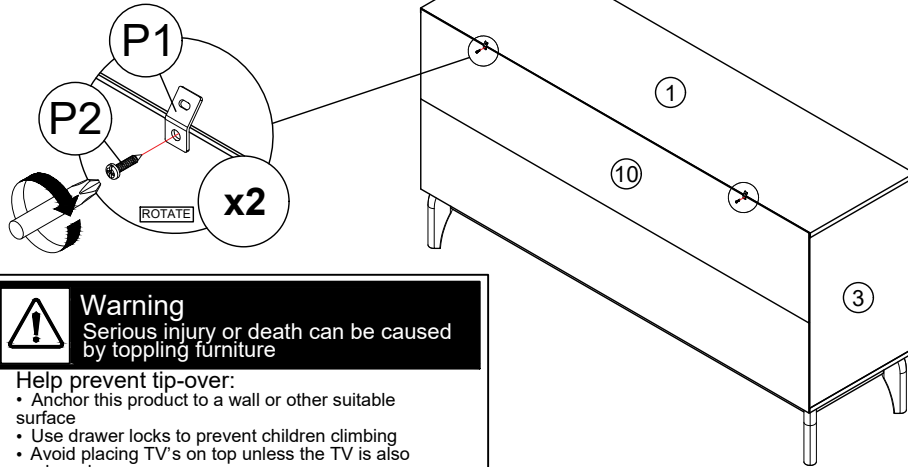

Warning
Serious injury or death can be caused by toppling furniture

Help prevent tip-over:

- Anchor this product to a wall or other suitable surface
- Use drawer locks to prevent children climbing
- Avoid placing TV's on top unless the TV is also anchored
- Check anchors regularly

STEP 34

- Mark and use the power drill to drill a hole on the wall.
- Hit hardware **P3** into the wall.
(Repeat 2 times.)

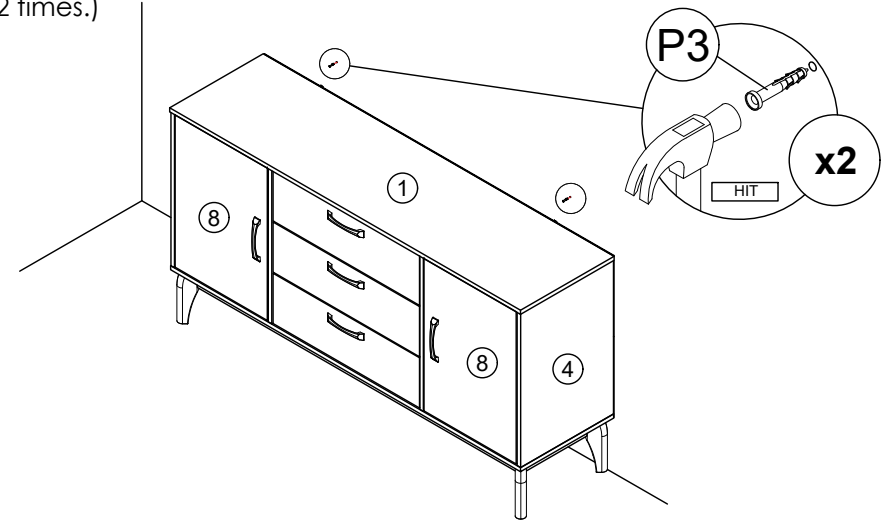

STEP 35

- Assemble hardware **P1** to **P3** by using hardware **P4**.
(Repeat 2 times.)

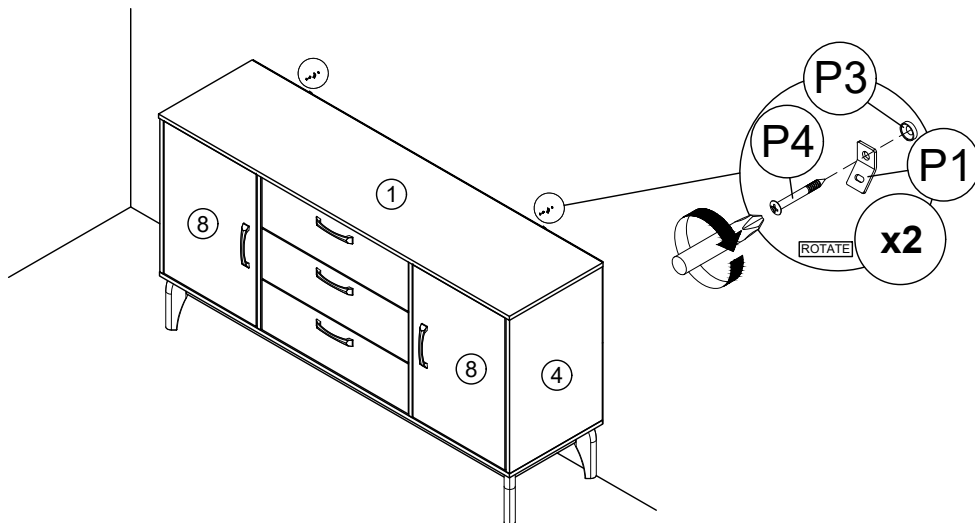

STEP 36

- Connect two of the hardware **P1** by using hardware **P5**.
- Tighten the hardware **P5**.
(Repeat 2 times.)

