

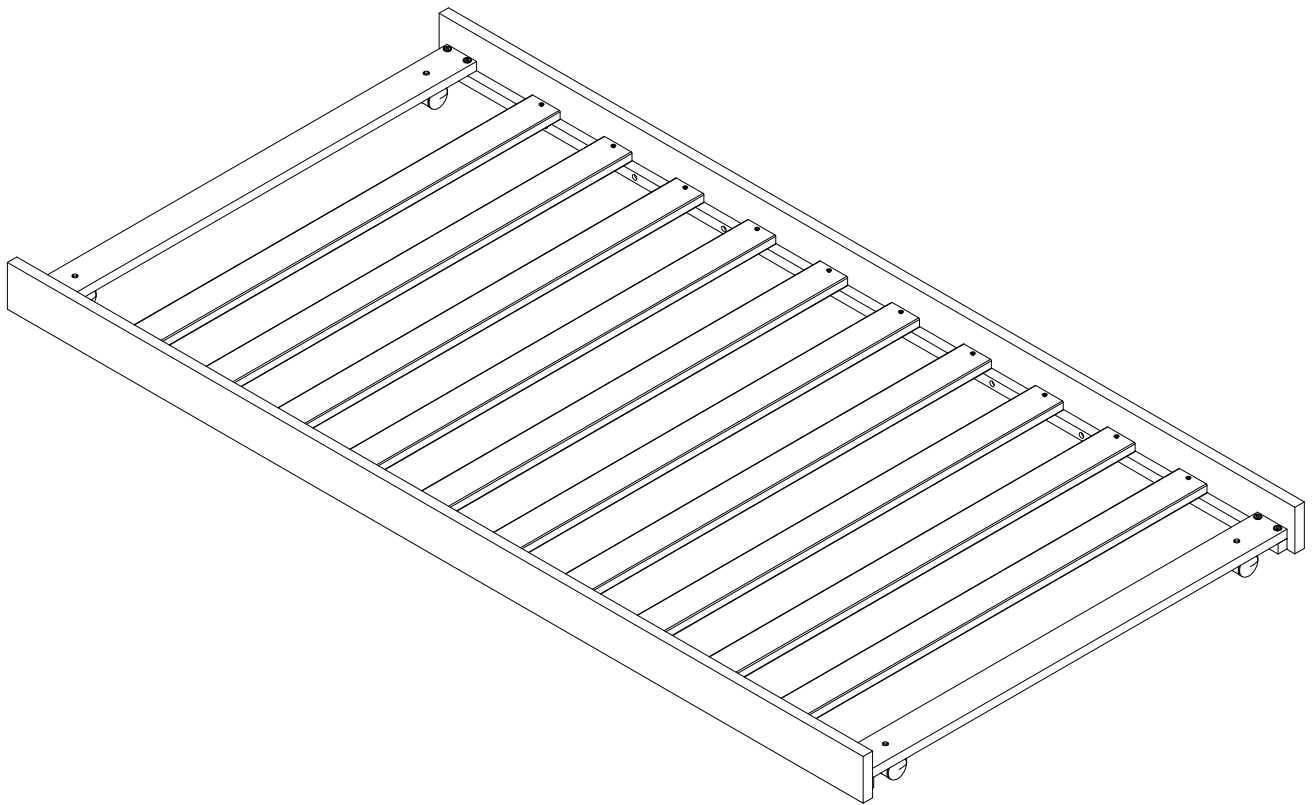

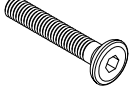

# ASSEMBLY INSTRUCTION

MODEL : WS 328W FREMANTLE TRUNDLE BED (930 x 1905)MM

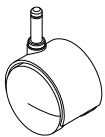
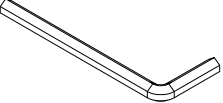

## HARDWARE LIST

<p><b>A</b> <span style="float: right;"><b>8 PCS</b></span></p>  <p>JCBC BOLT (M6 x 35MM)</p>	<p><b>B</b> <span style="float: right;"><b>20 PCS</b></span></p>  <p>CSK C/B SCREW (M4 x 32MM)</p>	<p><b>C</b> <span style="float: right;"><b>4 PCS</b></span></p>  <p>BLACK SOCKET</p>
<p><b>D</b> <span style="float: right;"><b>4 PCS</b></span></p>  <p>CASTOR 40SA</p>	<p><b>E</b> <span style="float: right;"><b>1 PC</b></span></p>  <p>ALLEN KEY (M4 x 60MM)</p>	 <p><i>Do not recommend the use of power drills/drivers for inserting bolts/screws as this could damage the unit.</i></p> <p><b>Tools Required :</b> Crosshead Screw Driver</p>

## PARTS LIST

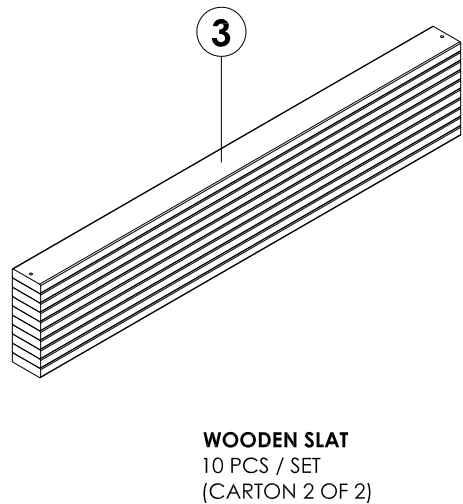
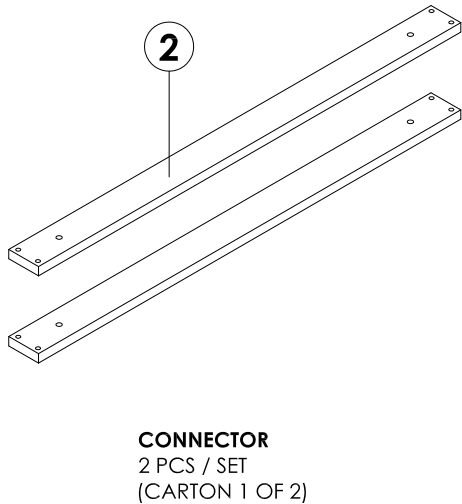
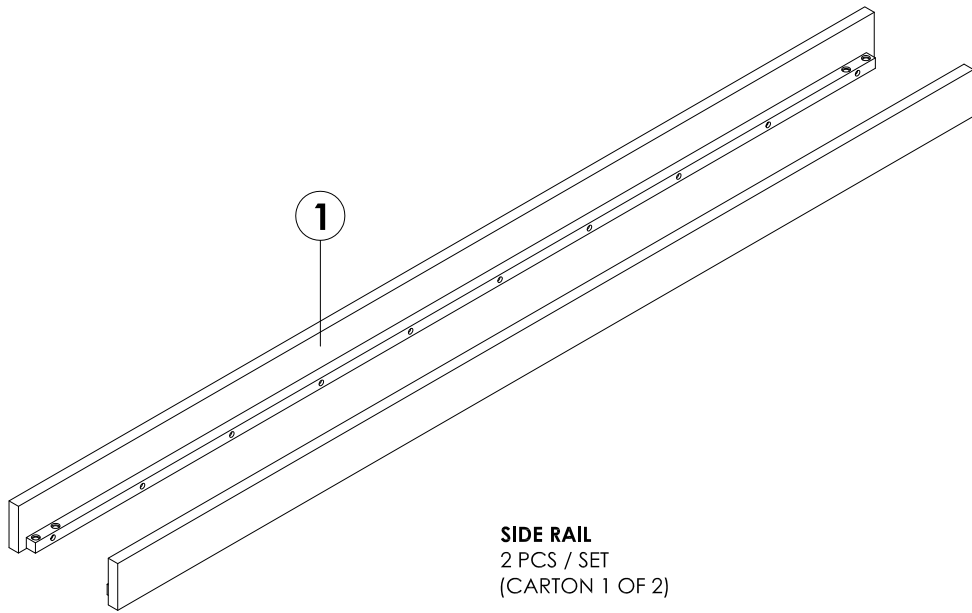

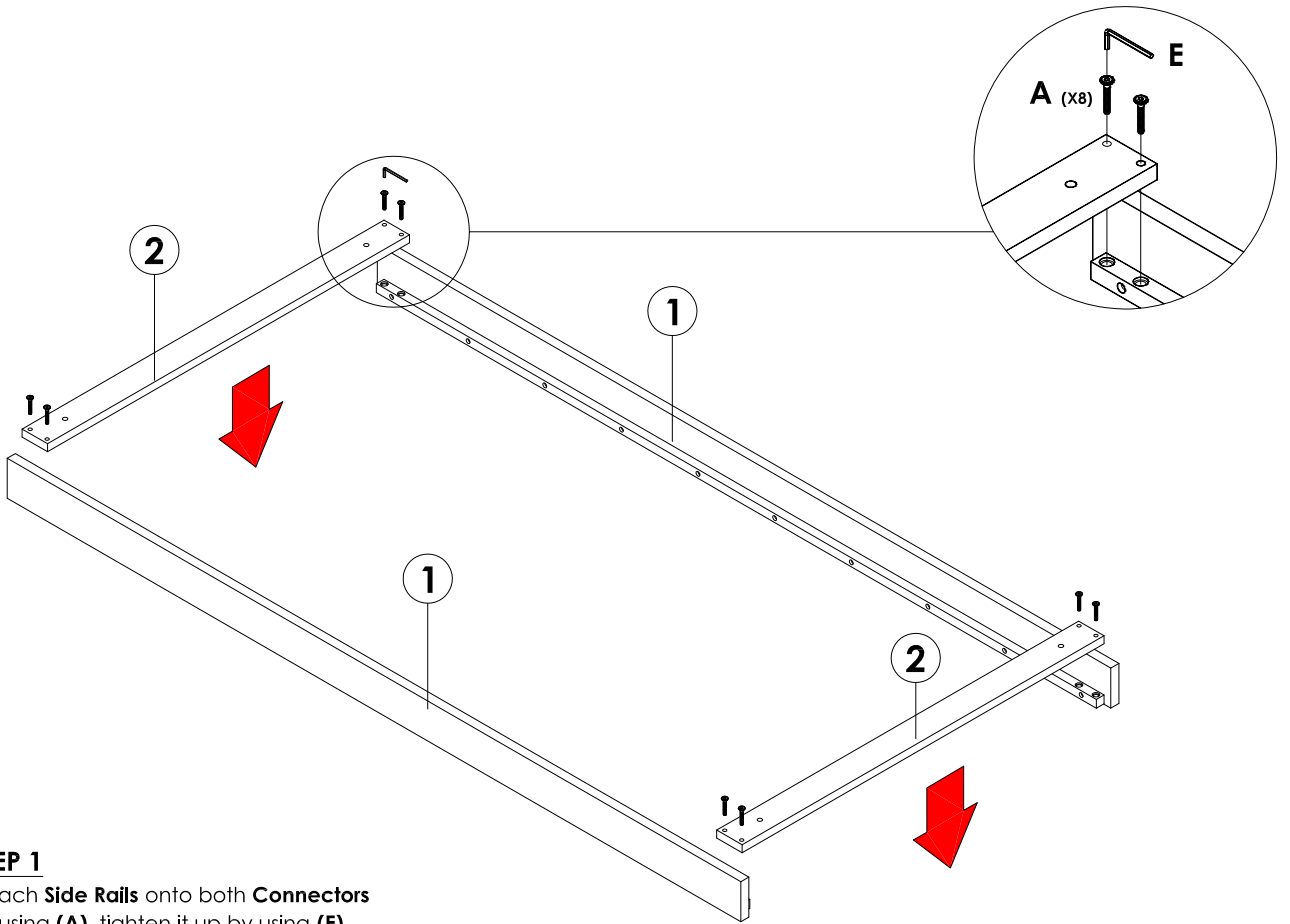

**STEP 1**

Attach **Side Rails** onto both **Connectors** by using **(A)**, tighten it up by using **(E)**.

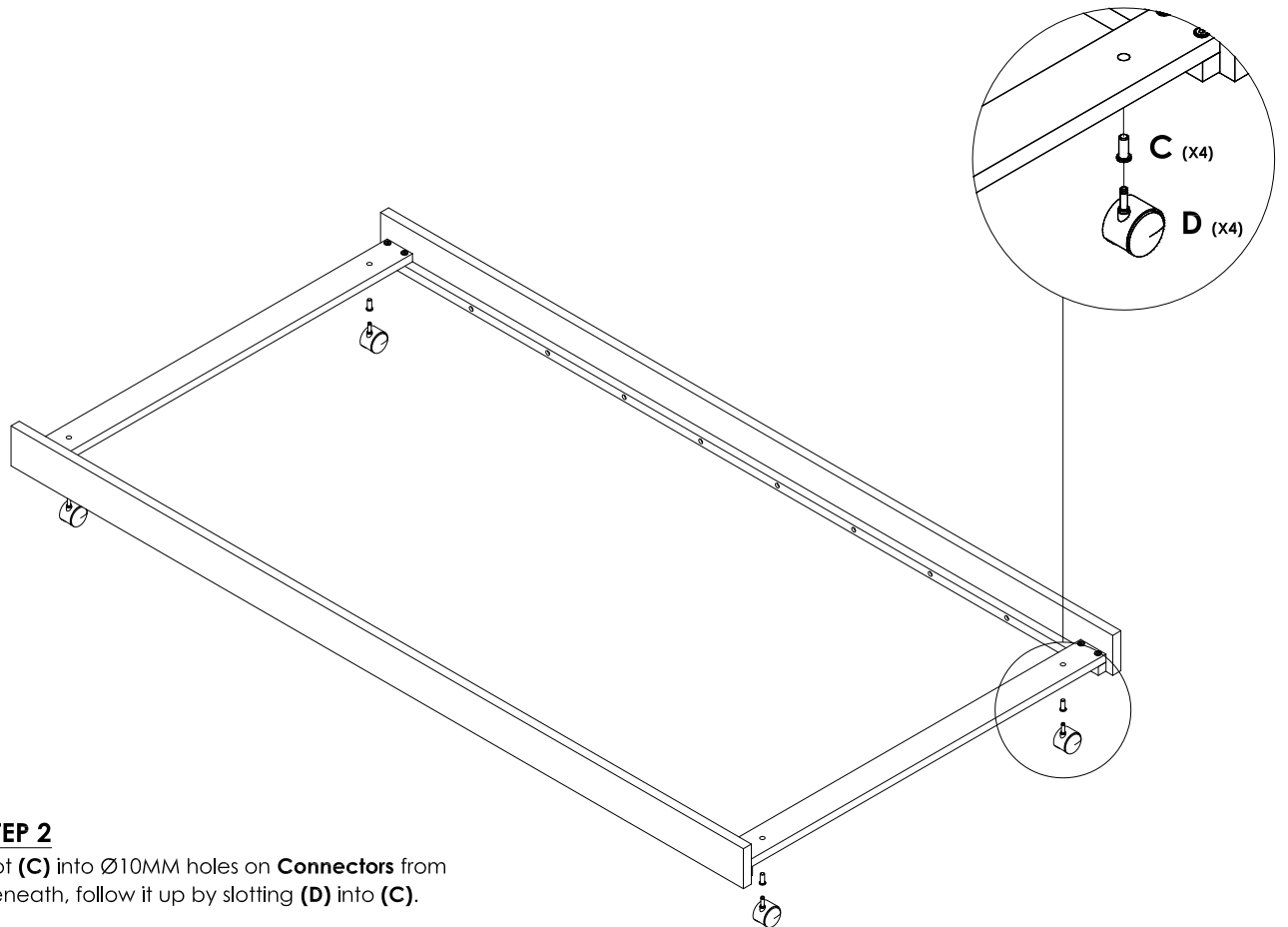

**STEP 2**

Slot **(C)** into  $\text{\O}10\text{MM}$  holes on **Connectors** from beneath, follow it up by slotting **(D)** into **(C)**.

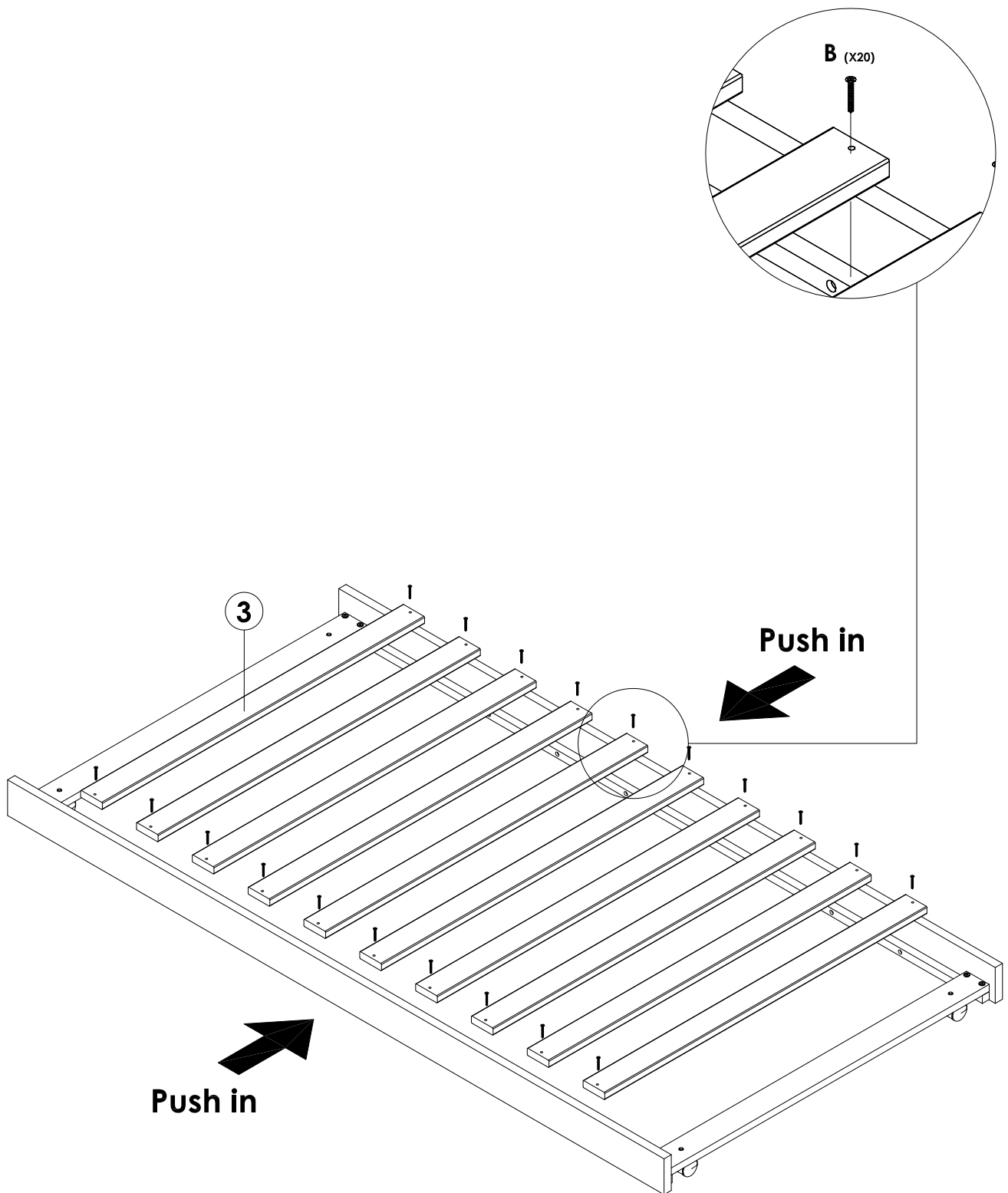

### STEP 3

Attach and secure **Wooden Slat** onto both **Side Rail** by using **(B)**, tighten it up by using a Crosshead Screw Driver. Go on to complete the entire assembly.

#### Remark:

i). Please lift up one side of Headboard to straighten the bed.

ii). Align the last and first slat and tighten the screw on both end side.

iii). Side Rail is flexible, screw on one side of centre slat first, then push the other side on the centre part of the side rail gently then tighten the screw. If necessary you may need to push the centre of side rail and pull the slat gently toward you all the same time which will close the gap.

iv). Tighten the rest of the screw.