

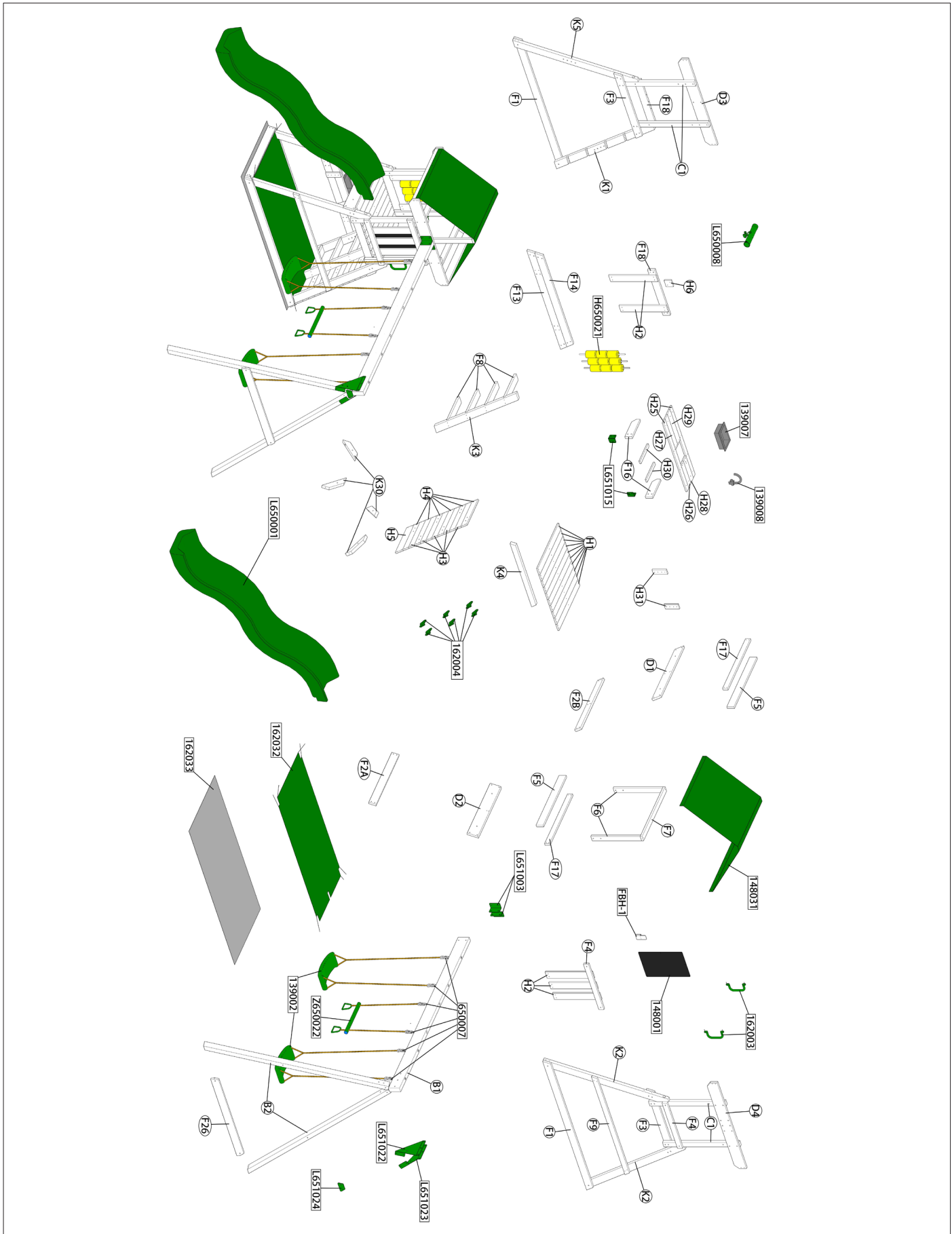









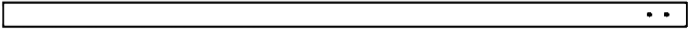
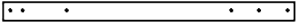

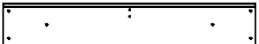
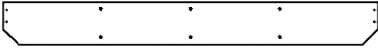
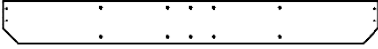
III. EXPLODED DIAGRAM

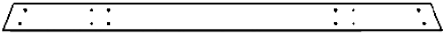
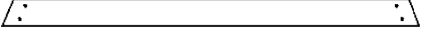

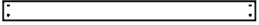
IV. ASSEMBLY INSTRUCTIONS

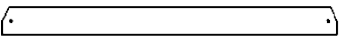
BOARD LIST

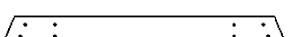
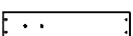
B1 = 1	
	2420x134x50mm
B2 = 2	
	2159x76x50mm
C1 = 4	
	921x60x35mm
D1 = 1	
	800x134x24mm
D2 = 1	
	800x134x24mm
D3 = 1	
	1186x134x24mm
D4 = 1	
	1186x134x24mm
F1 = 2	
	1781x86x24mm
F13 = 1	
	1781x86x24mm
F14 = 1	
	1318x86x24mm
F16 = 2	
	282x86x24mm
F17 = 2	
	800x60x24mm
F18 = 2	
	626x86x24mm
F26 = 1	
	1056x86x24mm
F2A = 1	
	800x86x24mm
F2B = 1	
	800x86x24mm
F3 = 2	
	894x86x24mm
F4 = 2	
	626x60x24mm

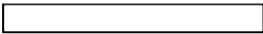
F5 = 2 
800x86x24mm

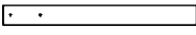
F6 = 2 
596x60x24mm

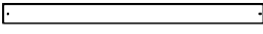
F7 = 1 
800x60x24mm

F8 = 4 
378x86x24mm

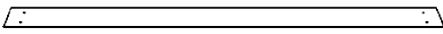
F9 = 1 
1356x60x24mm

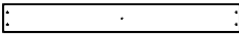
H1 = 10 
728x86x16mm

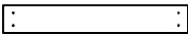
H2 = 5 
568x86x16mm

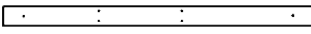
H25 = 2 
952x60x16mm

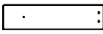
H26 = 1 
310x76x16mm

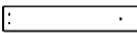
H27 = 1 
422x76x16mm

H28 = 1 
310x86x16mm

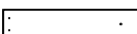
H29 = 1 
422x86x16mm

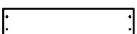
H3 = 5 
400x86x16mm

H30 = 2 
280x35x16mm

H31 = 2 
170x60x16mm

H4 = 6 
400x86x16mm

H5 = 1 
400x110x16mm

H6 = 1 
86x86x16mm

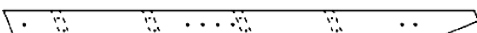
K1 = 1 
1462x86x35mm

K2 = 2 
1462x86x35mm

K3 = 1 
1247x86x35mm

K30 = 4 
300x60x35mm

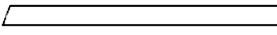
K4 = 1 
873x60x35mm

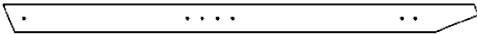
K5 = 1 
1462x86x35mm

PARTS LIST

W8/15 
Washer x 12

W10/18 
Washer x 54

W12/28 
Washer x 6

BM615 
B-NUT x 12

BM818 
B-NUT x 23

N815 
NUT x 60

AN8 
A-NUT8 x 6

 M821
Bolt x 12

SW16 
Screw x 18

S328 
Screw x 4

 M625
Bolt x 12

SW35 
Screw x 136

 M845
Bolt x 13

SW50 
Screw x 48

SW60 
Screw x 4

 M855
Bolt x 48

M6SW35 
Screw x 20

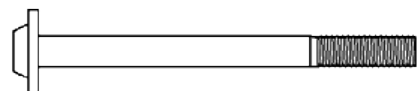
 M896
Bolt x 2

M6SW55 
Screw x 27

 M869
Bolt x 2

SW28 
Screw x 16

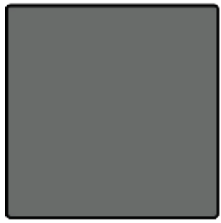

(1) 148001: 530*340mm

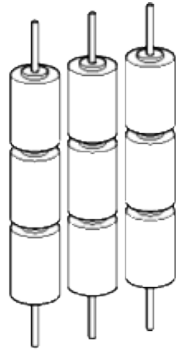

(1) H650021



(1) L651022

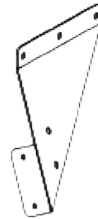

(1) L651023

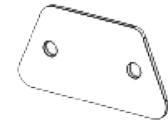

(1) L651024

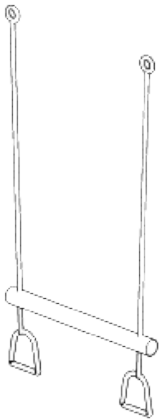

(1) L650050

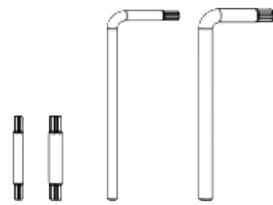

Star Bit (S)
Star Bit (L)
Allen Wrench (S)
Allen Wrench (L)



(6) 650007

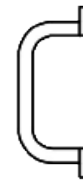

(2) 162003



(6) 162004

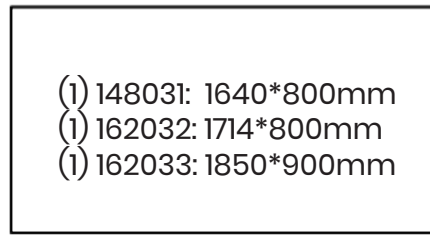

(1) 148031: 1640*800mm
(1) 162032: 1714*800mm
(1) 162033: 1850*900mm



(1) FBH-1



(2) 139002

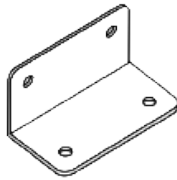

(2) L651015

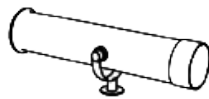

(1) L650008

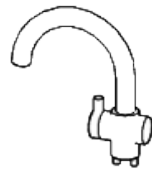

(1) 139008

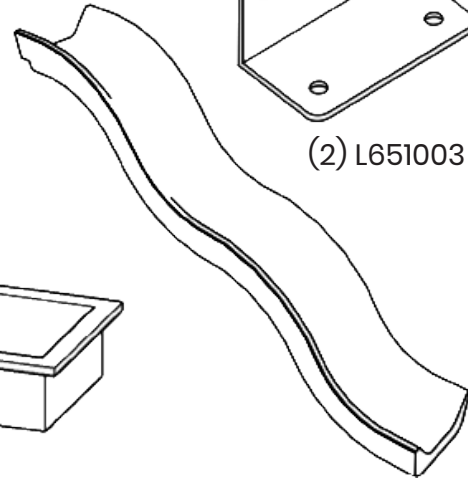

(1) L650001

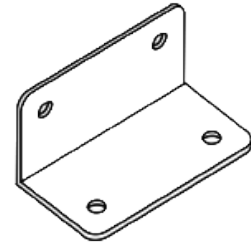

(2) L651003



(6) 139070



(1) 162090

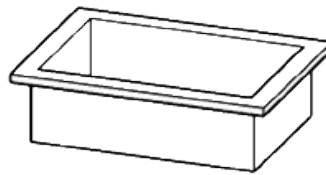

(1) 139007

STEP 1

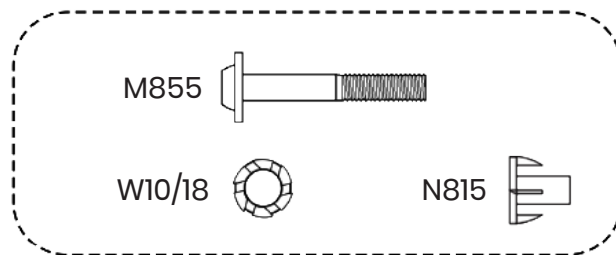
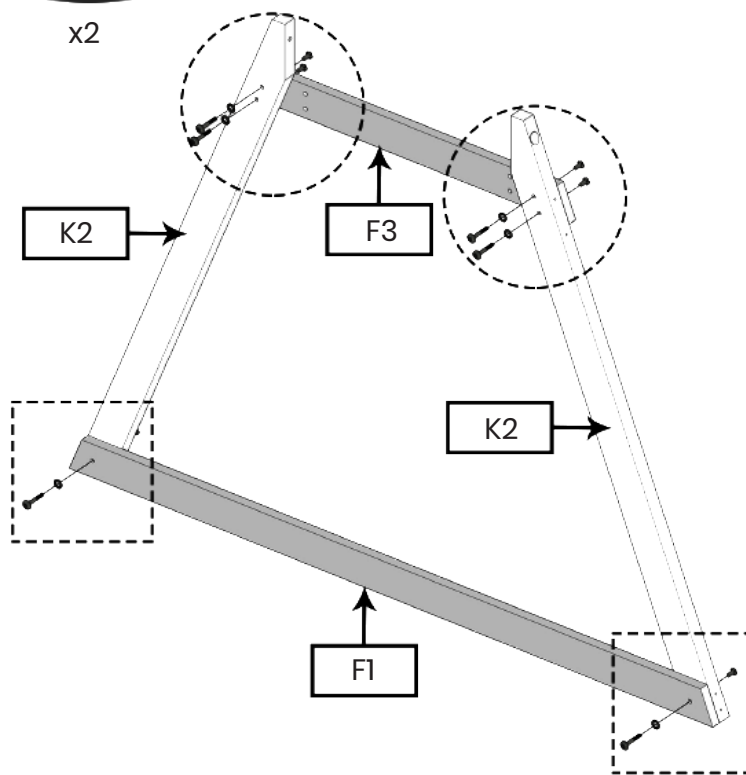
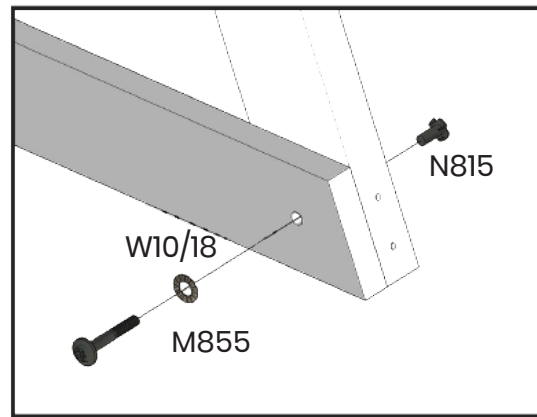
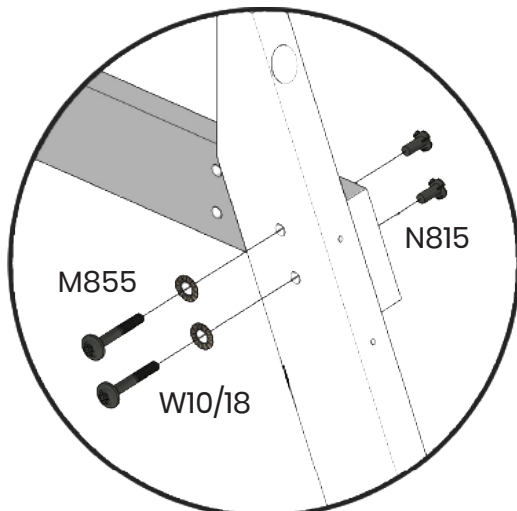

List	
Part No.	Qty.
F1	1
F3	1
K2	2
M855	6
W10/18	6
N815	6

STEP 2

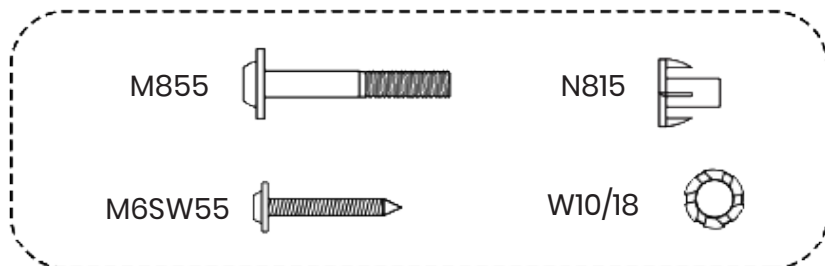
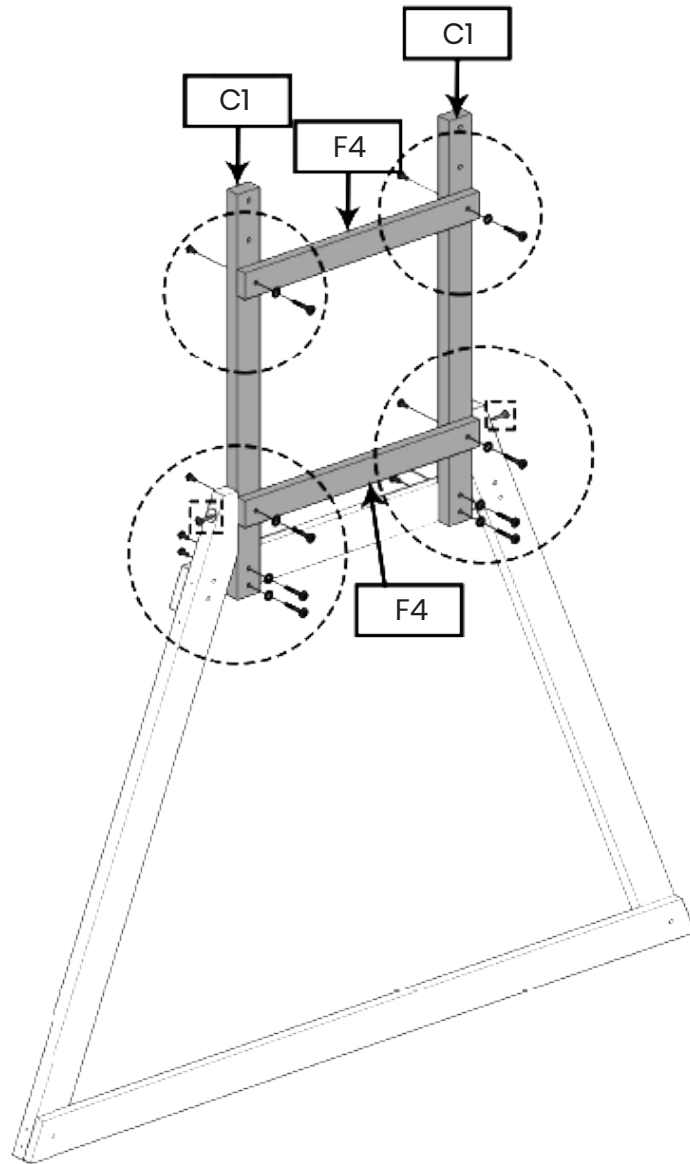
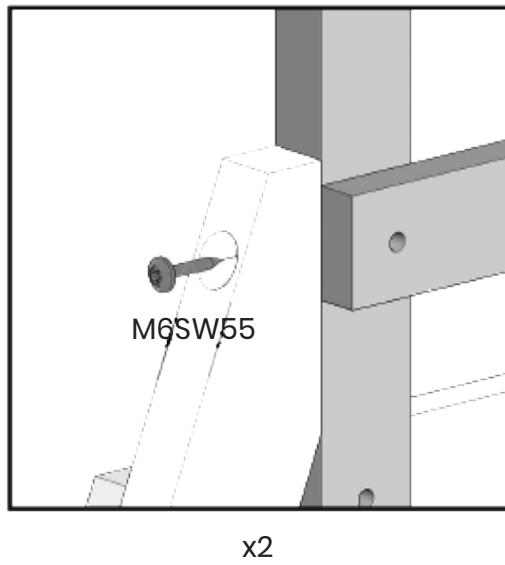
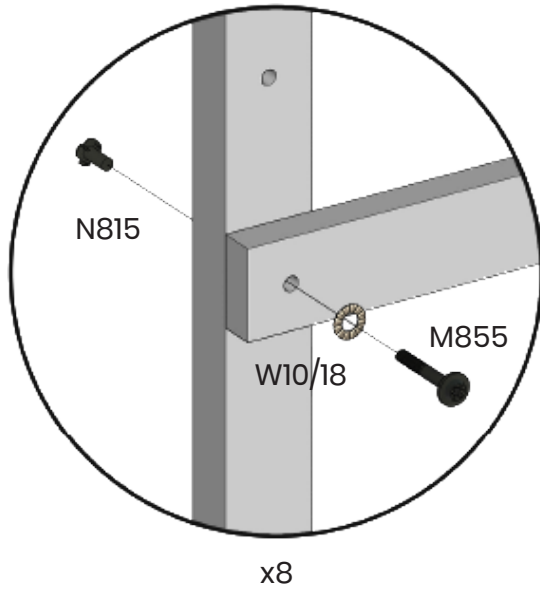

List	
Part No.	Qty.
C1	2
F4	2
M855	8
W10/18	8
N815	8
M6SW55	2

STEP 3

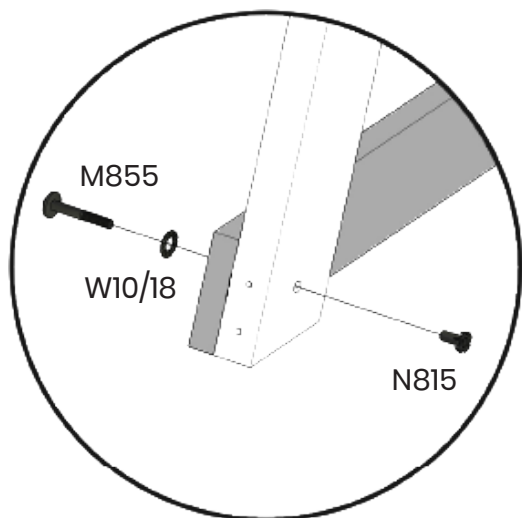

x14

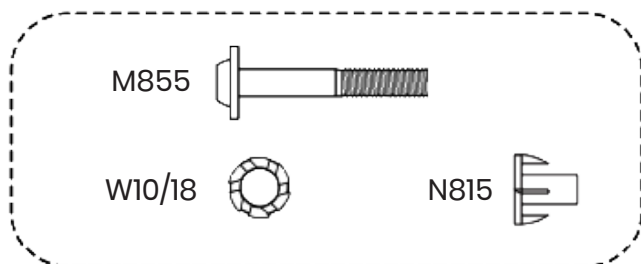
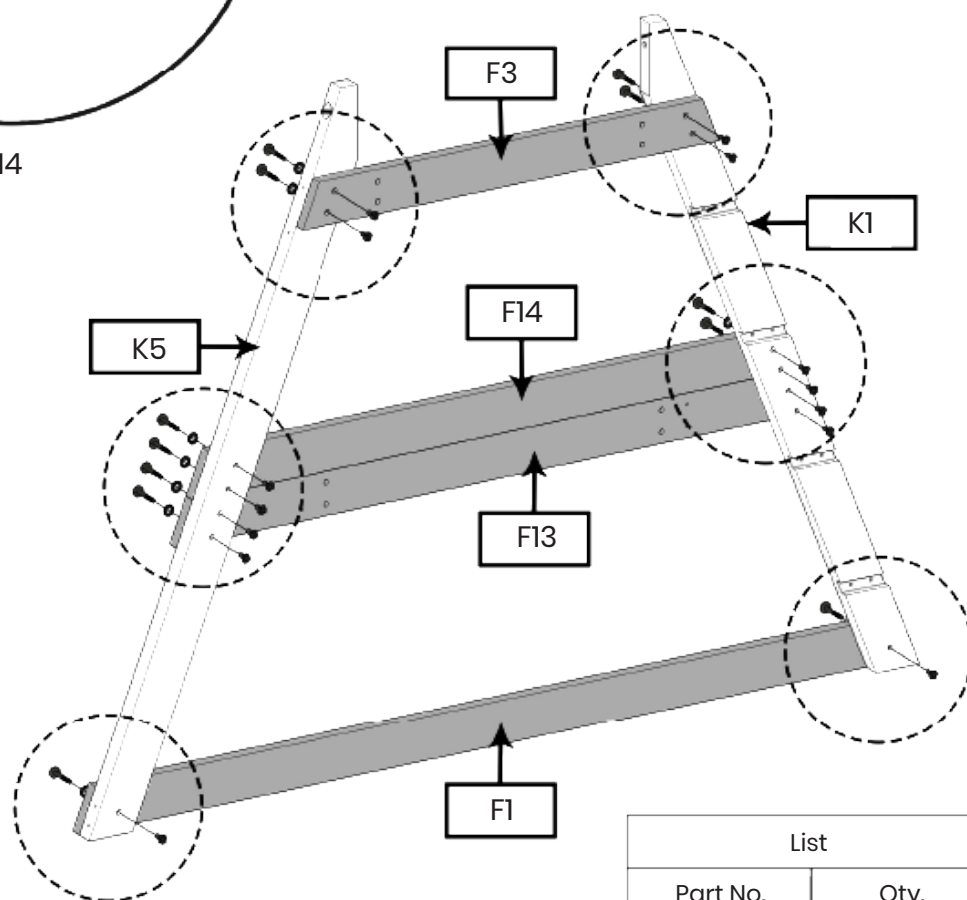

List	
Part No.	Qty.
F1	1
F3	1
F13	1
F14	1
K1	1
K5	1
M855	14
W10/18	14
N815	14

STEP 4

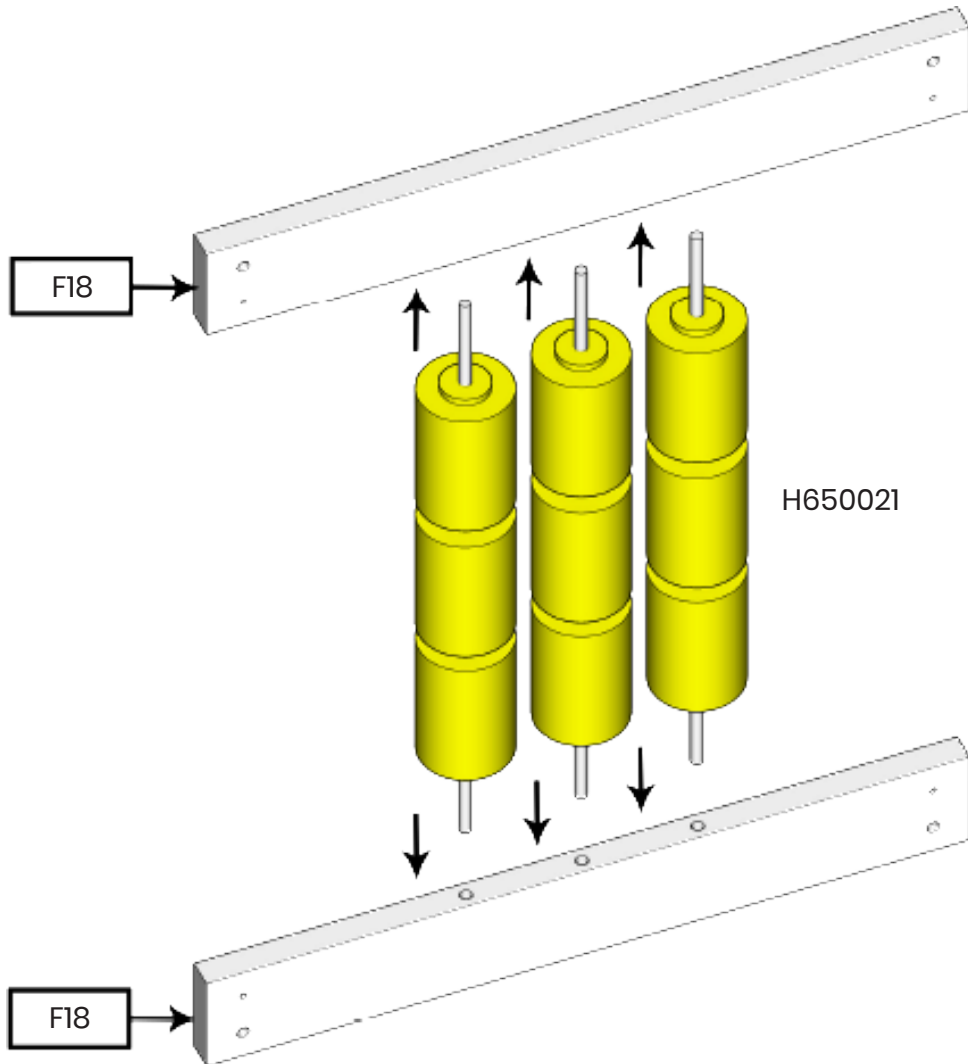

List	
Part No.	Qty.
F18	2
H650021	1

STEP 5

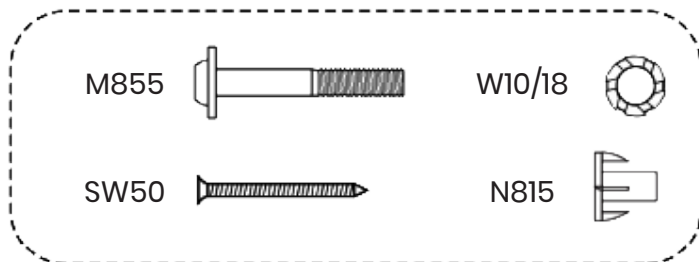
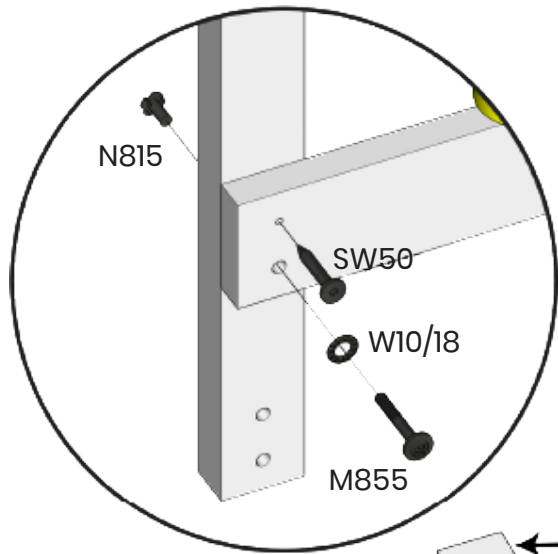
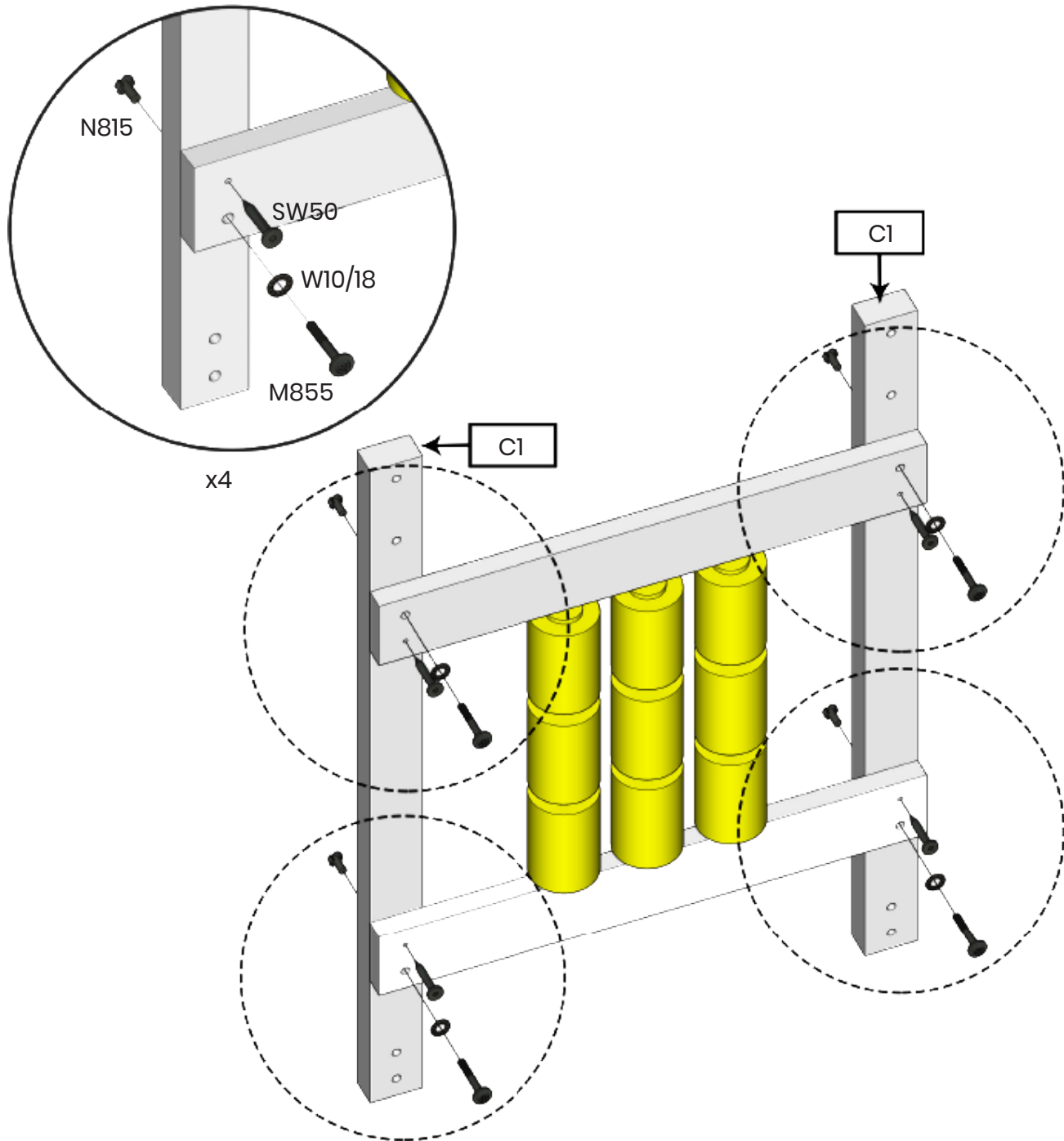

List	
Part No.	Qty.
C1	2
M855	4
W10/18	4
N815	4
SW50	4

STEP 6

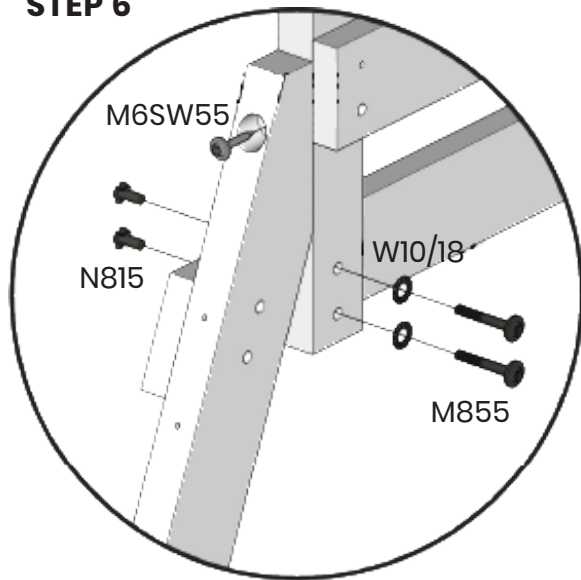

x2

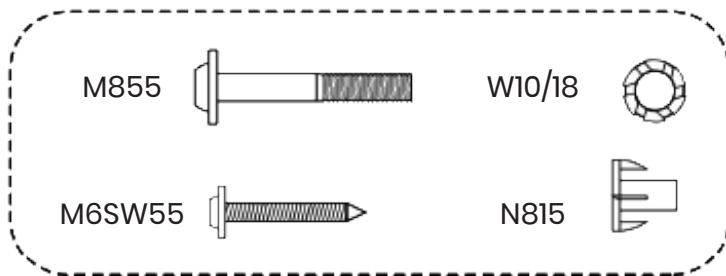
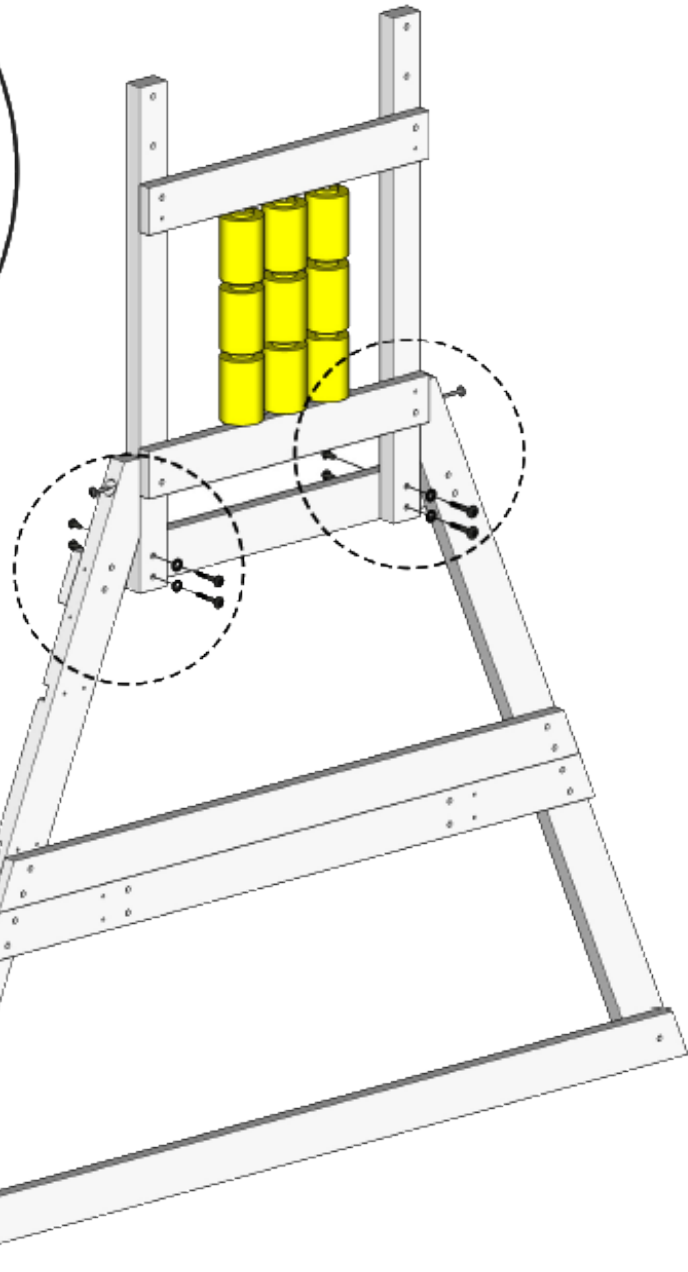

List	
Part No.	Qty.
M855	4
W10/18	4
N815	4
M6SW55	2

STEP 7

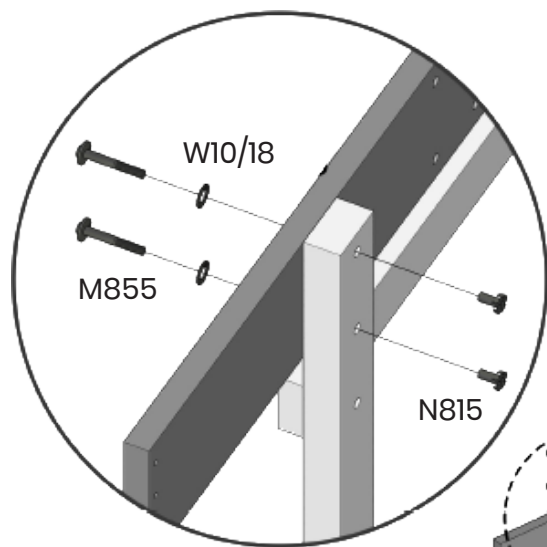

x4

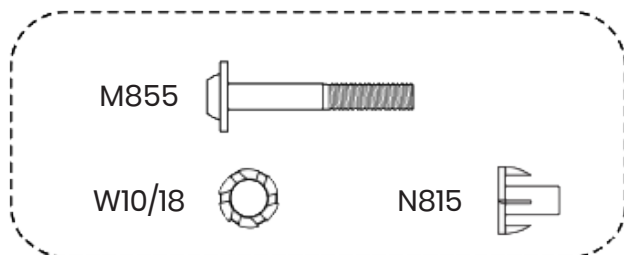
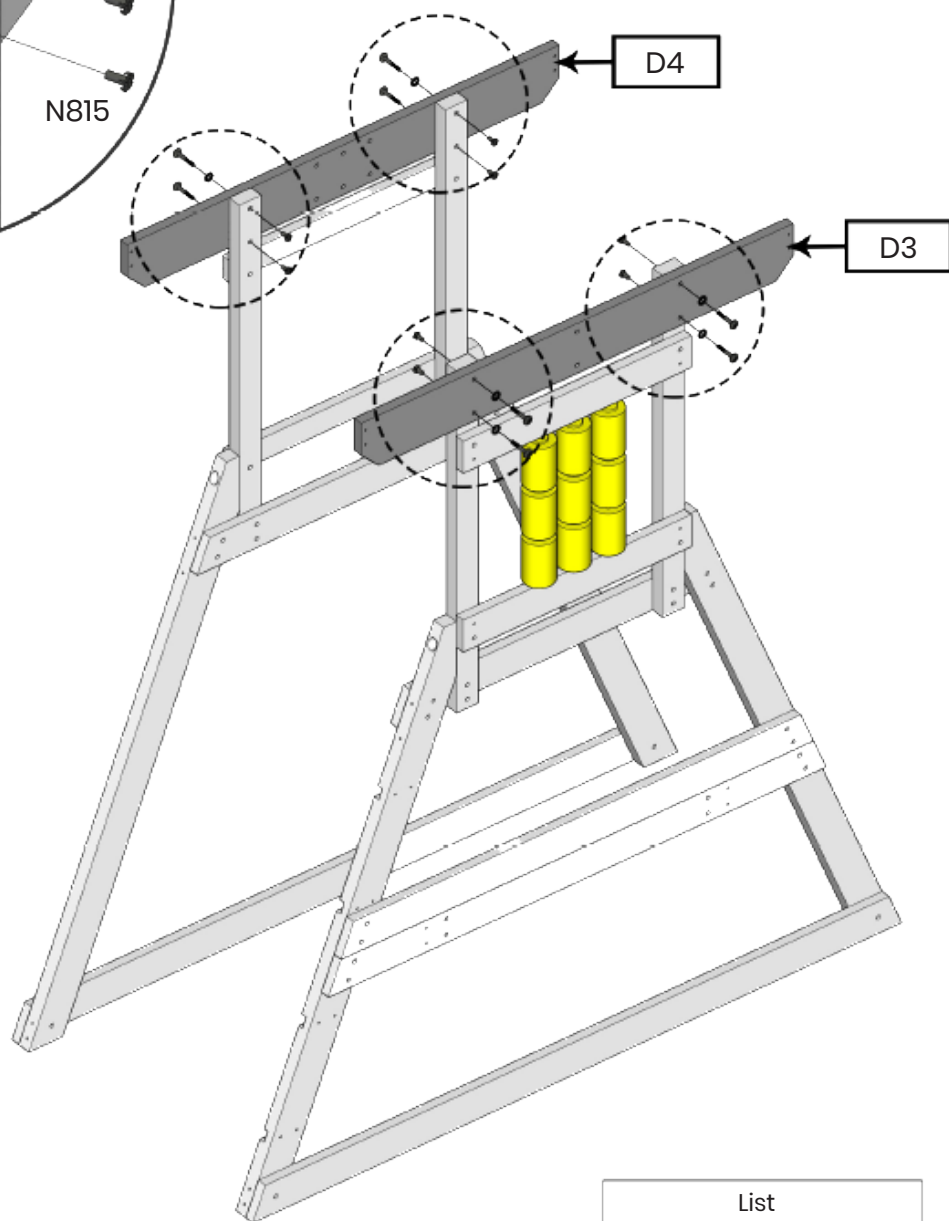

List	
Part No.	Qty.
D3	1
D4	1
M855	8
W10/18	8
N815	8

STEP 8

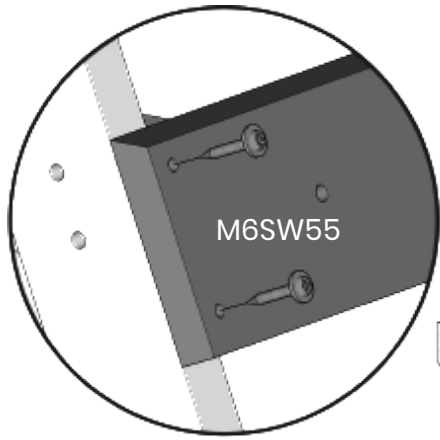

x2

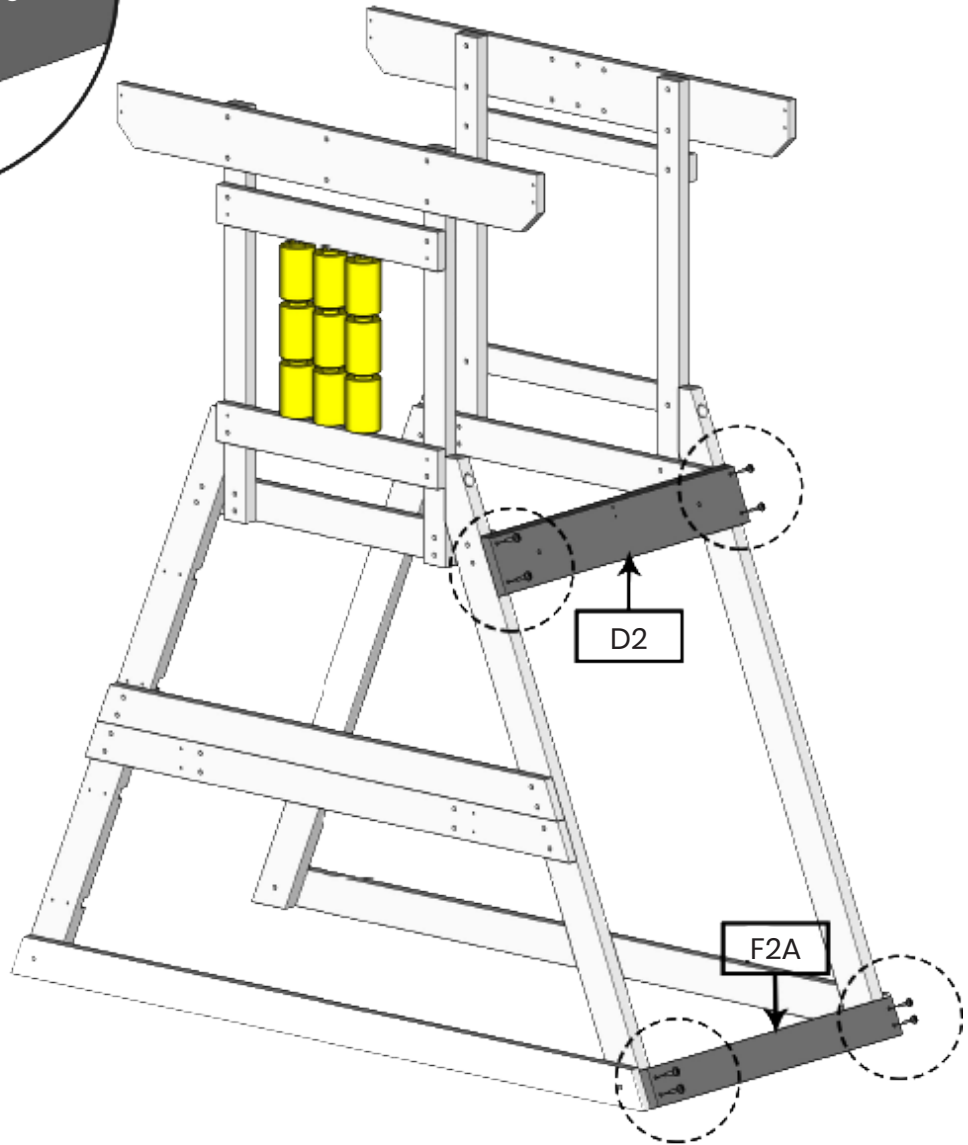

List	
Part No.	Qty.
D2	1
F2A	1
M6SW55	8

STEP 9

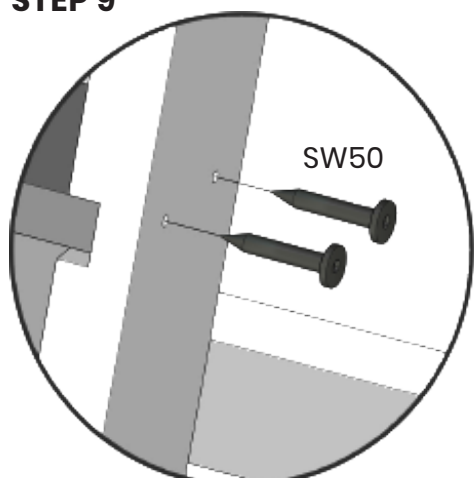

x8

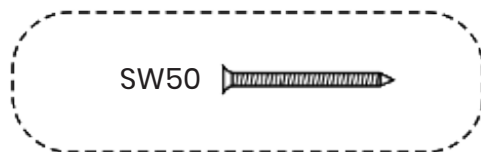
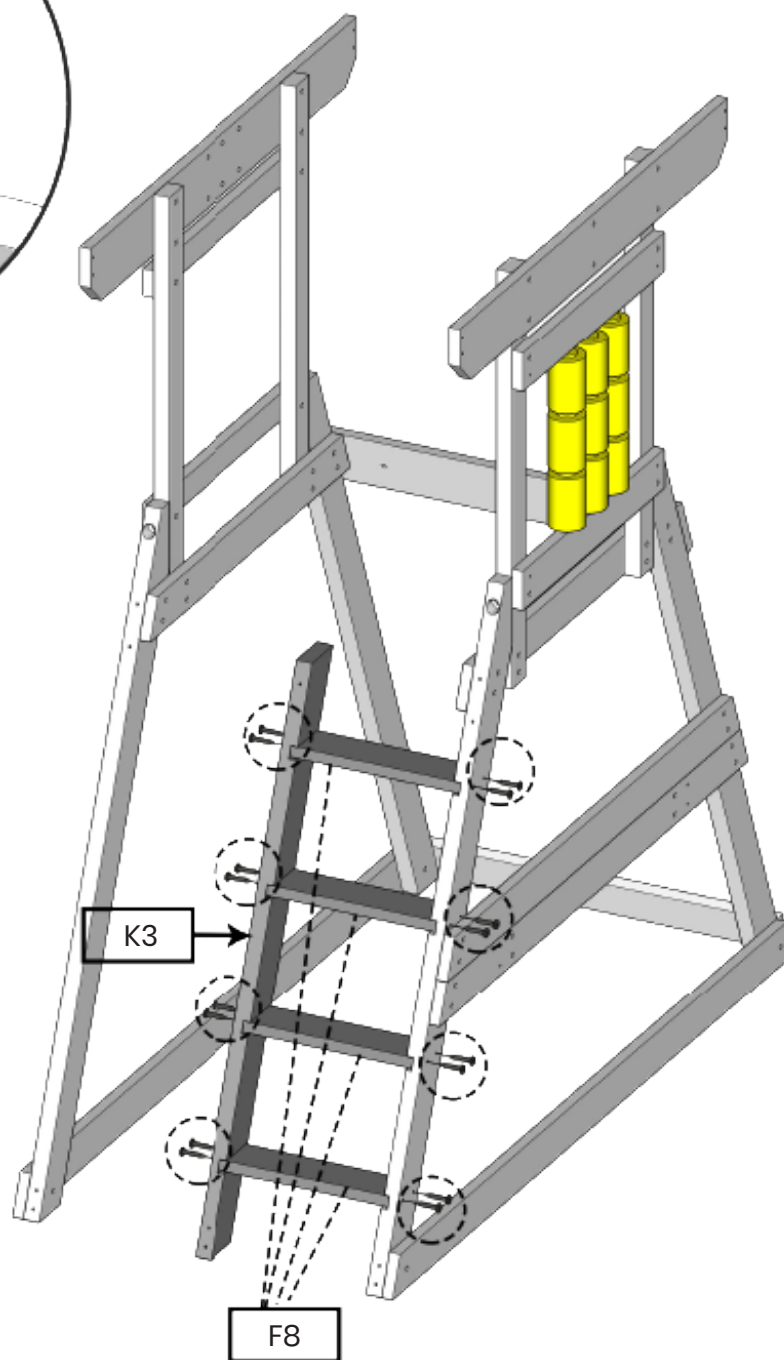

List	
Part No.	Qty.
K3	1
F8	4
SW50	16

STEP 10

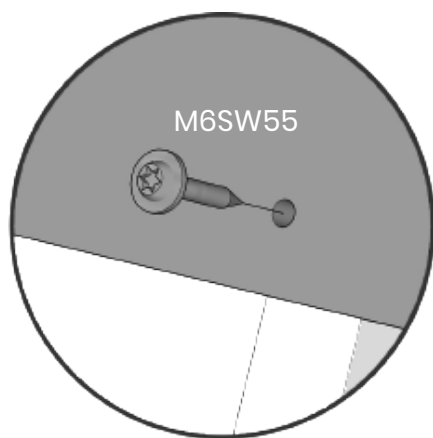

x11

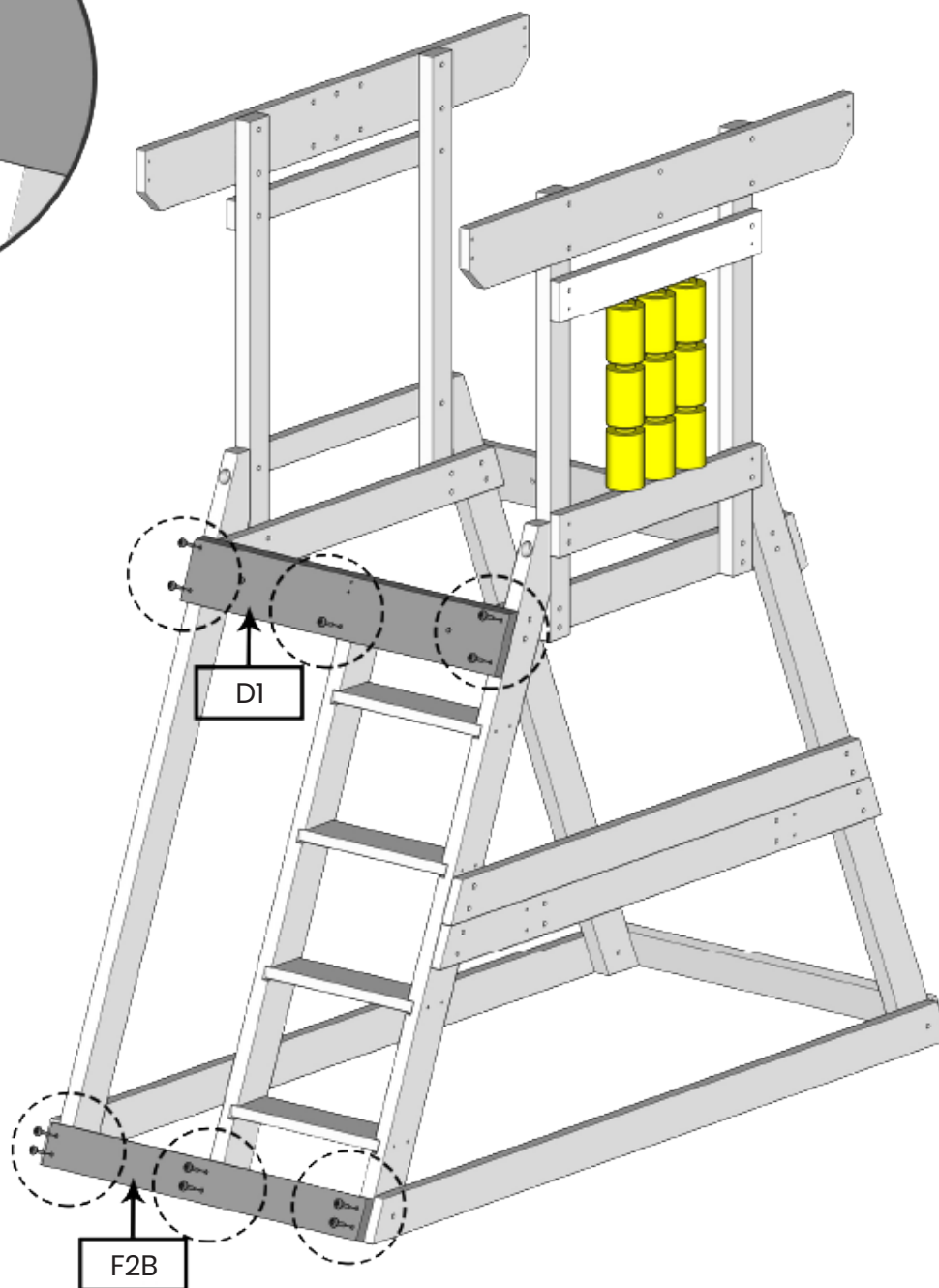

List	
Part No.	Qty.
D1	1
F2B	1
M6SW55	11

STEP 11

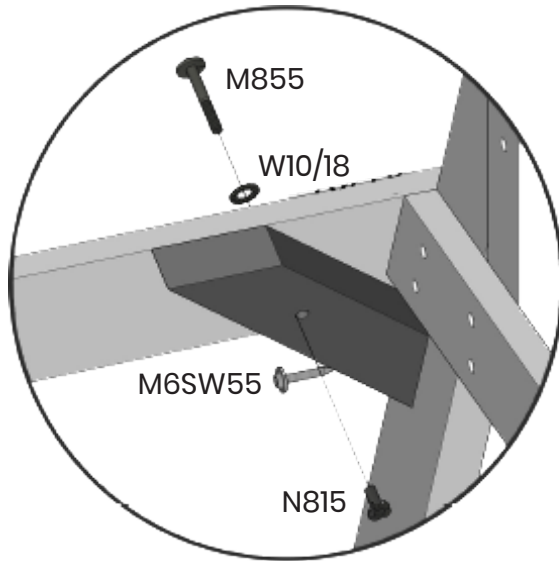

x4

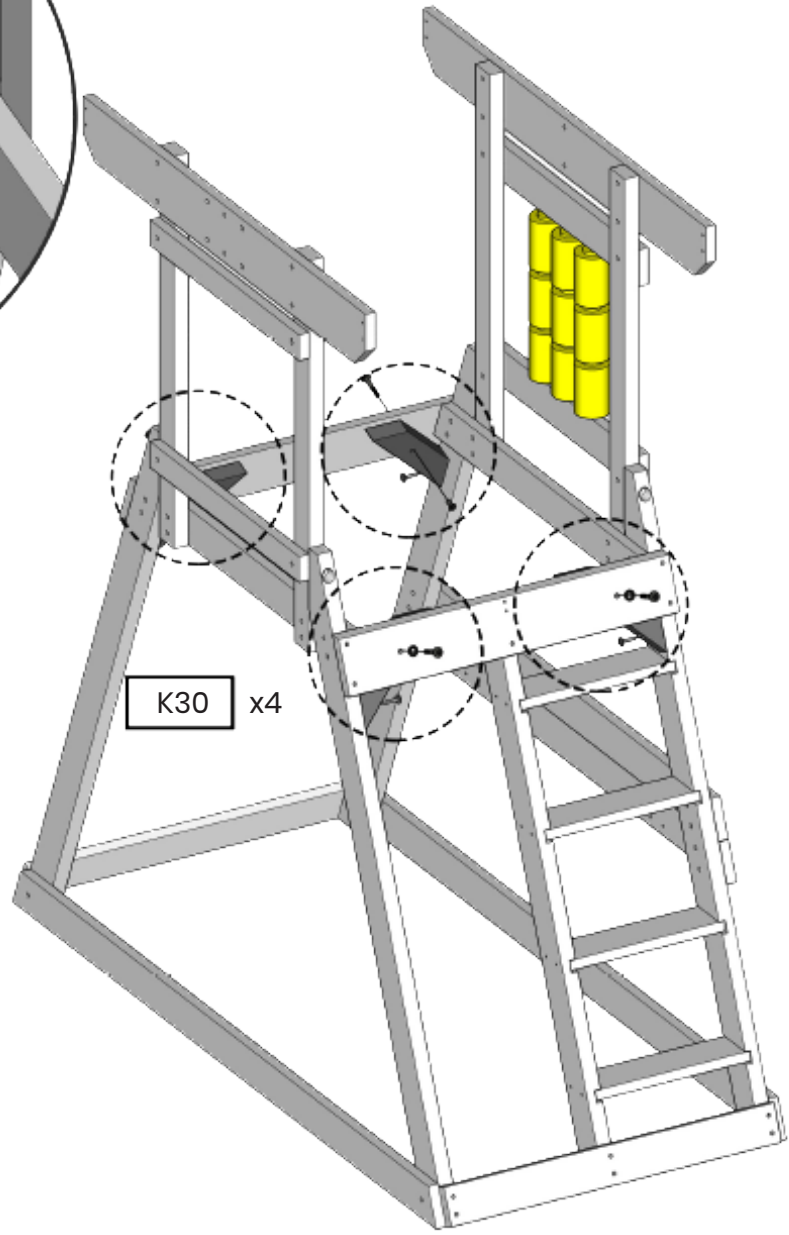

K30 x4

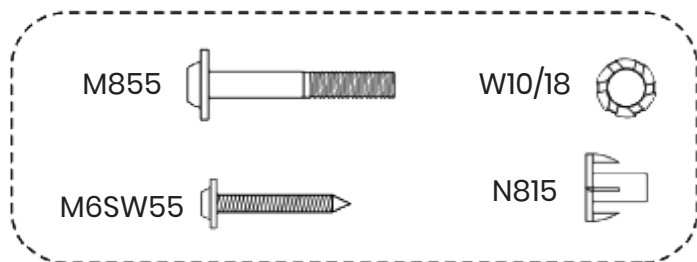

List	
Part No.	Qty.
K30	4
M855	4
W10/18	4
N815	4
M6SW55	4

STEP 12

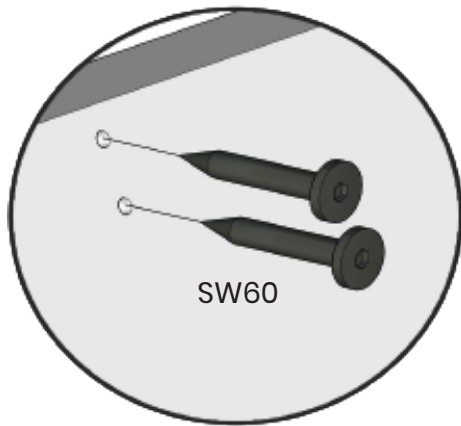

x2

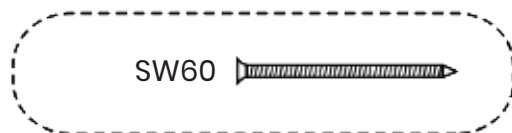
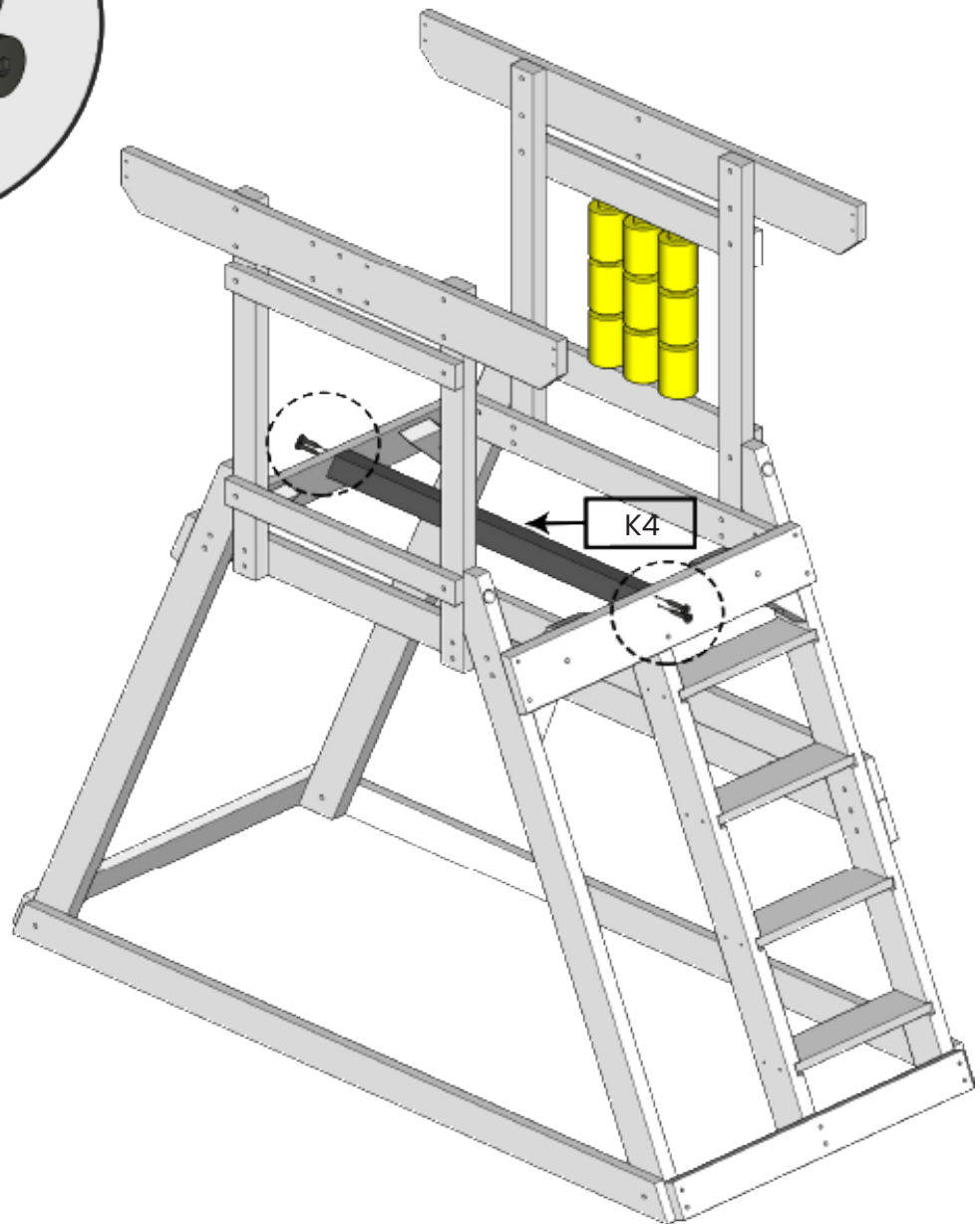

List	
Part No.	Qty.
K4	1
SW60	4

STEP 13

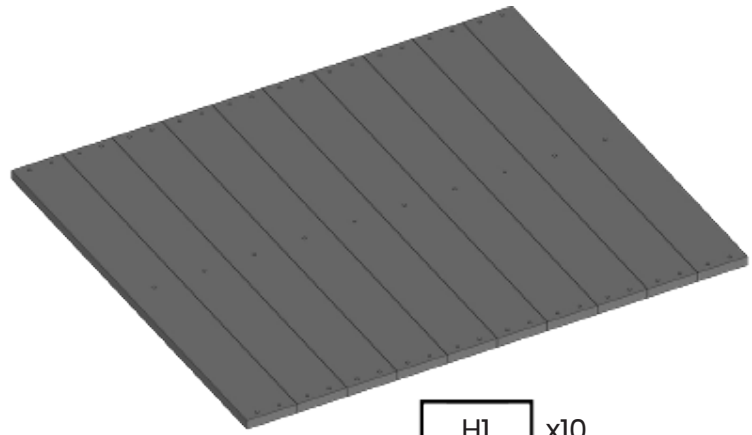

H1 x10

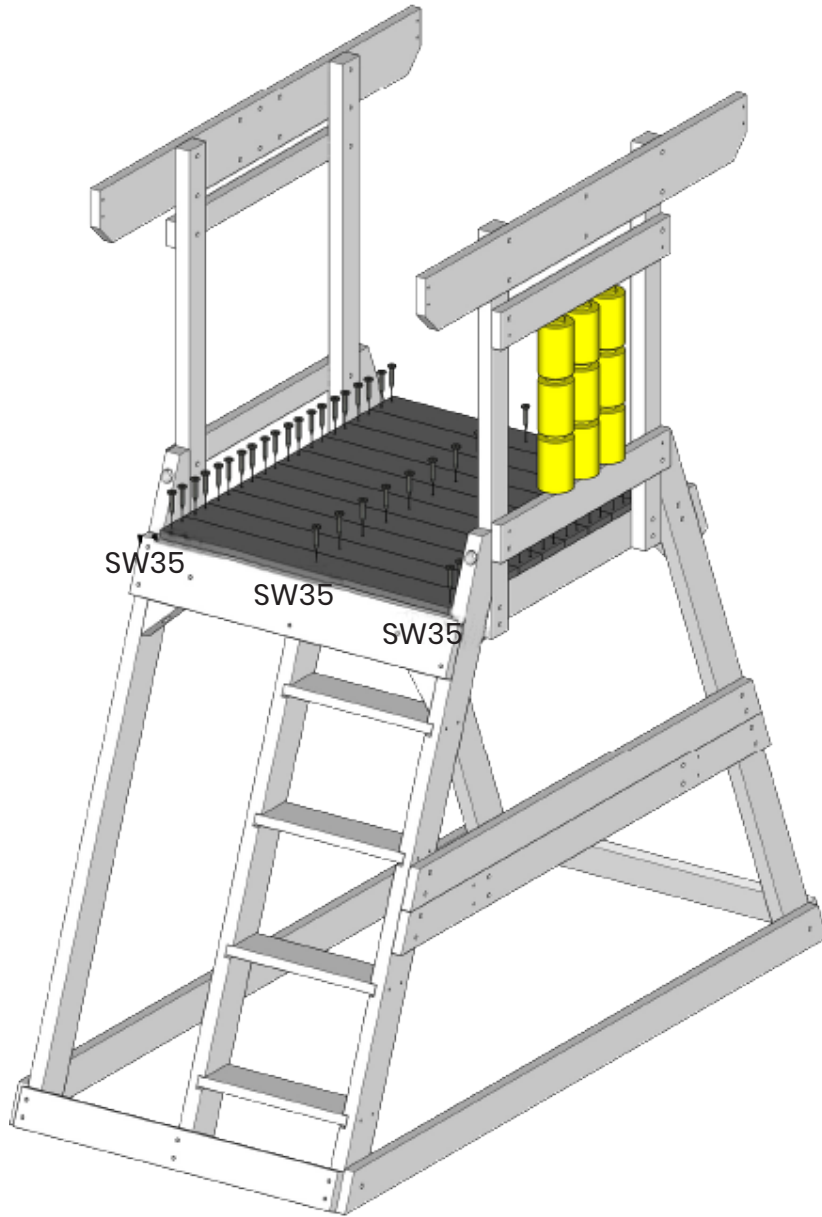

SW35
SW35
SW35



List	
Part No.	Qty.
H1	10
SW35	50

STEP 14

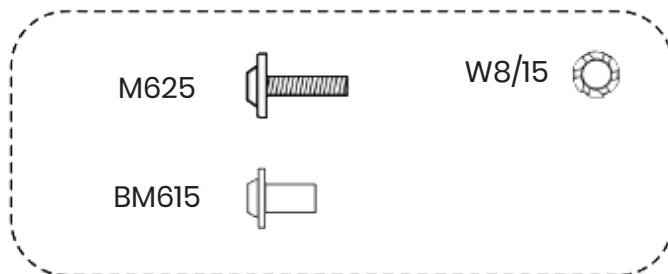
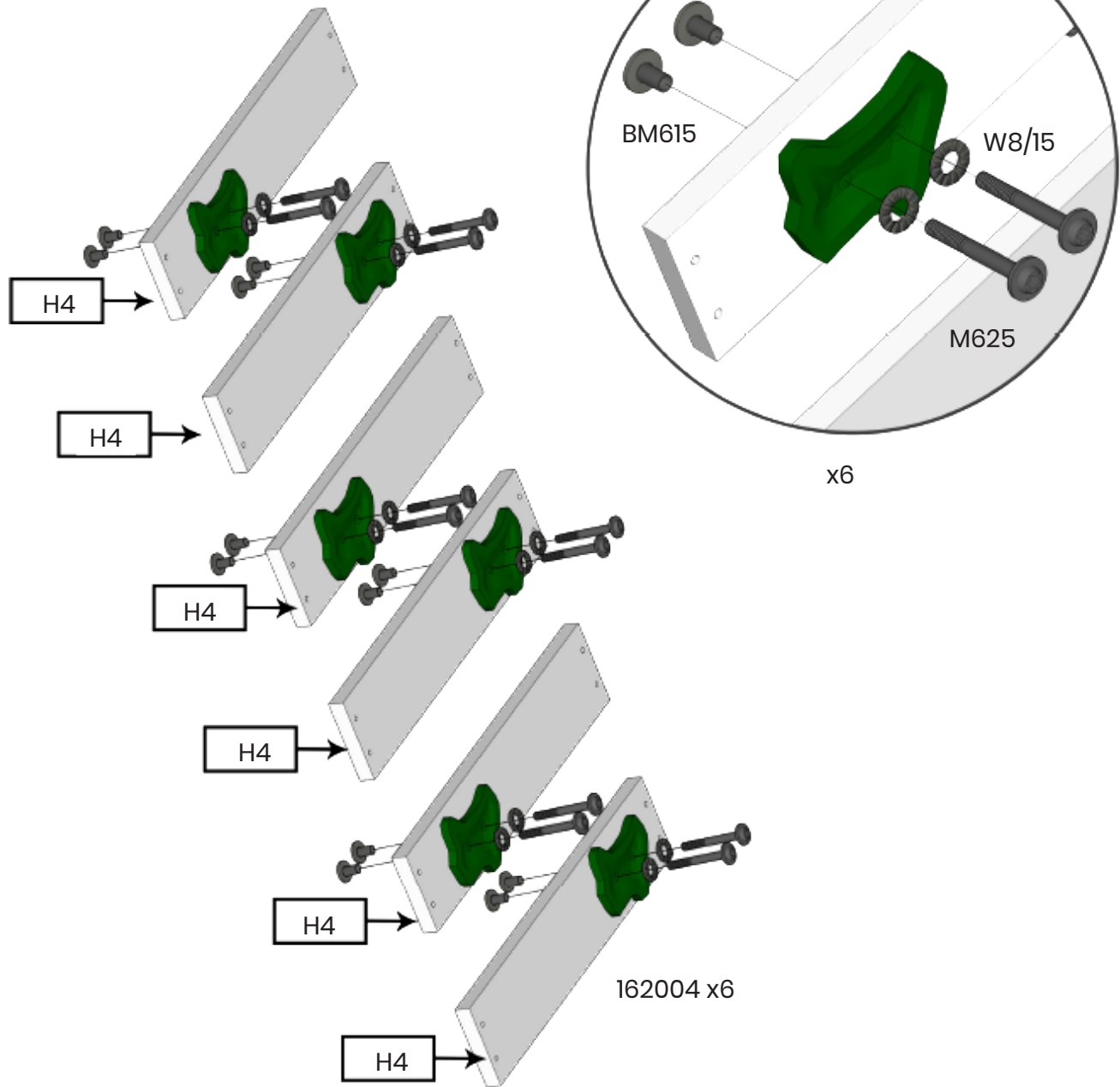

List	
Part No.	Qty.
H4	6
M625	12
W8/15	12
BM615	12
162004	6

STEP 15

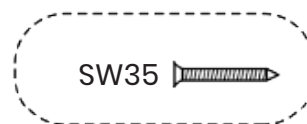
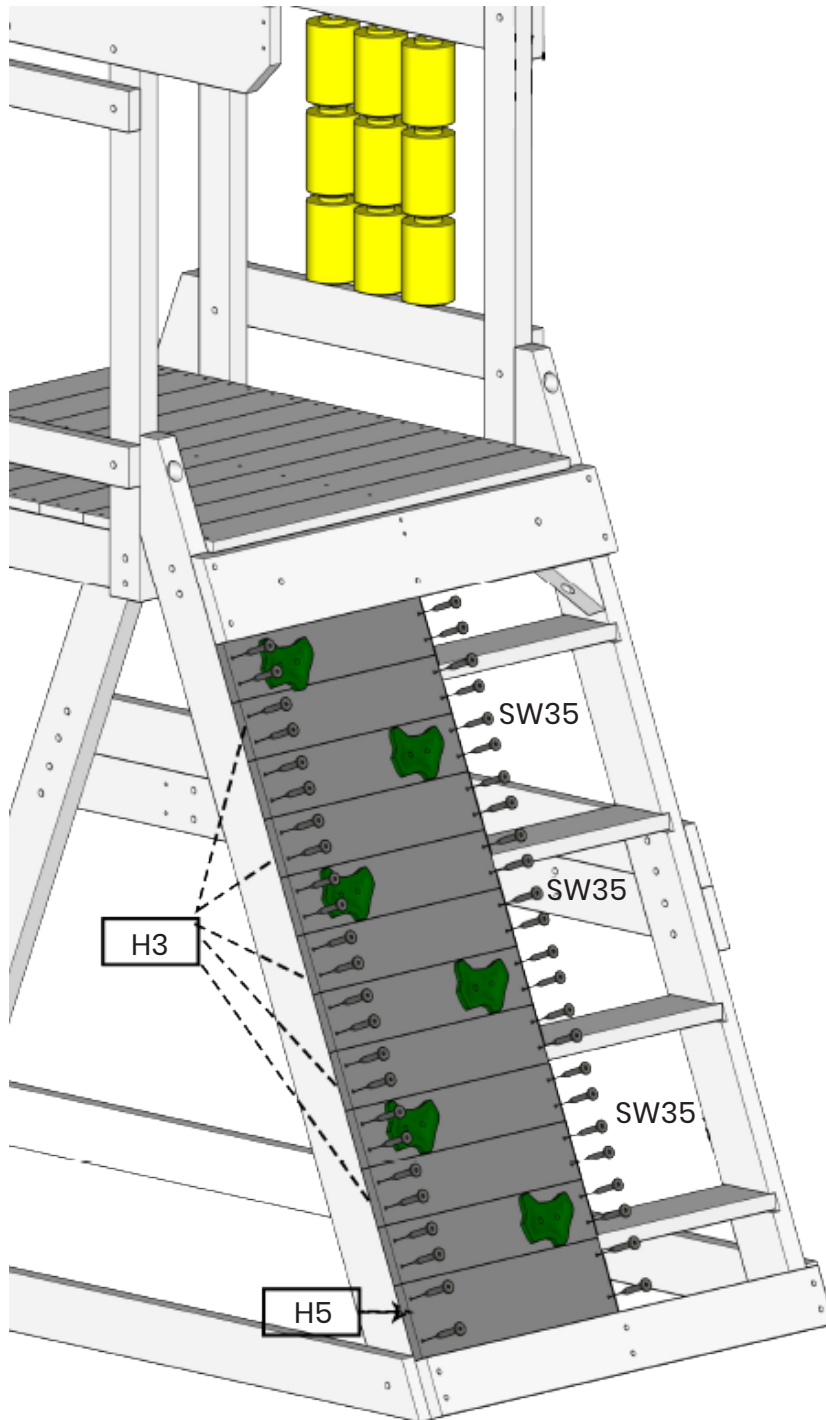

List	
Part No.	Qty.
H3	5
H5	1
SW35	48

STEP 16

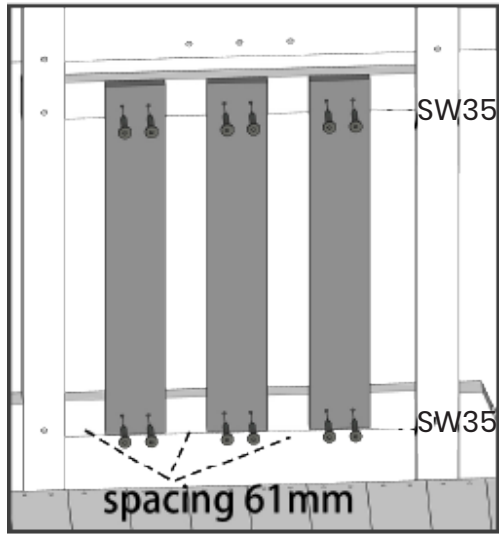

H2 x3

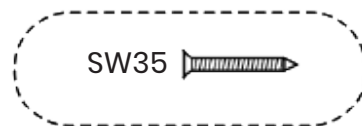
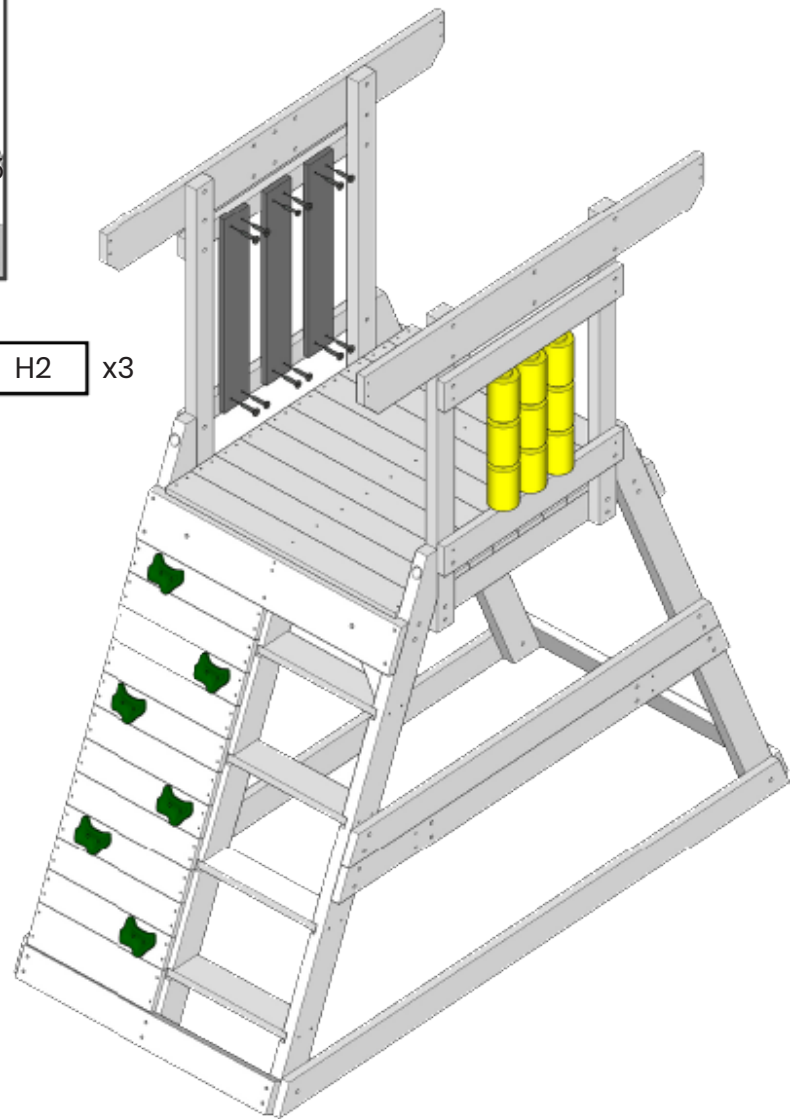

List	
Part No.	Qty.
H2	3
SW35	12

STEP 17

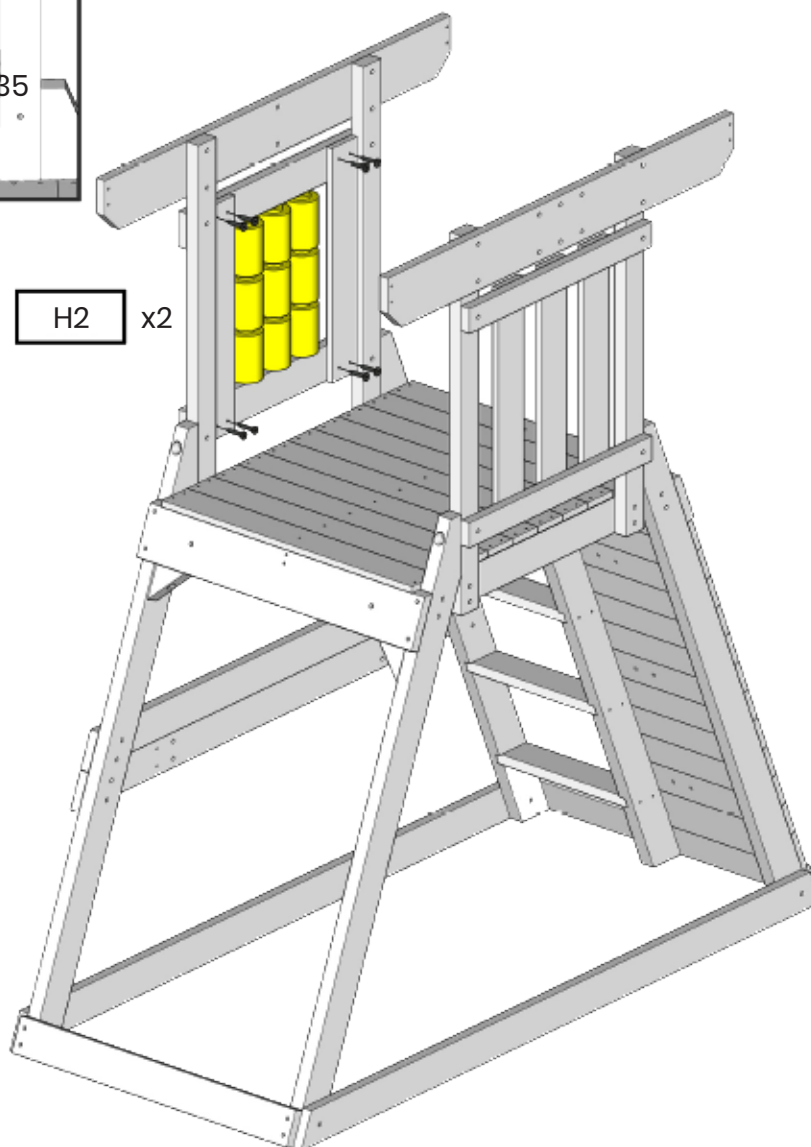
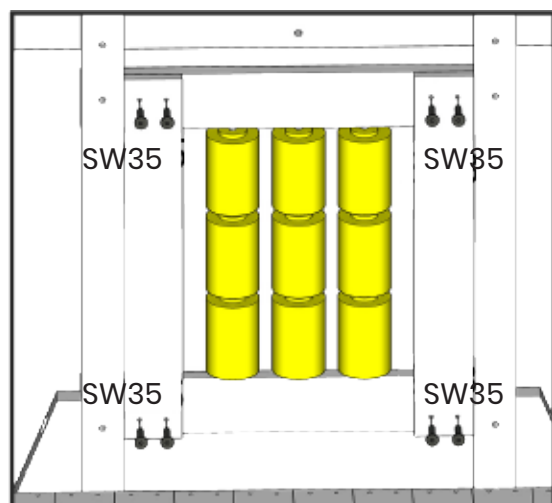

H2 x2

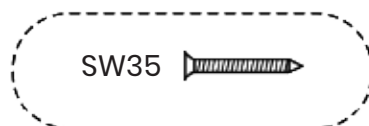

List	
Part No.	Qty.
H2	2
SW35	8

STEP 18

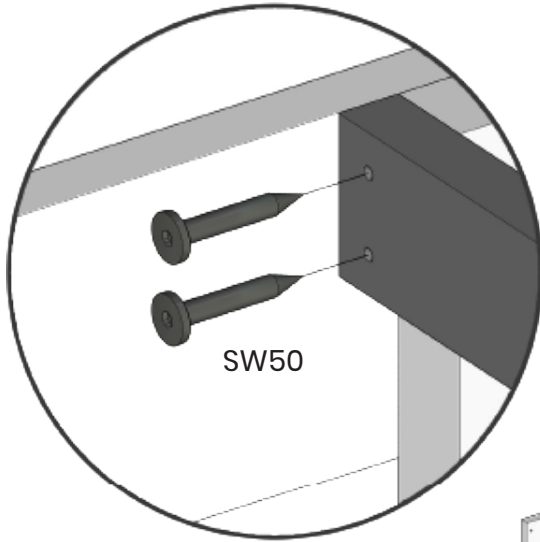

SW50

x4

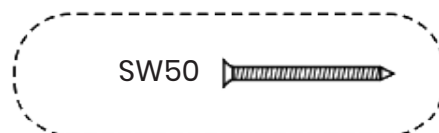
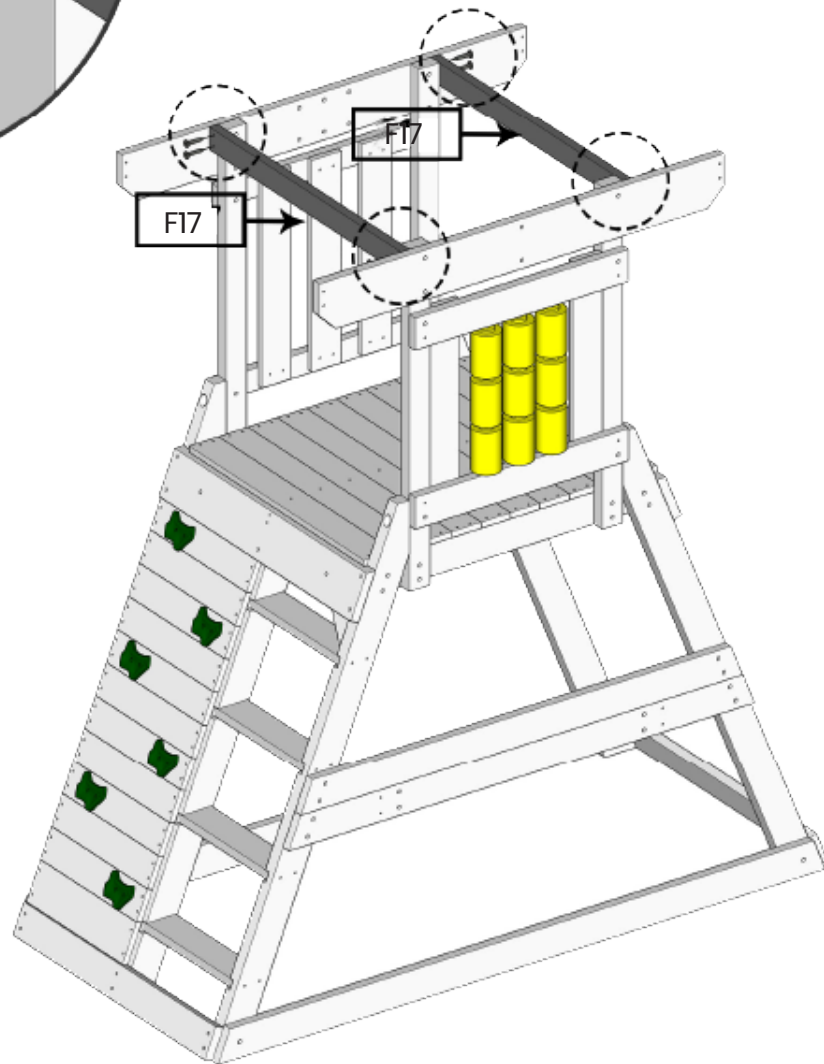

List	
Part No.	Qty.
F17	2
SW50	8

STEP 19

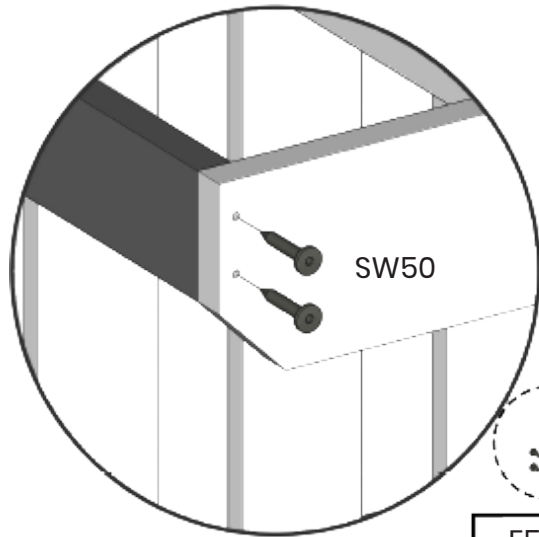

x4

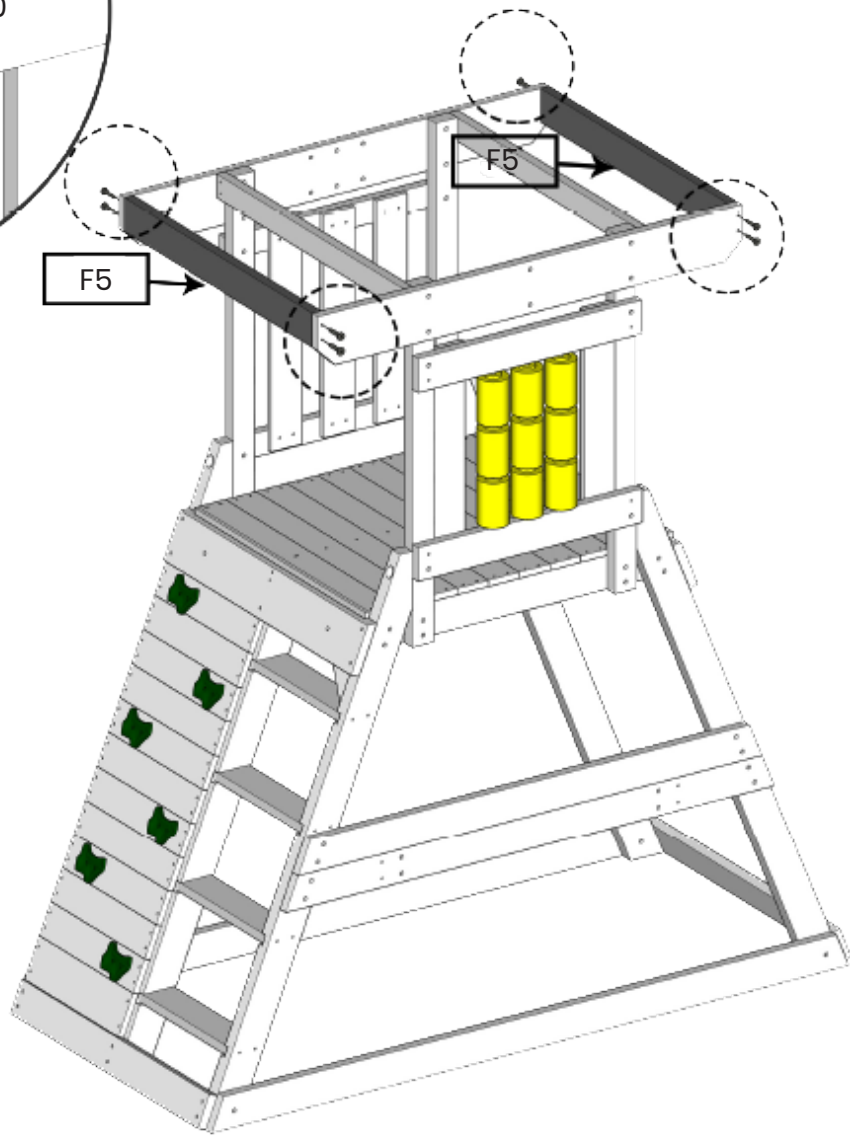

List	
Part No.	Qty.
F5	2
SW50	8

STEP 20

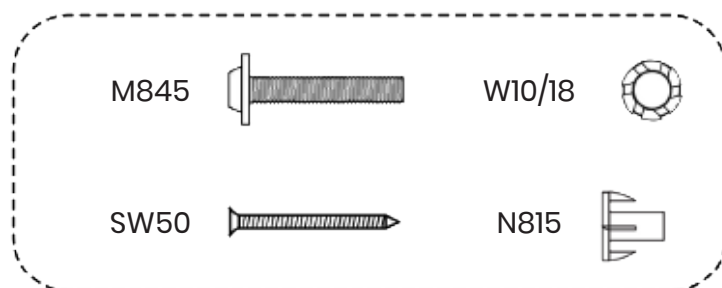
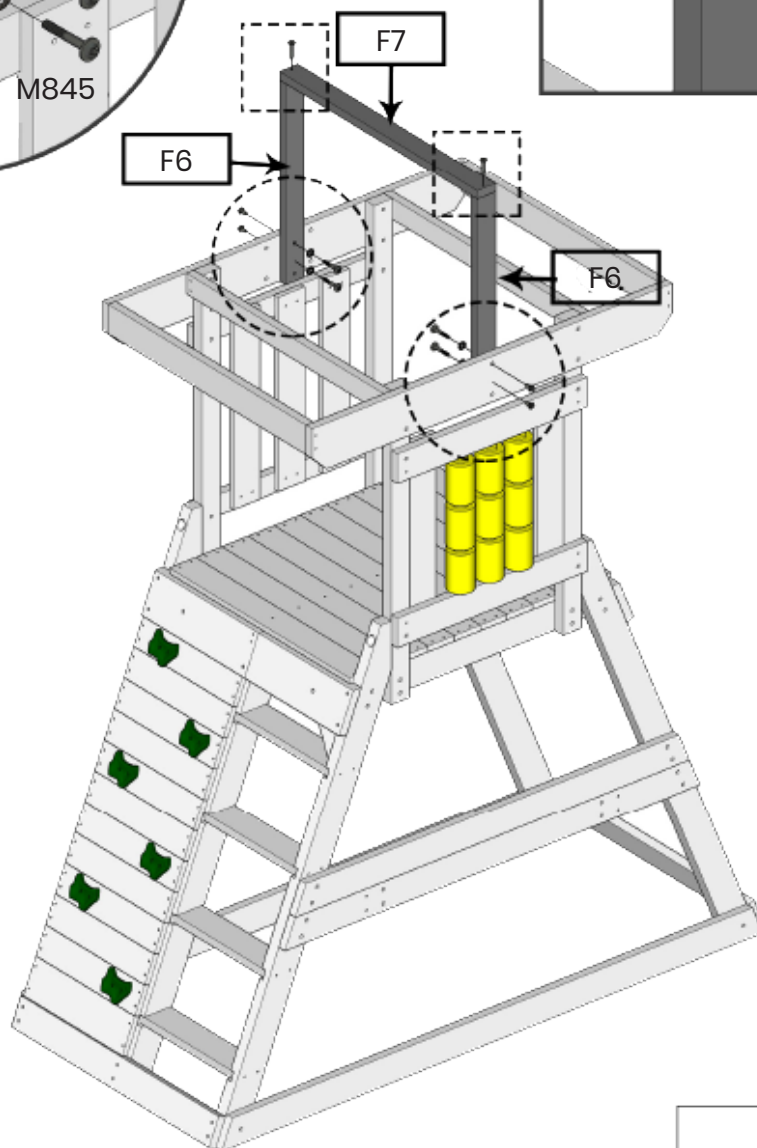
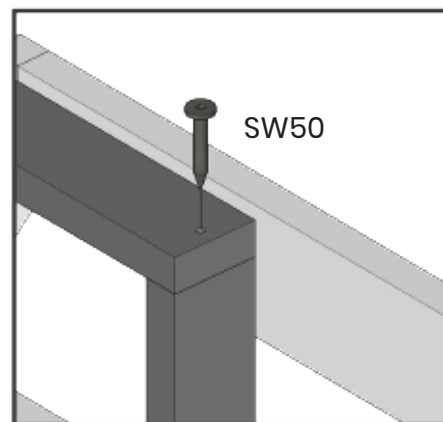
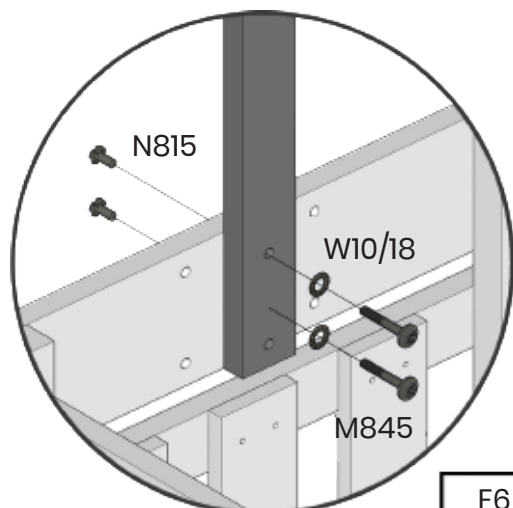

List	
Part No.	Qty.
F6	2
F7	1
M845	4
W10/18	4
N815	4
SW50	2

STEP 21

148031

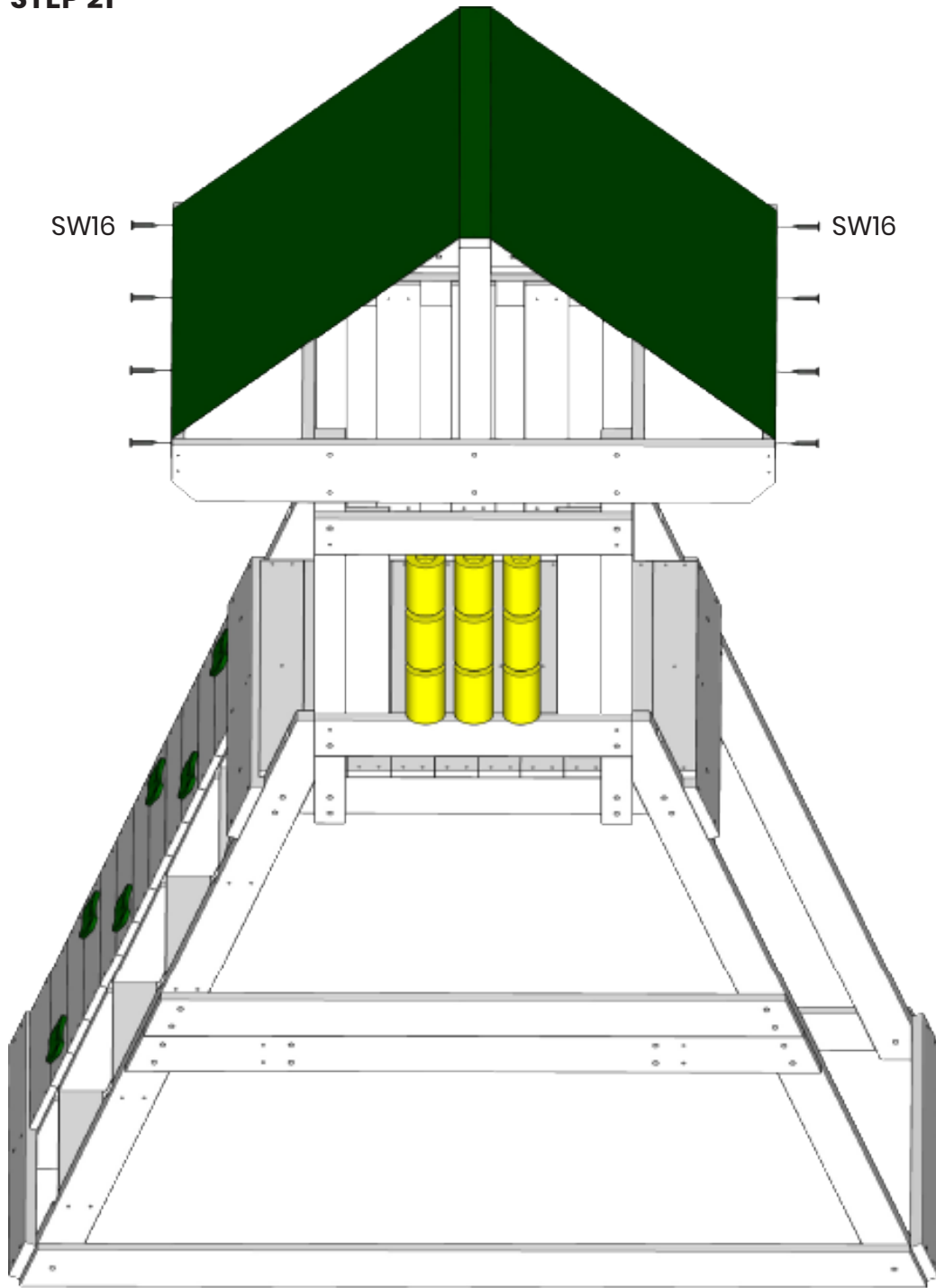

List	
Part No.	Qty.
SW16	8
148031	1

STEP 22

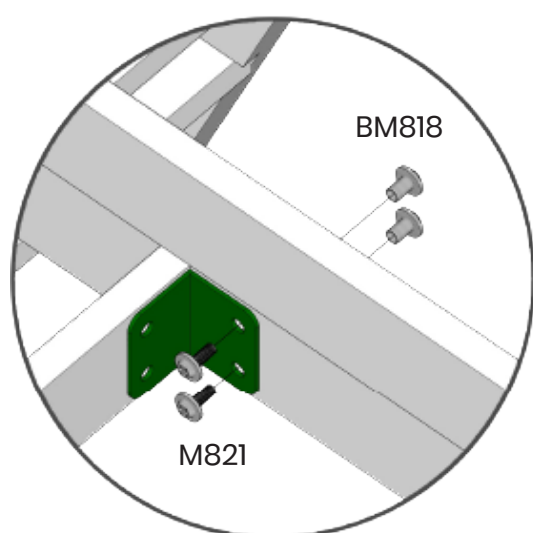
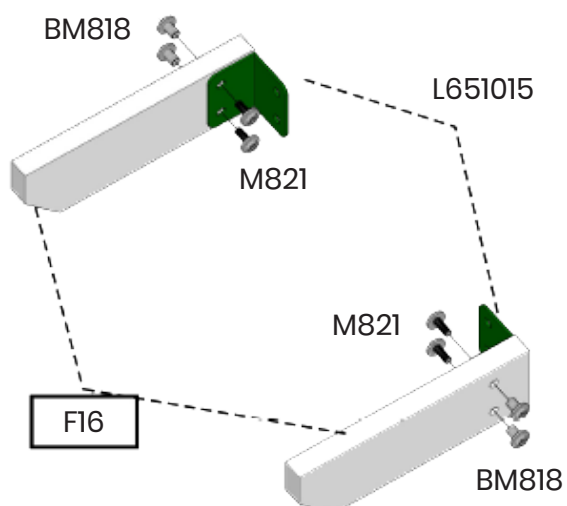

x2

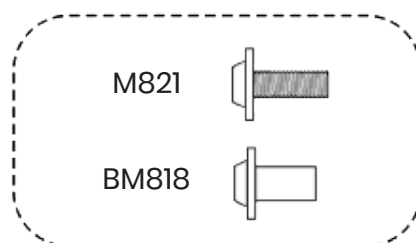
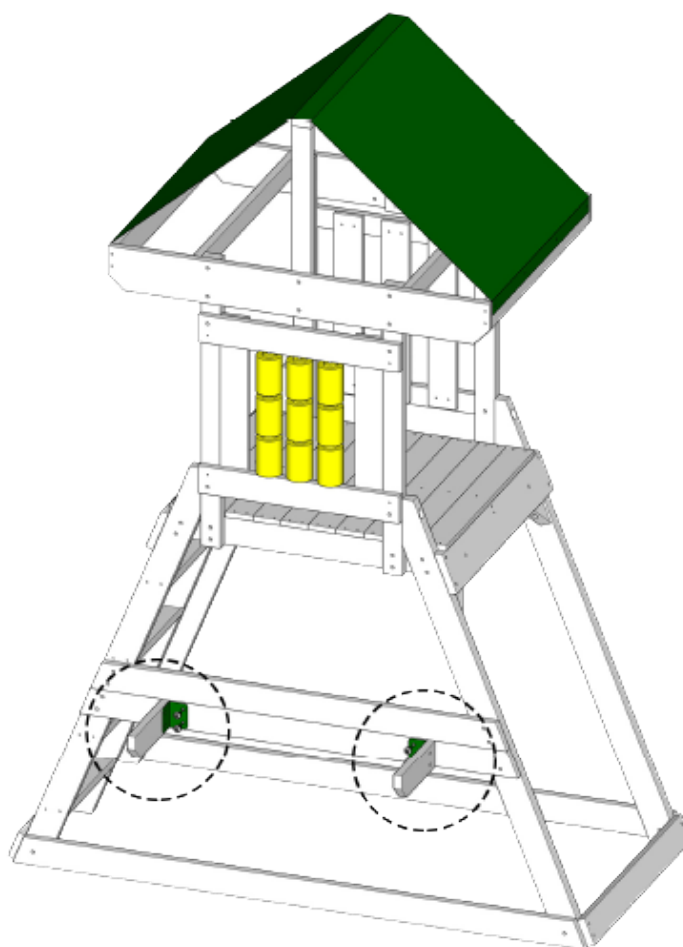

List	
Part No.	Qty.
F16	2
M821	8
BM818	8
L651015	2

STEP 23

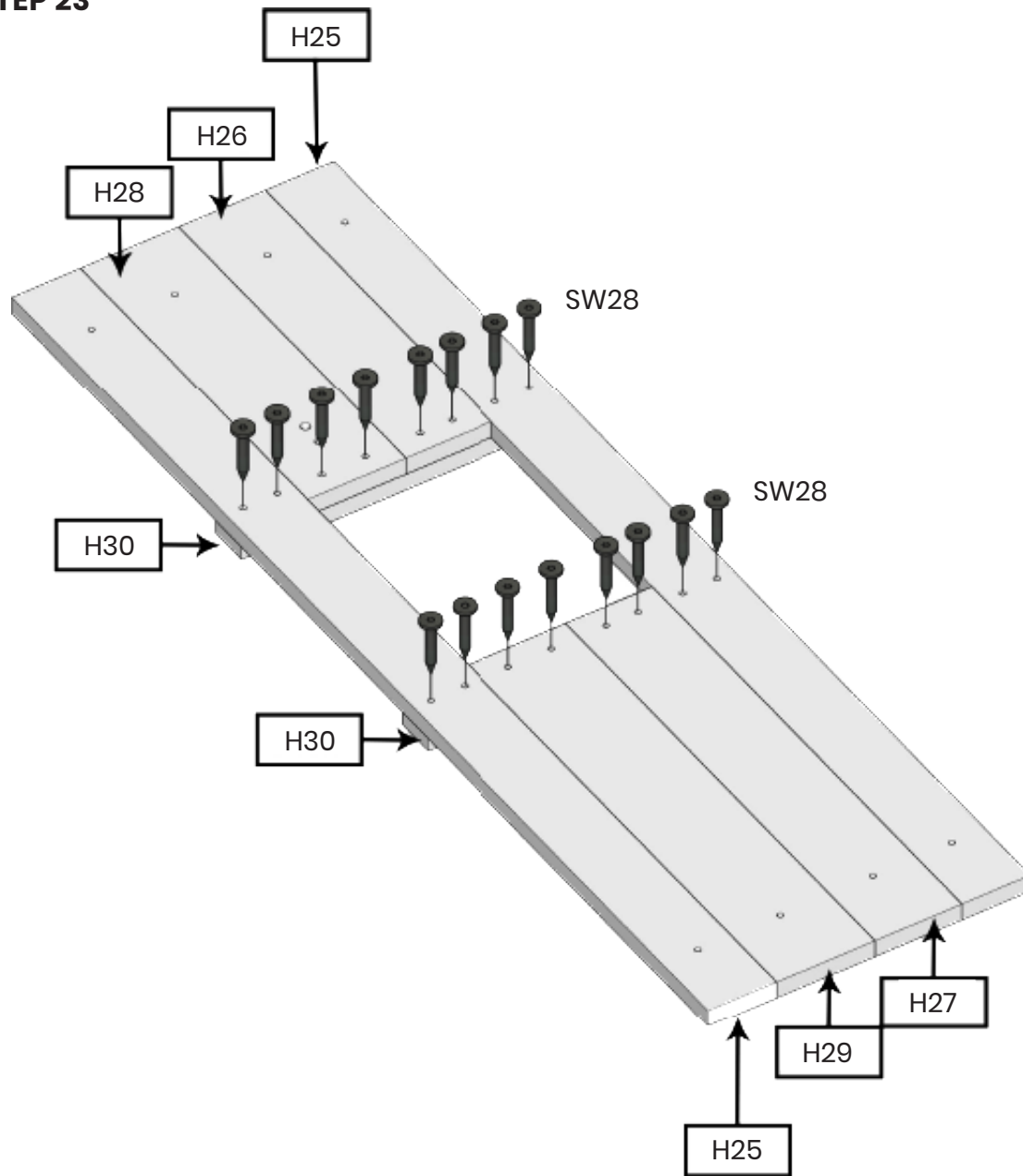

List	
Part No.	Qty.
H25	2
H26	1
H27	1
H28	1
H29	1
H30	2
SW28	16

STEP 24

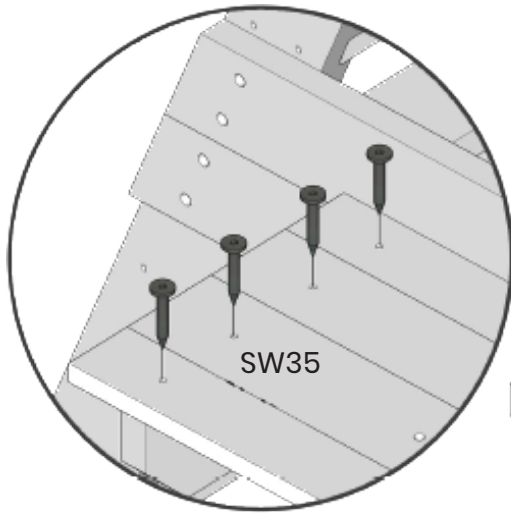

x2

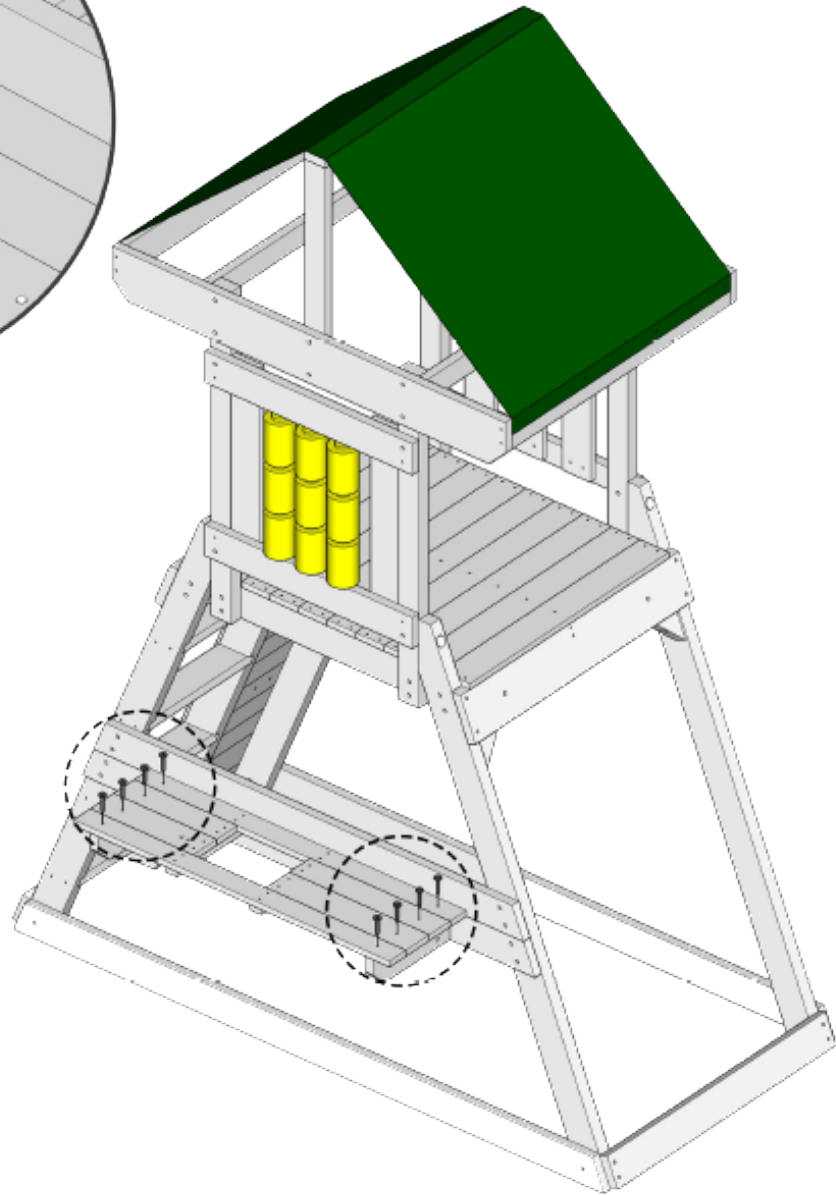

List	
Part No.	Qty.
SW35	8

STEP 25

139008

139007

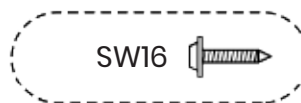
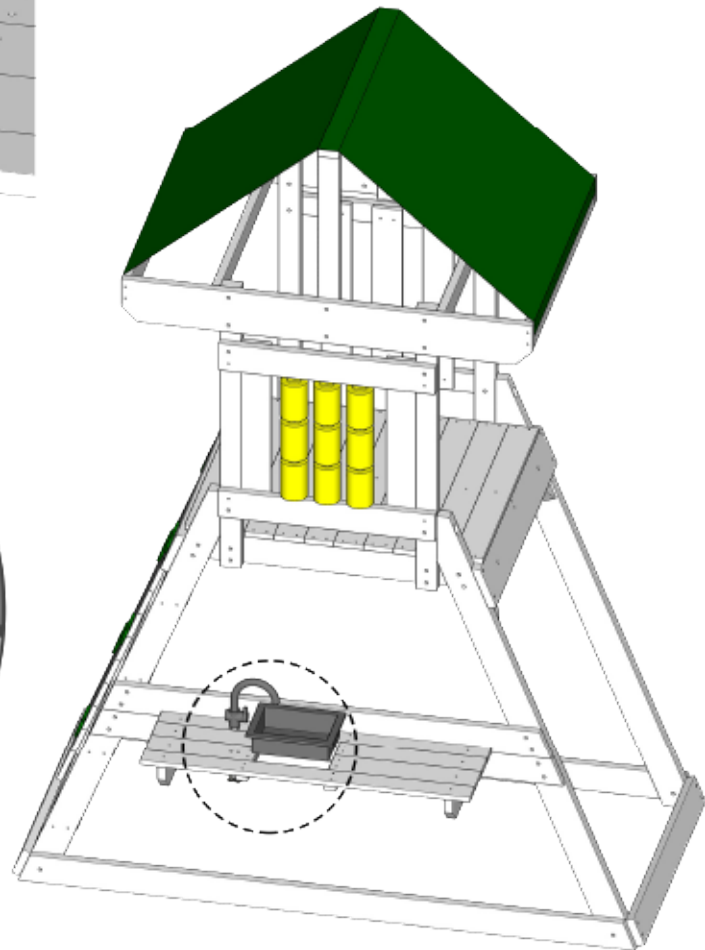
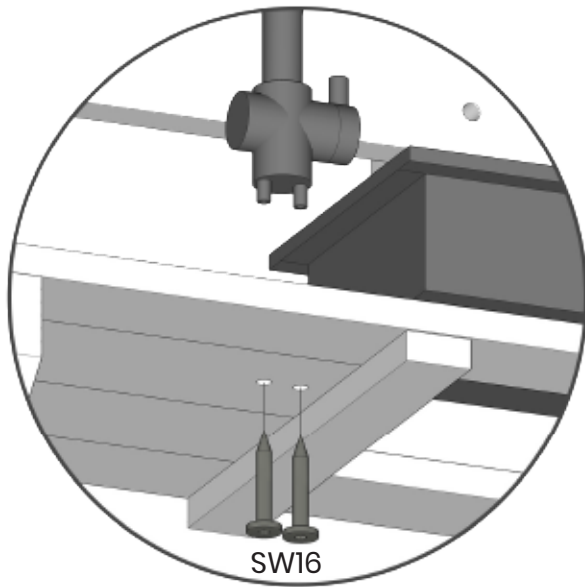
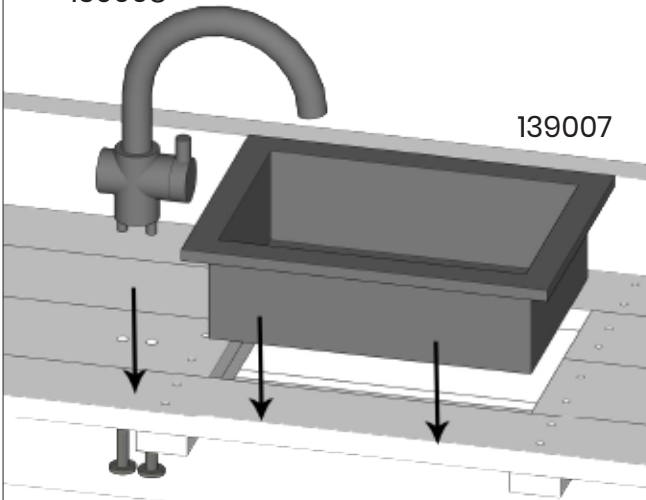

List	
Part No.	Qty.
SW16	2
139008	1
139007	1

STEP 26

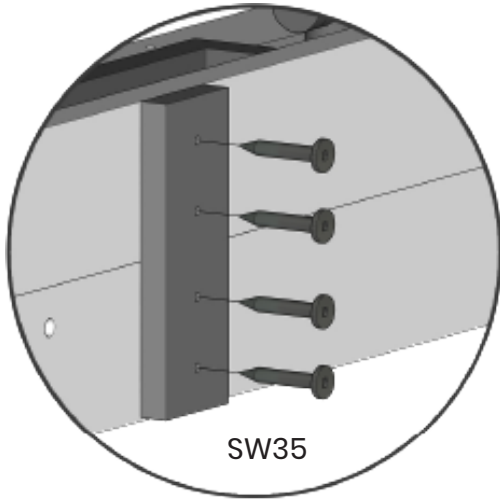

SW35

x2

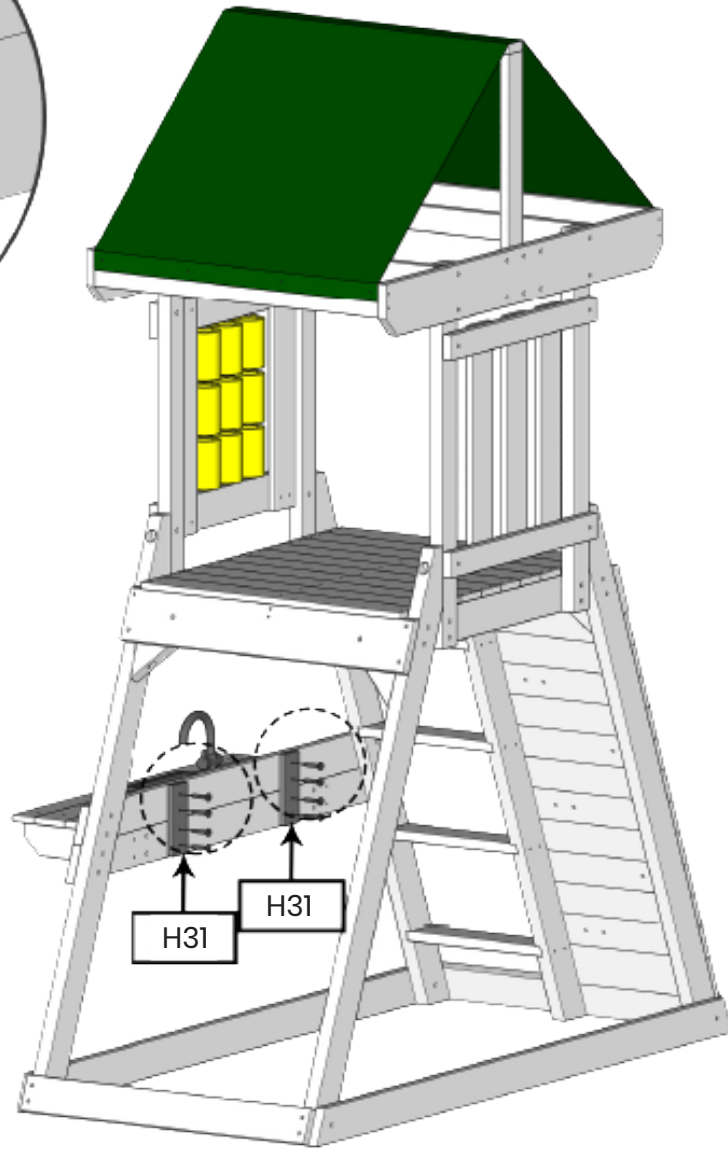

List	
Part No.	Qty.
H31	2
SW35	8

STEP 27

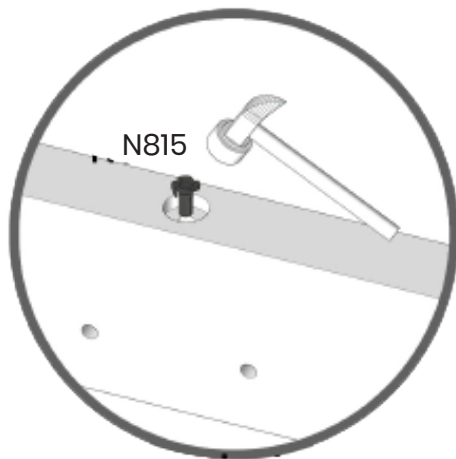
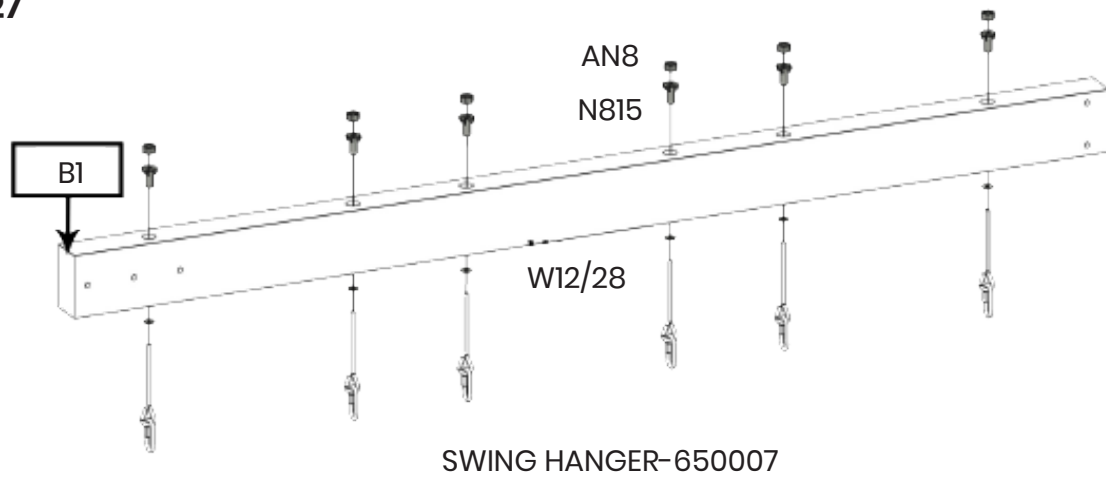

Insert the N815 into the beam by hammer

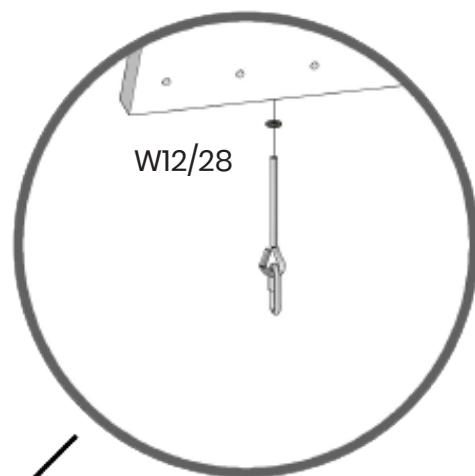

Insert the swing hanger into the beam and fix them with nuts N815 as tightly as possible

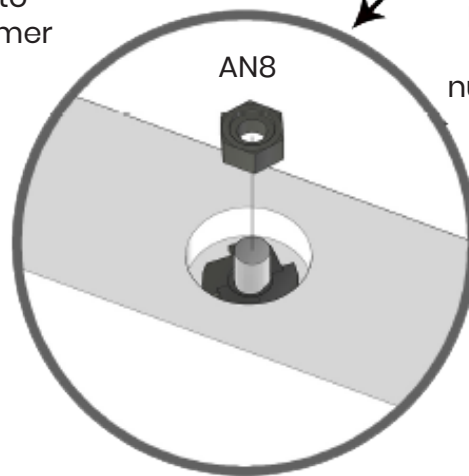

Fix the AN8 as tightly as possible

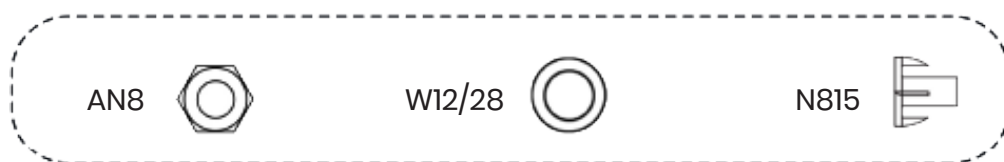

List	
Part No.	Qty.
B1	1
650007	6
AN8	6
W12/28	6
N815	6

STEP 28

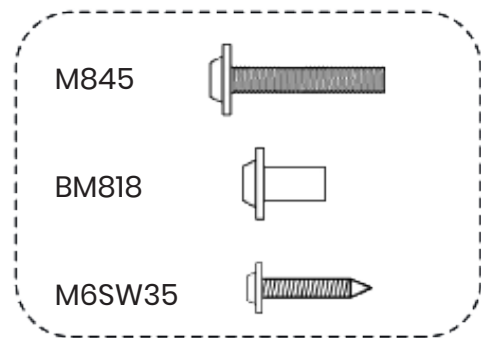
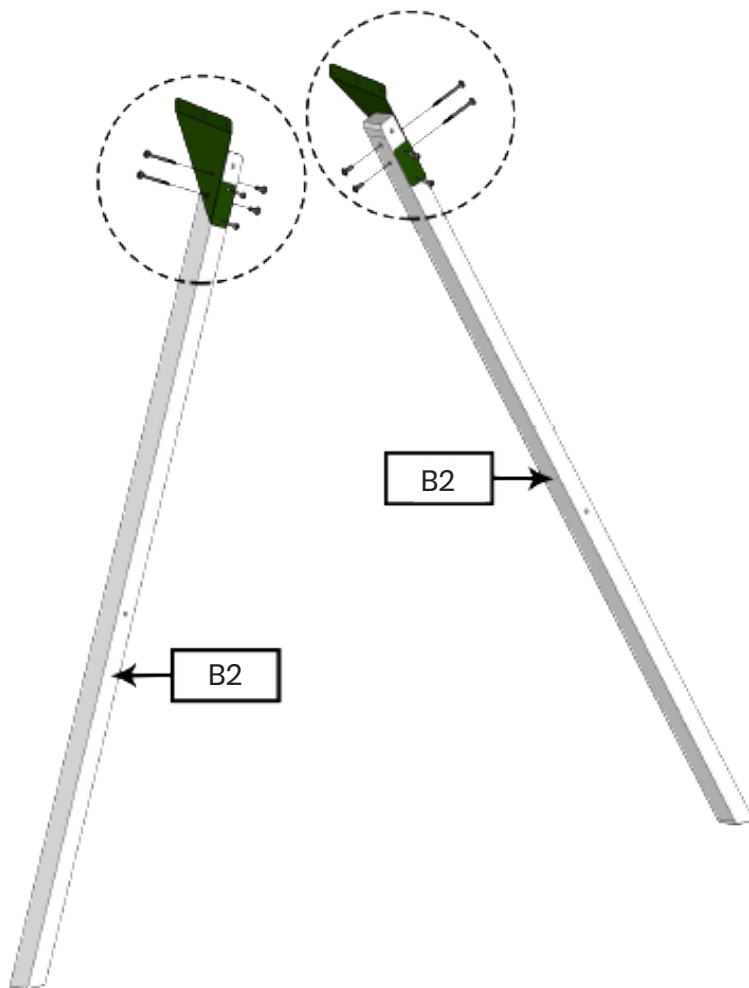
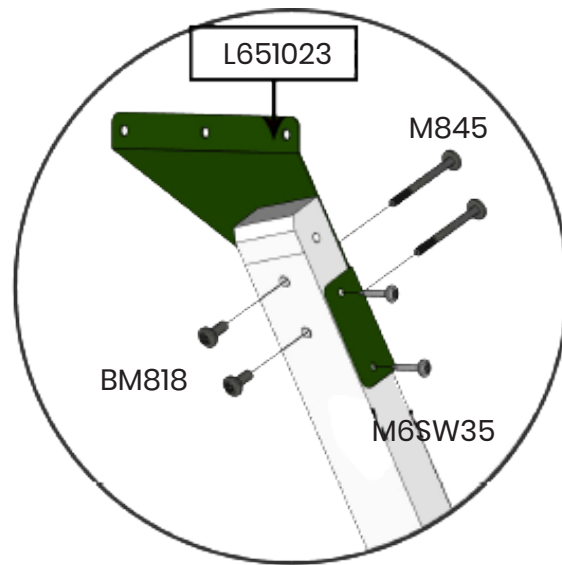
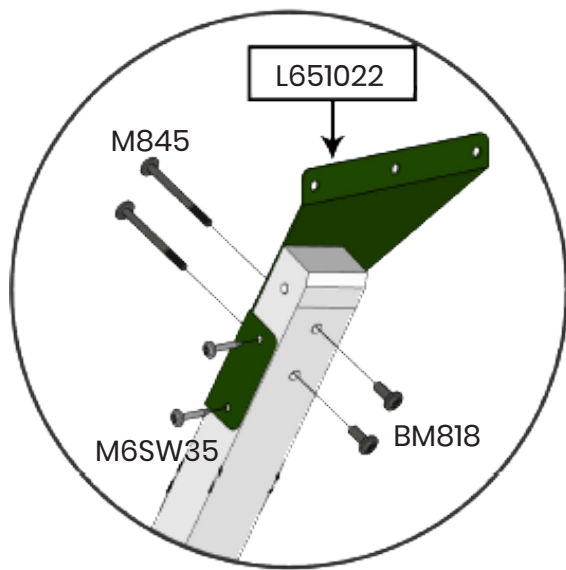

List	
Part No.	Qty.
B2	2
M845	4
BM818	4
M6SW35	4
L651022	1
L651023	1

STEP 29

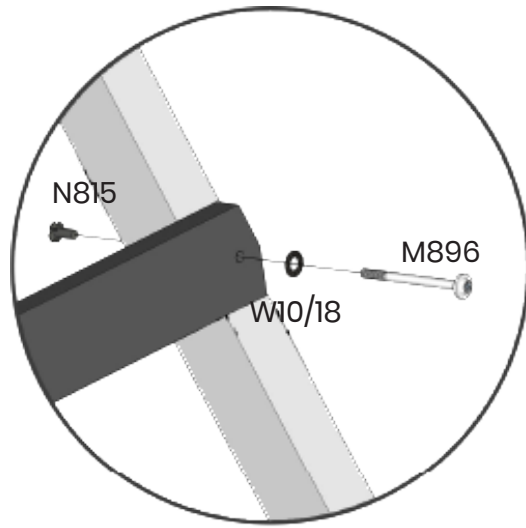

x2

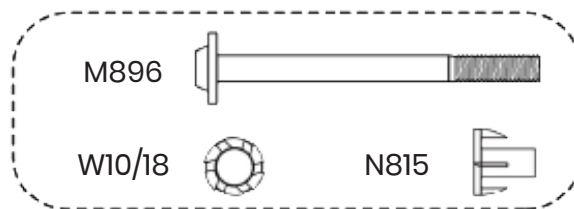
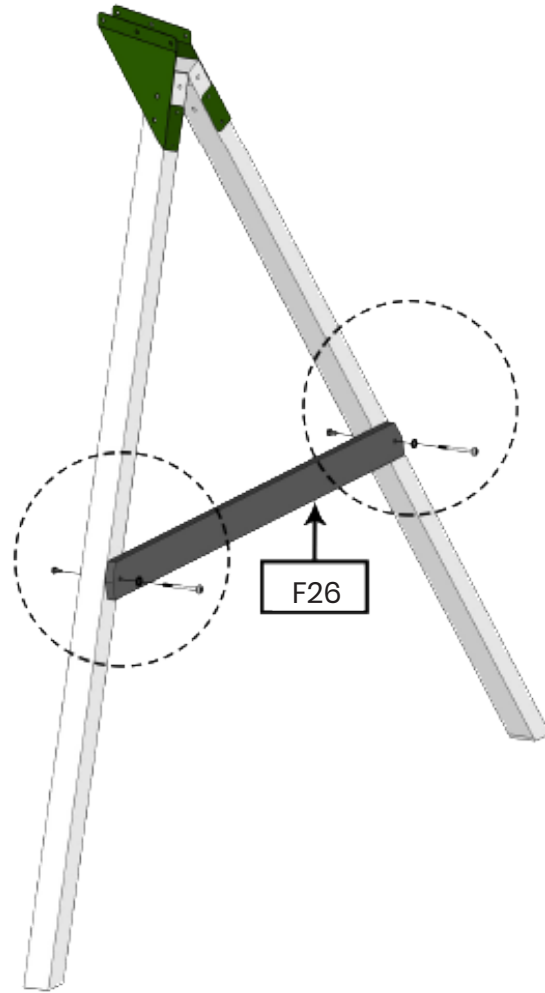

List	
Part No.	Qty.
F26	1
M896	2
N815	2
W10/18	2

STEP 30

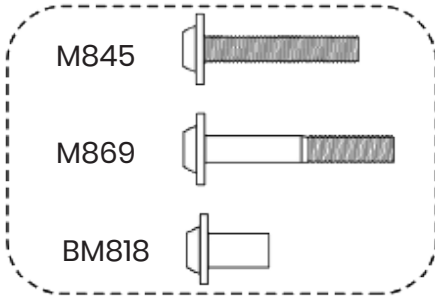
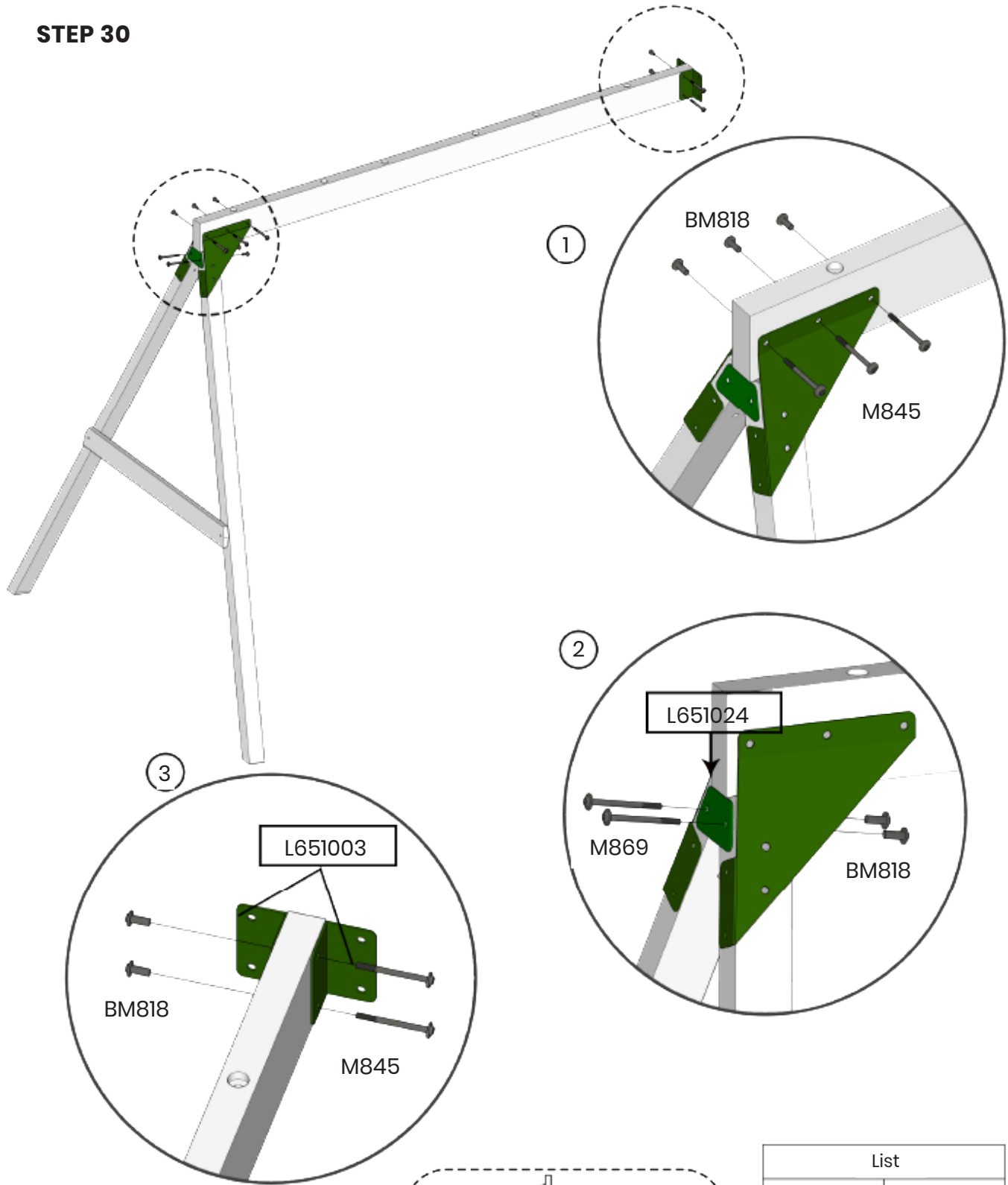

List	
Part No.	Qty.
M845	5
M869	2
BM818	7
L651024	1
L651003	2

STEP 31

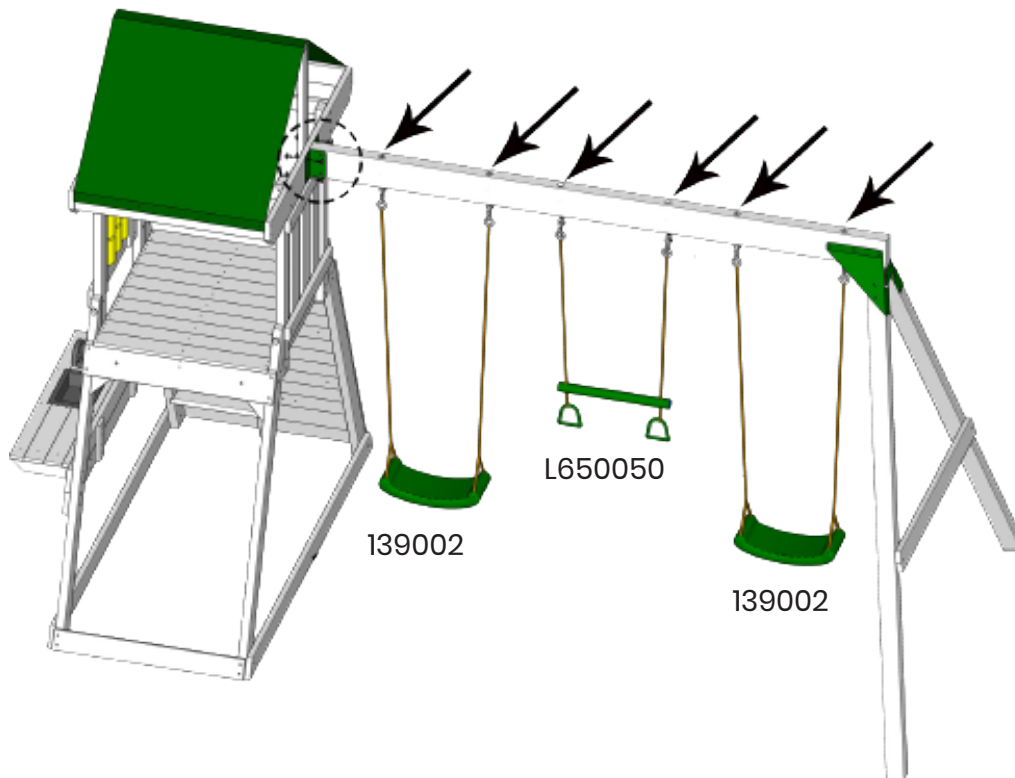
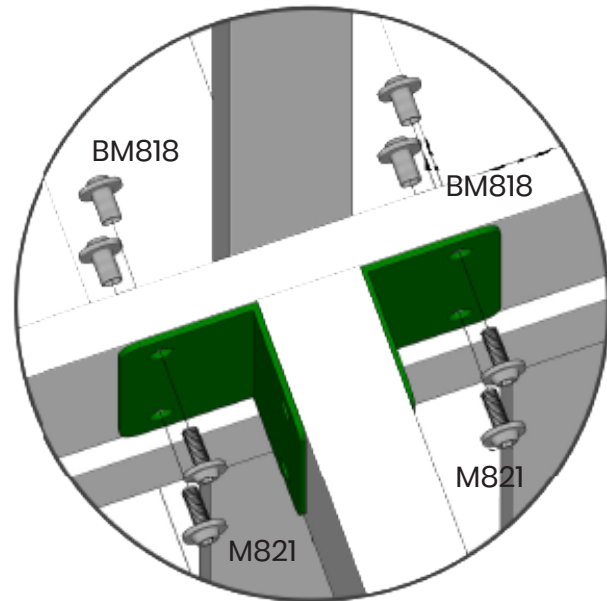

Hang the swing



List	
Part No.	Qty.
M821	4
BM818	4
139002	2
L650050	1

STEP 32

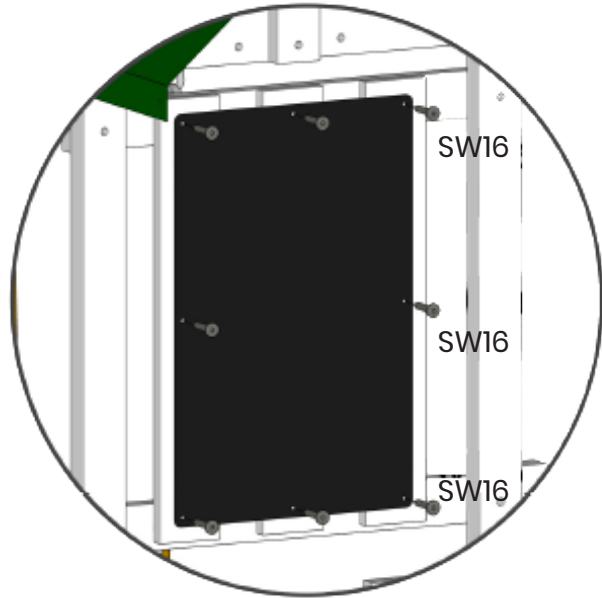

148001

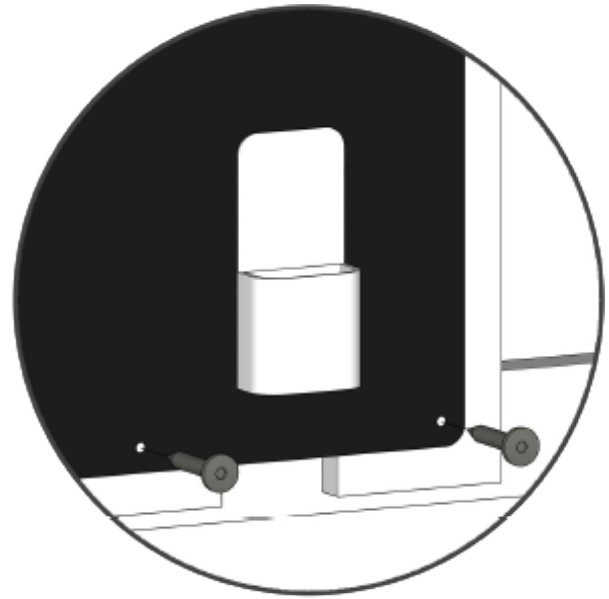

FBH-1

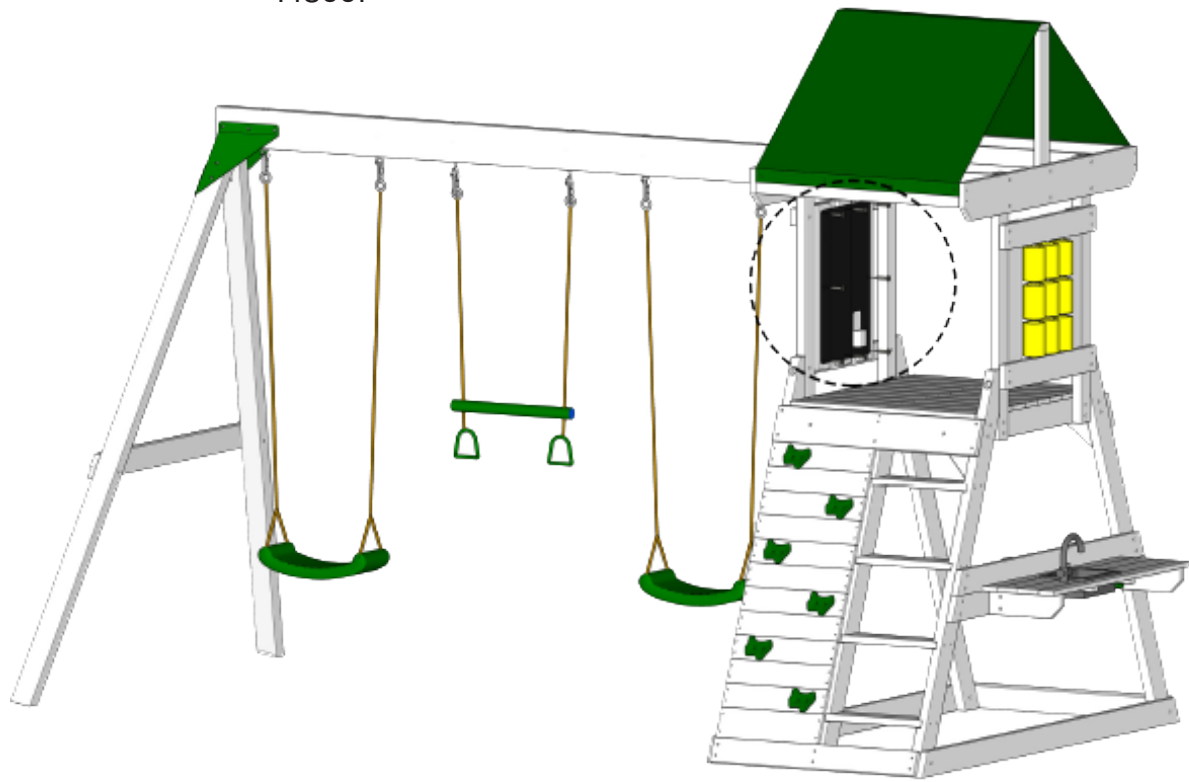

List	
Part No.	Qty.
SW16	8
148001	1
FBH-1	1

STEP 33

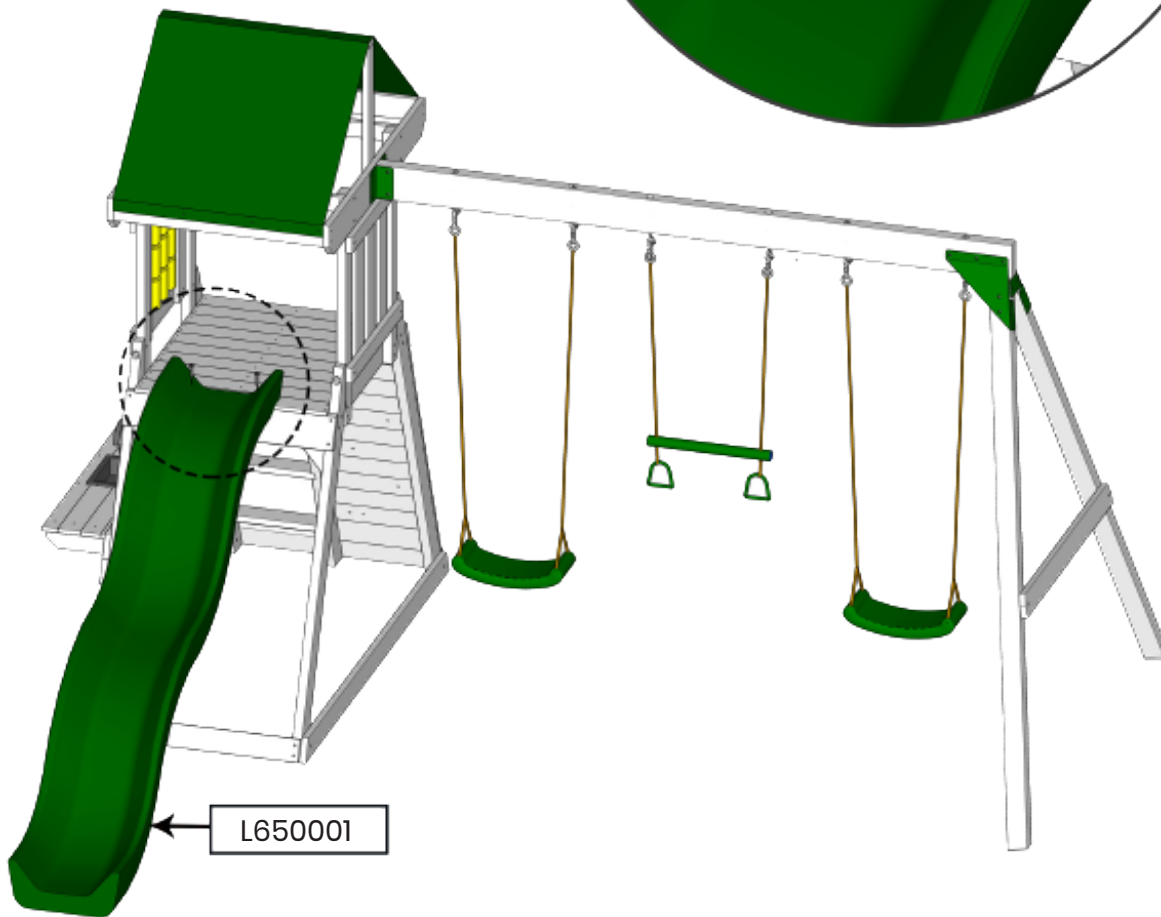
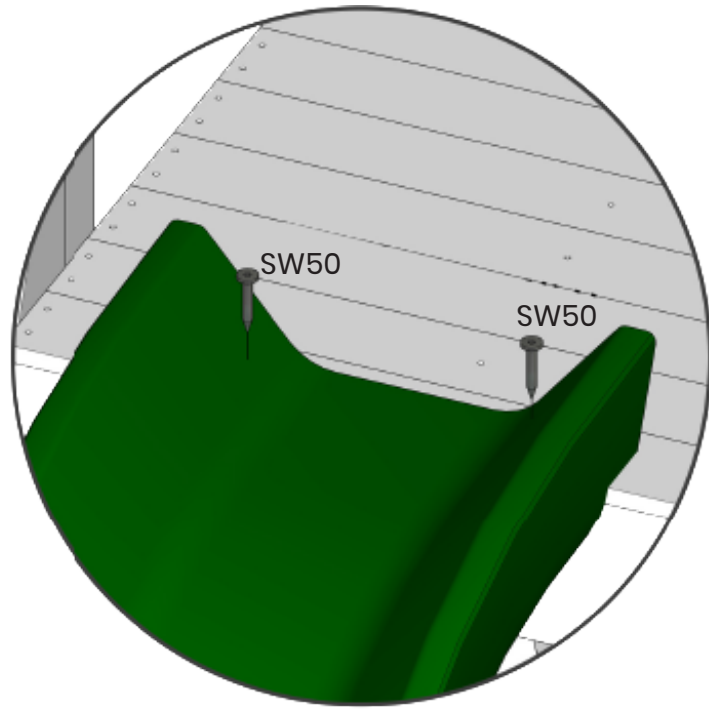

List	
Part No.	Qty.
SW50	2
L650001	1

STEP 34

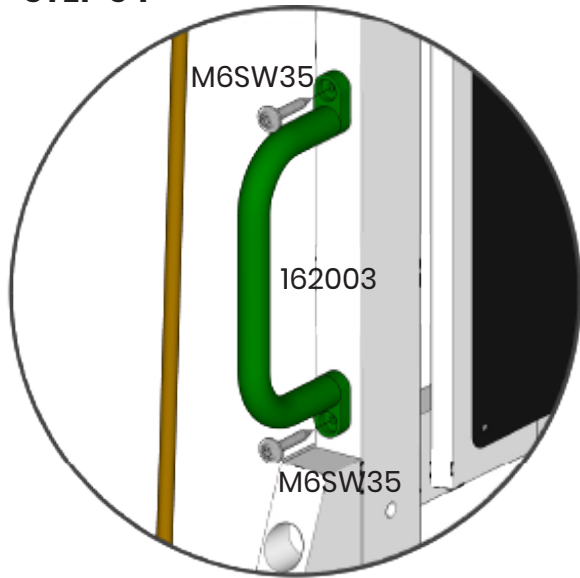

x2

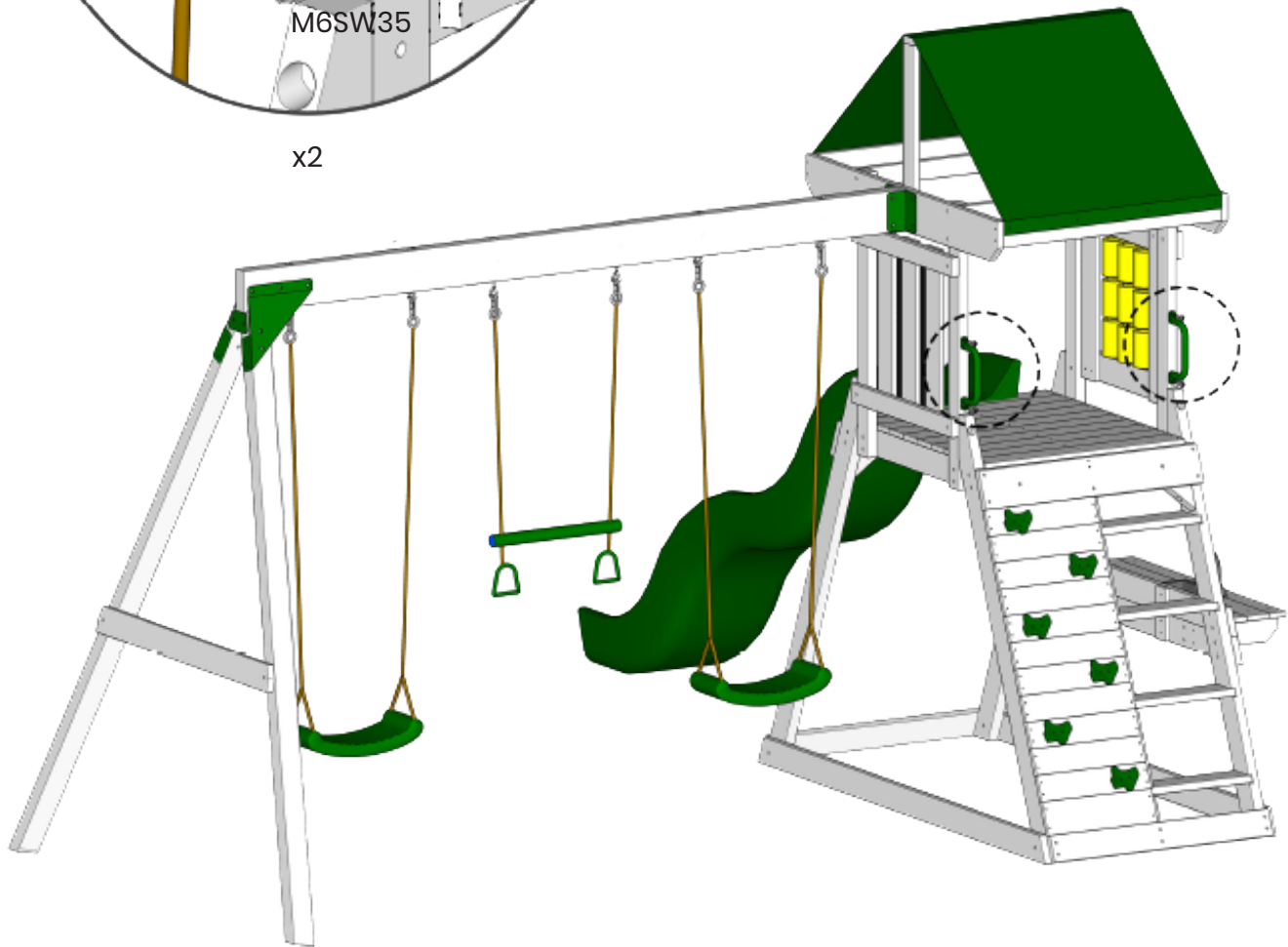

List	
Part No.	Qty.
M6SW35	4
162003	2

STEP 35

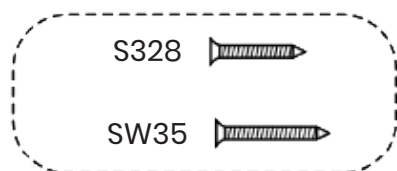
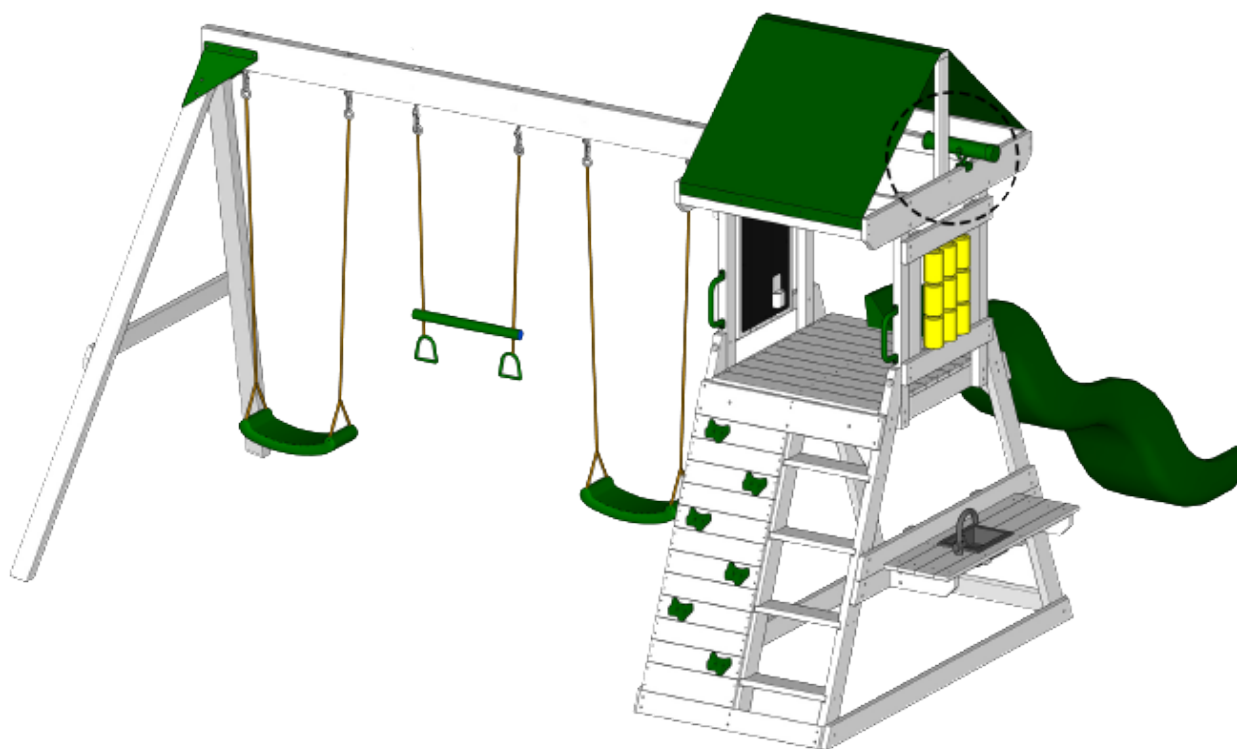
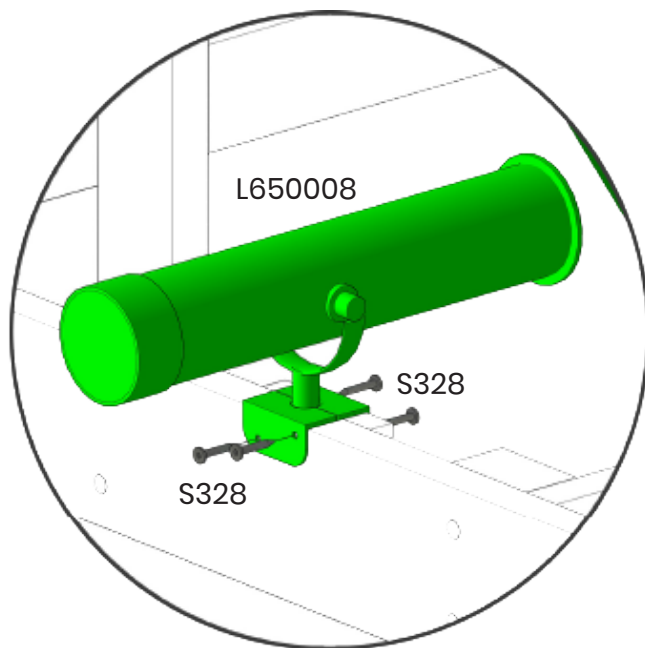
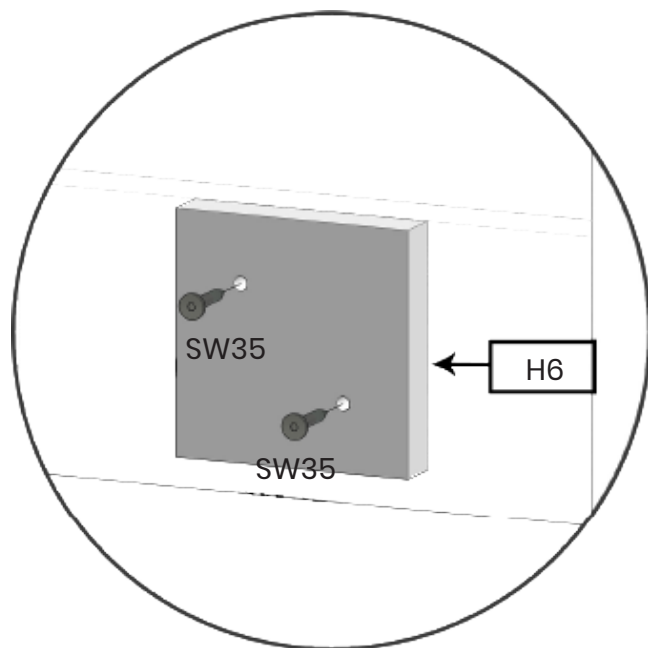

List	
Part No.	Qty.
H6	1
SW35	2
S328	4
L650008	1

STEP 36

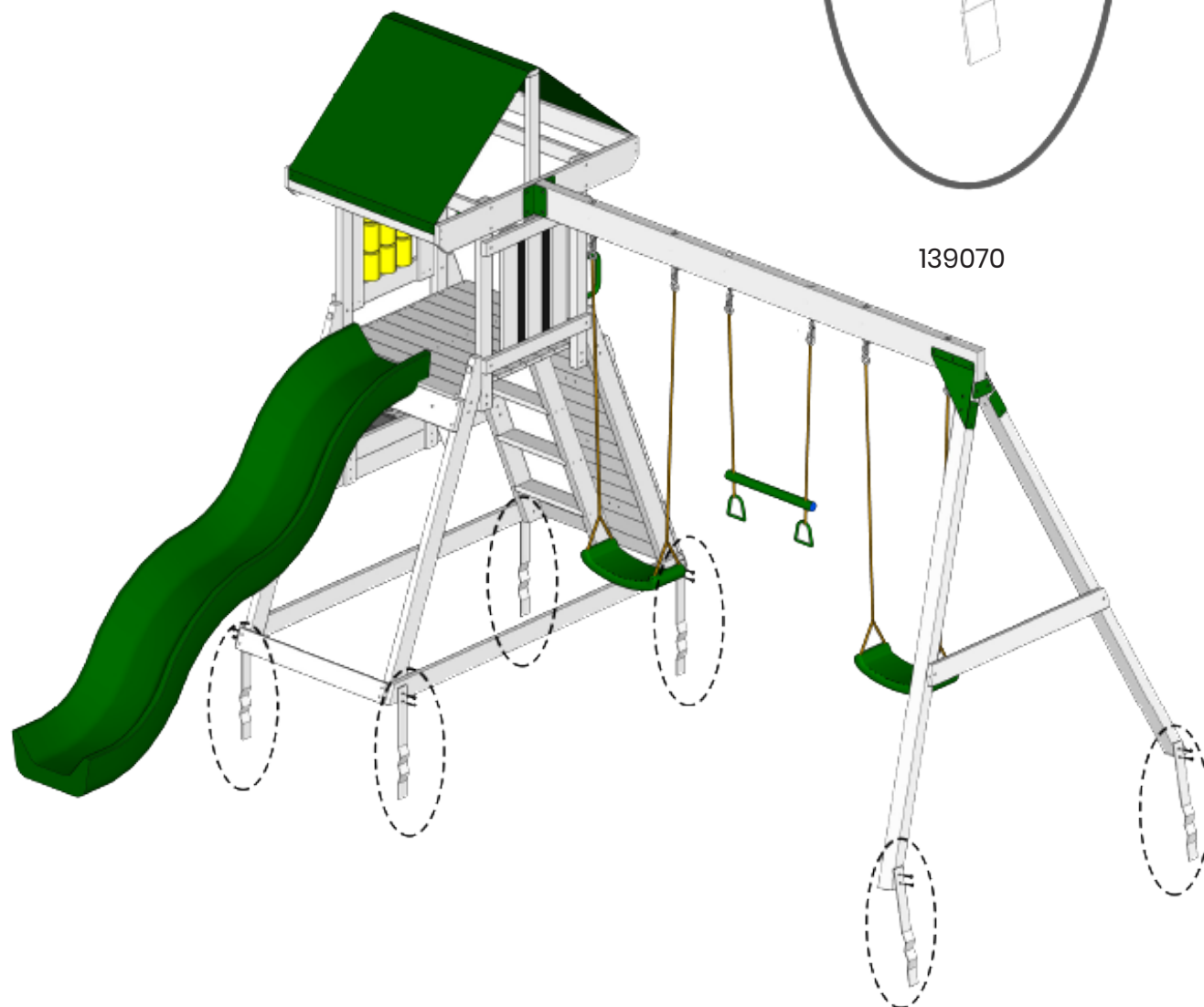
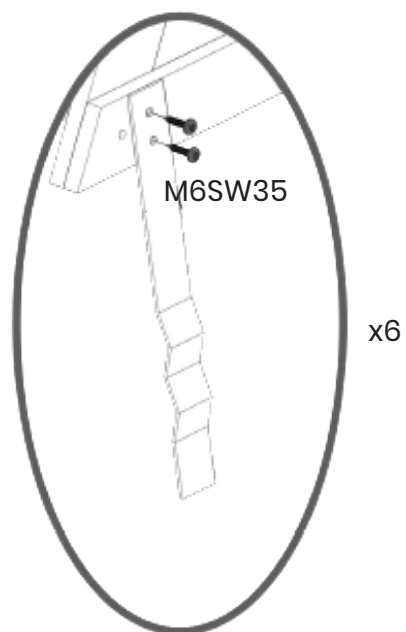

List	
Part No.	Qty.
M6SW35	12
139070	6

STEP 37

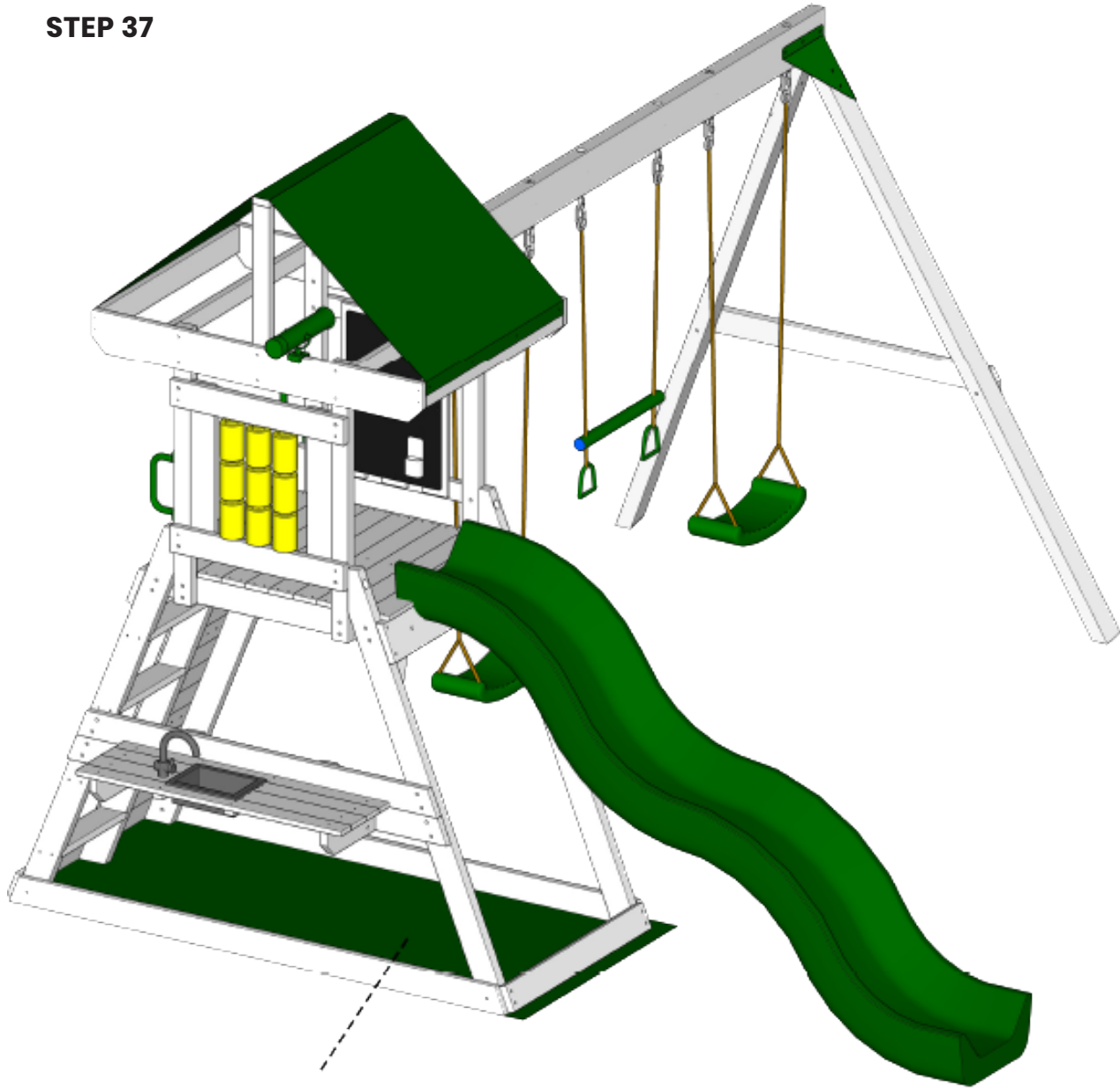

162033
Put on a base cloth

List	
Part No.	Qty.
162033	1

STEP 38

Tie the rope tightly

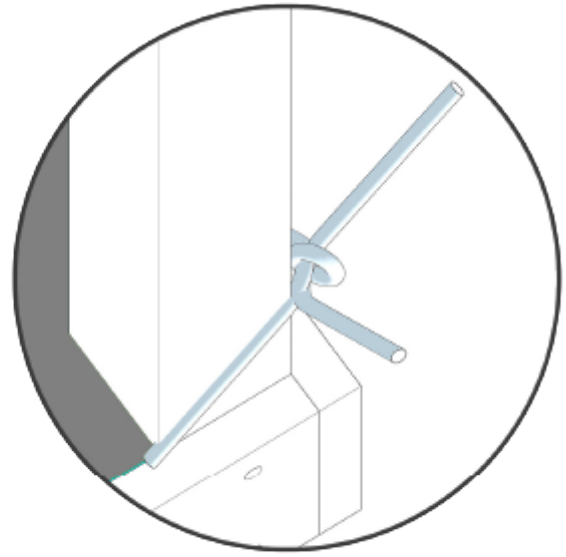

x5

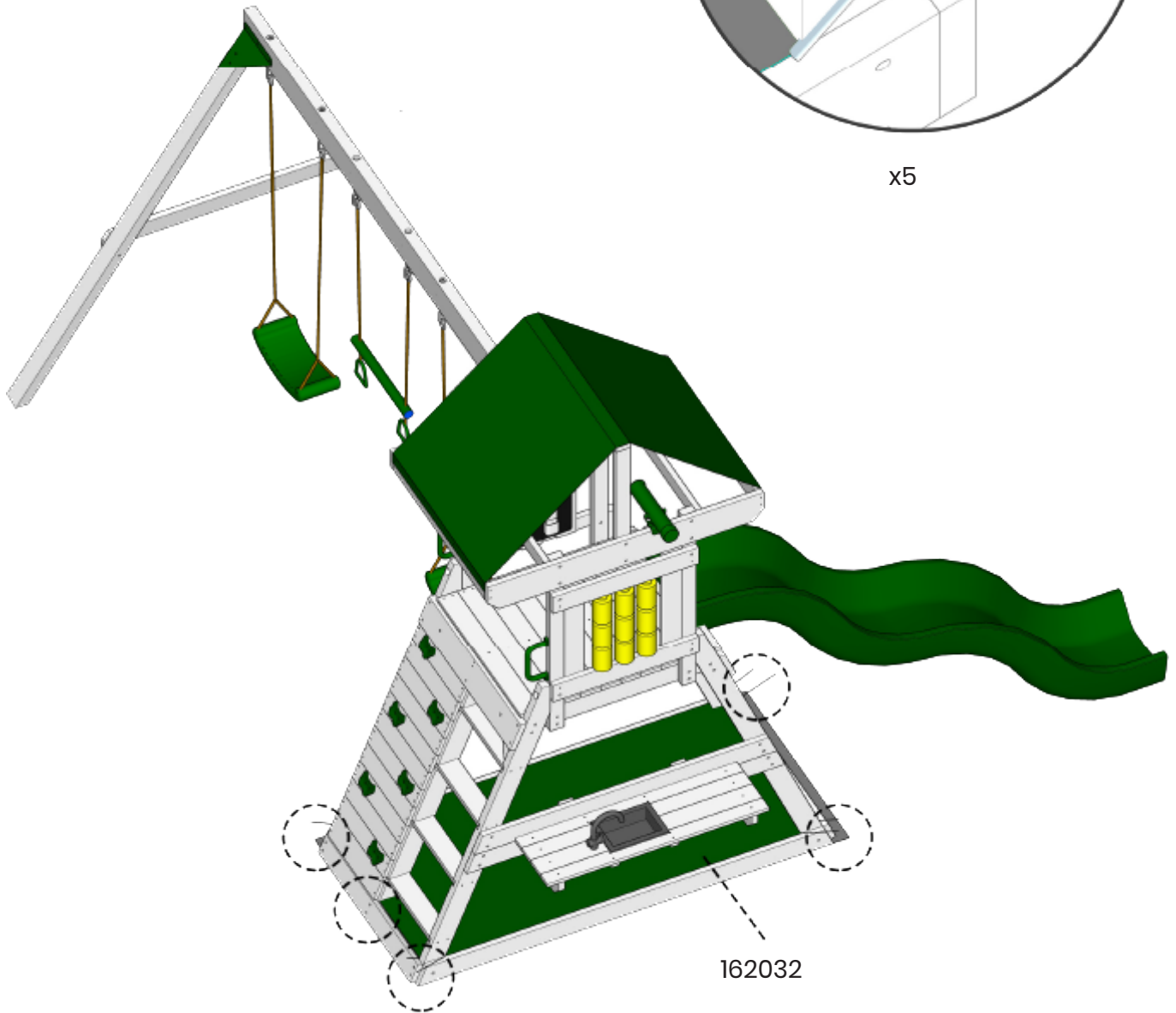

162032

List	
Part No.	Qty.
162032	1

STEP 39

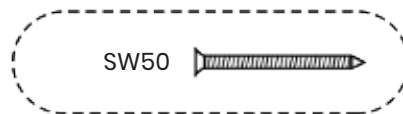
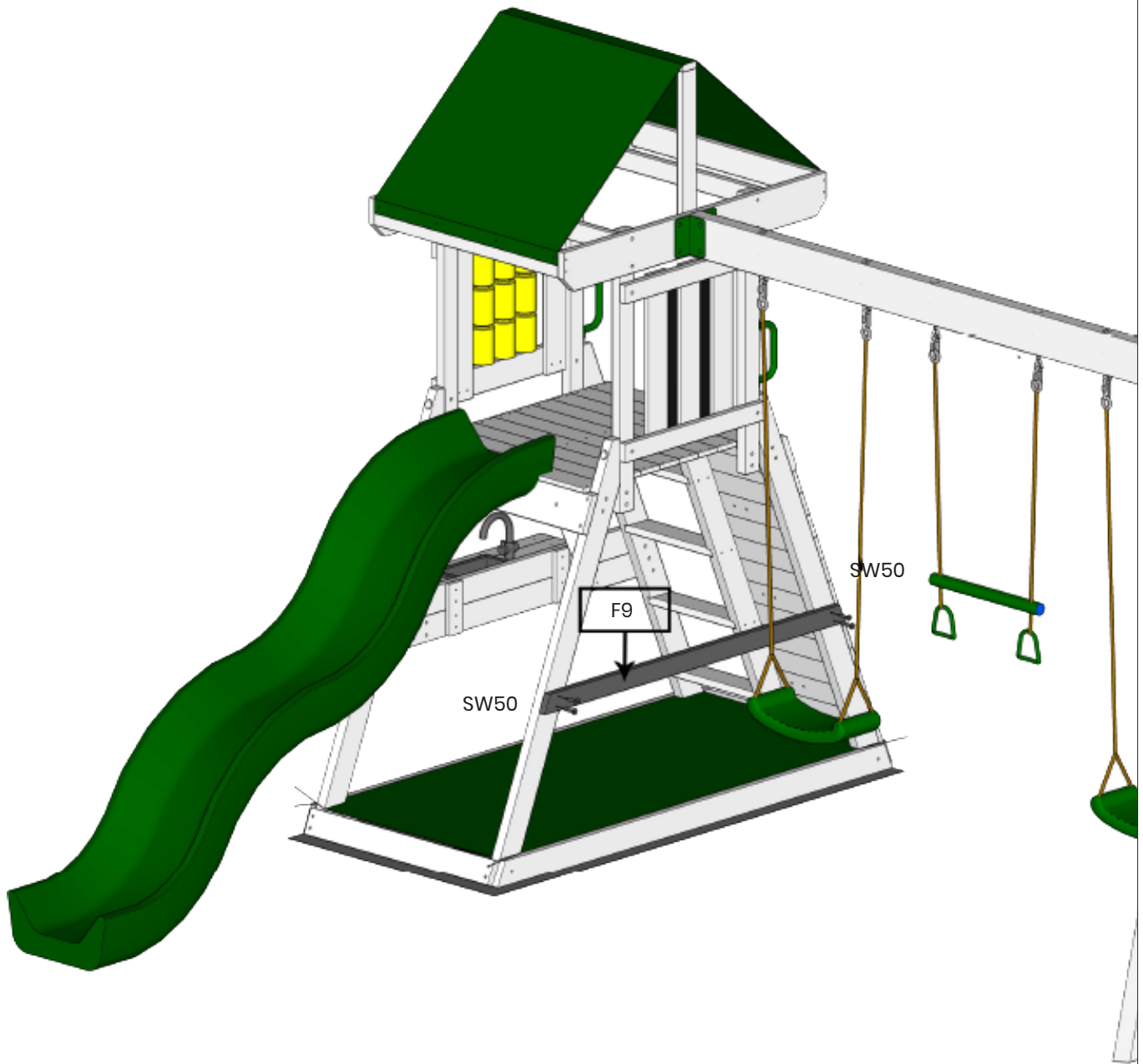

List	
Part No.	Qty.
F9	1
SW50	4